



US00D629198S

(12) **United States Design Patent**
Fox et al.

(10) **Patent No.:** **US D629,198 S**

(45) **Date of Patent:** **** Dec. 21, 2010**

(54) **LUGGAGE**

(75) Inventors: **Kevin Fox**, Glasgow (GB); **Lawrence Broadley**, Glasgow (GB)

(73) Assignee: **Latitude 56 Degrees Ltd.**, Glasgow (GB)

(**) Term: **14 Years**

(21) Appl. No.: **29/344,653**

(22) Filed: **Oct. 1, 2009**

(51) **LOC (9) Cl.** **03-01**

(52) **U.S. Cl.** **D3/273**

(58) **Field of Classification Search** D3/201,
D3/205, 232, 233, 245, 247, 269, 273, 274,
D3/278, 292, 294, 295, 303, 318, 321, 323,
D3/901, 905; D28/83; 190/121; 206/349,
206/373; 220/674, 675, 676

See application file for complete search history.

(56) **References Cited**

U.S. PATENT DOCUMENTS

D31,901 S * 11/1899 Deem D3/299
D126,220 S * 4/1941 Goldsmith D3/245
D129,190 S * 8/1941 Pichel D3/245
D479,401 S * 9/2003 Claypool D3/294
D499,548 S * 12/2004 Deutschendorf et al. D3/278
D613,945 S * 4/2010 Molina D3/294

FOREIGN PATENT DOCUMENTS

GB 4010174 * 2/2009

OTHER PUBLICATIONS

The Rat-Pack compact carry-on approved garment chamber by Latitude 56°, as shown in the article, "Seen@The Show," from May 2010

Travel Goods Showcase (www.travel-goods.org), (20 pages, refer to the 12th page, which is page No. 41). Travel goods show occurred Mar. 2-4, 2010 in Las Vegas, Nevada.*

Rat-Pak carry-on, as seen on www.lat56.com, viewed Jul. 2, 2010 (4 pages).*

* cited by examiner

Primary Examiner—Elizabeth A Albert

Assistant Examiner—Karen E Eldridge Powers

(74) *Attorney, Agent, or Firm*—Dykas & Shaver, LLP

(57) **CLAIM**

The ornamental design for luggage, as shown and described.

DESCRIPTION

FIG. 1 is a perspective view of a first embodiment of the luggage;

FIG. 2 is a first end view of the luggage of FIG. 1;

FIG. 3 is a top side view of the luggage of FIG. 1 and FIG. 8;

FIG. 4 is a second end view of the luggage of FIG. 1;

FIG. 5 is a first side view of the luggage of FIG. 1;

FIG. 6 is a second side view of the luggage of FIG. 1;

FIG. 7 is a bottom side view of the luggage of FIG. 1;

FIG. 8 is a perspective view of a second embodiment of the luggage of FIGS. 1-7;

FIG. 9 is a first end view of the luggage of FIG. 8;

FIG. 10 is a second end view of the luggage of FIG. 8;

FIG. 11 is bottom side view of the luggage of FIG. 8;

FIG. 12 is a first side view of the luggage of FIG. 8; and,

FIG. 13 is a second side view of the luggage of FIG. 8.

1 Claim, 6 Drawing Sheets

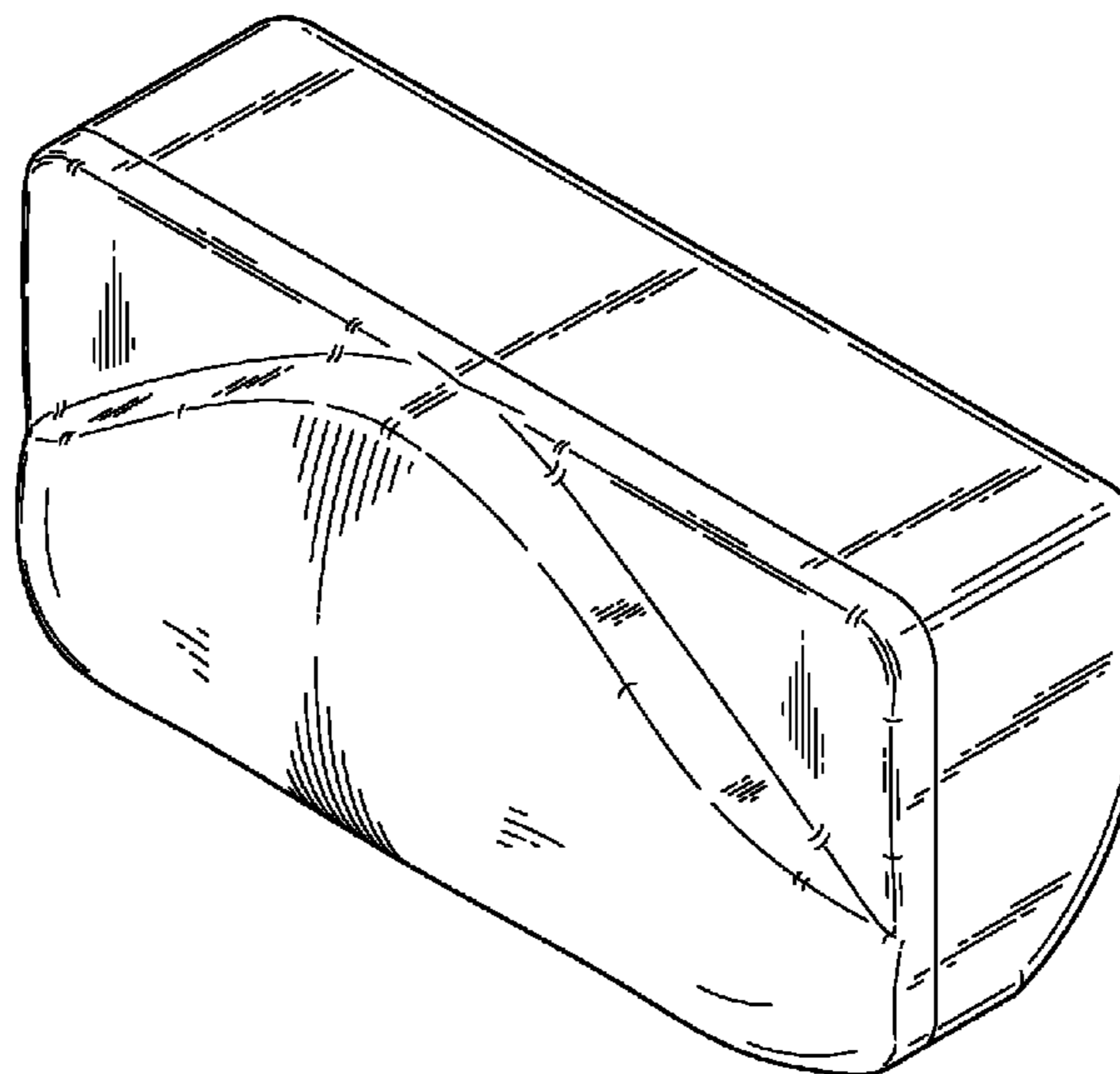
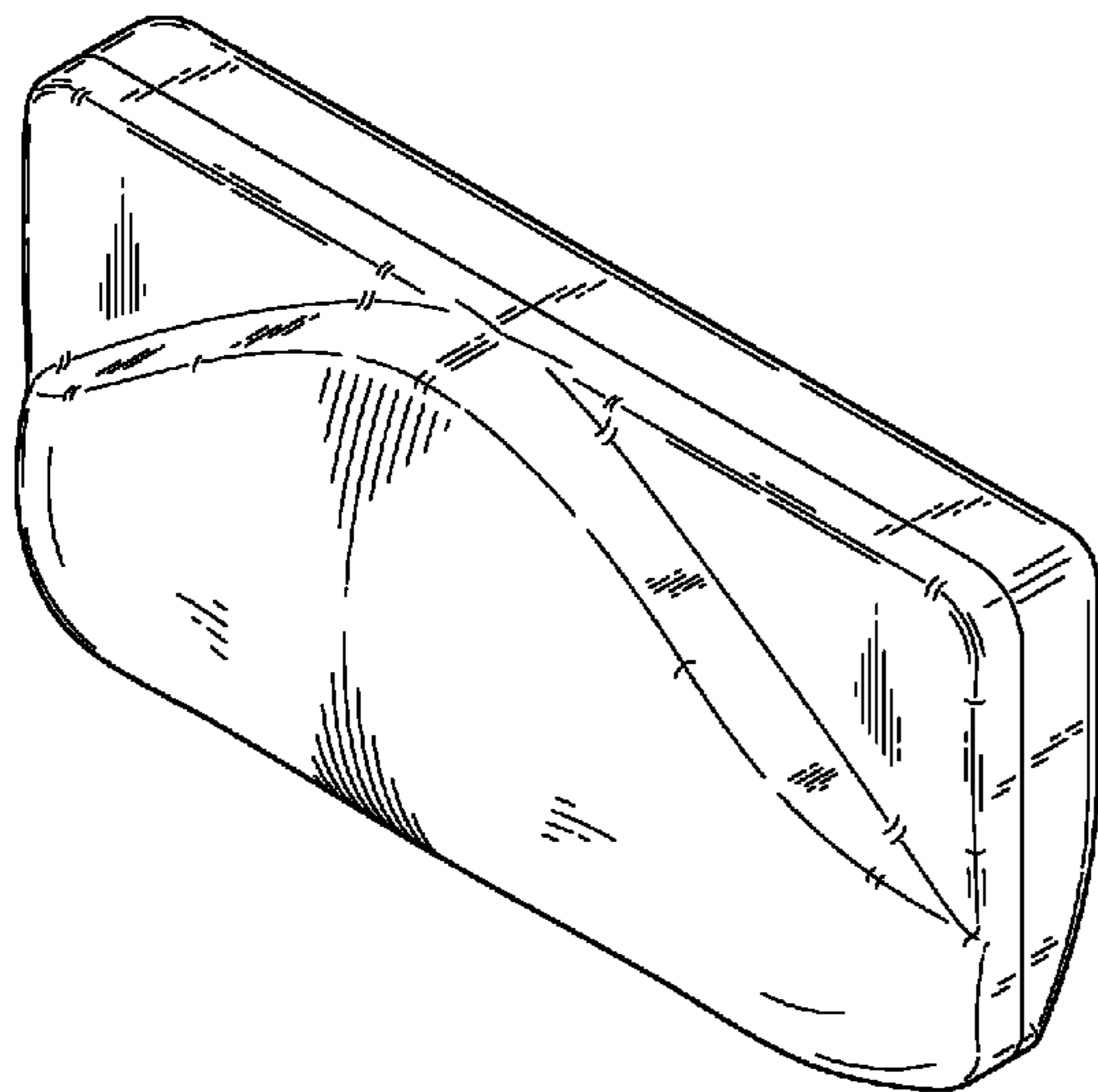

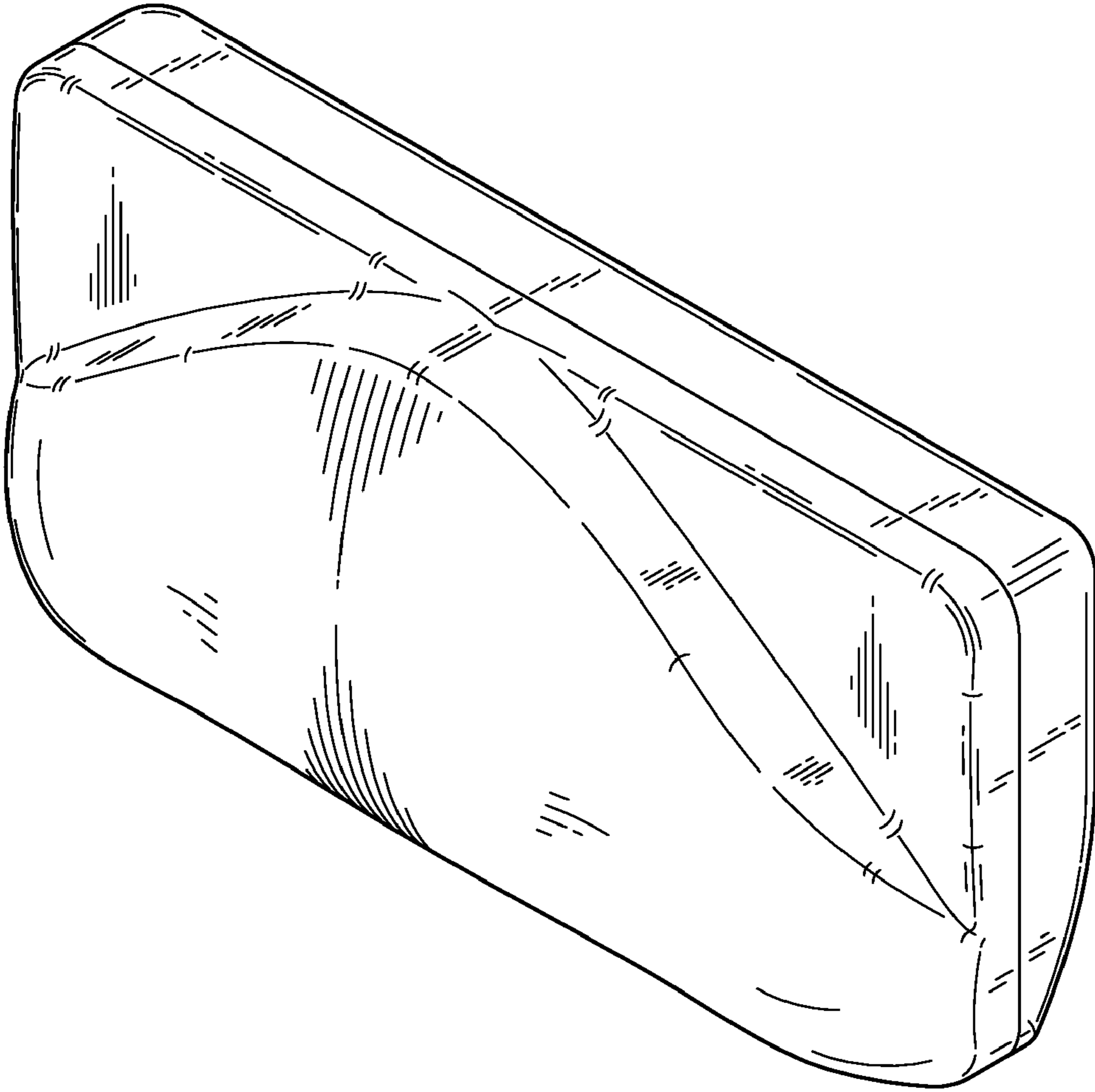

FIG. 1

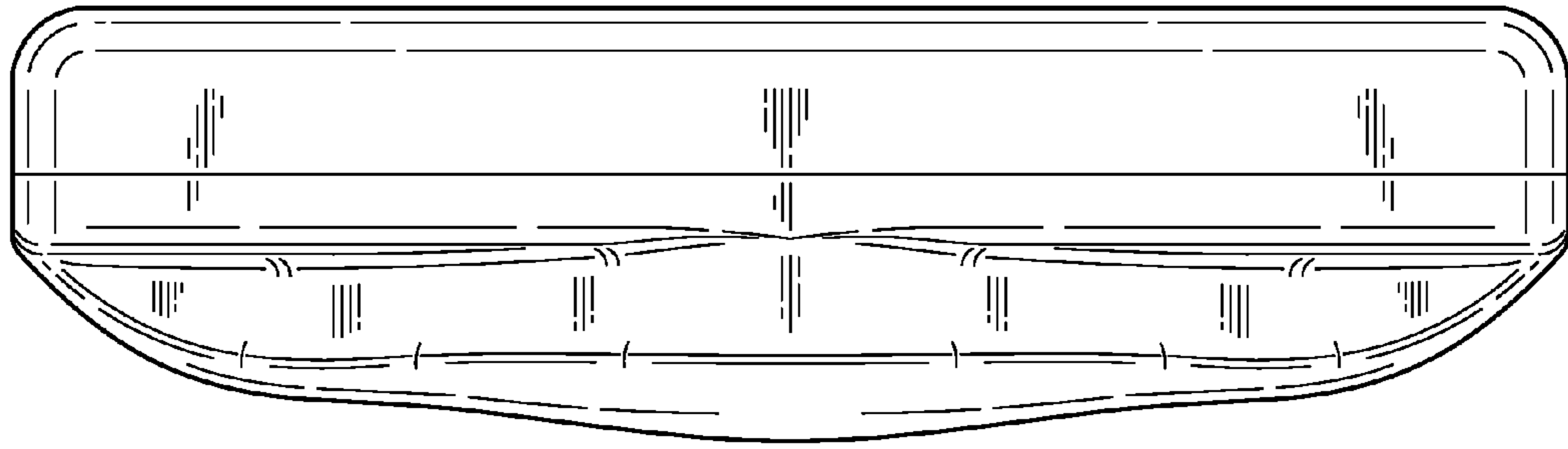

FIG. 2

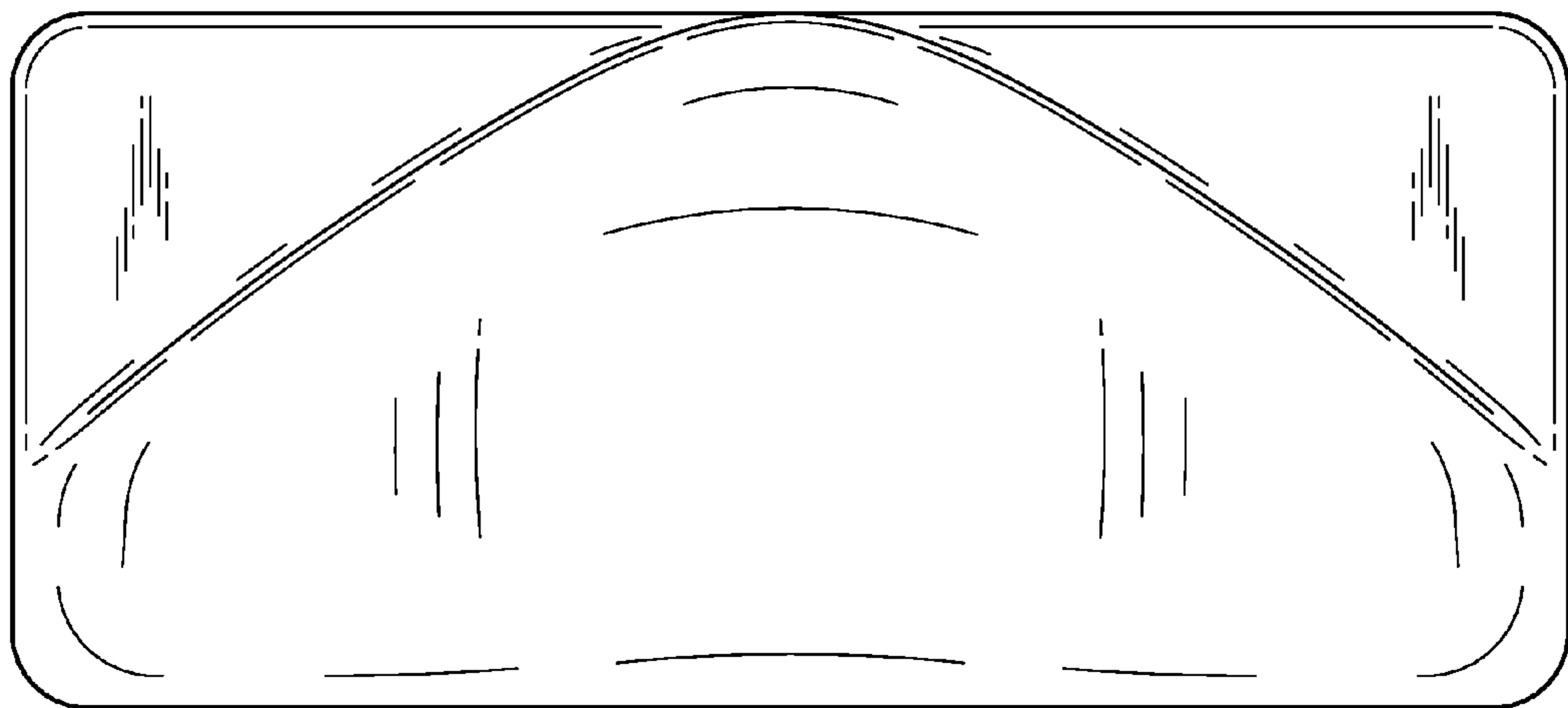

FIG. 3

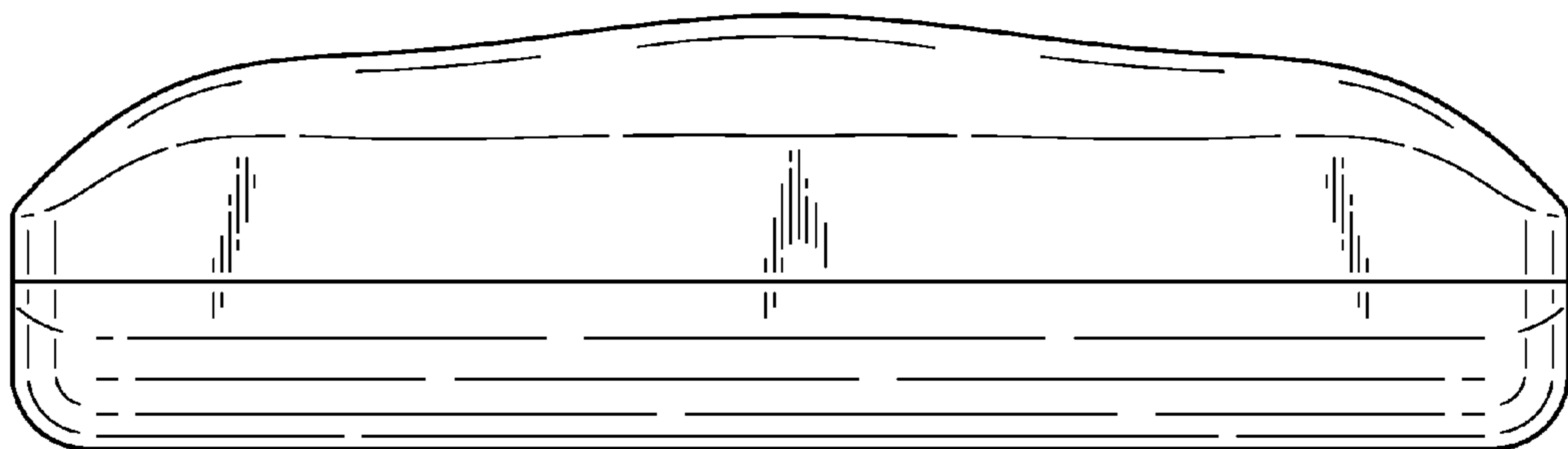

FIG. 4

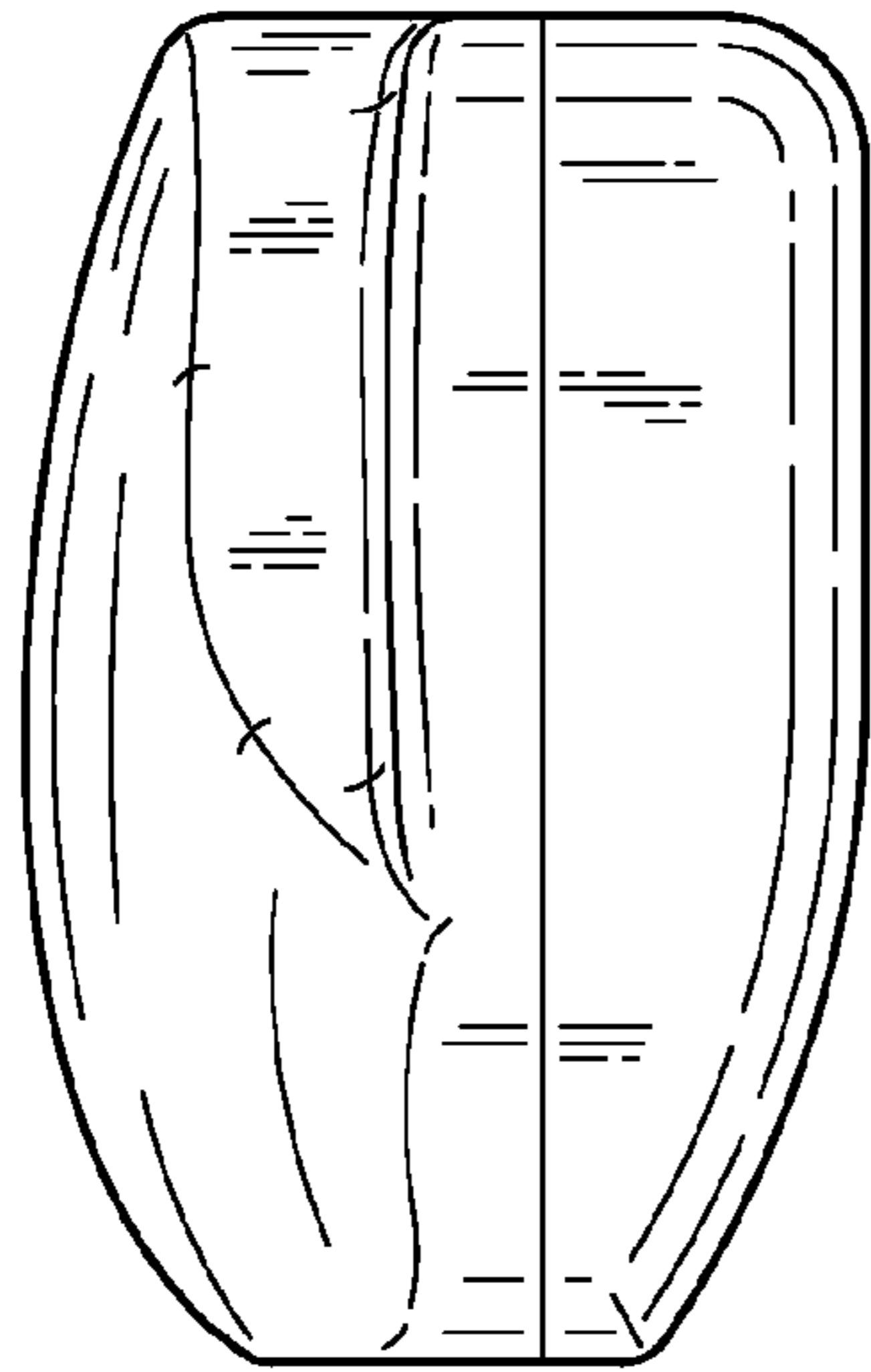

FIG. 5

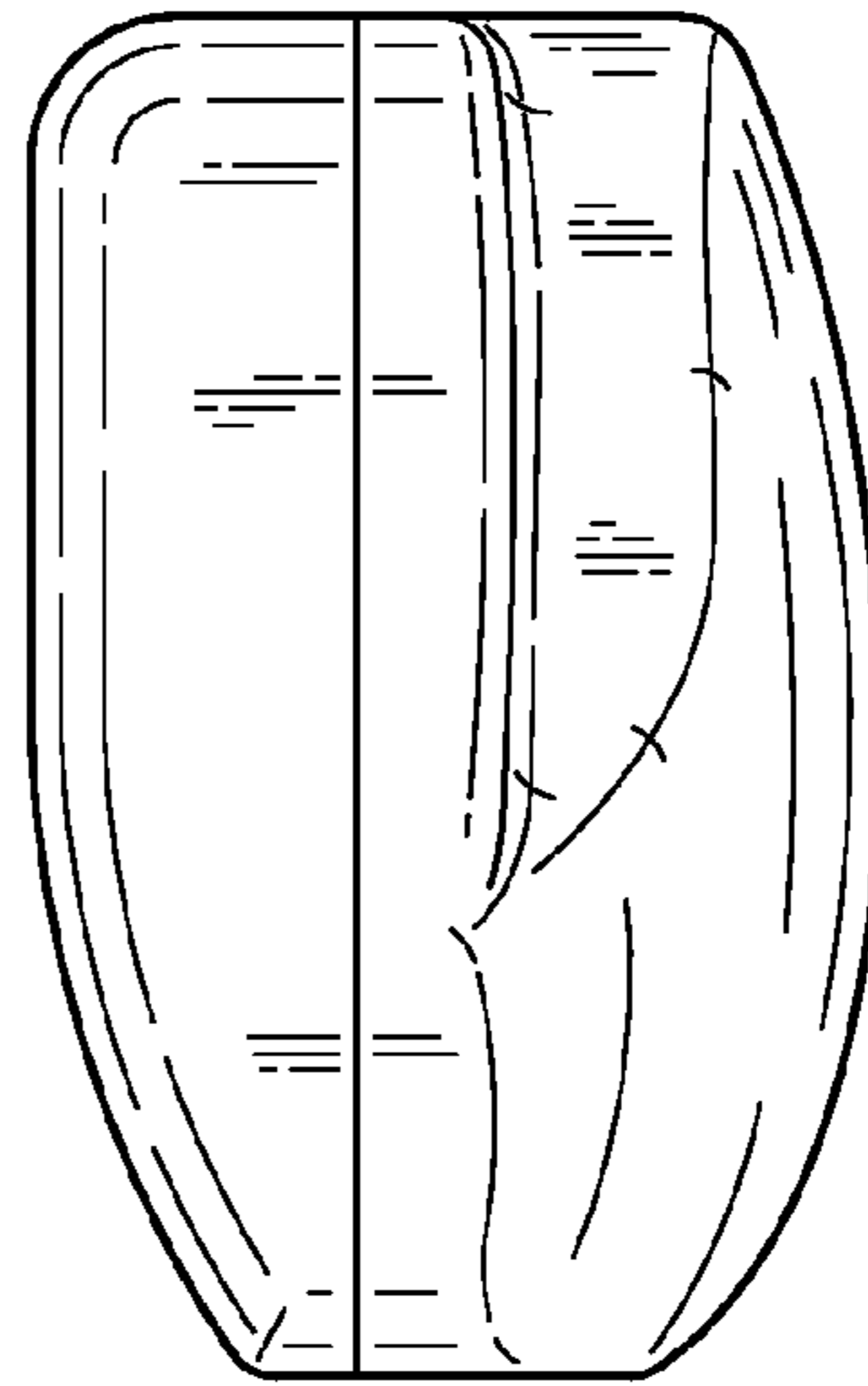

FIG. 6

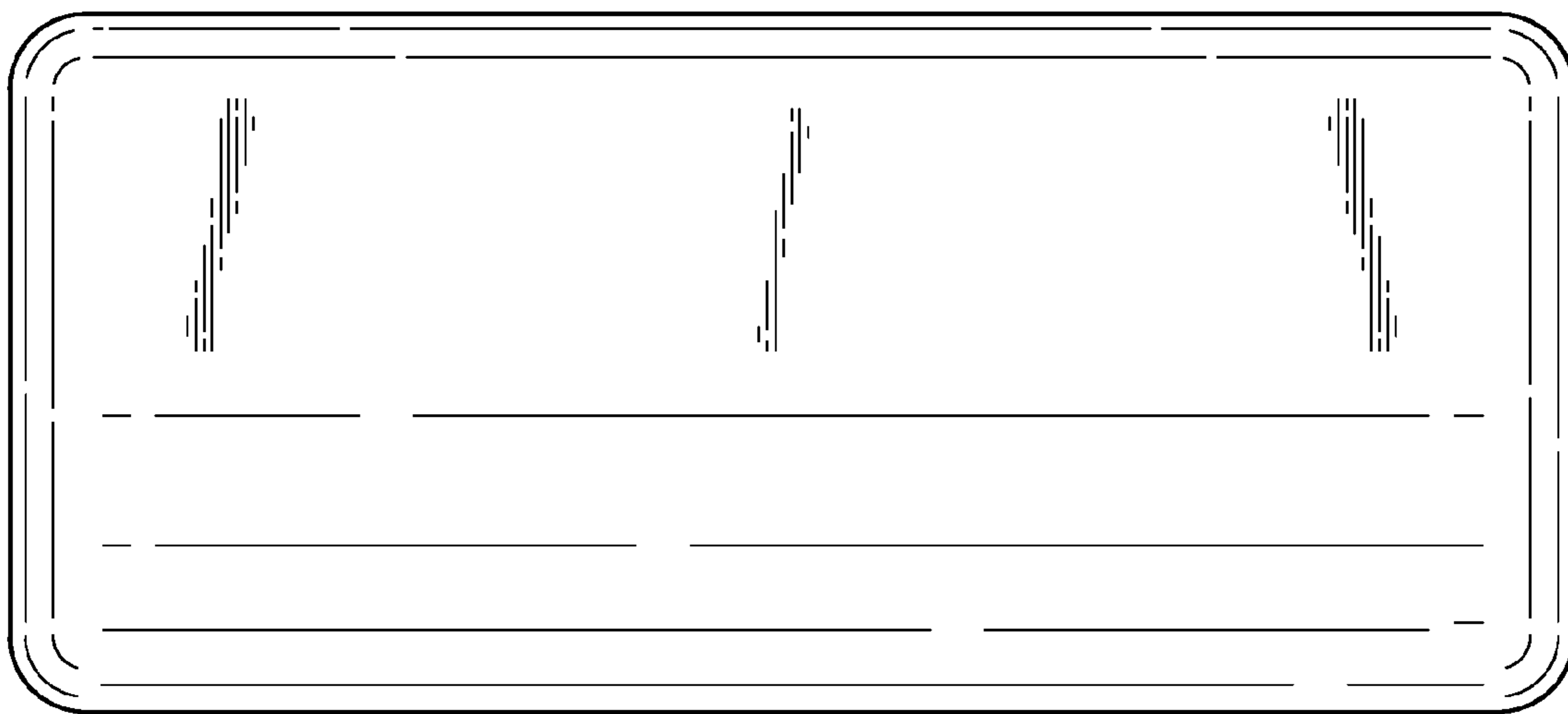

FIG. 7

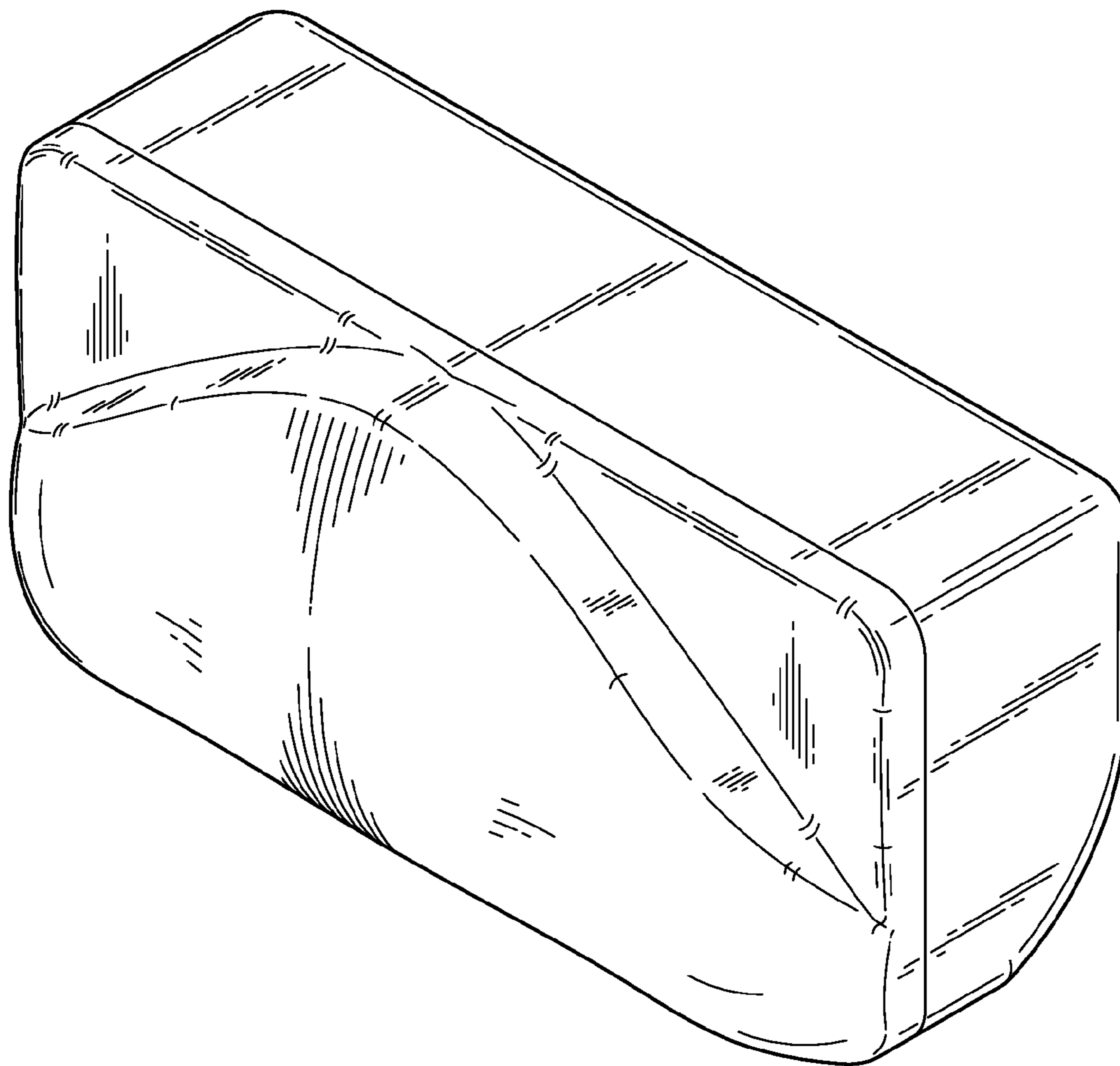

FIG. 8

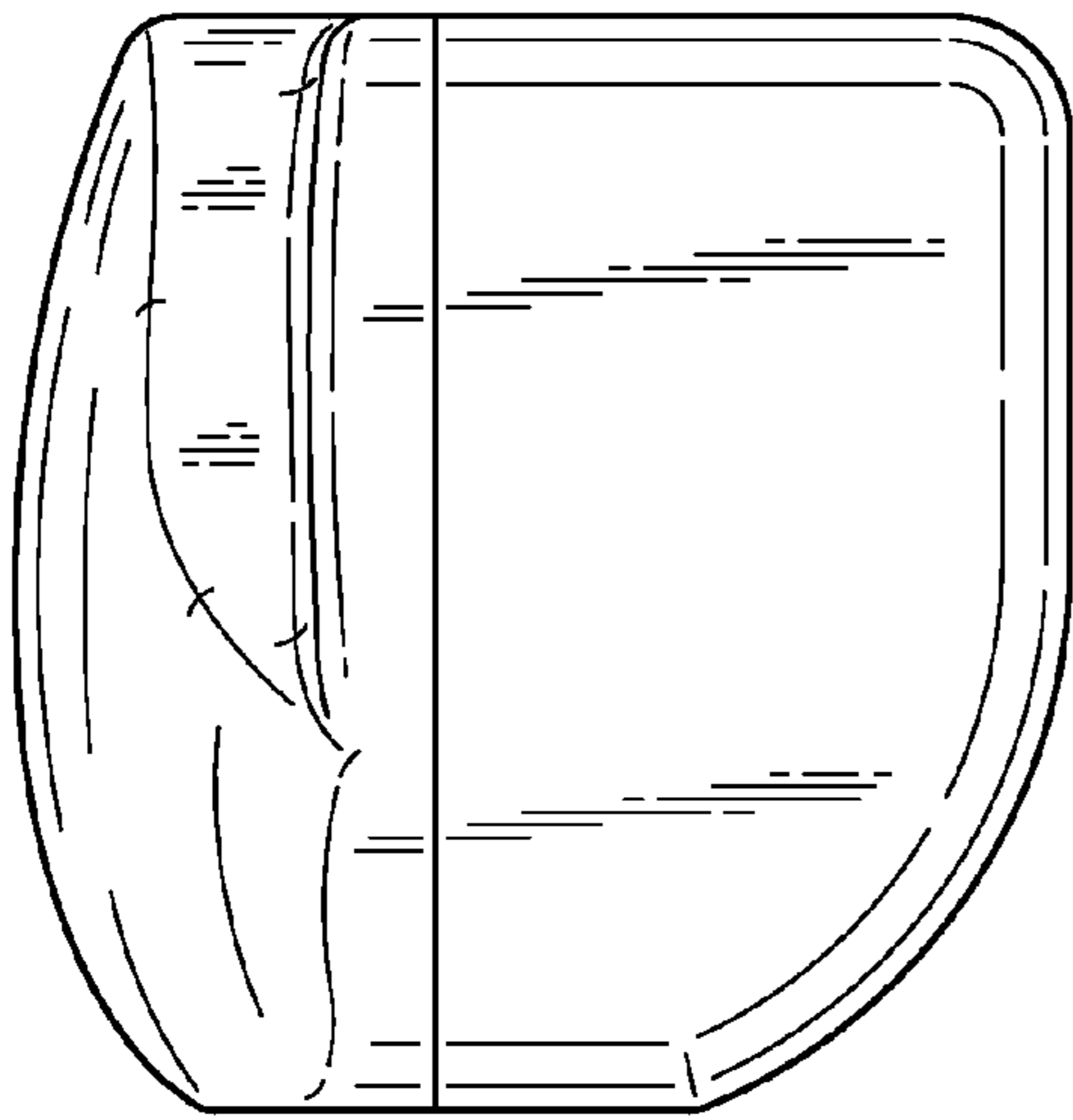

FIG. 9

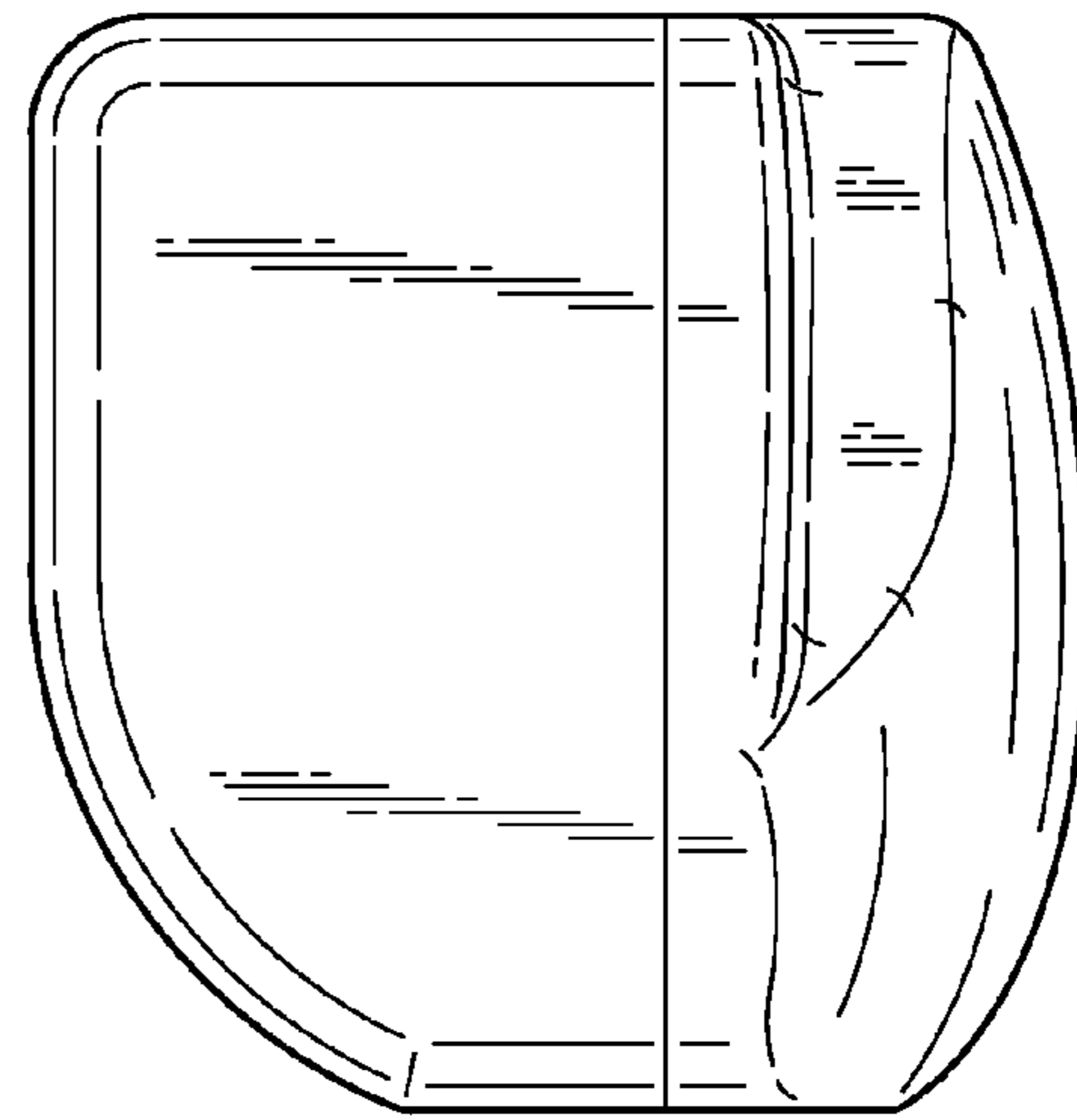

FIG. 10

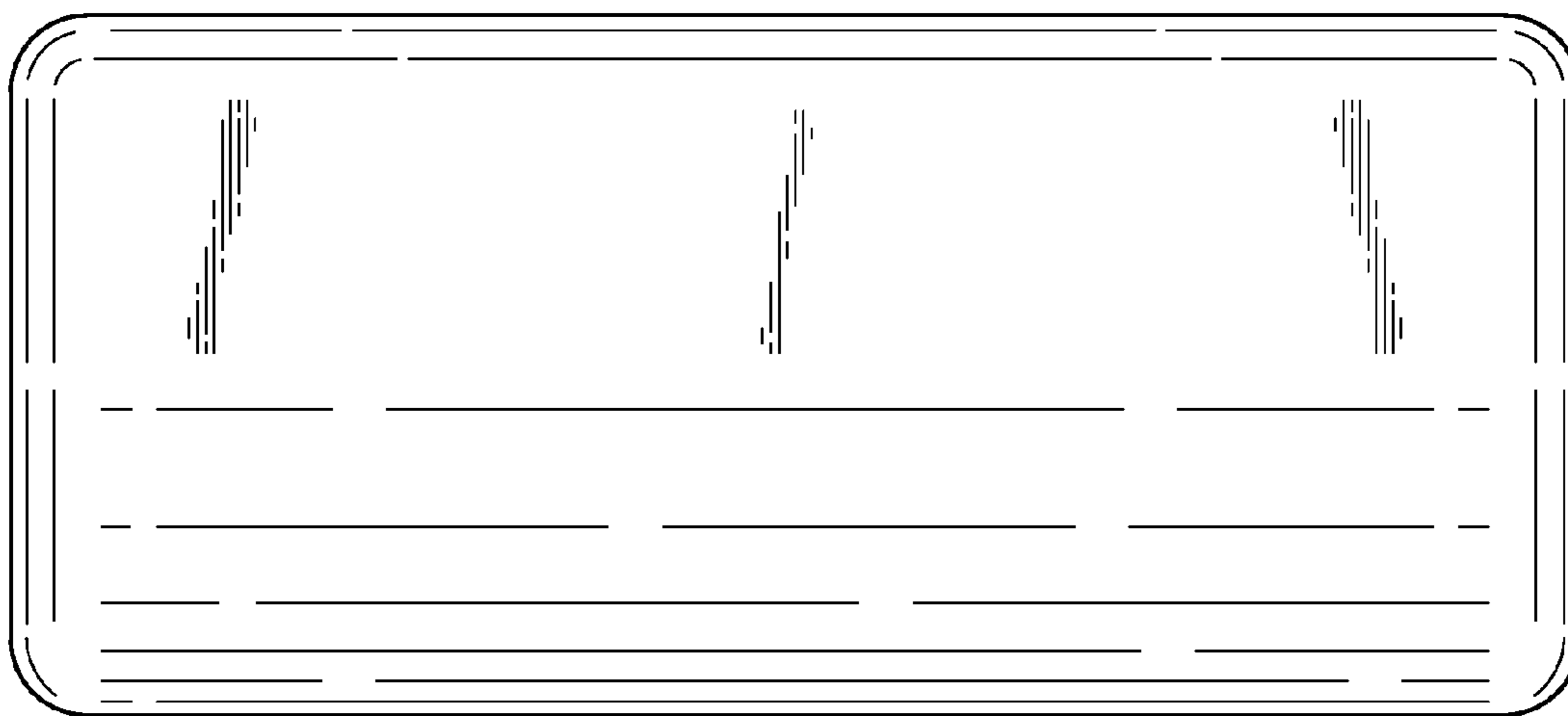

FIG. 11

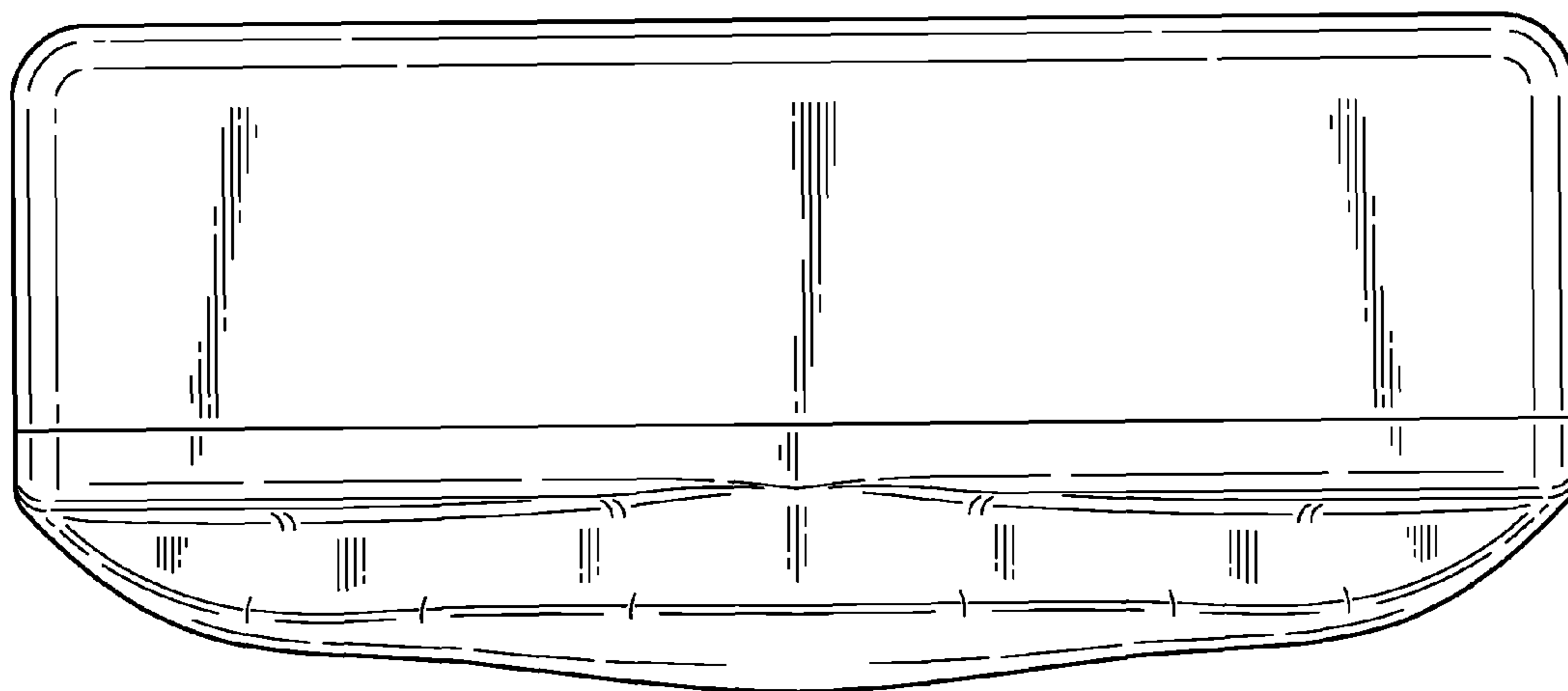

FIG. 12

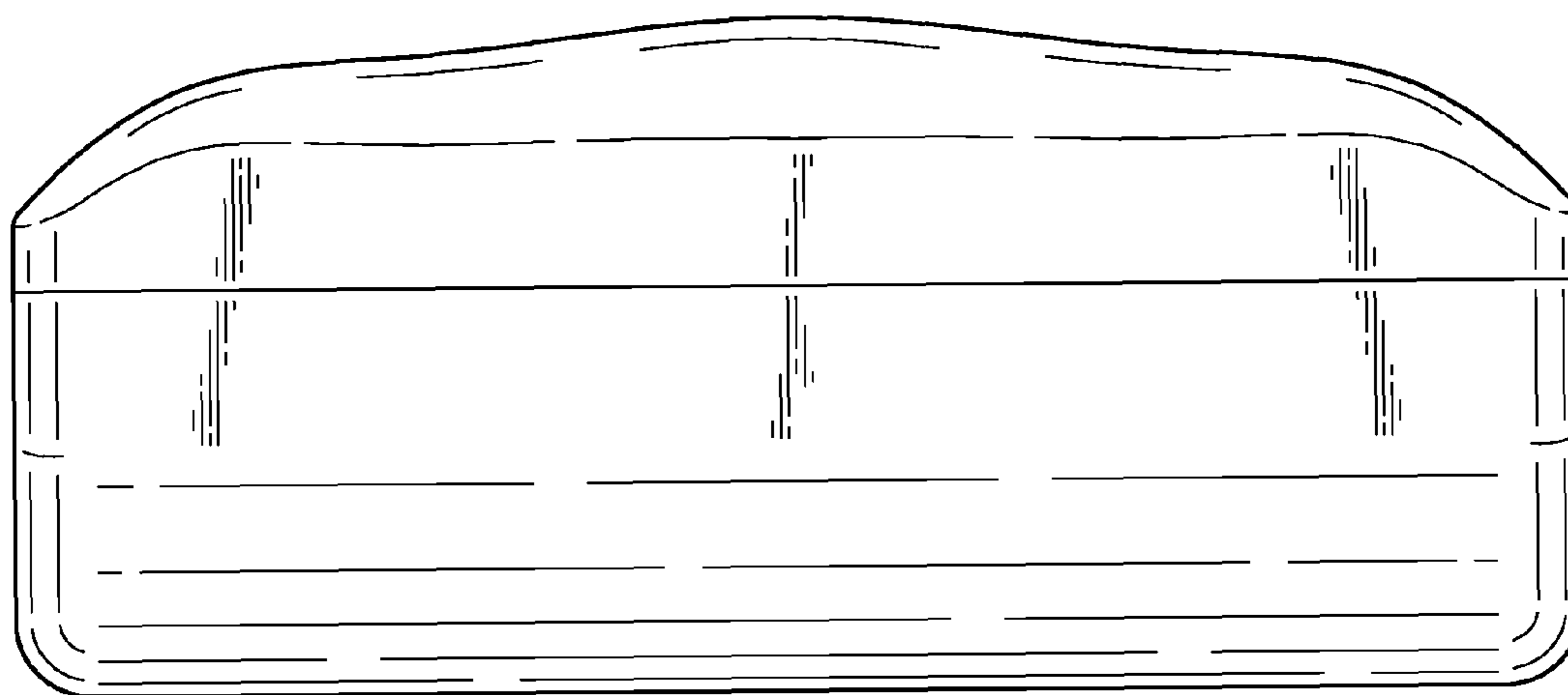

FIG. 13