



US00D629030S

(12) **United States Design Patent**
Long et al.

(10) **Patent No.:** **US D629,030 S**

(45) **Date of Patent:** **** Dec. 14, 2010**

(54) **MANIPULATOR**

D616,909 S * 6/2010 Long D15/199
D624,104 S * 9/2010 Miyake et al. D15/199

(75) Inventors: **Bo Long**, Shenzhen (CN); **Xiao-Ming Xu**, Shenzhen (CN)

* cited by examiner

(73) Assignee: **Hon Hai Precision Industry Co., Ltd.**,
Tu-Cheng, Taipei Hsien (TW)

Primary Examiner—Patricia Palasik
(74) *Attorney, Agent, or Firm*—Clifford O. Chi

(**) Term: **14 Years**

(57) **CLAIM**

(21) Appl. No.: **29/345,699**

The ornamental design for a manipulator, as shown and described.

(22) Filed: **Oct. 21, 2009**

DESCRIPTION

(51) **LOC (9) Cl.** **15-99**

(52) **U.S. Cl.** **D15/199**

(58) **Field of Classification Search** D15/122,
D15/199; D24/176; 74/490.01, 490.02,
74/490.03, 490.05; 219/124.34, 639; 318/560;
700/99, 150

See application file for complete search history.

FIG. 1 is a perspective view of a manipulator showing my design, the manipulator including a movable arm in a first position;

FIG. 2 is similar to FIG. 1, but viewed from another aspect;

FIG. 3 is a front elevational view thereof;

FIG. 4 is a rear elevational view thereof;

FIG. 5 is a left side elevational view thereof;

FIG. 6 is a right side elevational view thereof;

FIG. 7 is a top plan view thereof;

FIG. 8 is a bottom plan view thereof;

FIG. 9 is a perspective view of the manipulator in FIG. 1, the movable arm in a second position;

FIG. 10 is a perspective view of the manipulator in FIG. 1, the movable arm in a third position;

FIG. 11 is a perspective view of the manipulator in FIG. 1, the movable arm in a fourth position; and,

FIG. 12 is a perspective view of the manipulator in FIG. 1, the movable arm in a fifth position.

The broken lines in FIGS. 1 through 12 are included for the purposes of illustrating environment only and form no part of the claimed design.

(56) **References Cited**

U.S. PATENT DOCUMENTS

4,273,506	A *	6/1981	Thomson et al.	414/735
D279,572	S *	7/1985	Yasuoka et al.	D15/199
4,586,868	A *	5/1986	Nakashima et al.	414/735
D293,449	S *	12/1987	Kaufmann et al.	D15/199
4,773,813	A *	9/1988	Nakashima et al.	414/680
D344,280	S *	2/1994	Koyama et al.	D15/199
5,564,312	A *	10/1996	Brunman et al.	74/490.02
5,901,613	A *	5/1999	Forslund 74/490.03	
D410,477	S *	6/1999	Nihei et al.	D15/199
D423,534	S *	4/2000	Raab et al.	D15/199
D443,287	S *	6/2001	Kawahara et al.	D15/199
D444,488	S *	7/2001	Selic et al.	D15/199
D478,921	S *	8/2003	Kullborg et al.	D15/199
D610,926	S *	3/2010	Gerent et al.	D10/63
D613,781	S *	4/2010	Liu et al.	D15/199
D615,574	S *	5/2010	Liu et al.	D15/199
D616,477	S *	5/2010	Long et al.	D15/199

1 Claim, 12 Drawing Sheets

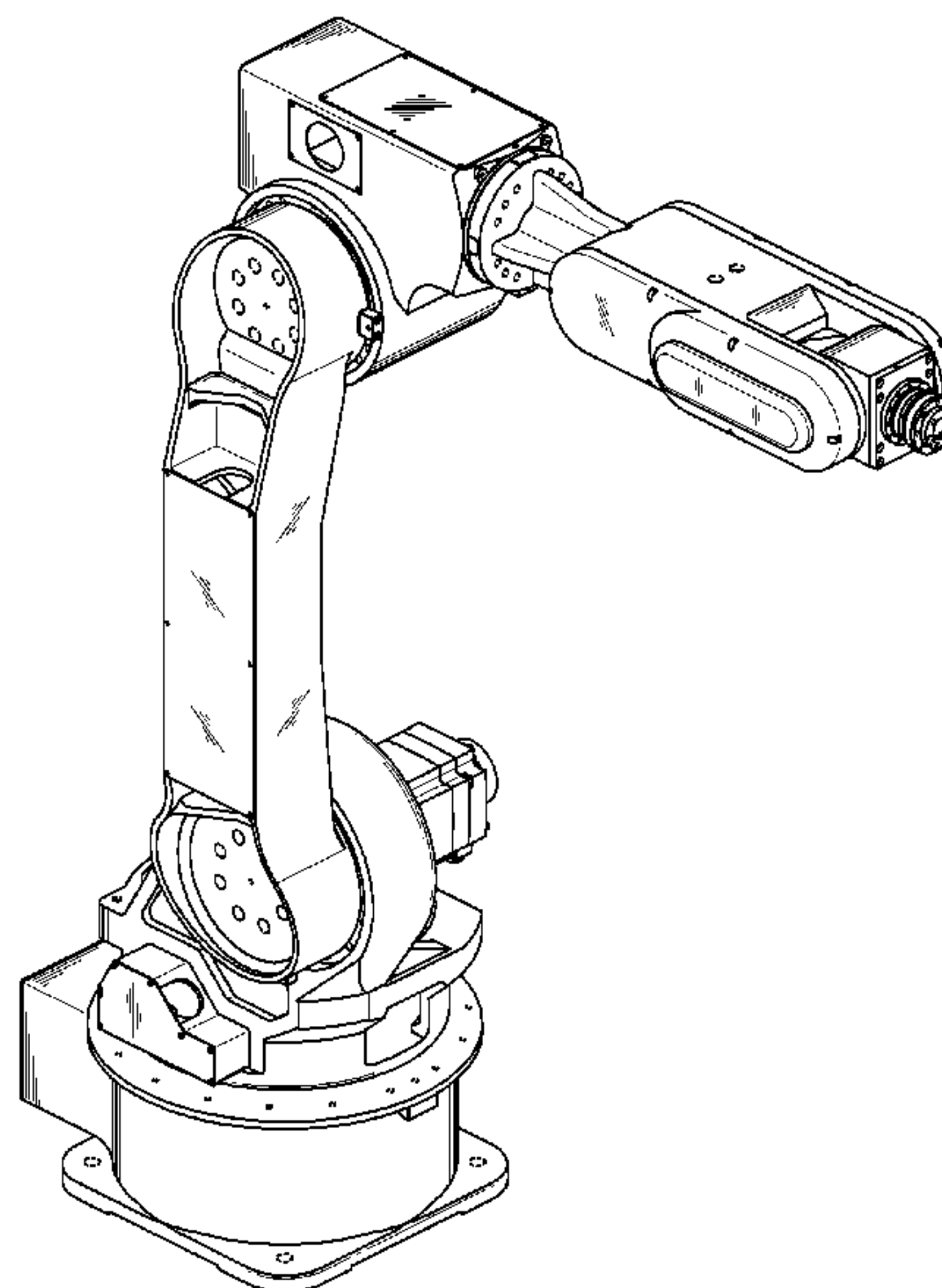

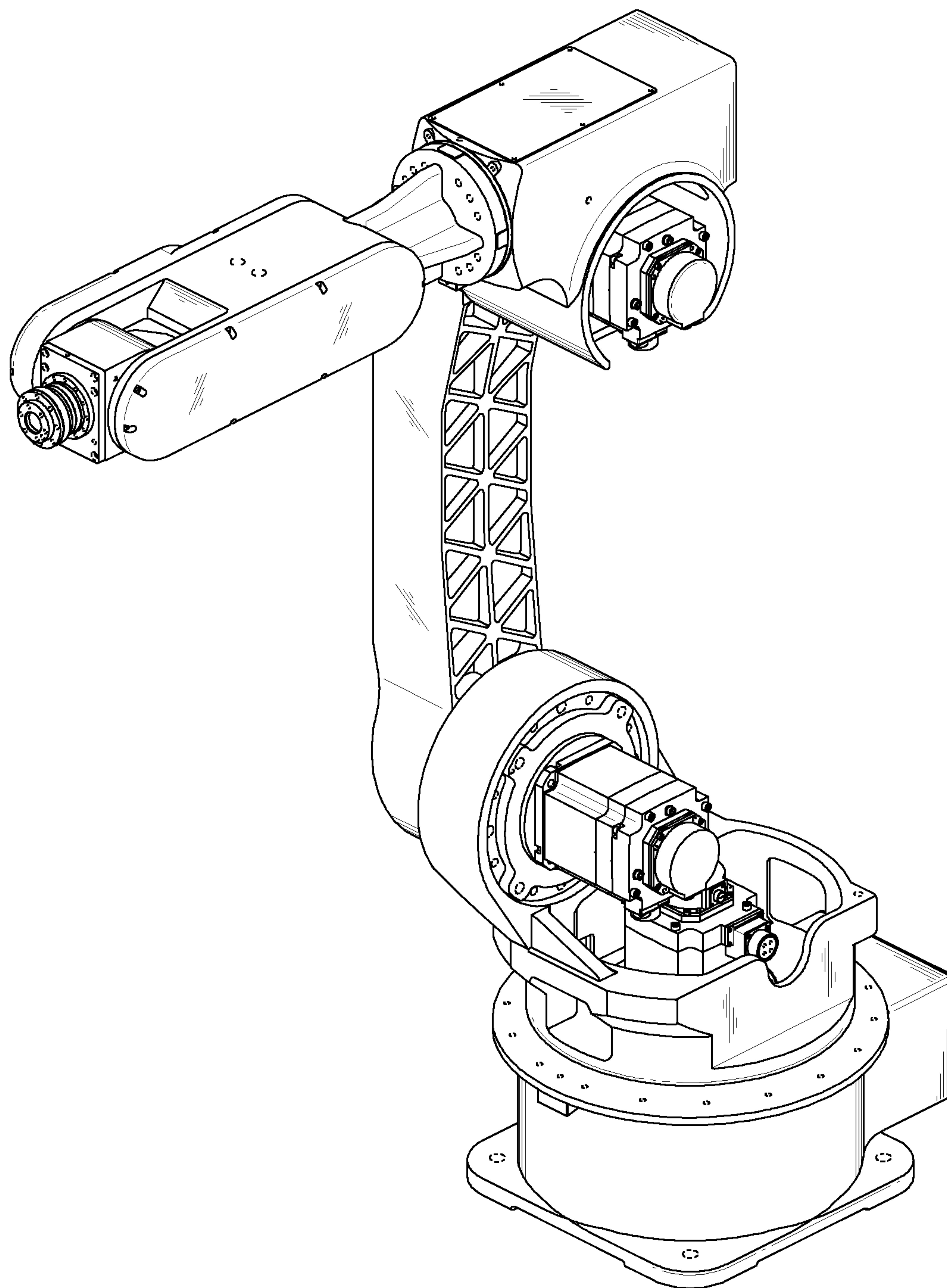

FIG. 1

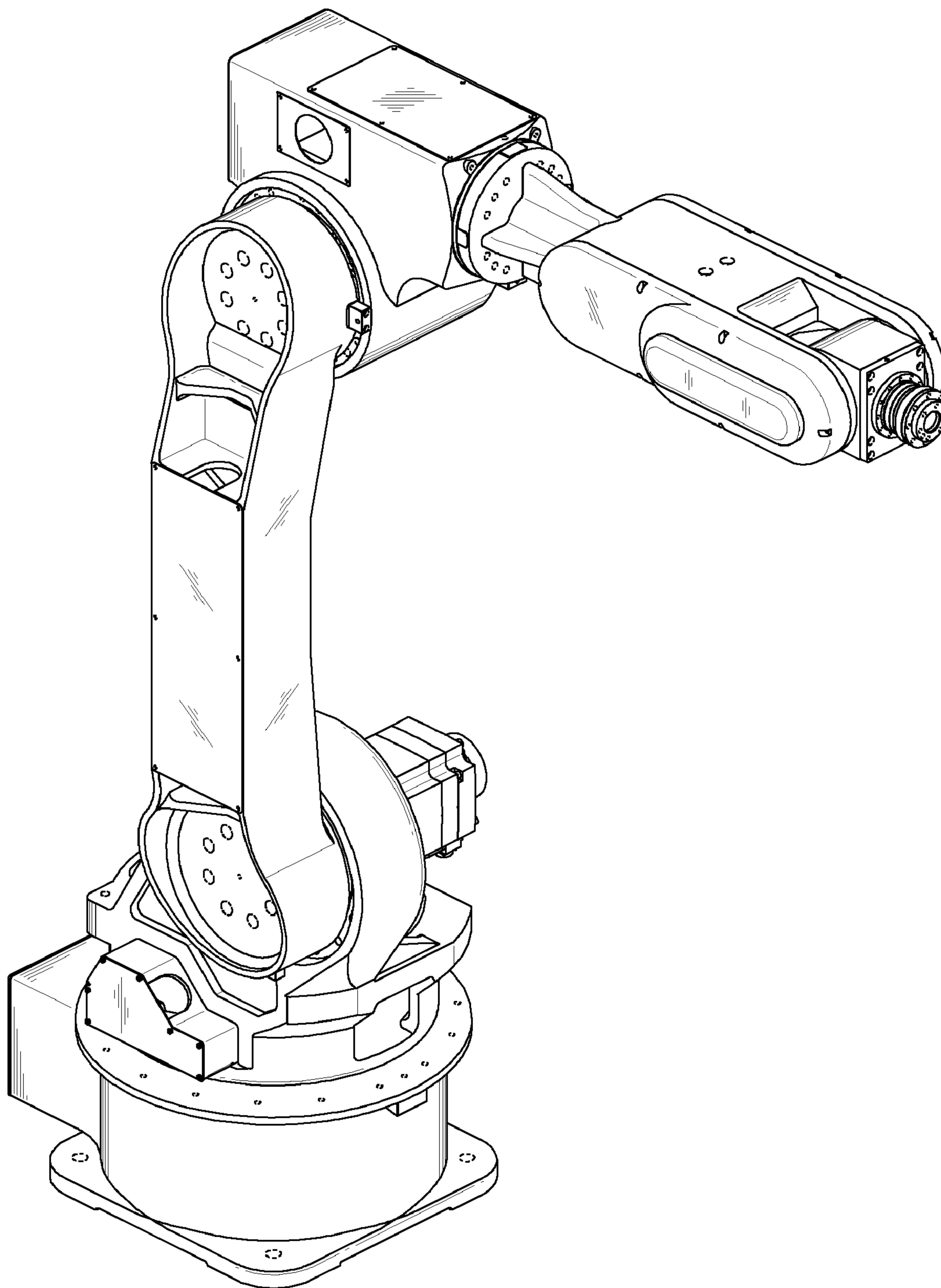

FIG. 2

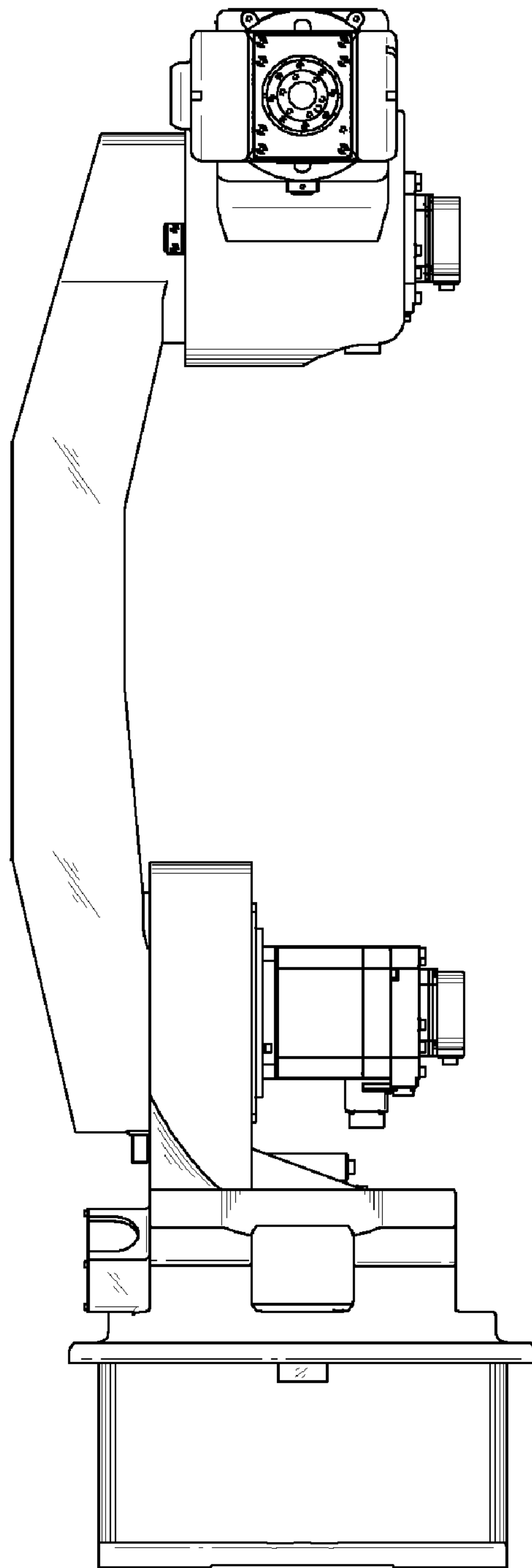

FIG. 3

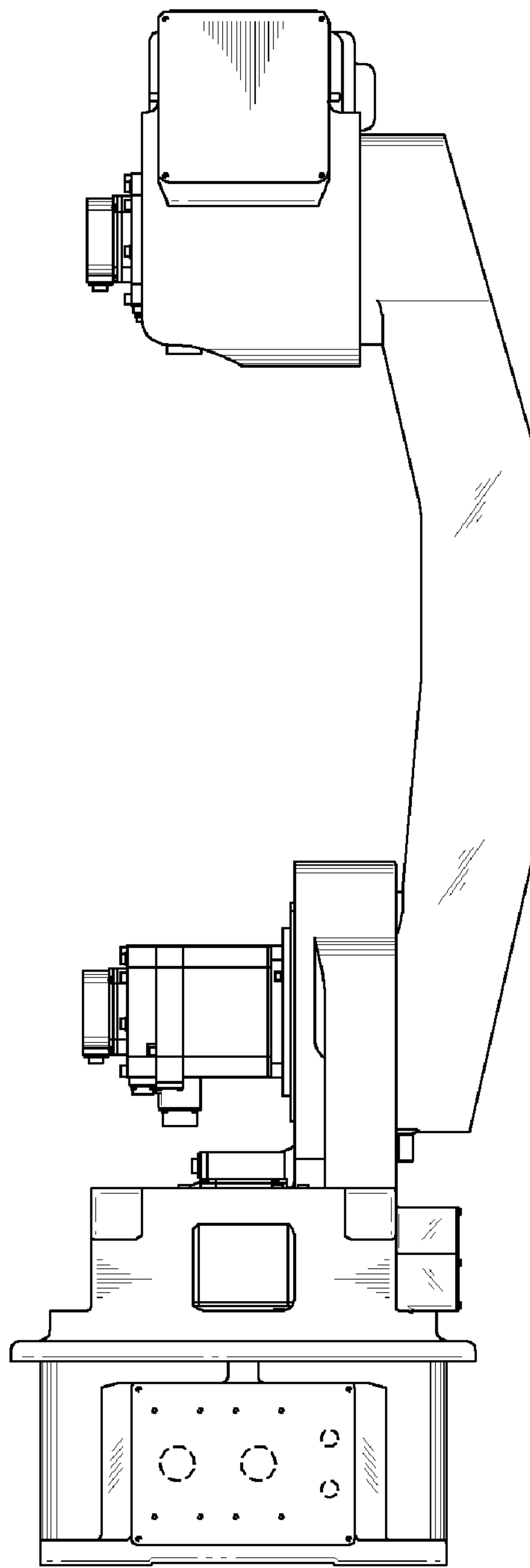

FIG. 4

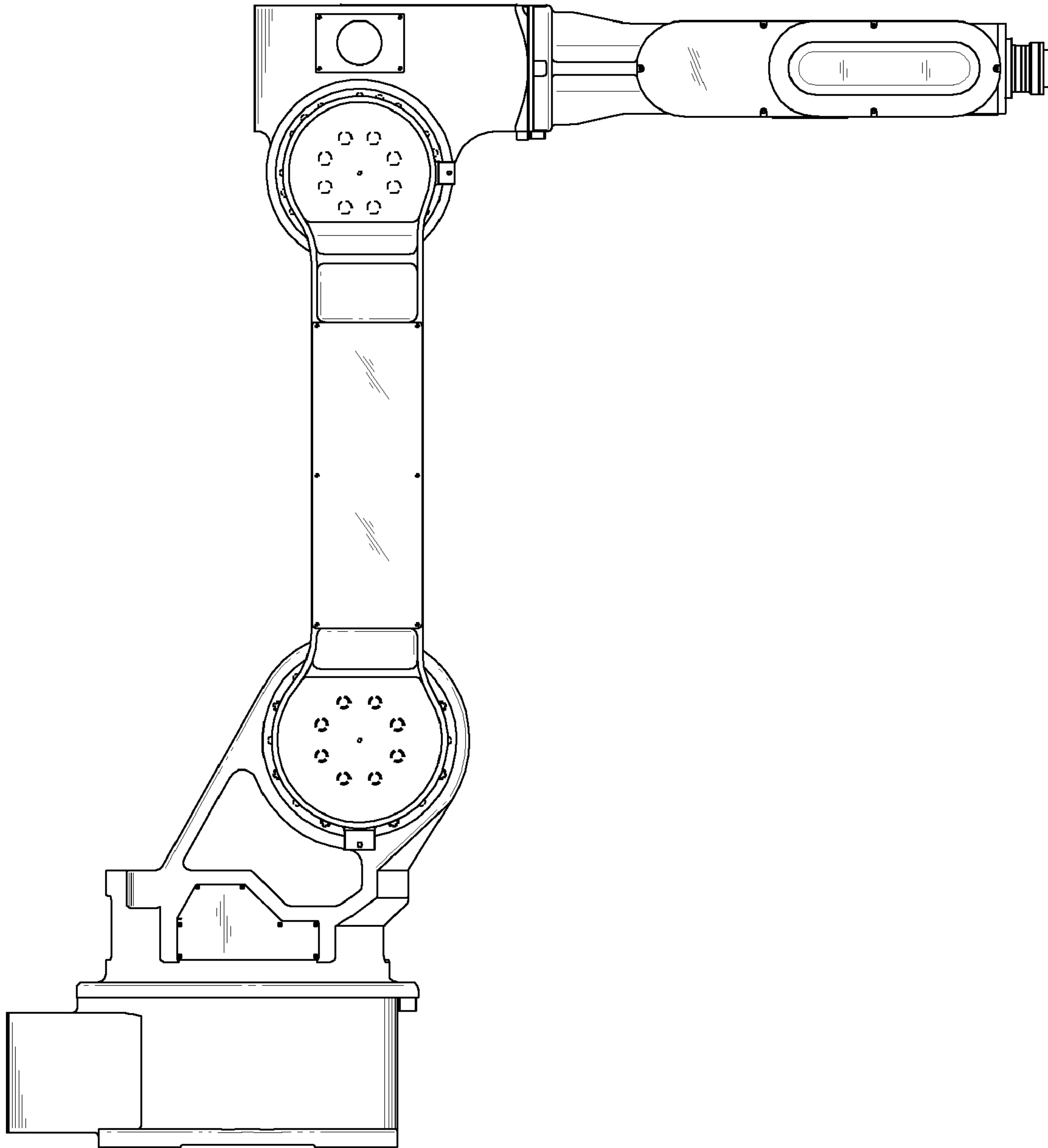

FIG. 5

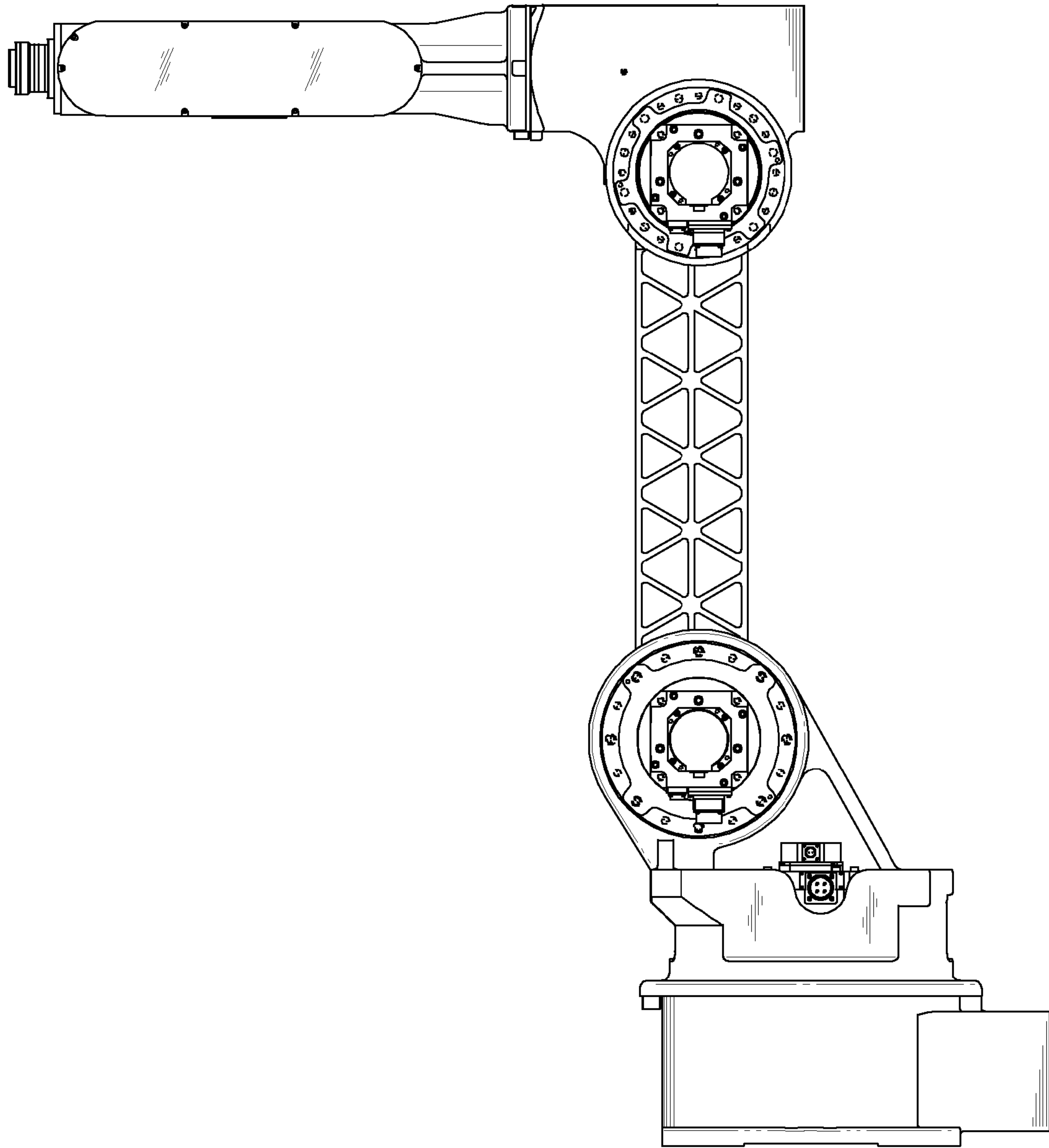

FIG. 6

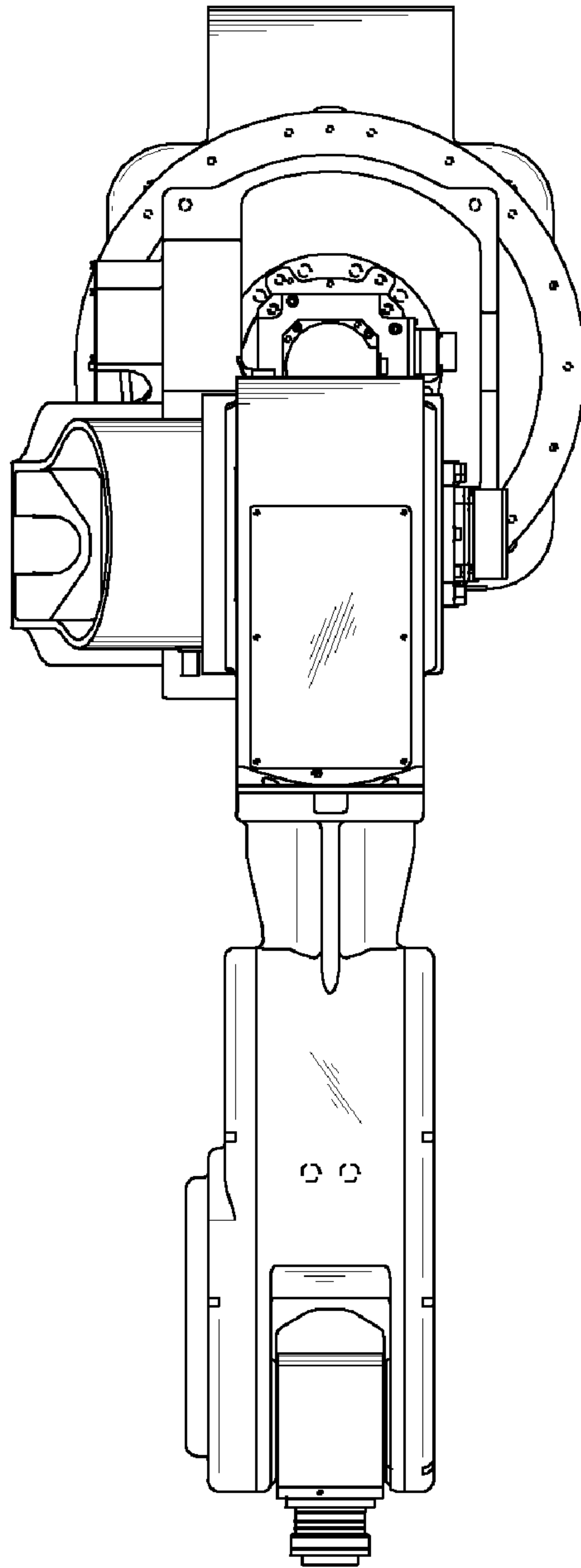

FIG. 7

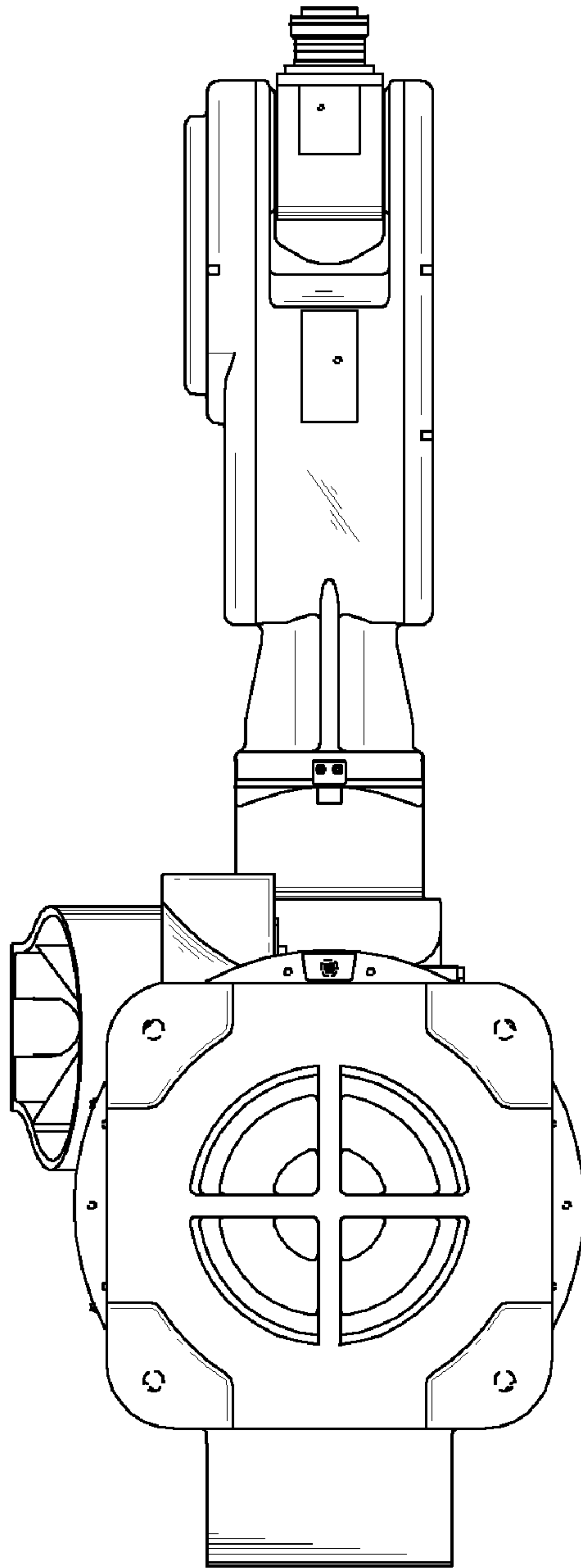

FIG. 8

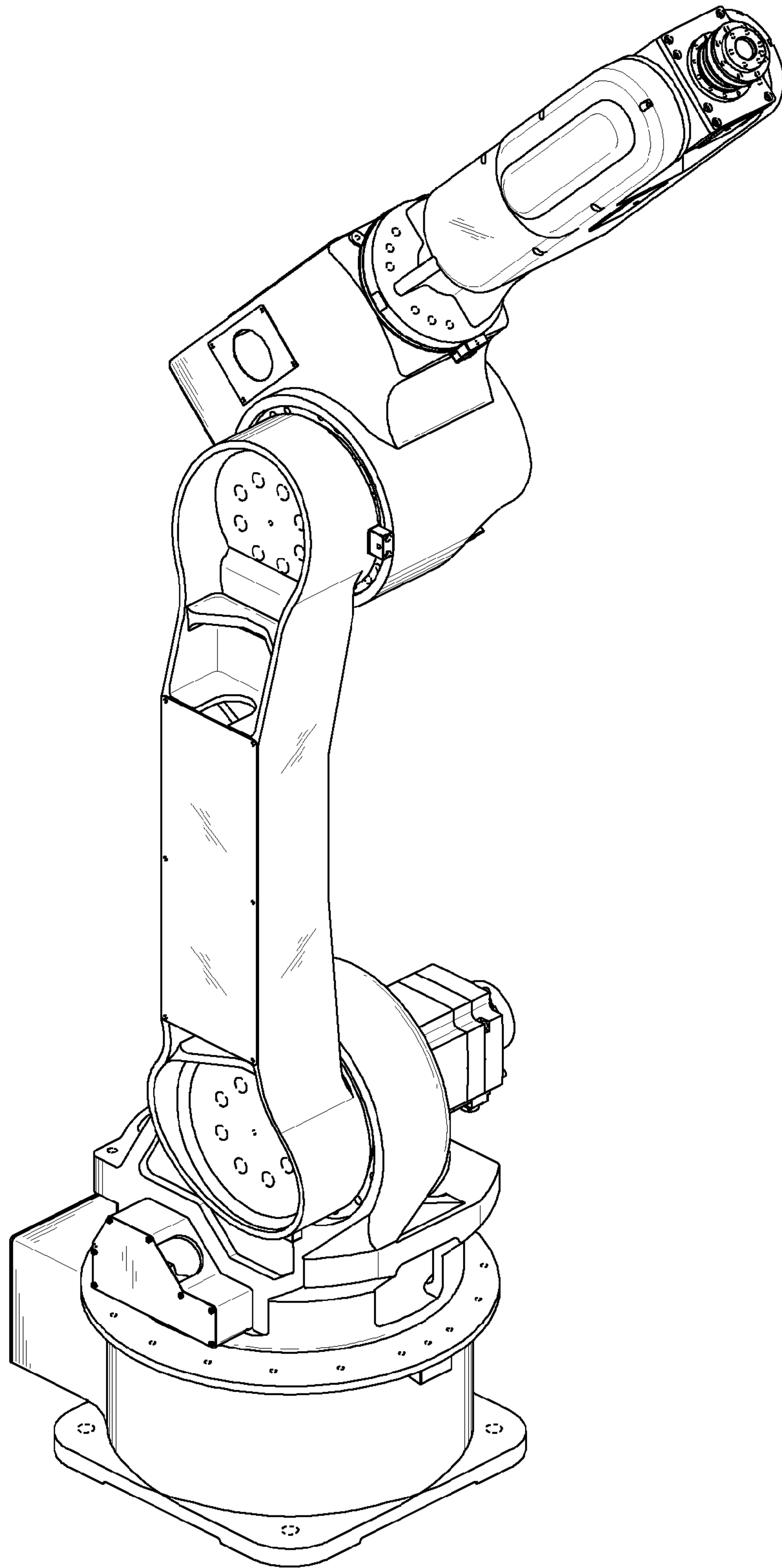

FIG. 9

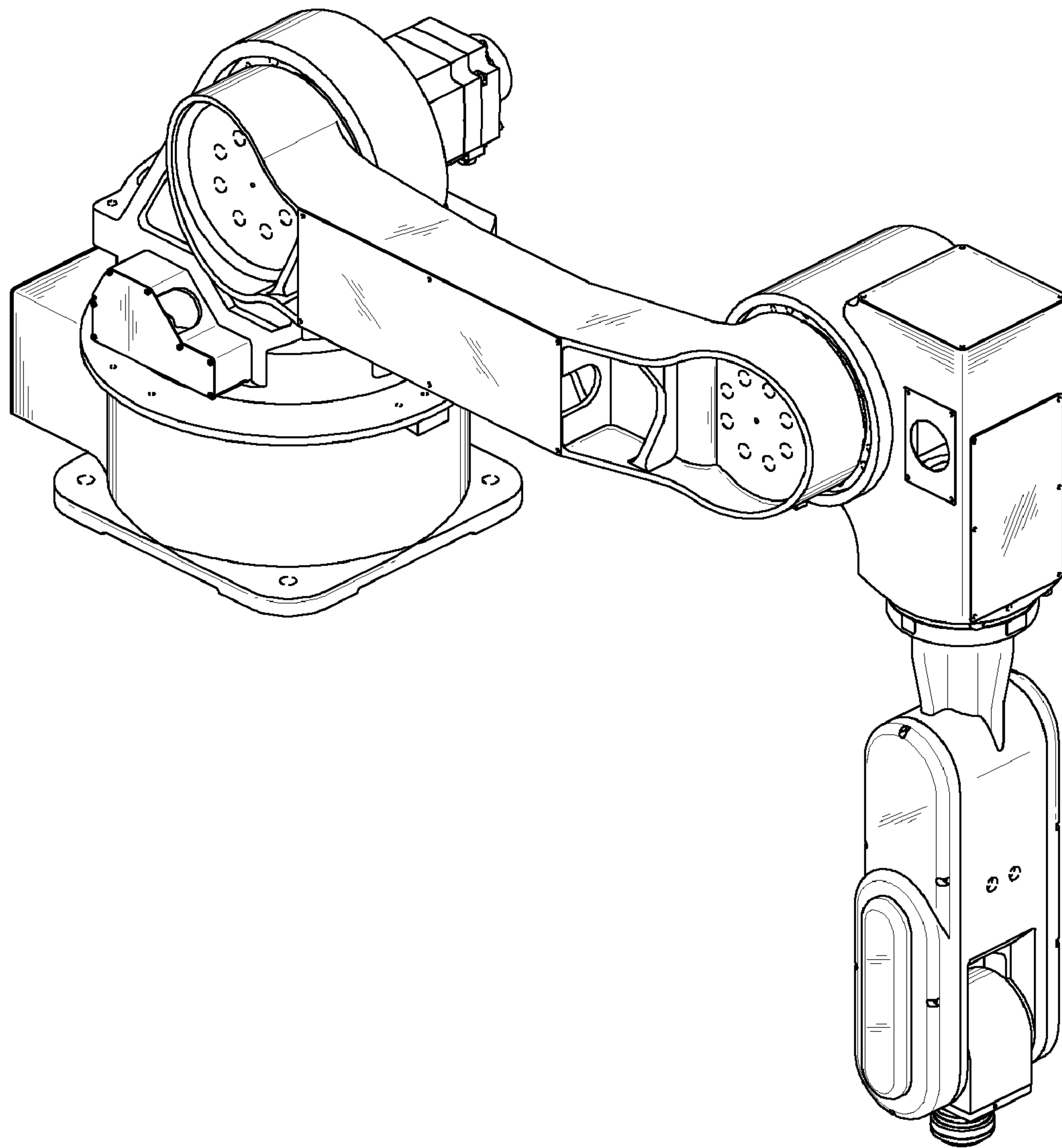

FIG. 10

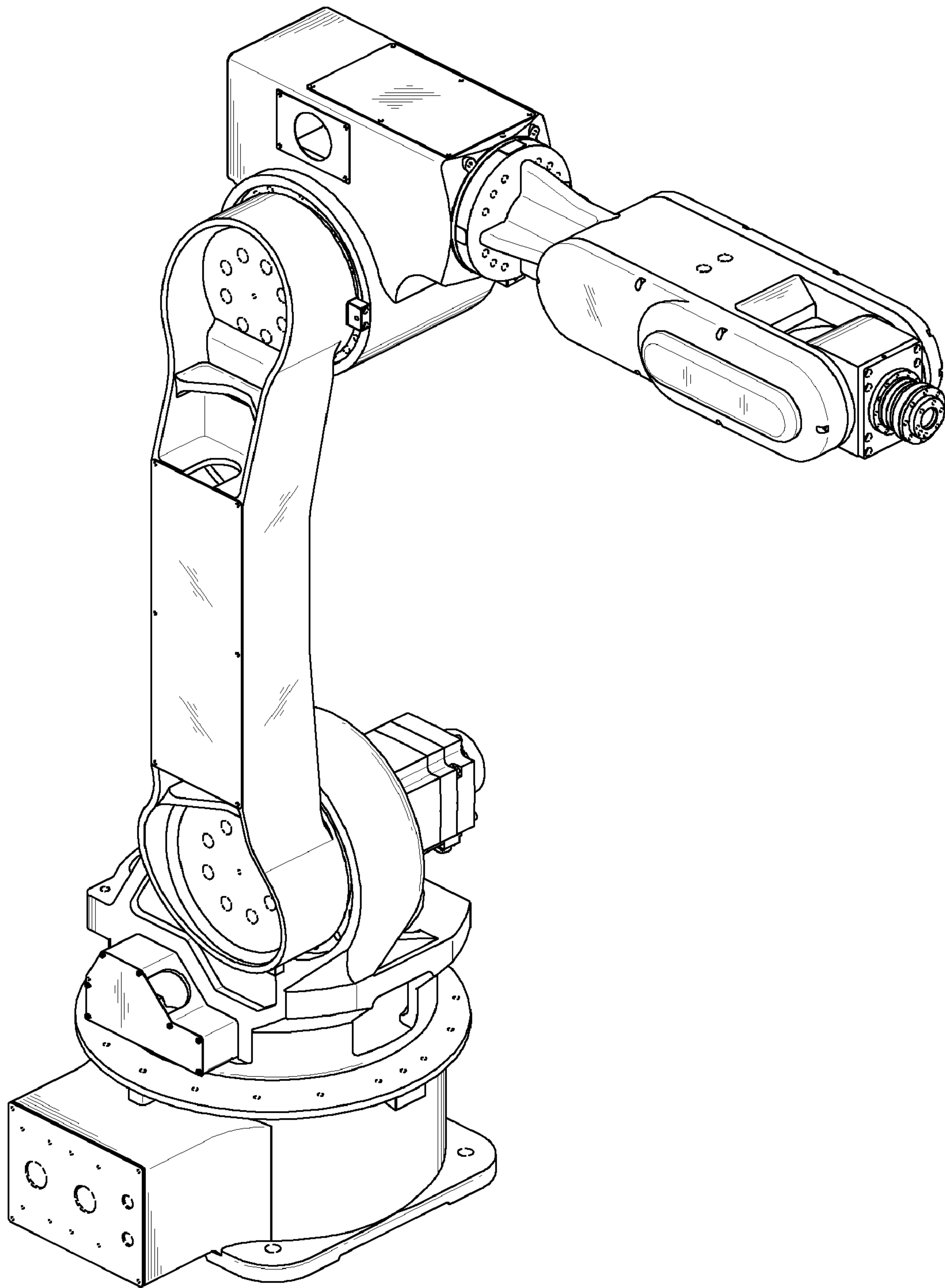

FIG. 11

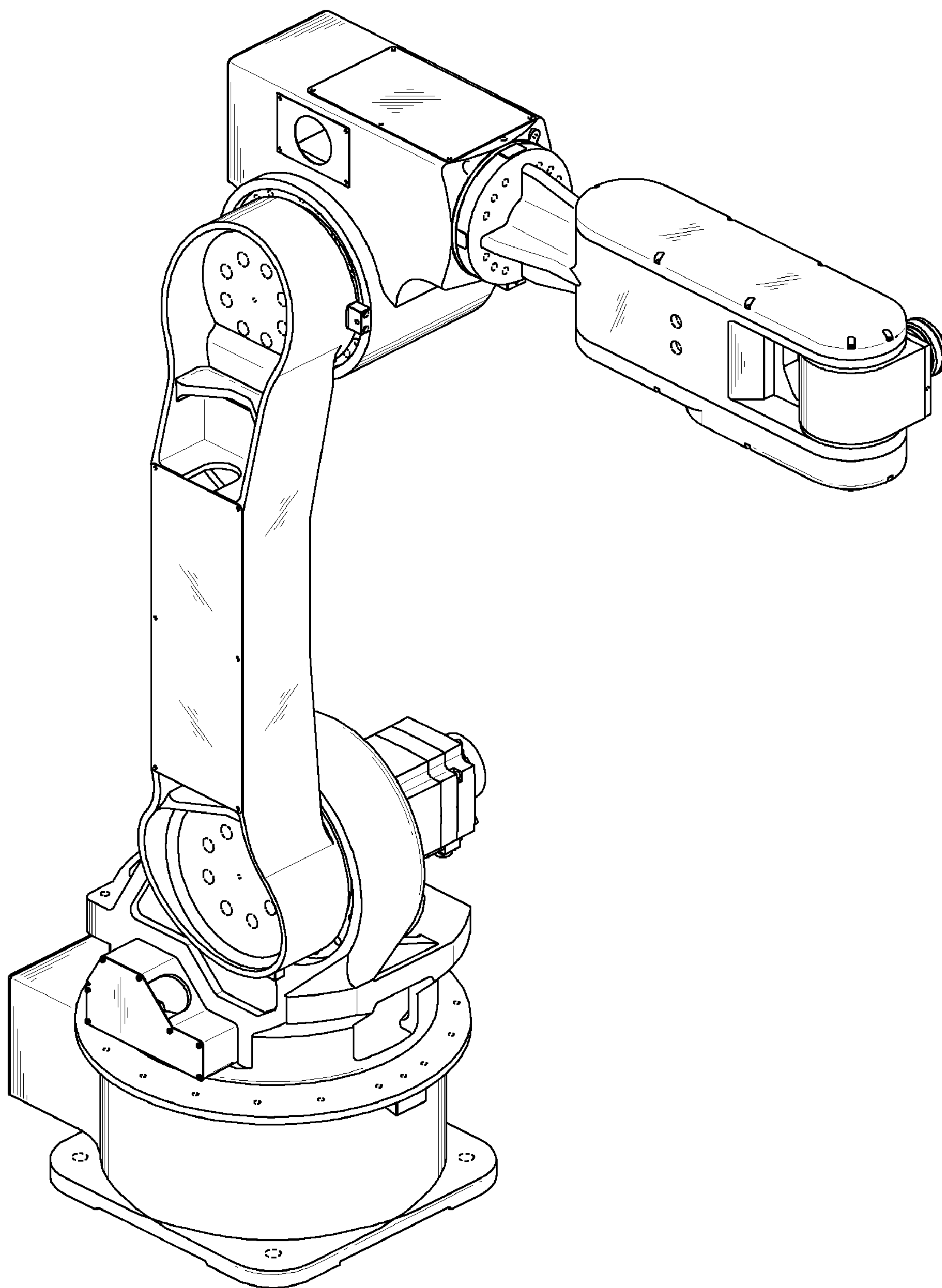

FIG. 12