



US00D628960S

(12) **United States Design Patent**  
**Shimizu et al.**

(10) **Patent No.:** **US D628,960 S**

(45) **Date of Patent:** **\*\* Dec. 14, 2010**

(54) **CHARGER FOR AUTOMOBILE**

D613,683 S \* 4/2010 Baxter et al. .... D13/107  
D618,168 S \* 6/2010 Baxter et al. .... D13/107

(75) Inventors: **Akio Shimizu**, Kanagawa (JP); **Daisuke Yasuhara**, Kanagawa (JP)

**OTHER PUBLICATIONS**

(73) Assignee: **Nissan Jidosha Kabushiki Kaisha**, Kanagawa (JP)

U.S. Appl. No. 29/348,462, filed Jan. 8, 2010; first named inventor: Akio Shimizu et al.

(\*\*) Term: **14 Years**

\* cited by examiner

(21) Appl. No.: **29/348,463**

*Primary Examiner*—Rosemary K Tarcza

(22) Filed: **Jan. 8, 2010**

(74) *Attorney, Agent, or Firm*—Fross Zelnick Lehrman & Zissu, P.C.; Lawrence E. Apolzon, Esq.

(30) **Foreign Application Priority Data**

Jul. 9, 2009 (JP) ..... 2009-015730

(57) **CLAIM**

The ornamental design for a charger for automobile, as shown and described.

(51) **LOC (9) Cl.** ..... **13-02**

**DESCRIPTION**

(52) **U.S. Cl.** ..... **D13/107**

(58) **Field of Classification Search** ..... D13/107–110, D13/118–119, 139.5, 184; D14/251, 253, D14/432, 434, 435.1; 320/107–115

FIG. 1 is a perspective view of the front, right side and top plan of a charger for automobile showing our new design;

FIG. 2 is a front view thereof;

See application file for complete search history.

FIG. 3 is a rear view thereof;

(56) **References Cited**

**U.S. PATENT DOCUMENTS**

- D237,718 S \* 11/1975 Bozich ..... D13/139.5
- D270,831 S \* 10/1983 Jensen ..... D13/139.5
- D358,951 S \* 6/1995 Raynor ..... D6/421
- D361,538 S \* 8/1995 Hill et al. .... D13/110
- 5,461,299 A \* 10/1995 Bruni ..... 320/108
- D434,001 S \* 11/2000 Sayger ..... D13/139.5
- 6,459,234 B2 \* 10/2002 Kajiura ..... 320/109
- D597,937 S \* 8/2009 Haw et al. .... D13/107
- D608,731 S \* 1/2010 Amit ..... D13/107
- D608,733 S \* 1/2010 Smith ..... D13/107
- D608,734 S \* 1/2010 Smith ..... D13/107

FIG. 4 is a left side view thereof;

FIG. 5 is a right side view thereof;

FIG. 6 is a top plan view thereof;

FIG. 7 is a bottom view thereof; and,

FIG. 8 is a perspective view of the charger shown in FIG. 1, shown in the context of usage with an automobile. The automobile, shown in dotted lines, is included for reference only and forms no part of the claimed design.

The portions shown in broken lines are of illustrative purposes only and form no part of the claimed design.

**1 Claim, 8 Drawing Sheets**

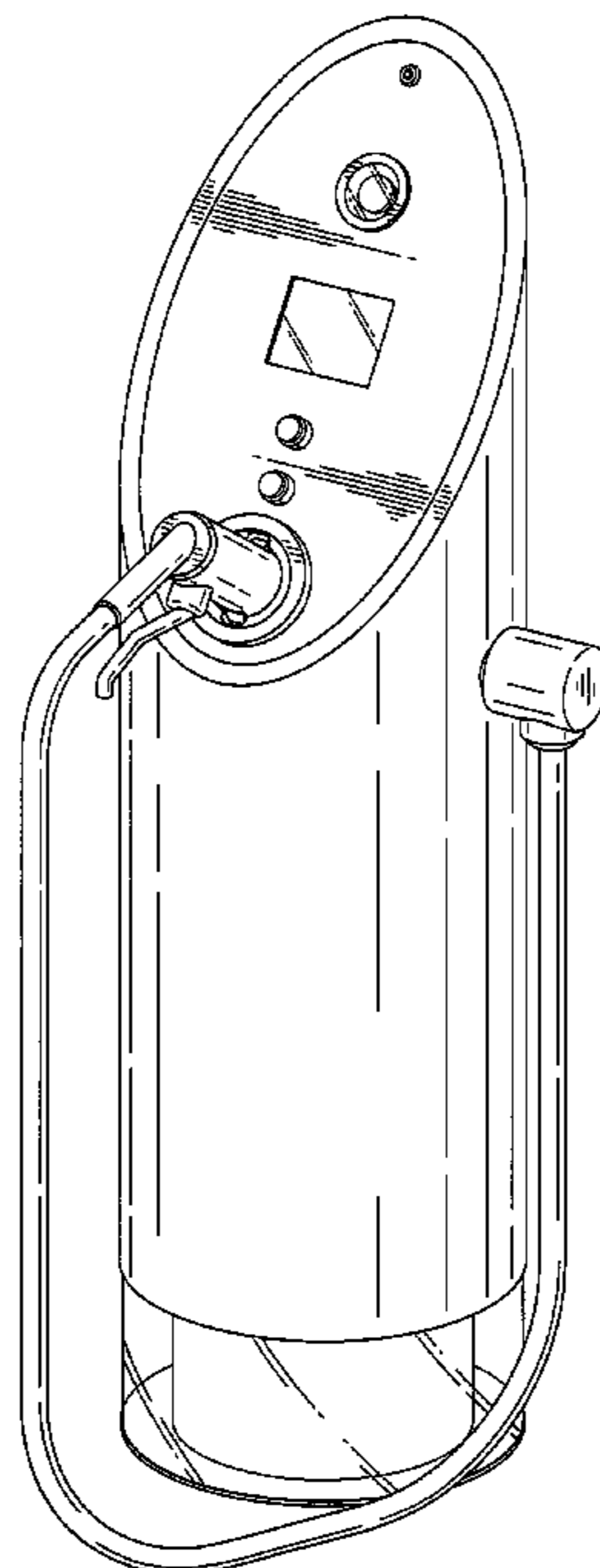

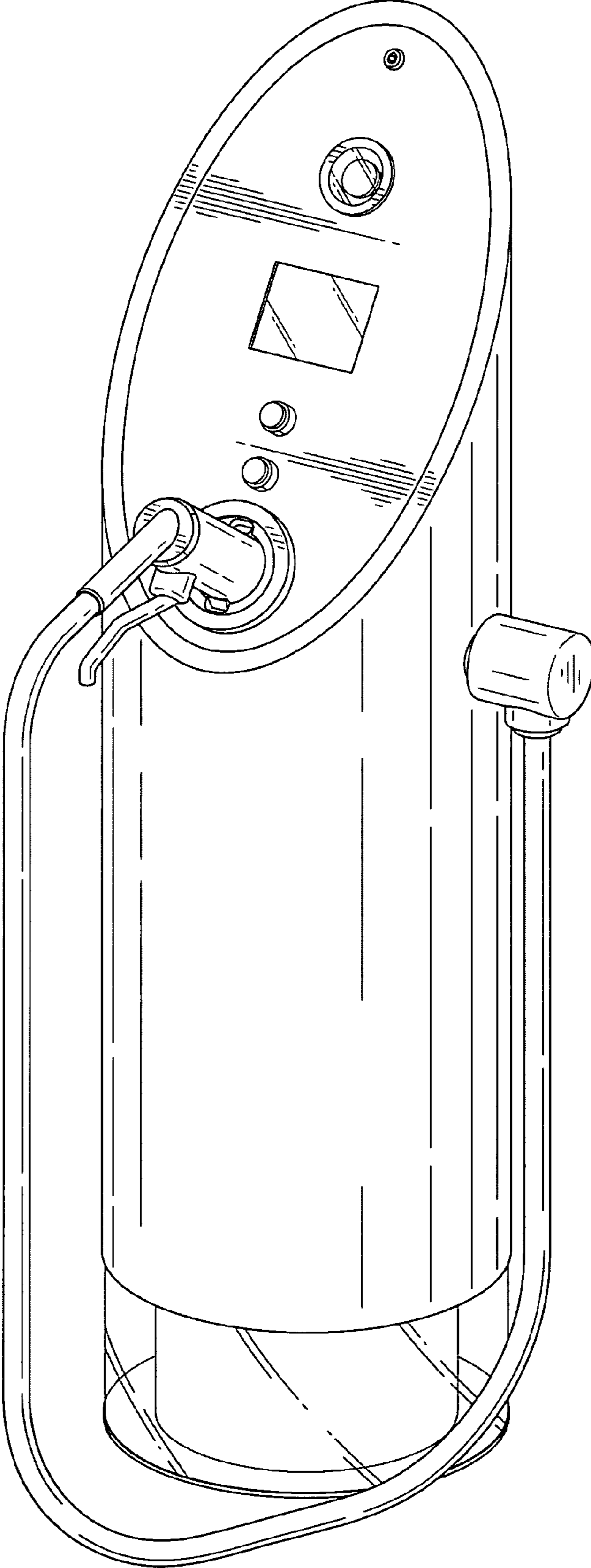

FIG. 1

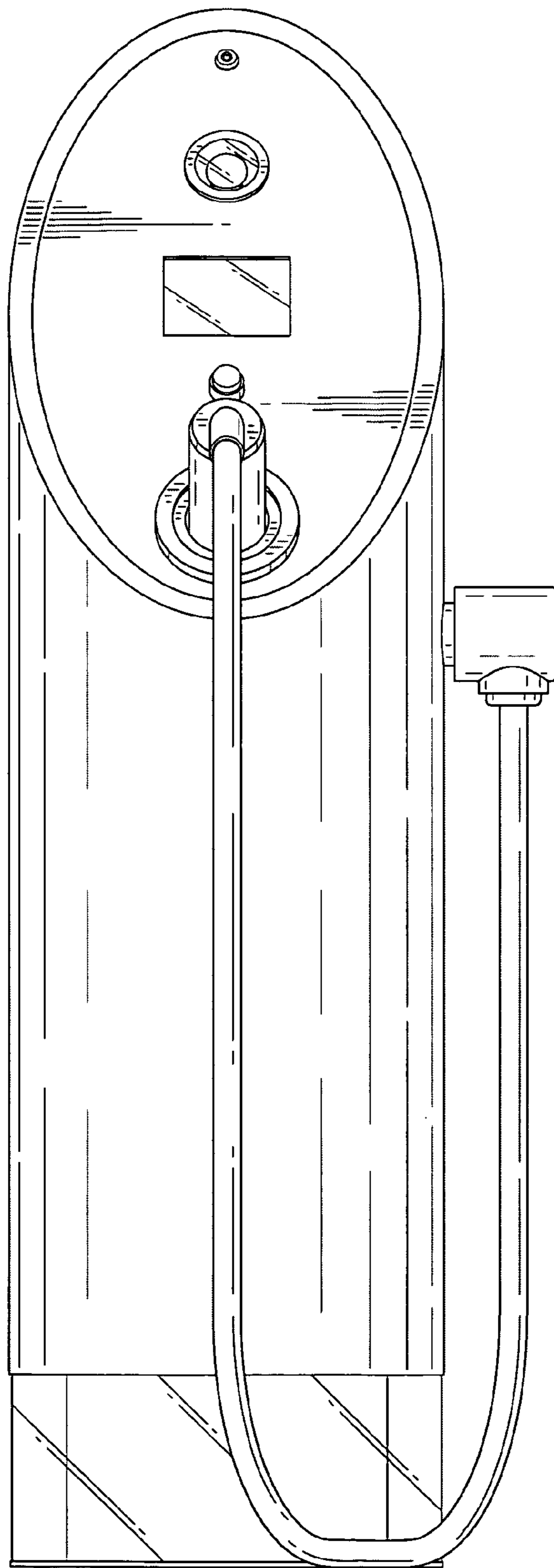

FIG. 2

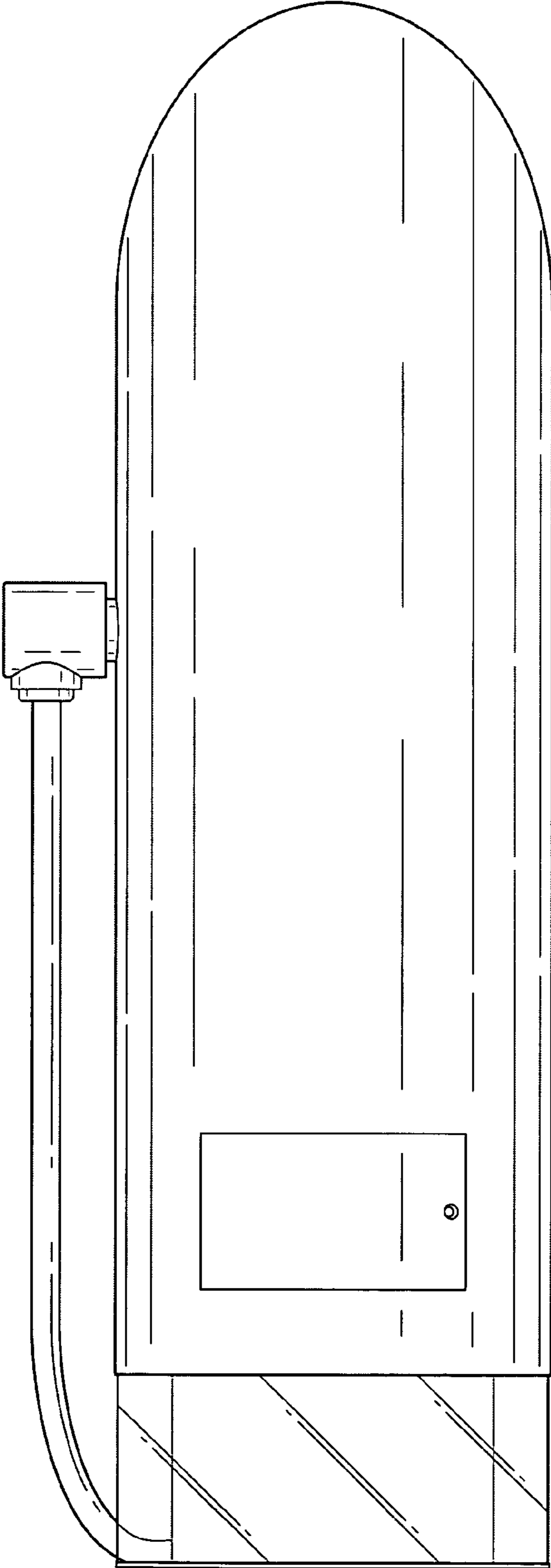

FIG. 3

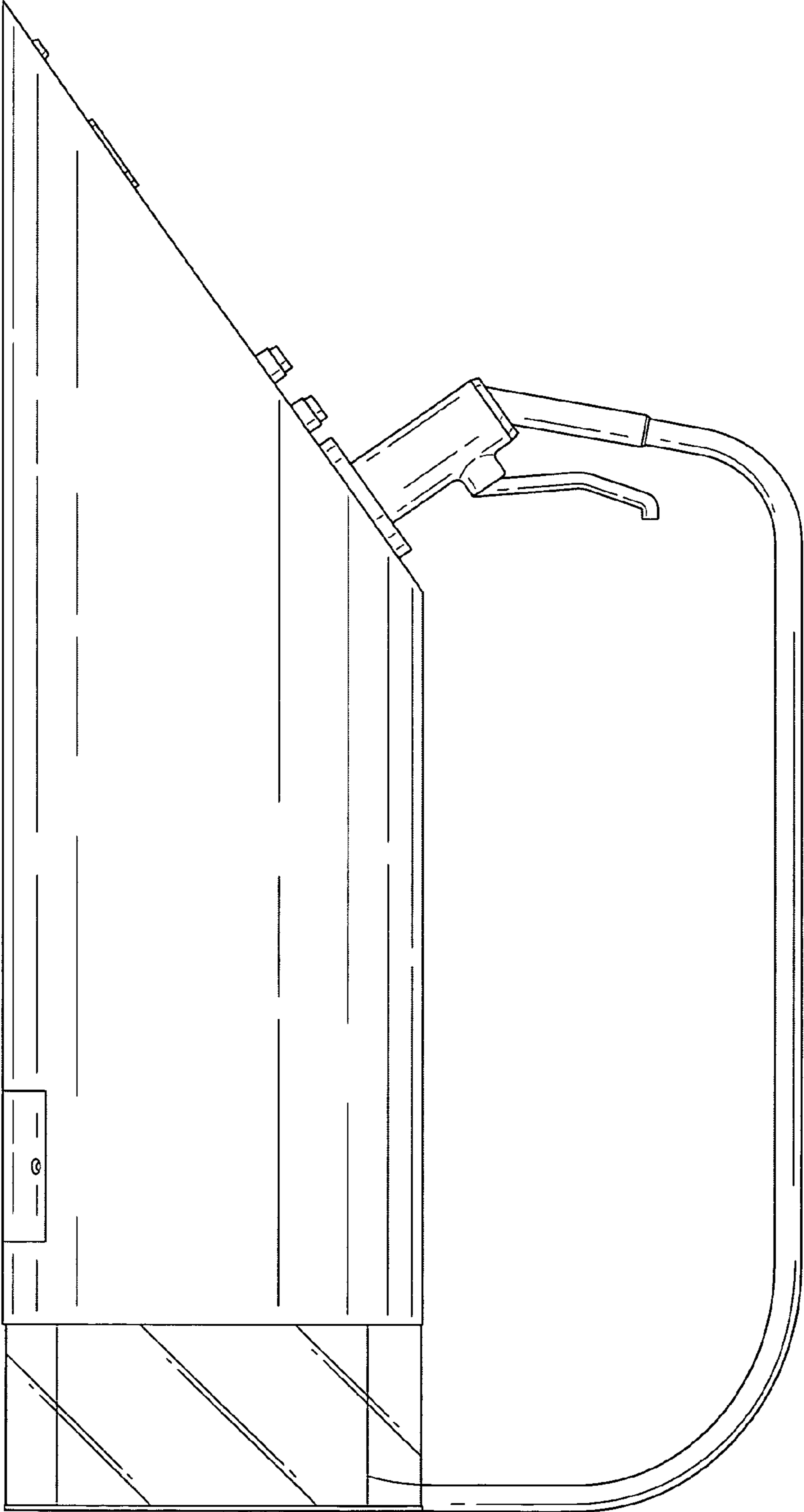

FIG. 4

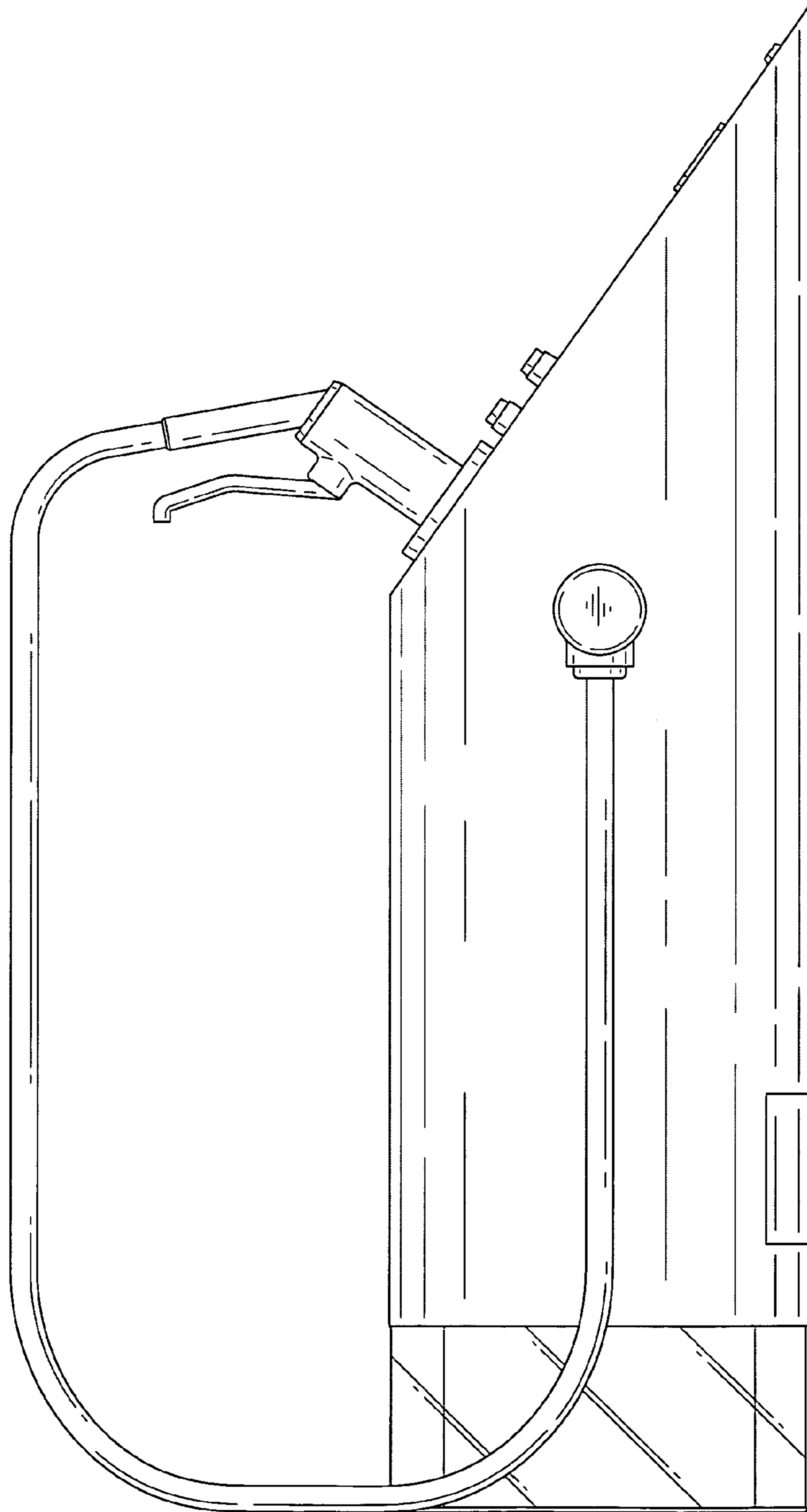
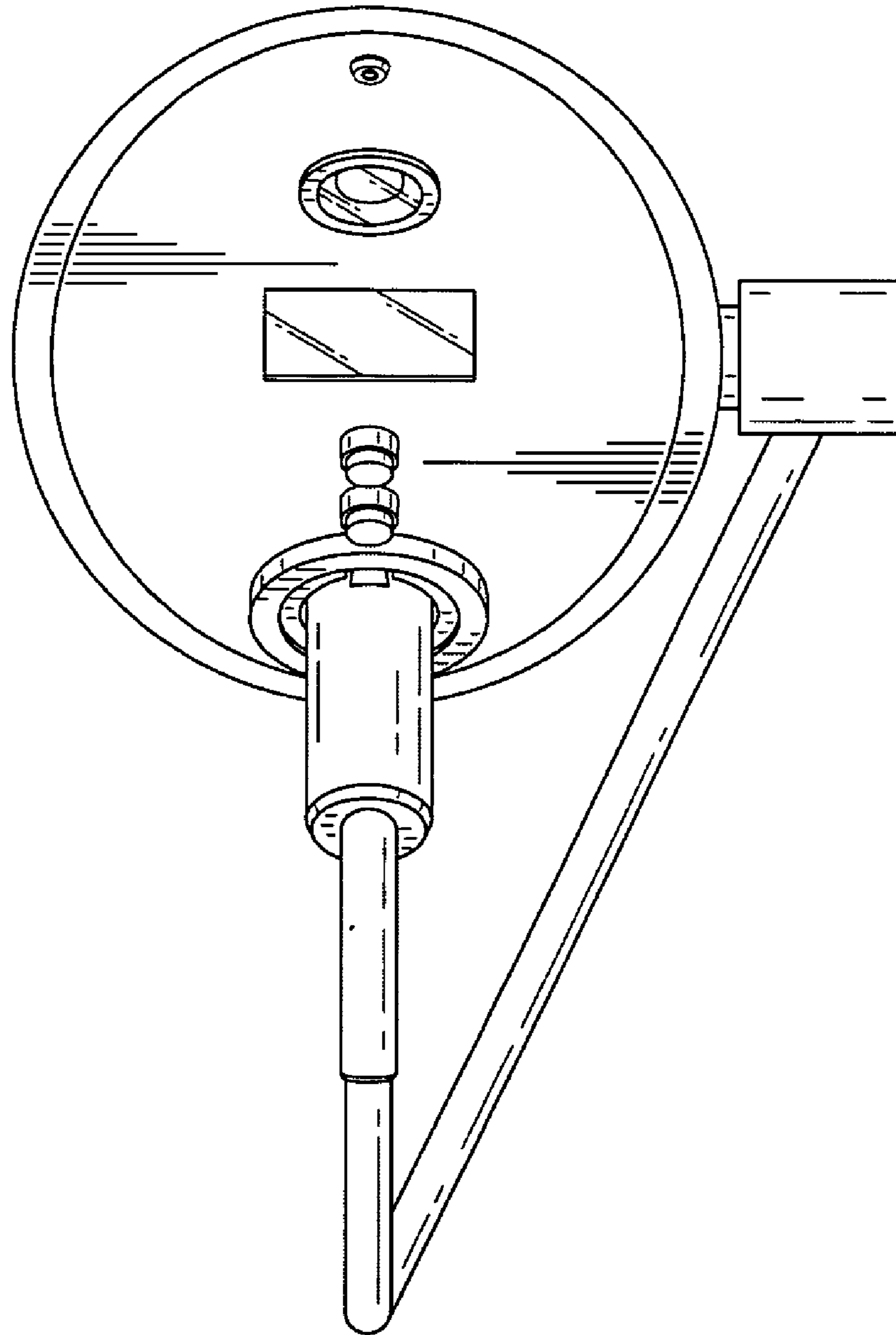
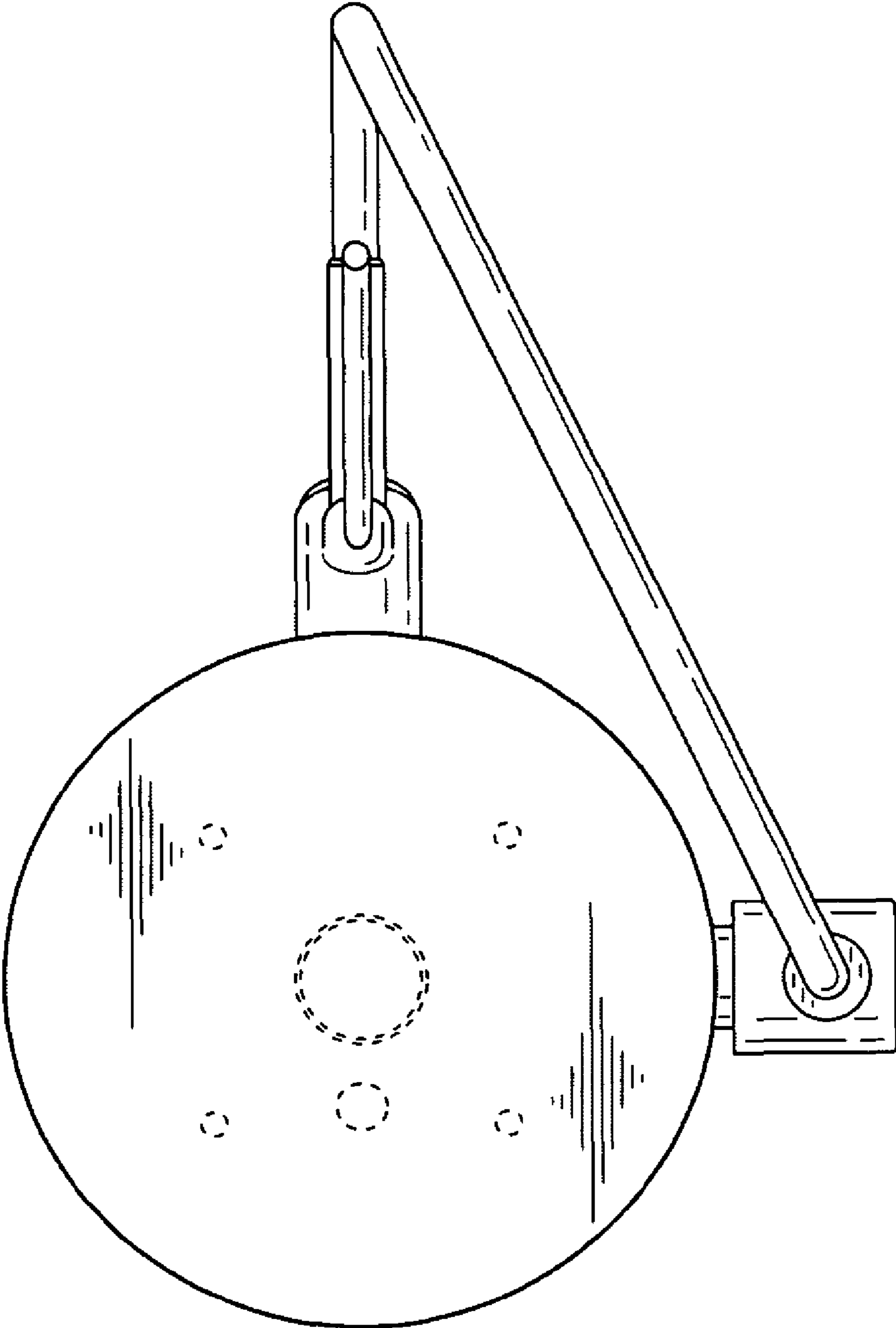

FIG. 5





**FIG. 6**



**FIG. 7**



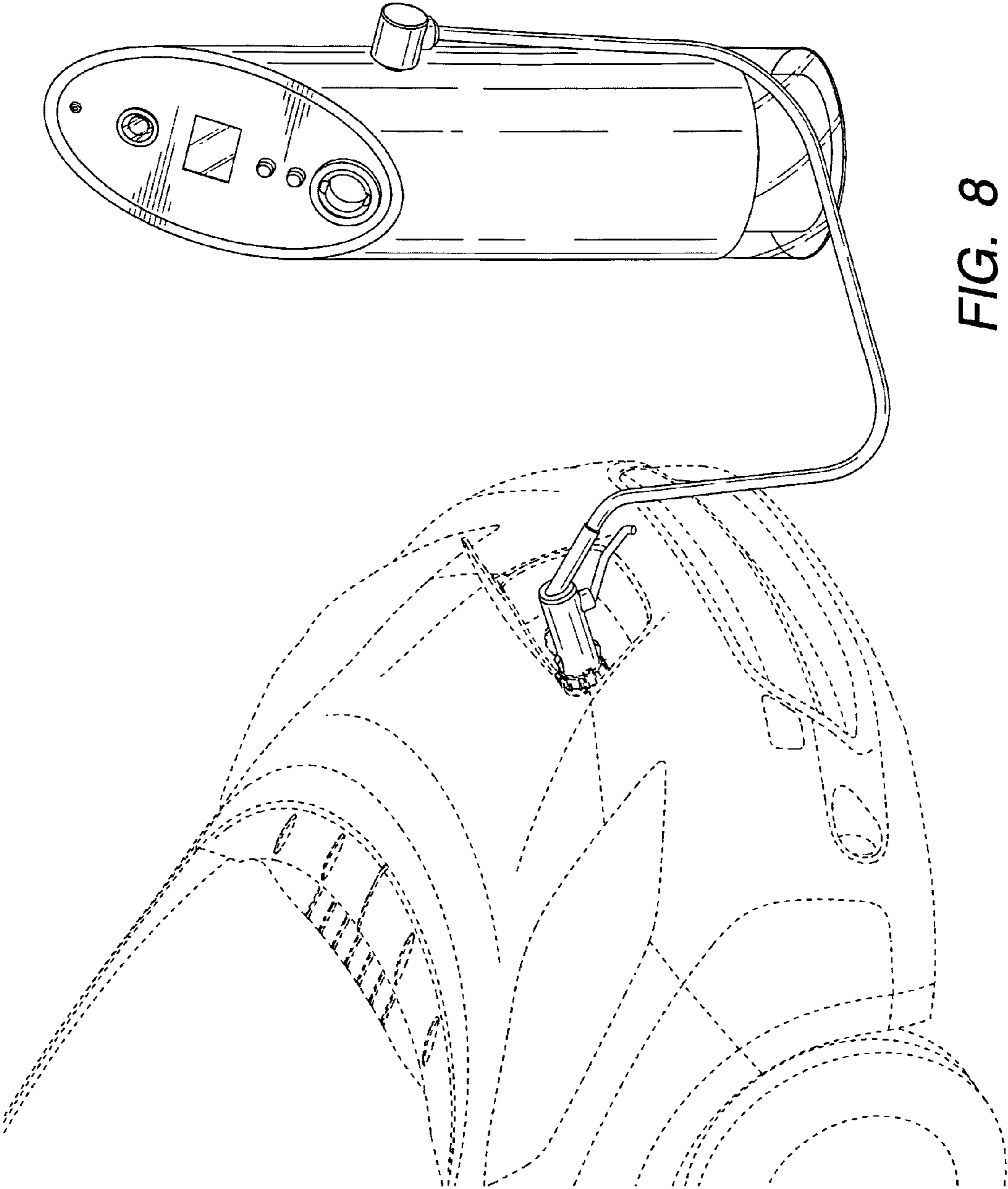

FIG. 8