



US00D628520S

(12) **United States Design Patent**  
**Lin**

(10) **Patent No.:** **US D628,520 S**

(45) **Date of Patent:** **\*\* Dec. 7, 2010**

(54) **ALL TERRAIN VEHICLE**

D542,186 S \* 5/2007 Lai et al. .... D12/107  
D584,661 S \* 1/2009 Tanaka et al. .... D12/107

(75) Inventor: **Xuegang Lin**, Chongqing (CN)

\* cited by examiner

(73) Assignee: **Loncin Industry Co., Ltd.**, Chongqing (CN)

*Primary Examiner*—Philip S Hyder  
*Assistant Examiner*—Linda G. Brooks

(\*\*) Term: **14 Years**

(74) *Attorney, Agent, or Firm*—Vincent K. Gustafson;  
Intellectual Property Technology Law

(21) Appl. No.: **29/335,751**

(57) **CLAIM**

(22) Filed: **Apr. 21, 2009**

The ornamental design for an all terrain vehicle, as shown and described.

(51) **LOC (9) Cl.** ..... **12-11**

(52) **U.S. Cl.** ..... **D12/107**

(58) **Field of Classification Search** ..... D12/3,  
D12/86, 87, 107, 110; 180/225, 223, 233,  
180/229, 311, 312, 315

See application file for complete search history.

**DESCRIPTION**

FIG. 1 is a perspective view of an all terrain vehicle showing my new design;

FIG. 2 is a right side elevation view thereof;

FIG. 3 is a left side elevation view thereof;

FIG. 4 is a top plan view thereof;

FIG. 5 is a front elevation view thereof; and,

FIG. 6 is a rear elevation view thereof.

All structures indicated in broken lines are not part of the all terrain vehicle design sought to be patented, and form no part of the claimed design.

(56) **References Cited**

**U.S. PATENT DOCUMENTS**

|          |   |   |         |                  |       |         |
|----------|---|---|---------|------------------|-------|---------|
| D427,110 | S | * | 6/2000  | Saito et al.     | ..... | D12/107 |
| D428,363 | S | * | 7/2000  | Sugimoto et al.  | ..... | D12/107 |
| D429,663 | S | * | 8/2000  | Tamashima et al. | ..... | D12/107 |
| D436,559 | S | * | 1/2001  | Fujieda          | ..... | D12/107 |
| D516,467 | S | * | 3/2006  | Wu               | ..... | D12/107 |
| D520,912 | S | * | 5/2006  | Knight et al.    | ..... | D12/107 |
| D529,414 | S | * | 10/2006 | Wu et al.        | ..... | D12/107 |

**1 Claim, 6 Drawing Sheets**

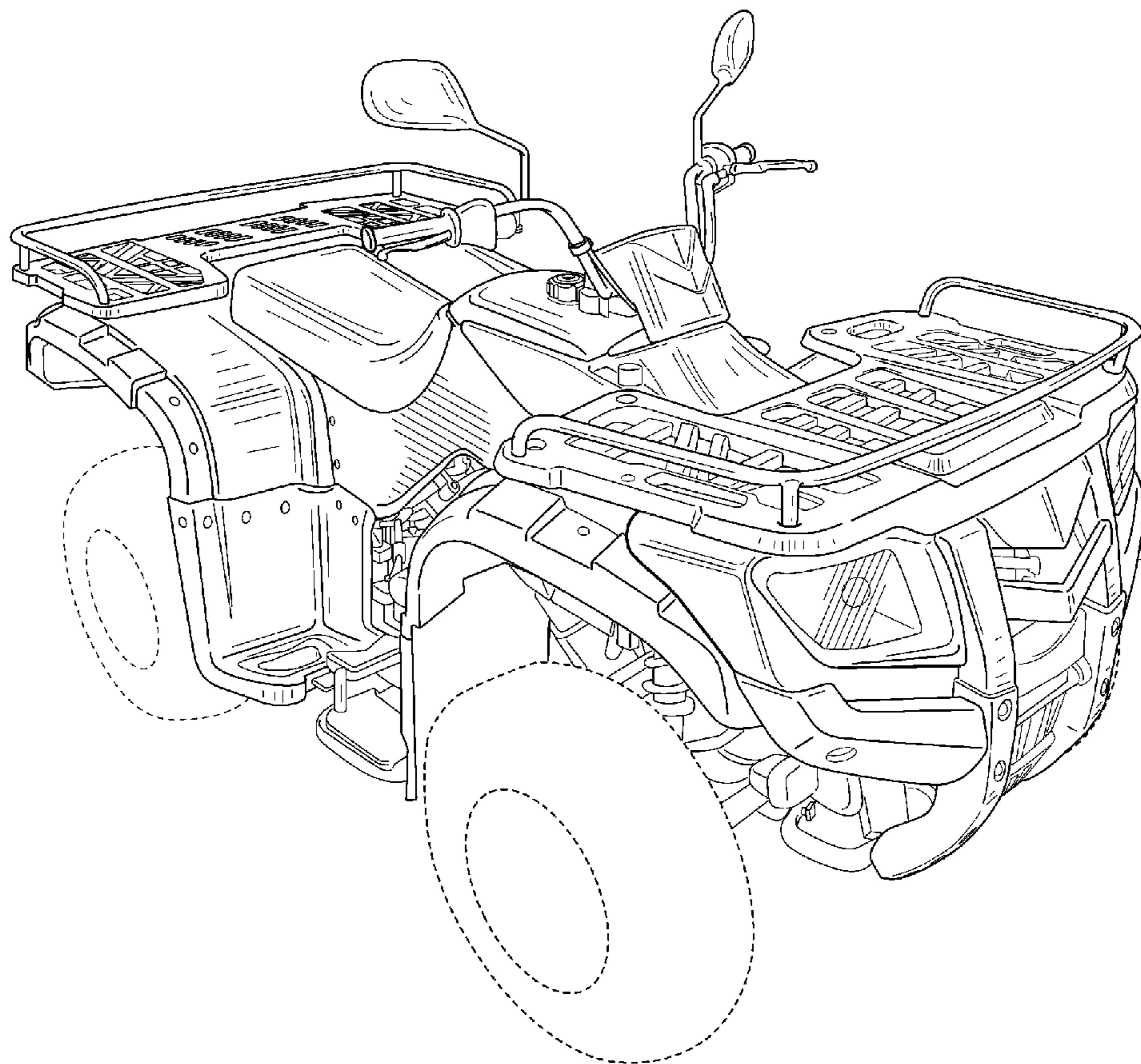

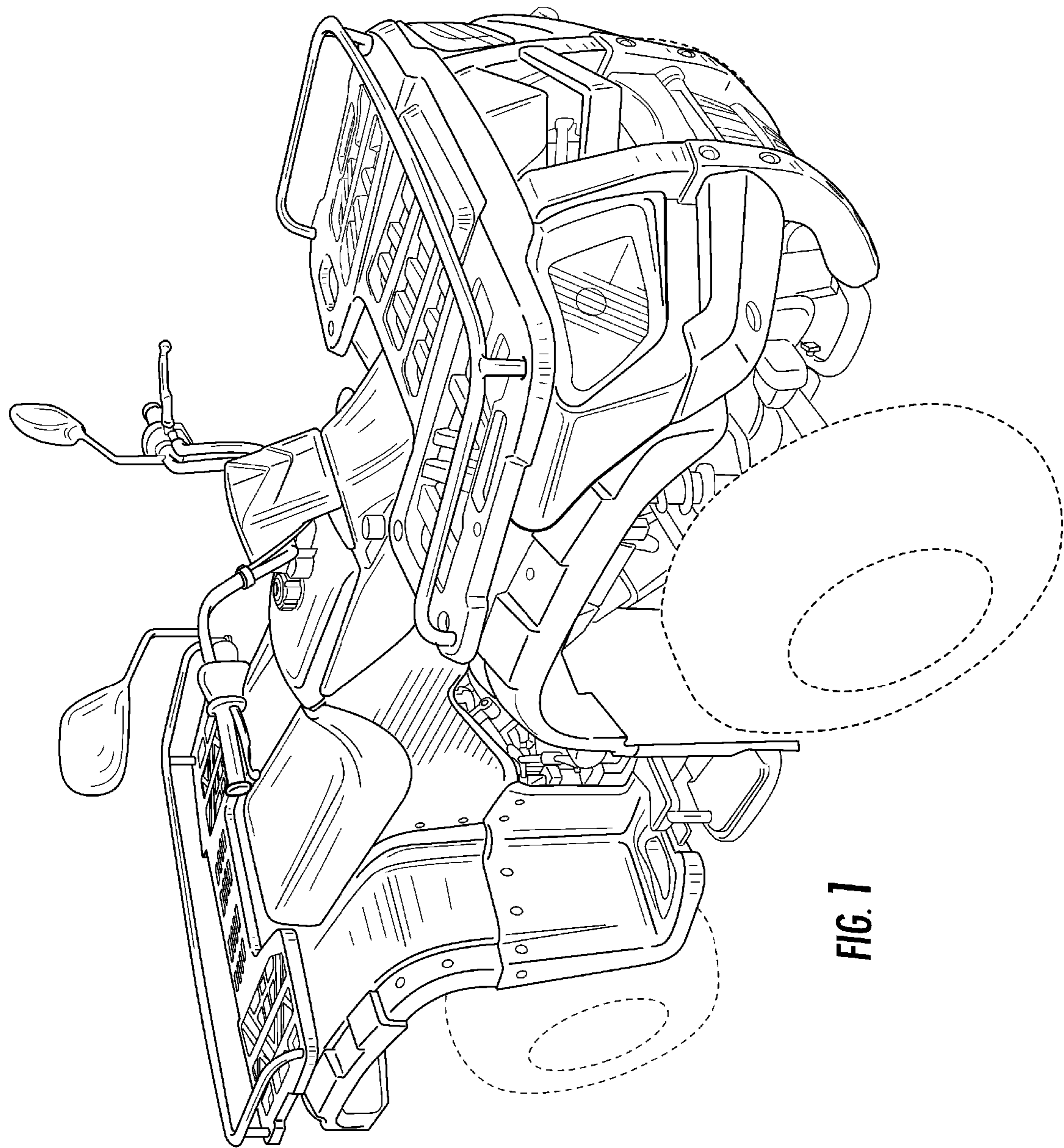

FIG. 1

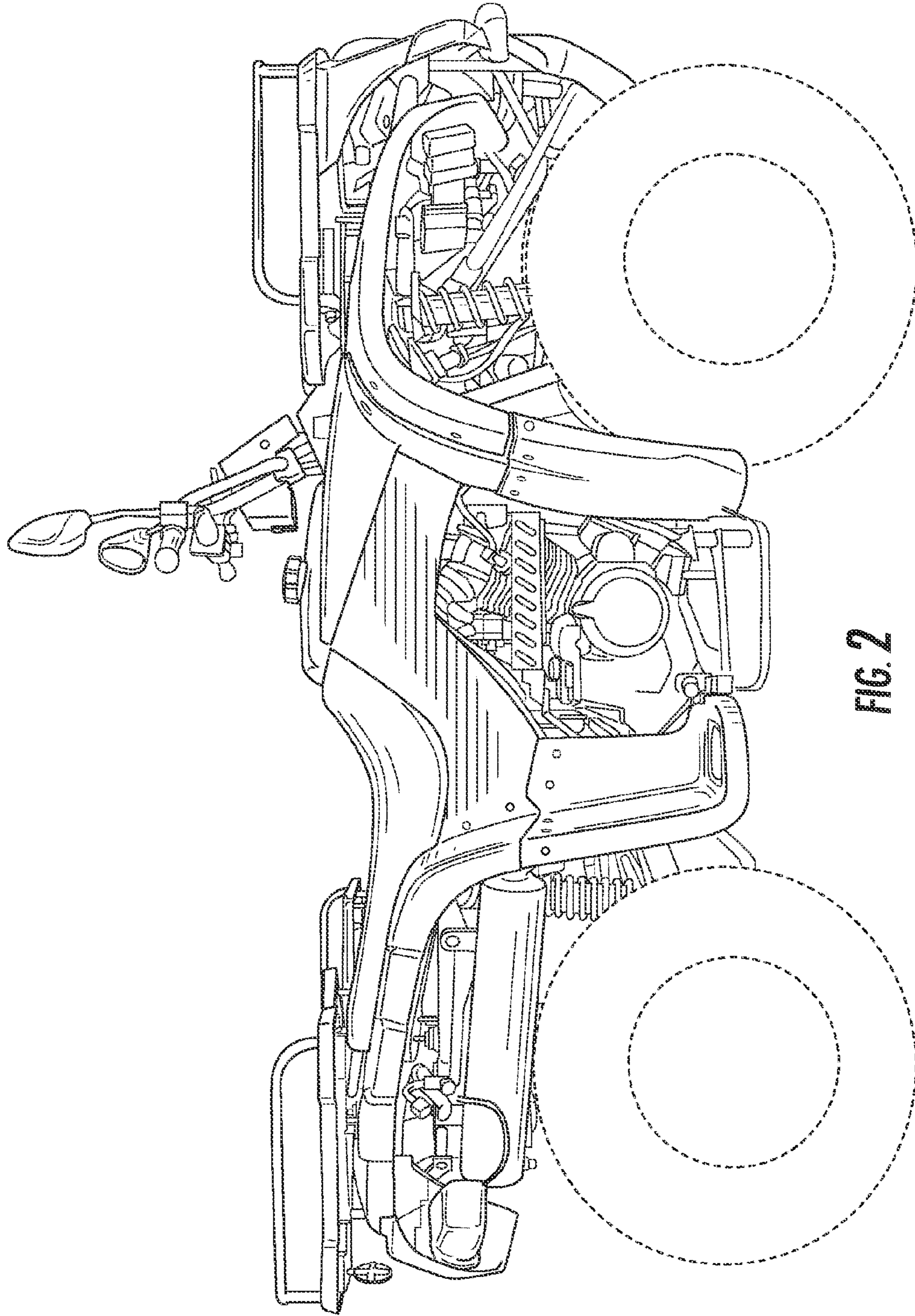

FIG. 2

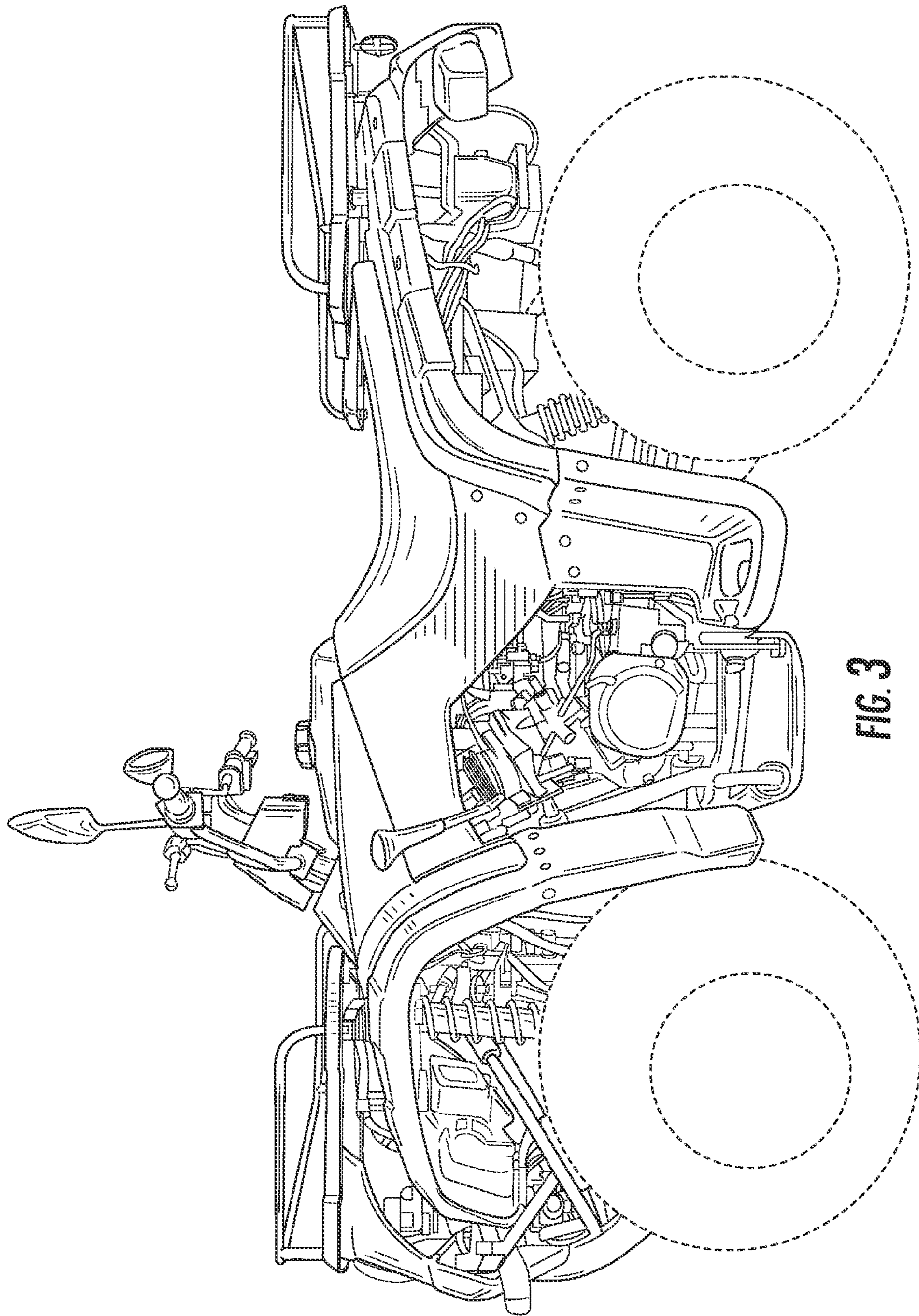

FIG. 3

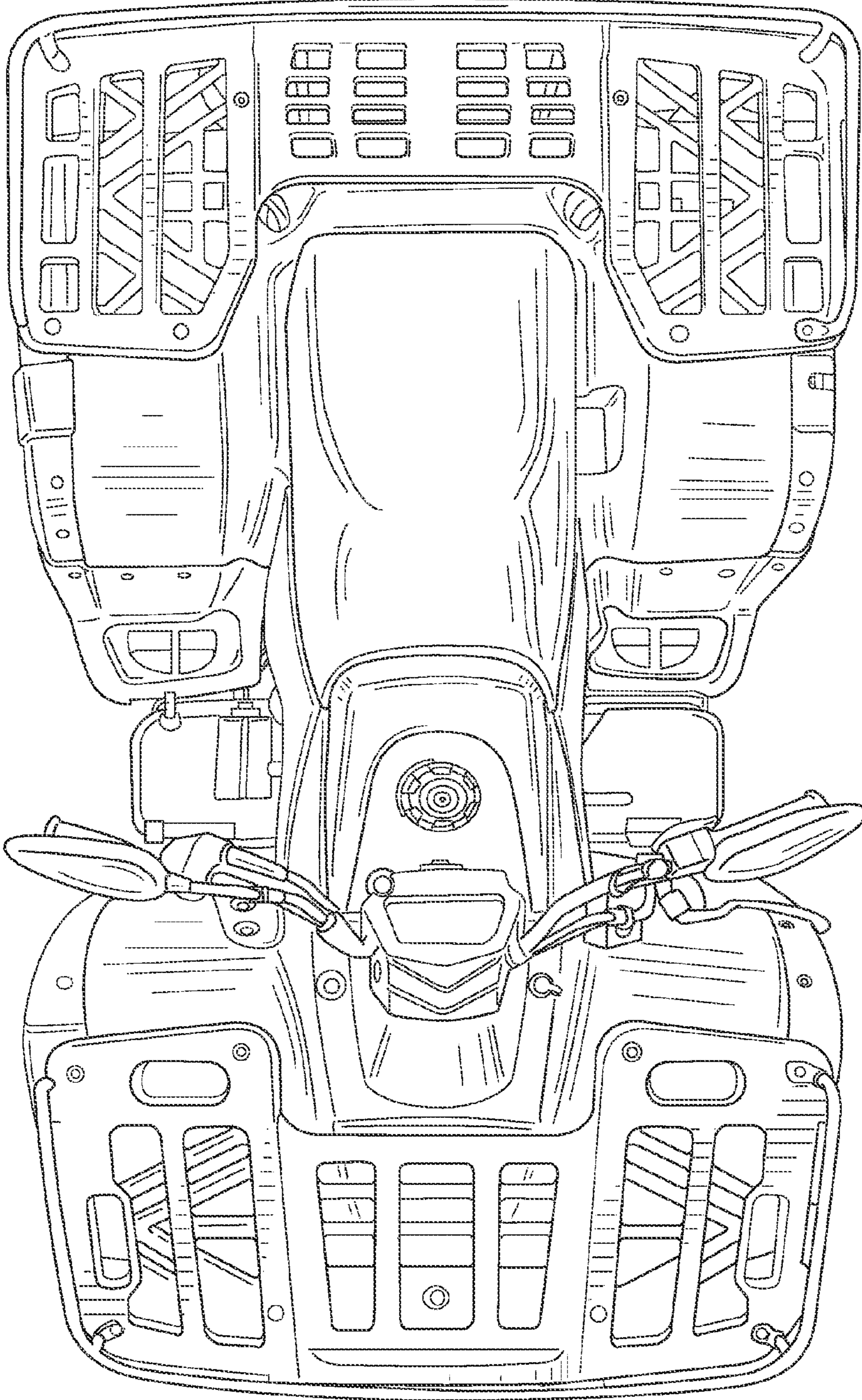
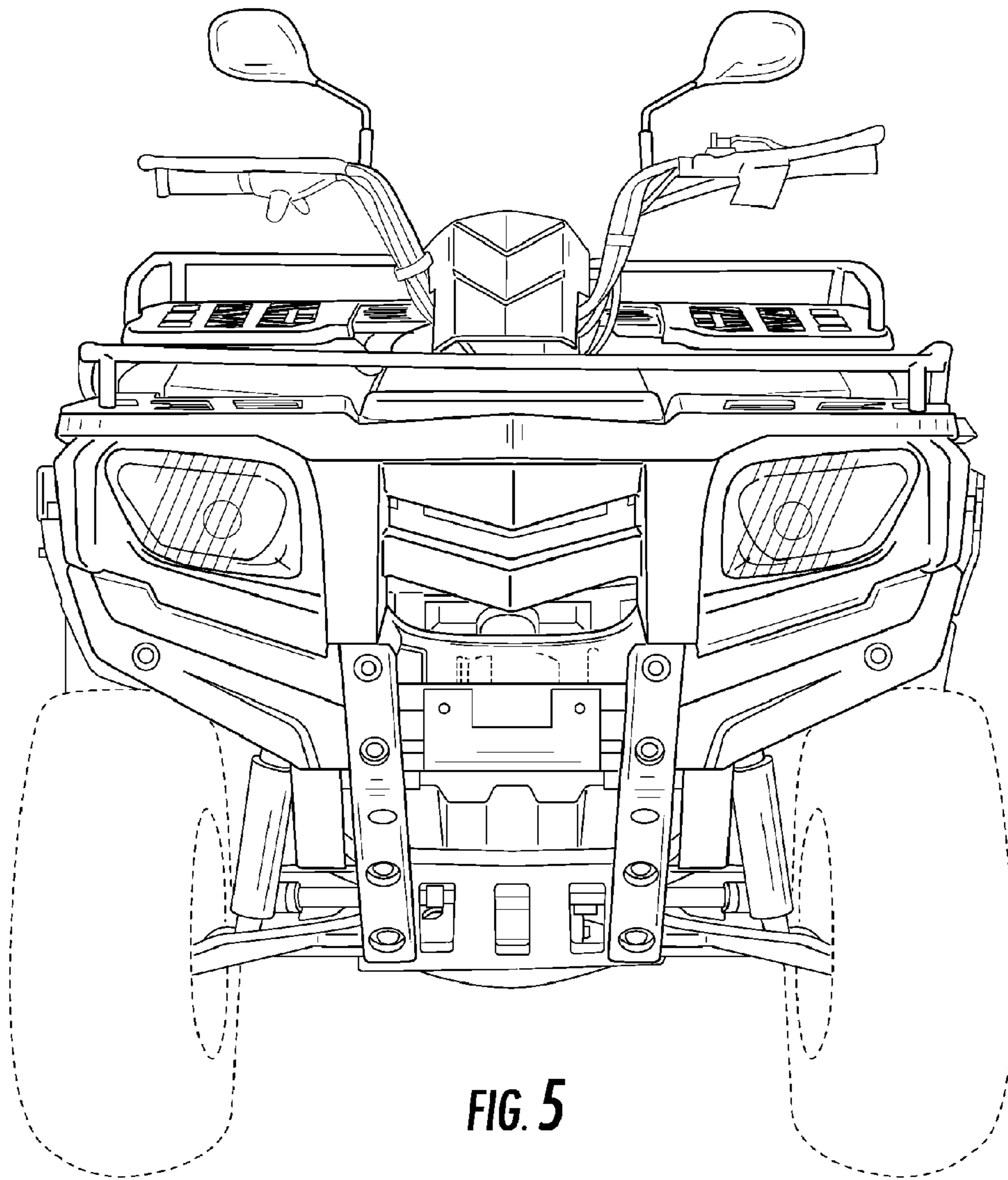

FIG. 4



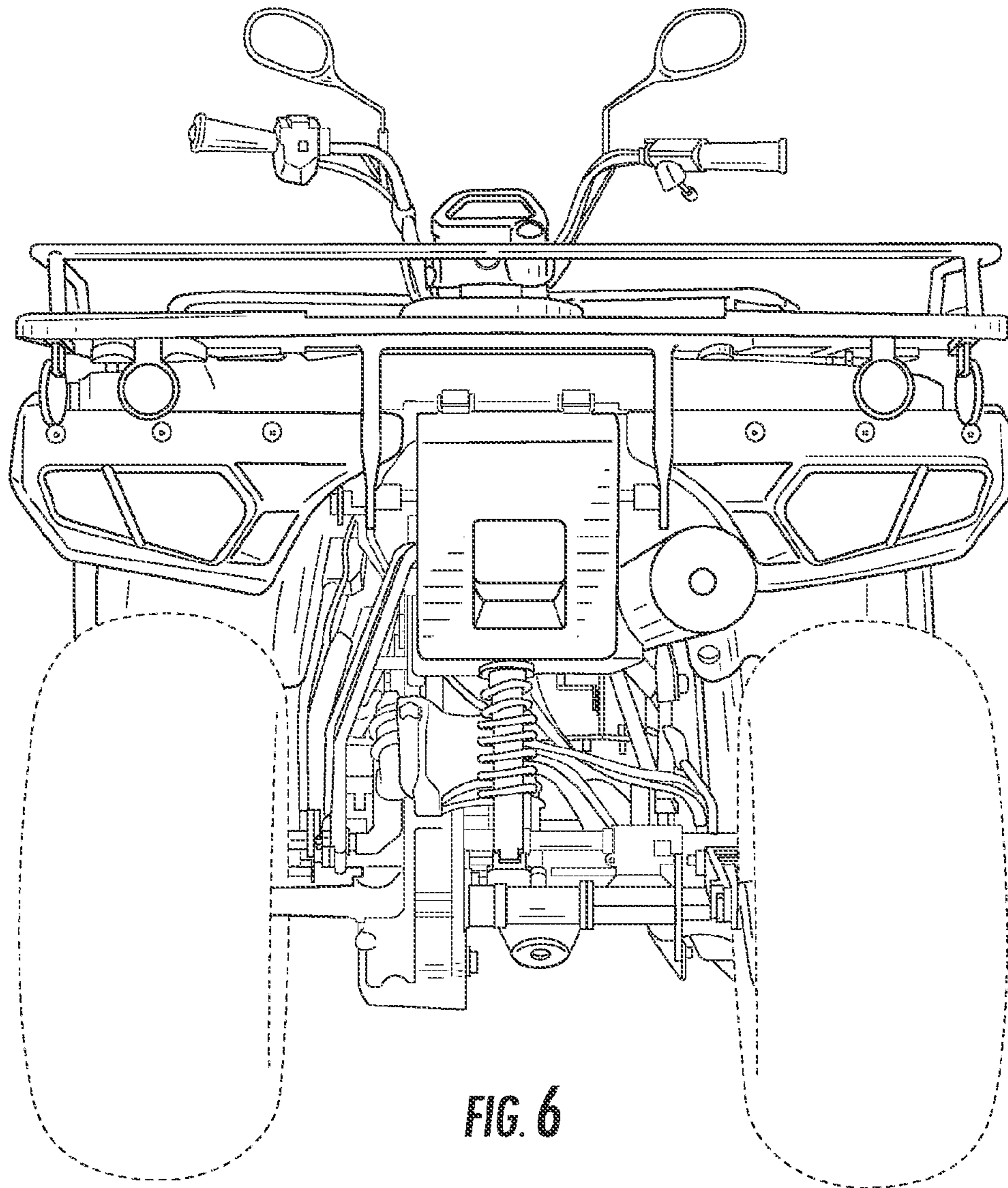

FIG. 6