



US00D628454S

(12) **United States Design Patent**
Misaki

(10) **Patent No.:** **US D628,454 S**

(45) **Date of Patent:** **** Dec. 7, 2010**

(54) **PORTABLE ELECTRIC DRILL**

(75) Inventor: **Shingo Misaki**, Anjo (JP)

(73) Assignee: **Makita Corporation**, Anjo-Shi (JP)

(**) Term: **14 Years**

(21) Appl. No.: **29/356,268**

(22) Filed: **Feb. 23, 2010**

(30) **Foreign Application Priority Data**

Sep. 4, 2009 (JP) 2009-20440

(51) **LOC (9) Cl.** **08-04**

(52) **U.S. Cl.** **D8/68**

(58) **Field of Classification Search** D8/14.1,
D8/61, 62, 63, 64, 65, 66, 67, 68, 69, 70;
81/57.11, 429, 454, 455, 456, 469, 489; 173/13,
173/104, 114, 168, 169, 170, 171, 178, 201,
173/211, 213, 217; 408/20, 124, 125, 234,
408/241 R; 451/358; 310/50; 227/8, 113,
227/114, 120, 130, 136, 142

See application file for complete search history.

(56) **References Cited**

U.S. PATENT DOCUMENTS

D513,951 S * 1/2006 Chung et al. D8/68

D587,545 S 3/2009 Hayakawa et al.

D588,429 S * 3/2009 Misaki et al. D8/68

D588,430 S * 3/2009 Misaki D8/68

D609,543 S * 2/2010 Misaki et al. D8/68

* cited by examiner

Primary Examiner—Antoine D Davis

(74) *Attorney, Agent, or Firm*—Oliff & Berridge, PLC

(57) **CLAIM**

The ornamental design for a portable electric drill, as shown and described.

DESCRIPTION

FIG. 1 is a perspective view of a portable electric drill showing our new design;

FIG. 2 is a front elevation view thereof;

FIG. 3 is a rear elevation view thereof;

FIG. 4 is a left side elevation view thereof;

FIG. 5 is a right side elevation view thereof;

FIG. 6 is a top plan view thereof; and,

FIG. 7 is a bottom plan view thereof.

1 Claim, 5 Drawing Sheets

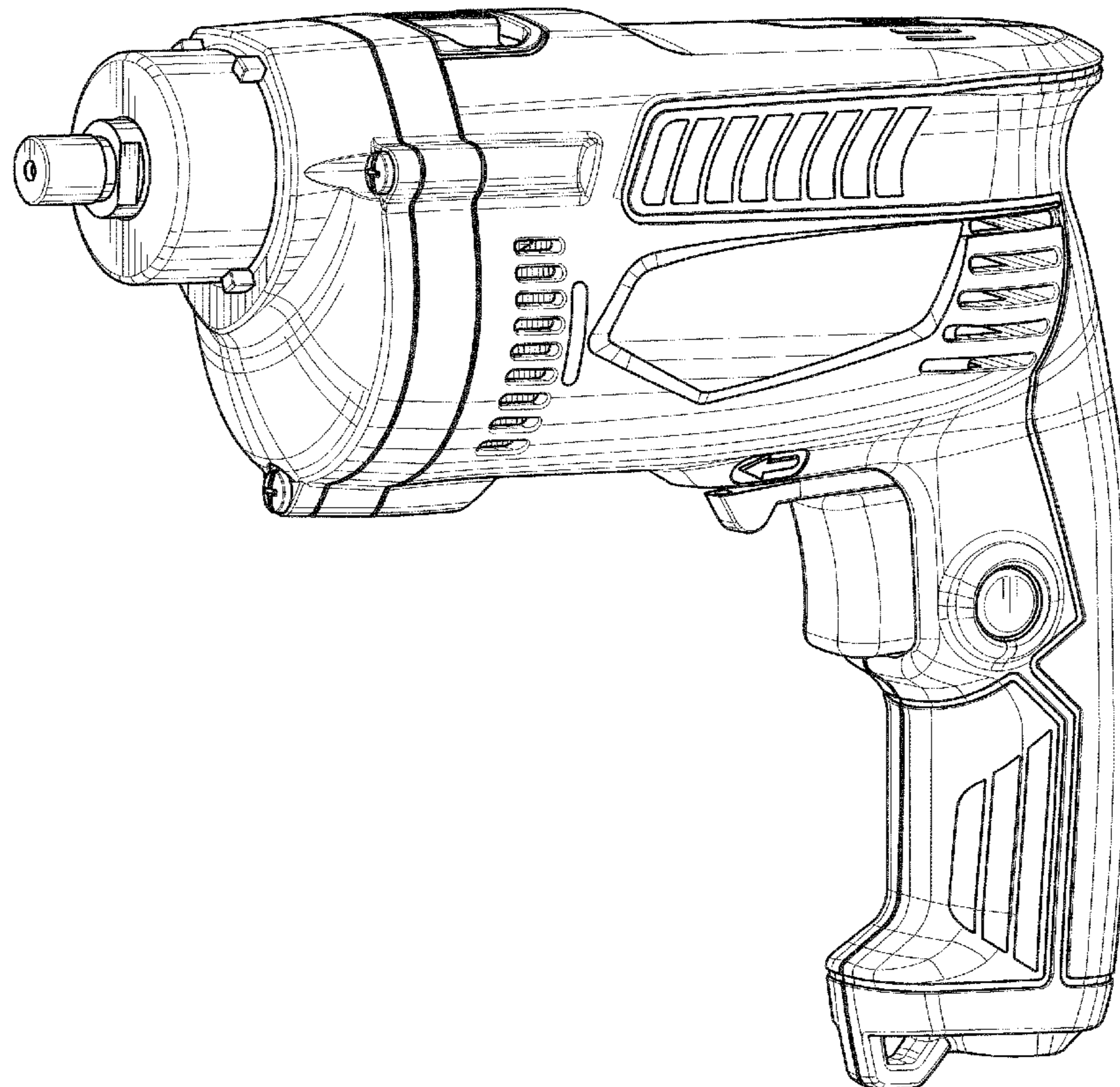

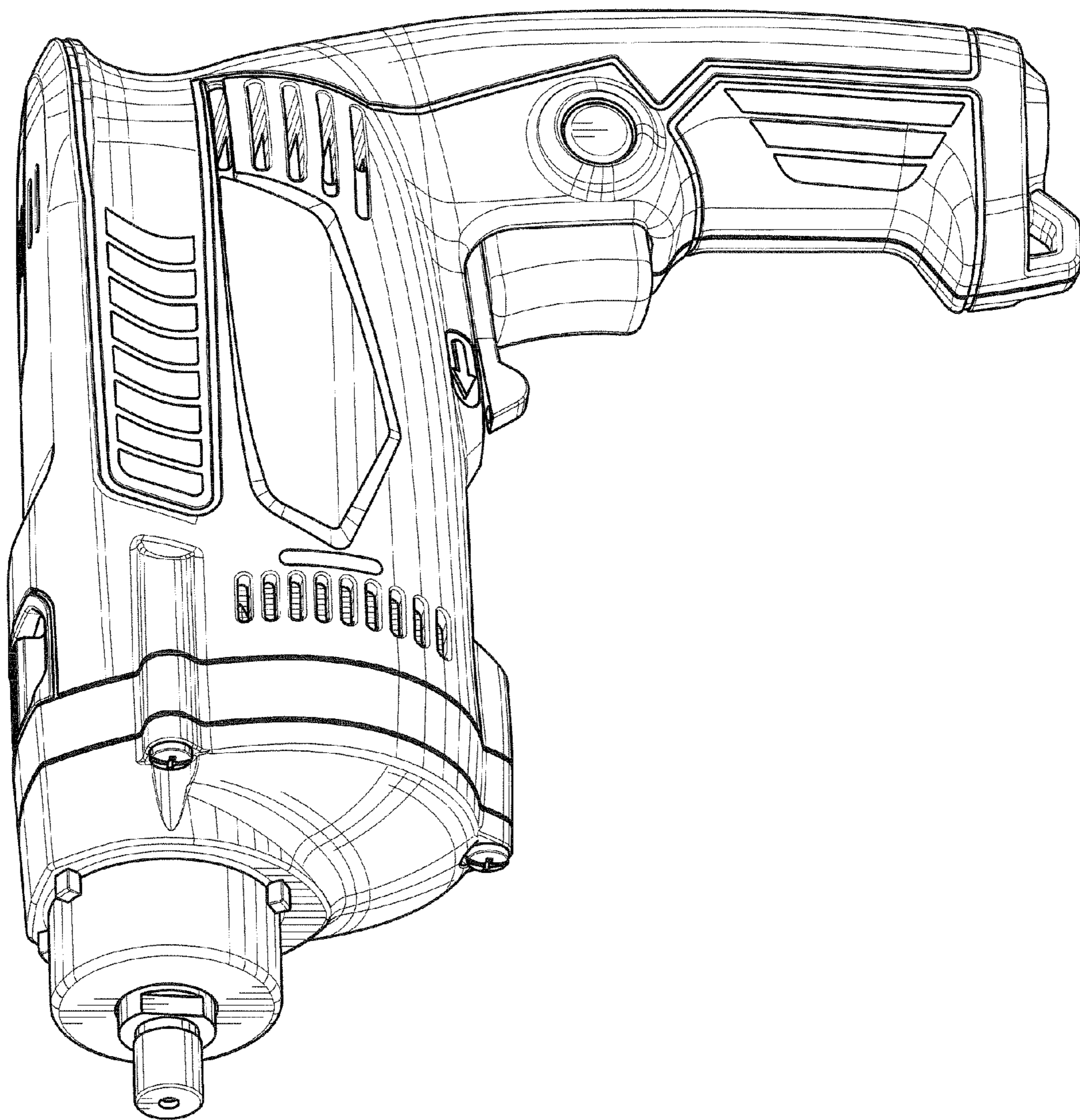

FIG. 1

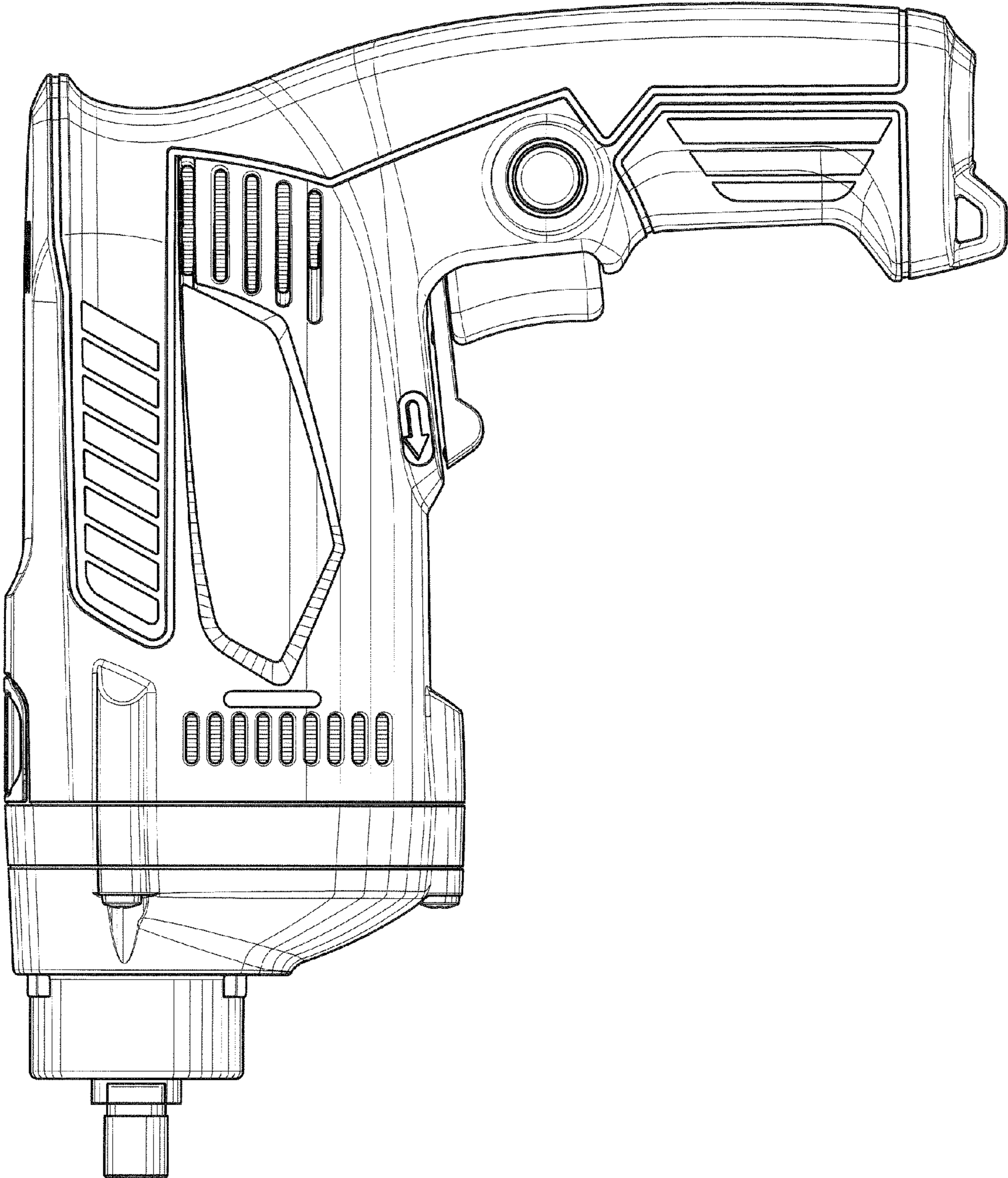

FIG. 2

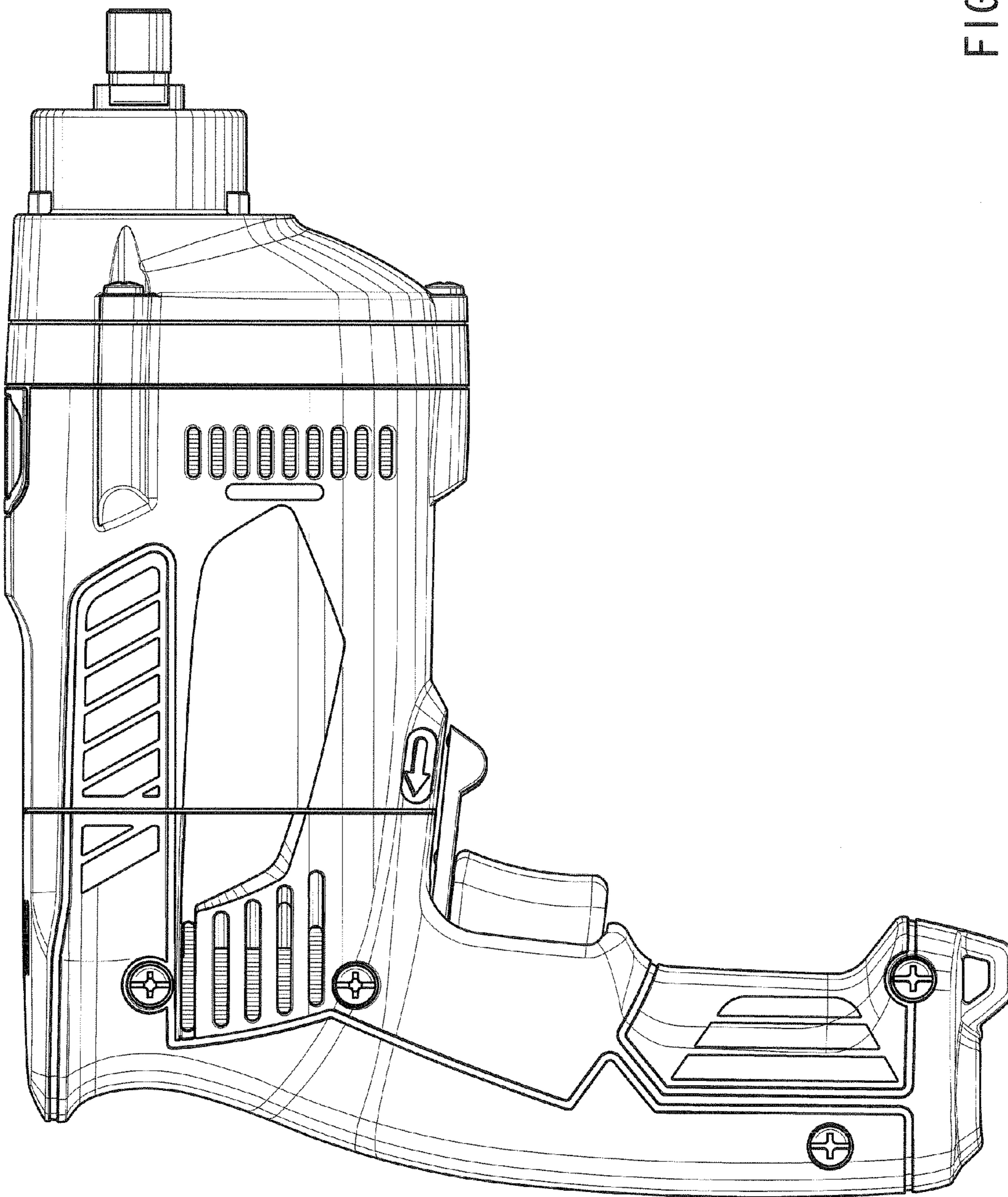

FIG. 3

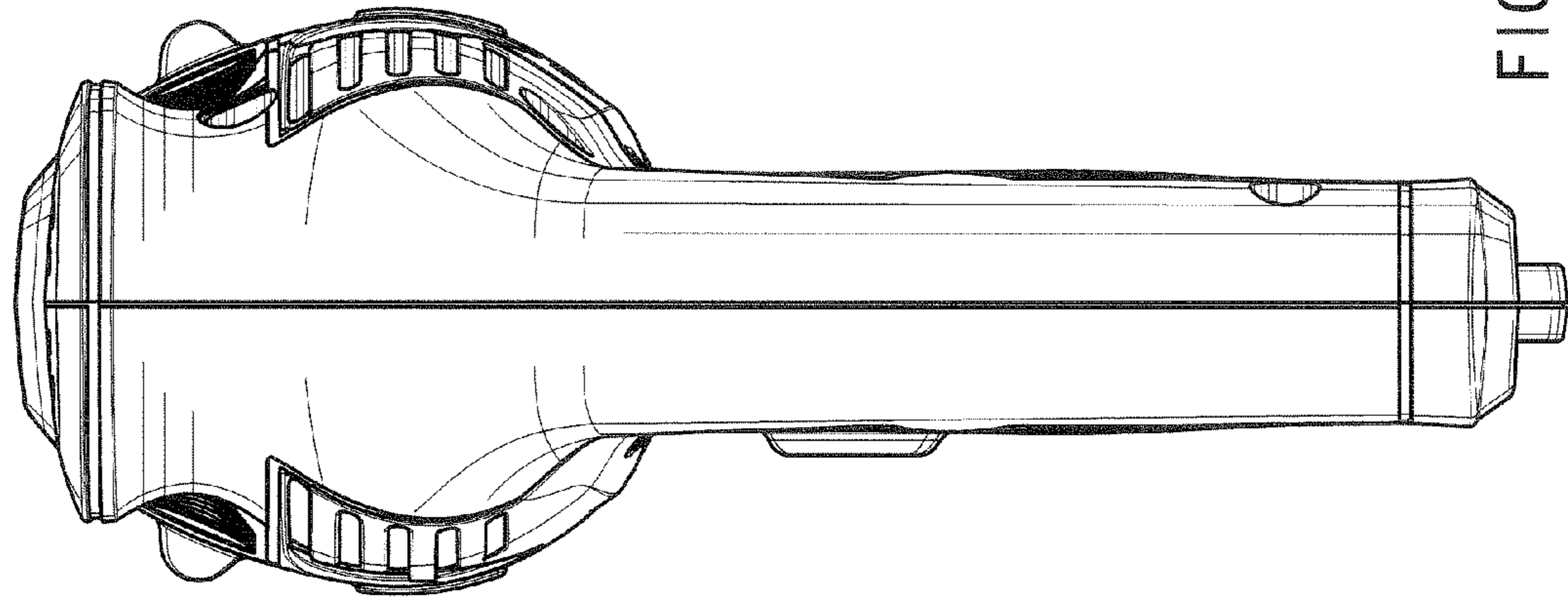

FIG. 5

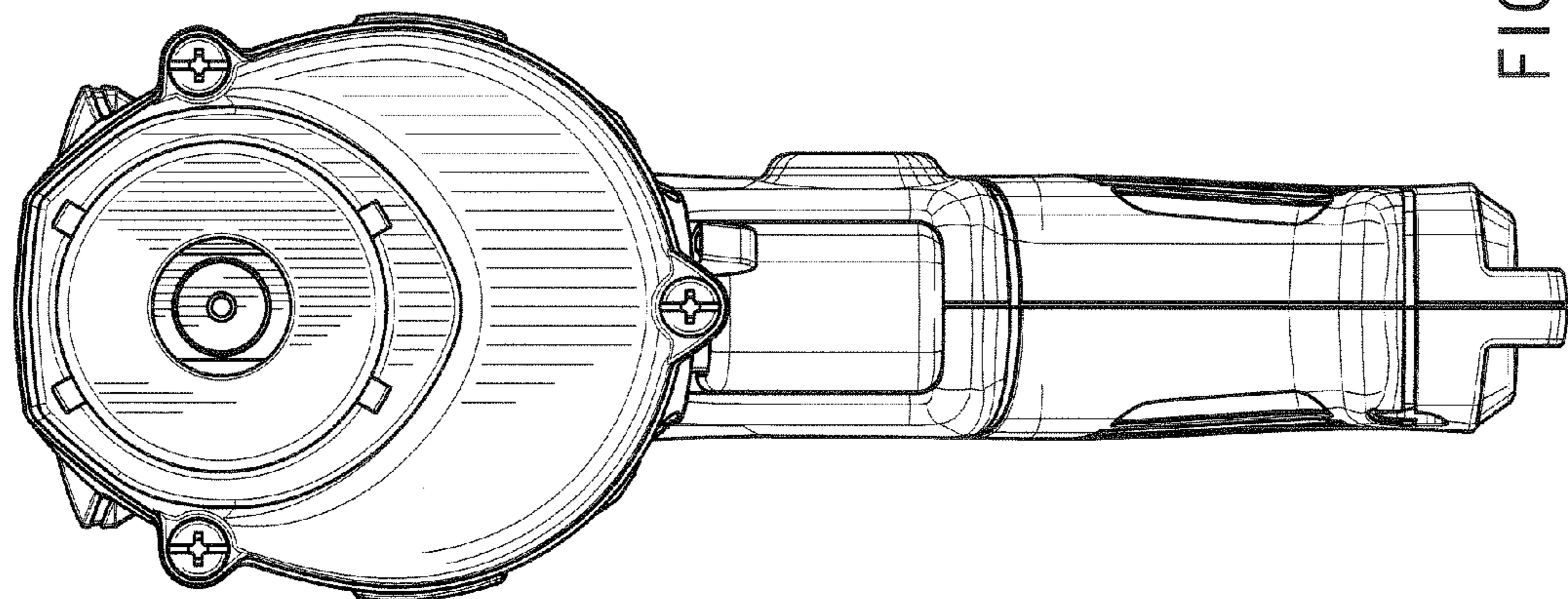

FIG. 4

FIG. 6

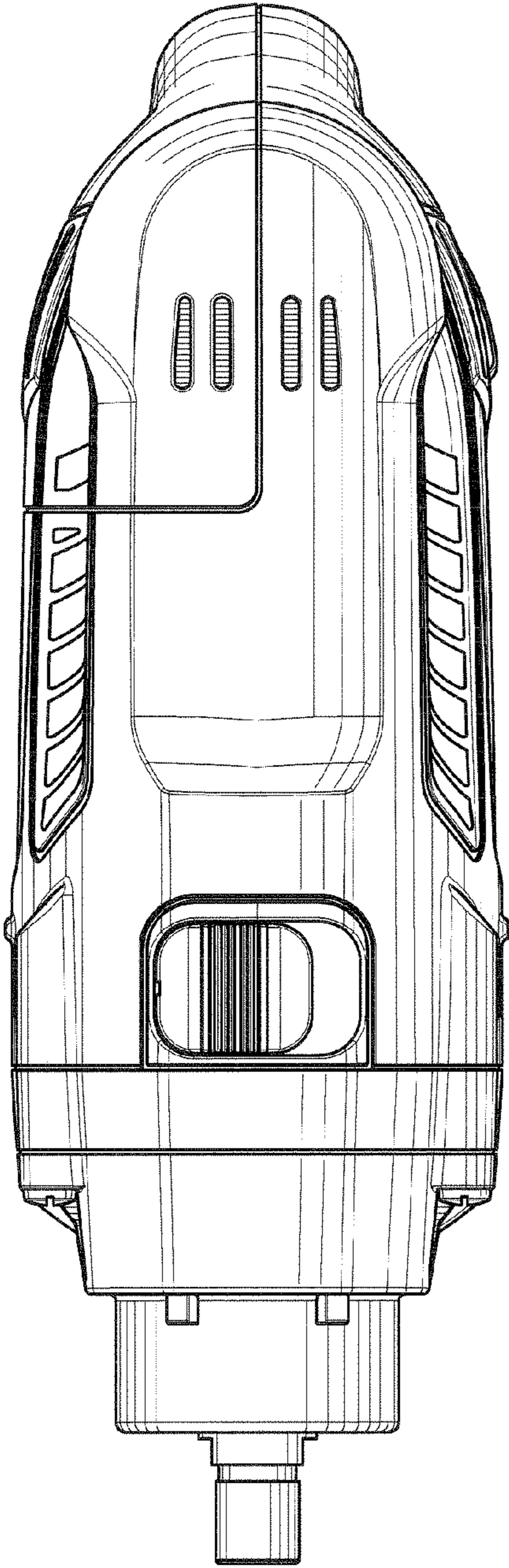

FIG. 7

