



US00D628138S

(12) **United States Design Patent**  
**Collins et al.**

(10) **Patent No.:** **US D628,138 S**  
(45) **Date of Patent:** **\*\* Nov. 30, 2010**

(54) **AIRCRAFT CABIN STRUCTURE**

**DESCRIPTION**

(75) Inventors: **Mark Collins**, Geneva (CH); **Alexandra Collins**, Geneva (CH)

(73) Assignee: **Airbus SAS**, Blagnac Cedex (FR)

(\*\*) Term: **14 Years**

(21) Appl. No.: **29/278,460**

(22) Filed: **Mar. 30, 2007**

(51) **LOC (9) Cl.** ..... **12-07**

(52) **U.S. Cl.** ..... **D12/345**

(58) **Field of Classification Search** ..... D6/356,  
D6/357, 332, 491, 381, 448; 244/118.6;  
D14/308, 140.2; D12/183, 345, 195, 192,  
D12/415; D13/184, 163; D25/58; 297/343  
See application file for complete search history.

(56) **References Cited**

**U.S. PATENT DOCUMENTS**

2,092,655 A \* 9/1937 Page, Jr. .... 244/118.6  
2,504,645 A \* 4/1950 Burnett ..... 297/67

(Continued)

**FOREIGN PATENT DOCUMENTS**

WO 2002/080196 9/2005

**OTHER PUBLICATIONS**

U.S. Appl. No. 29/278,457. Title: Aircraft Cabin Accessories, filed Mar. 30, 2007.

(Continued)

*Primary Examiner*—Cathron C Brooks

*Assistant Examiner*—Kevin K Rudzinski

(74) *Attorney, Agent, or Firm*—Osler, Hoskin & Harcourt LLP

(57) **CLAIM**

The ornamental design for an aircraft cabin structure, as shown and described.

FIG. 1 is a top, right perspective view showing an aircraft cabin structure according to an embodiment of our design shown with cabin elements in broken lines;

FIG. 2 is a left side elevation view of the aircraft cabin structure of FIG. 1 shown with the cabin elements removed;

FIG. 3 is a top plan view thereof;

FIG. 4 is a section view thereof, taken along line 4—4 in FIG. 3;

FIG. 5 is a section view thereof, taken along line 5—5 in FIG. 3;

FIG. 6 is a section view thereof, taken along line 6—6 in FIG. 3;

FIG. 7 is a section view thereof, taken along line 7—7 in FIG. 3;

FIG. 8 is a top, right perspective view showing an aircraft cabin structure according to another embodiment of our design shown with cabin elements in broken lines;

FIG. 9 is a left side elevation view of the aircraft cabin structure of FIG. 8 shown with the cabin elements removed;

FIG. 10 is a top plan view thereof;

FIG. 11 is a section view thereof, taken along line 11—11 in FIG. 10;

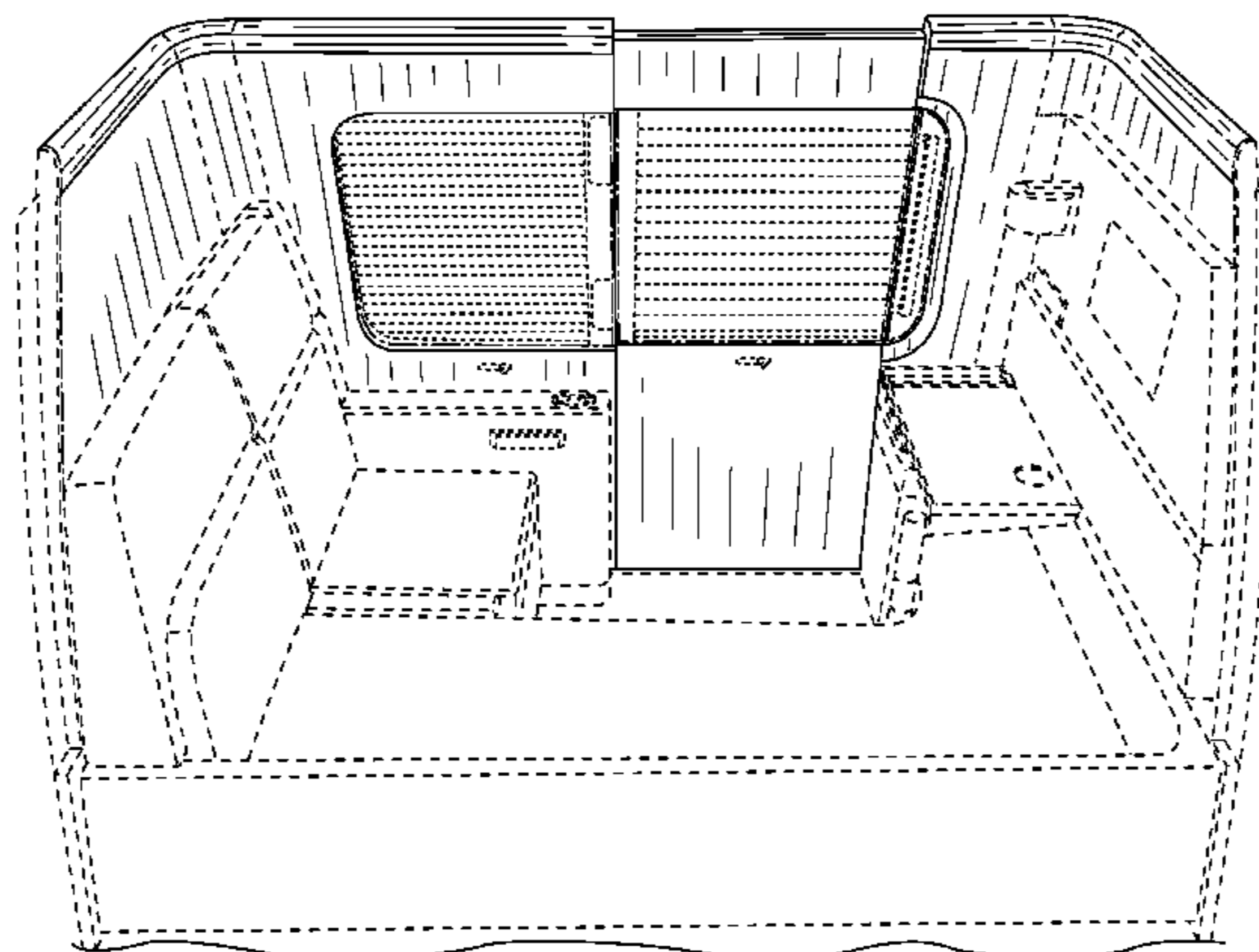
FIG. 12 is a section view thereof, taken along line 12—12 in FIG. 10;

FIG. 13 is a section view thereof, taken along line 13—13 in FIG. 10; and,

FIG. 14 is a section view thereof, taken along line 14—14 in FIG. 10.

Throughout the Figures, broken lines showing environment or structure are for illustrative purposes only and form no part of the claimed design. Unshaded surfaces do not form part of the claimed design. Dash-dot broken lines represent the boundary between claimed and unclaimed areas and form no part of the claimed design.

**1 Claim, 14 Drawing Sheets**



# US D628,138 S

Page 2

---

## U.S. PATENT DOCUMENTS

2,983,230 A \* 5/1961 Murphy ..... 105/315  
4,018,166 A \* 4/1977 Gutridge et al. .... 105/316  
4,679,610 A \* 7/1987 Spraggins ..... 160/107  
D331,215 S \* 11/1992 Moreno et al. .... D12/183  
D409,010 S 5/1999 Papaioannou et al.  
6,056,239 A \* 5/2000 Cantu et al. .... 244/118.6  
D439,425 S 3/2001 Park et al.  
D443,990 S 6/2001 Beroth

D487,981 S 4/2004 Ludeke et al.  
D510,816 S 10/2005 Lee

## OTHER PUBLICATIONS

U.S. Appl. No. 29/278,461. Title: Aircraft Cabin Seating Area, And Cabin Arrangement, filed Mar. 30, 2007.  
U.S. Appl. No. 29/278,458. Title: Aircraft Seat, filed Mar. 30, 2007.

\* cited by examiner

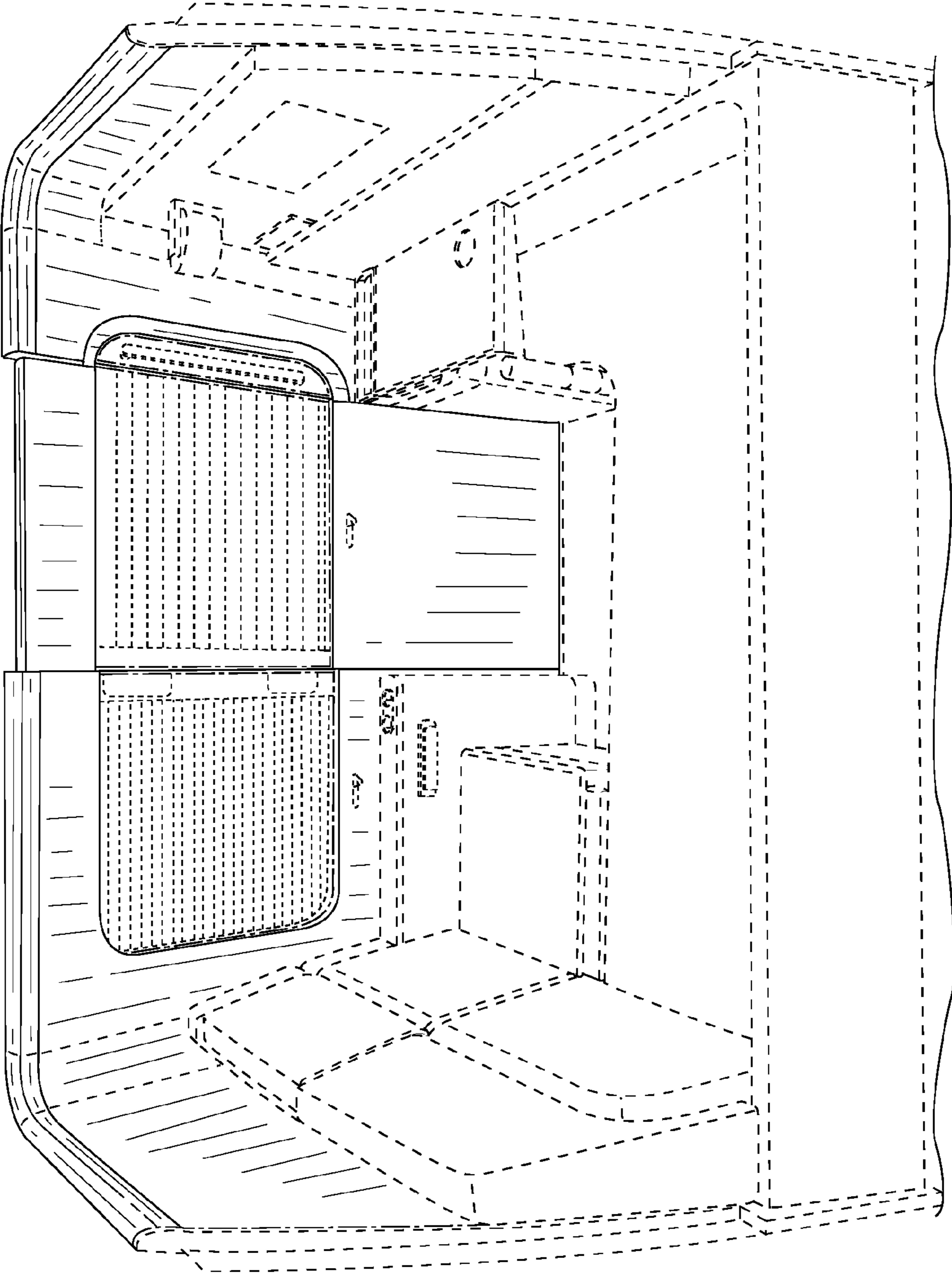
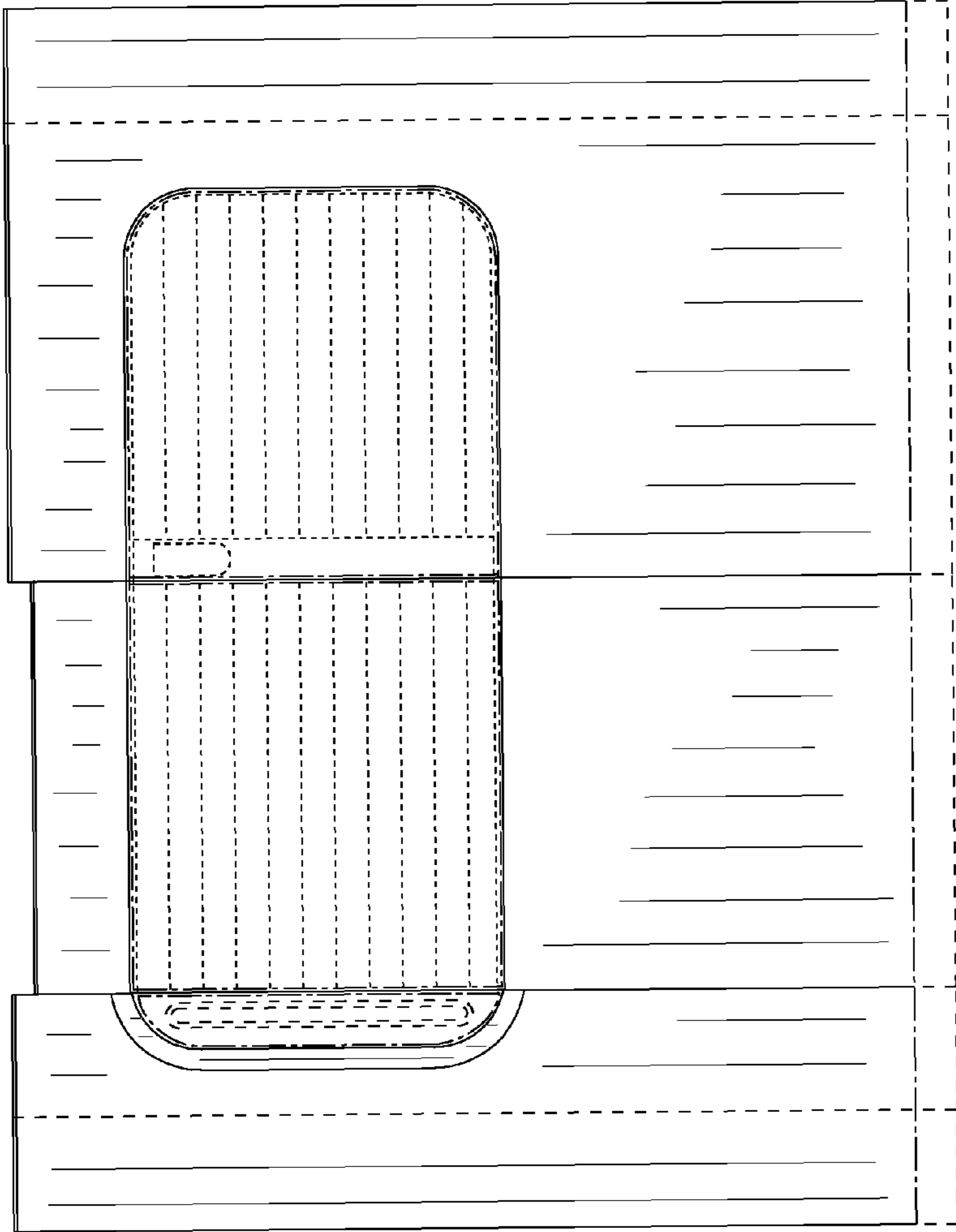
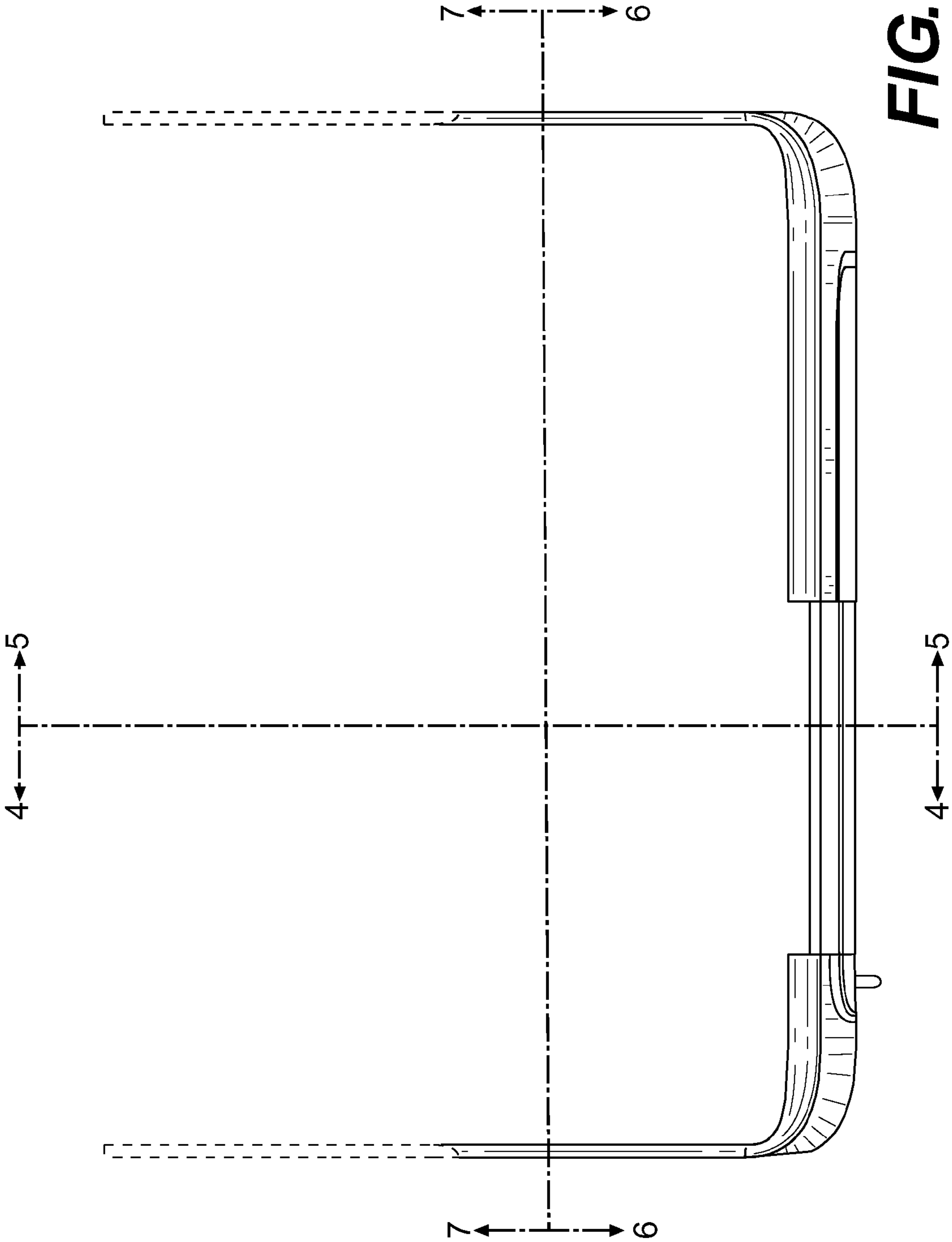


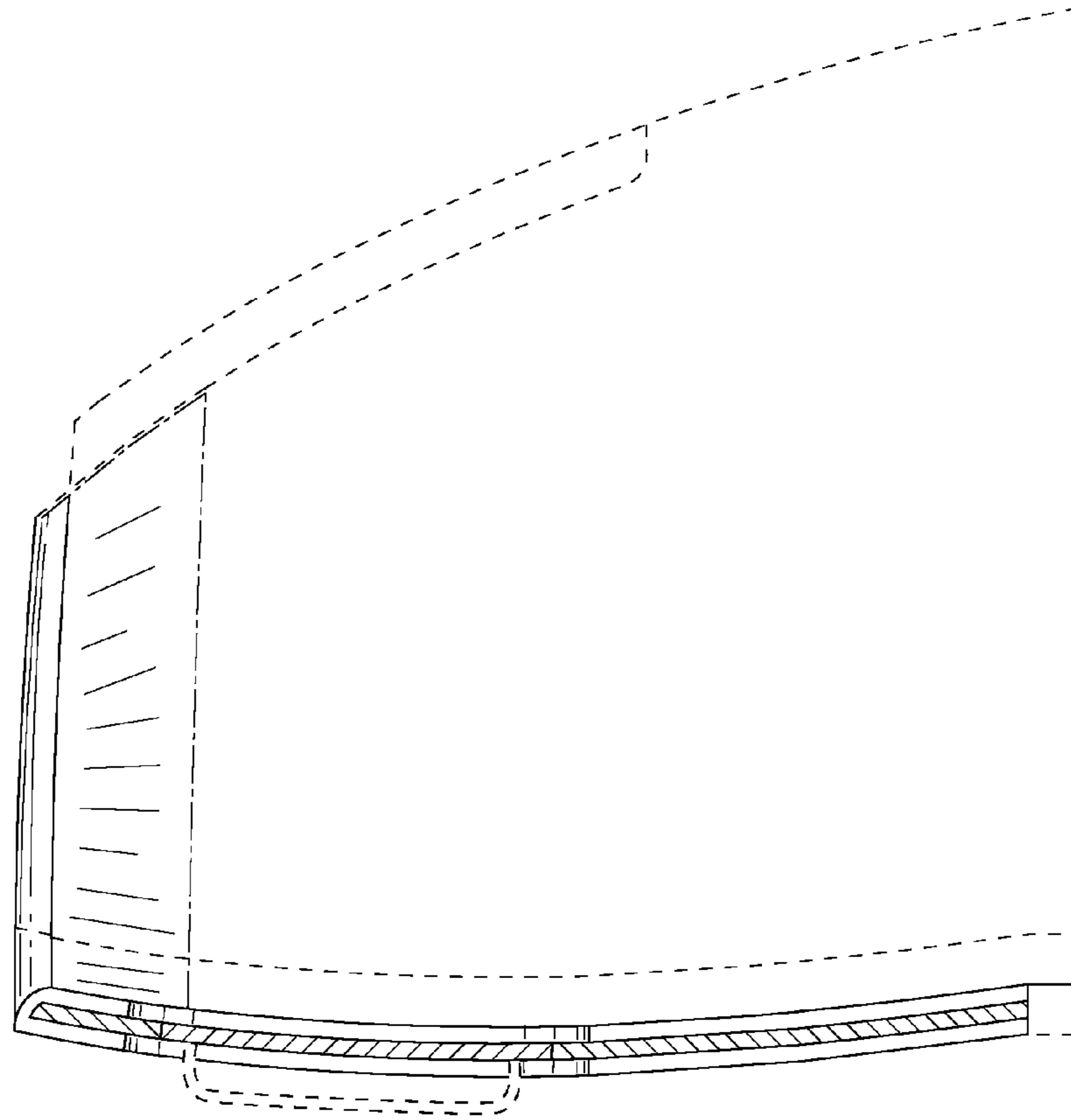
FIG. 1



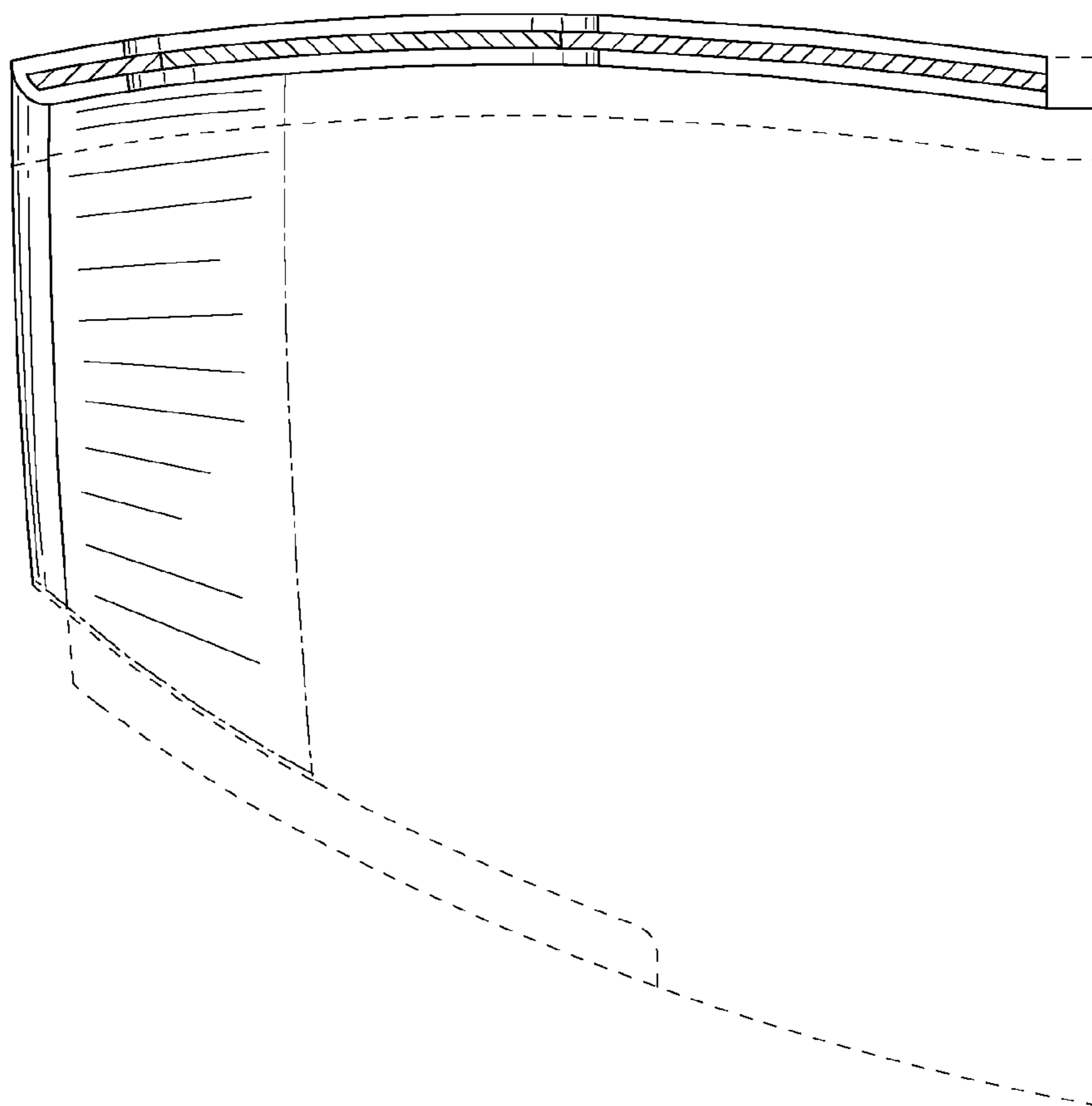
**FIG. 2**



**FIG. 3**

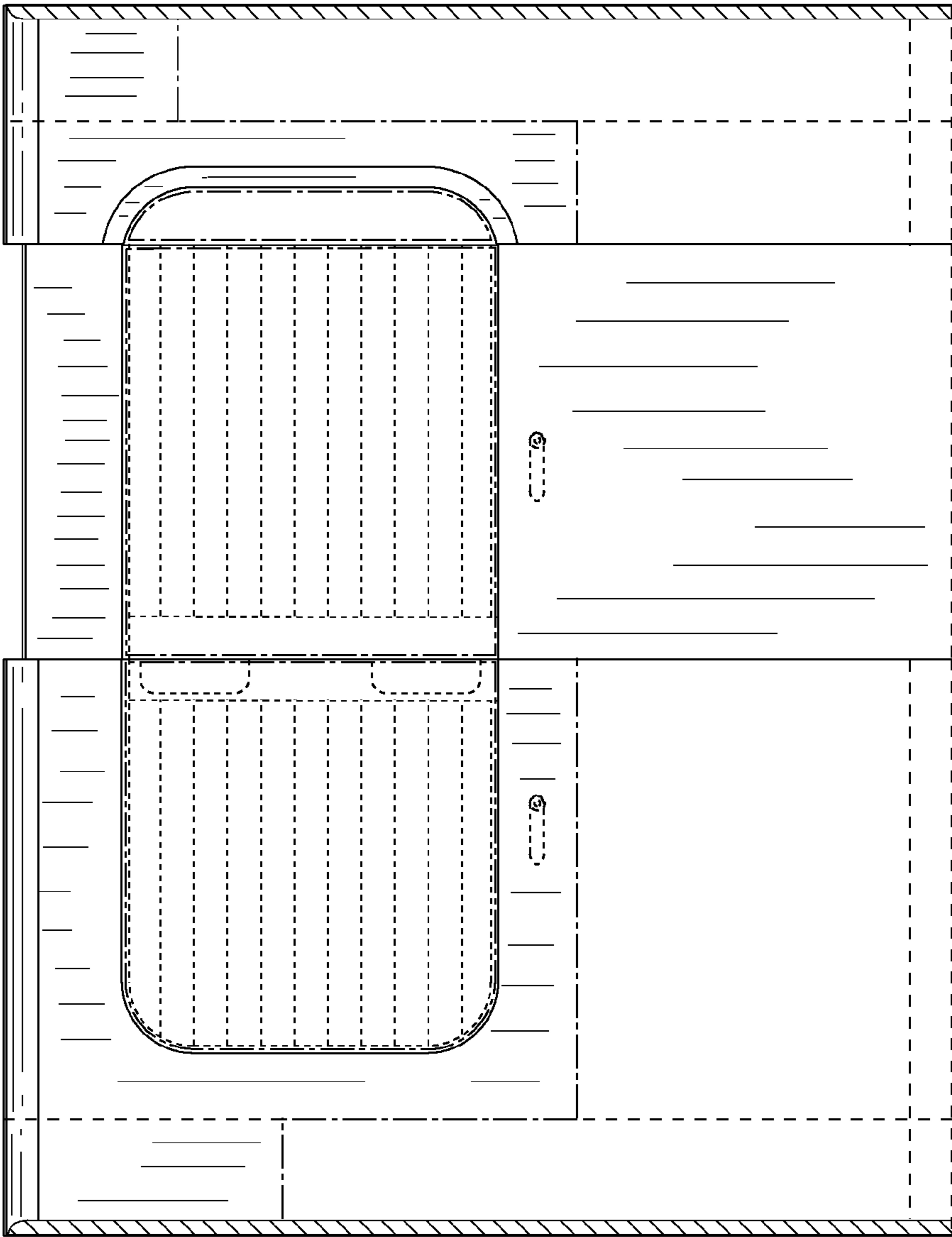


**FIG. 4**



**FIG. 5**





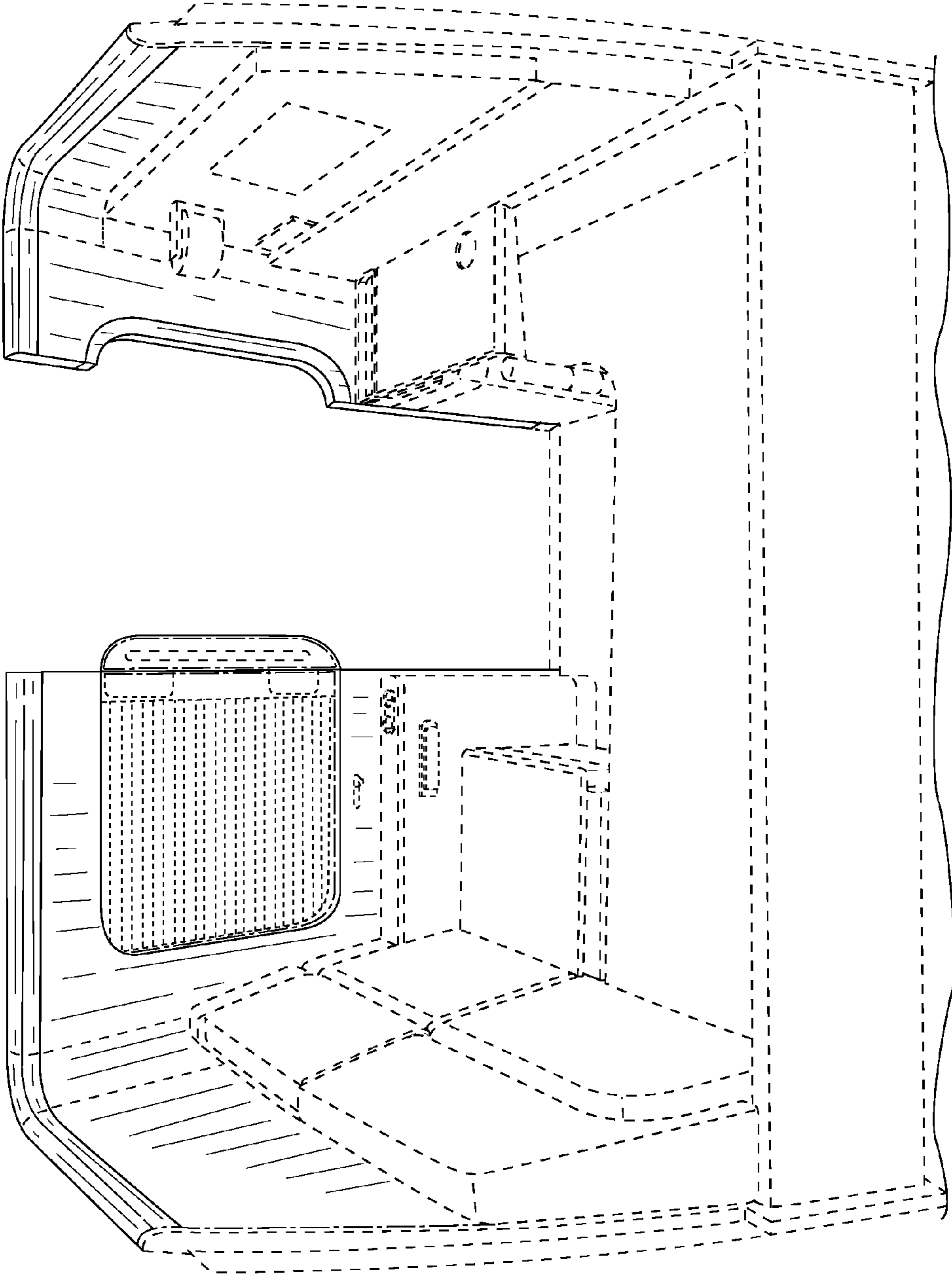
**FIG. 6**

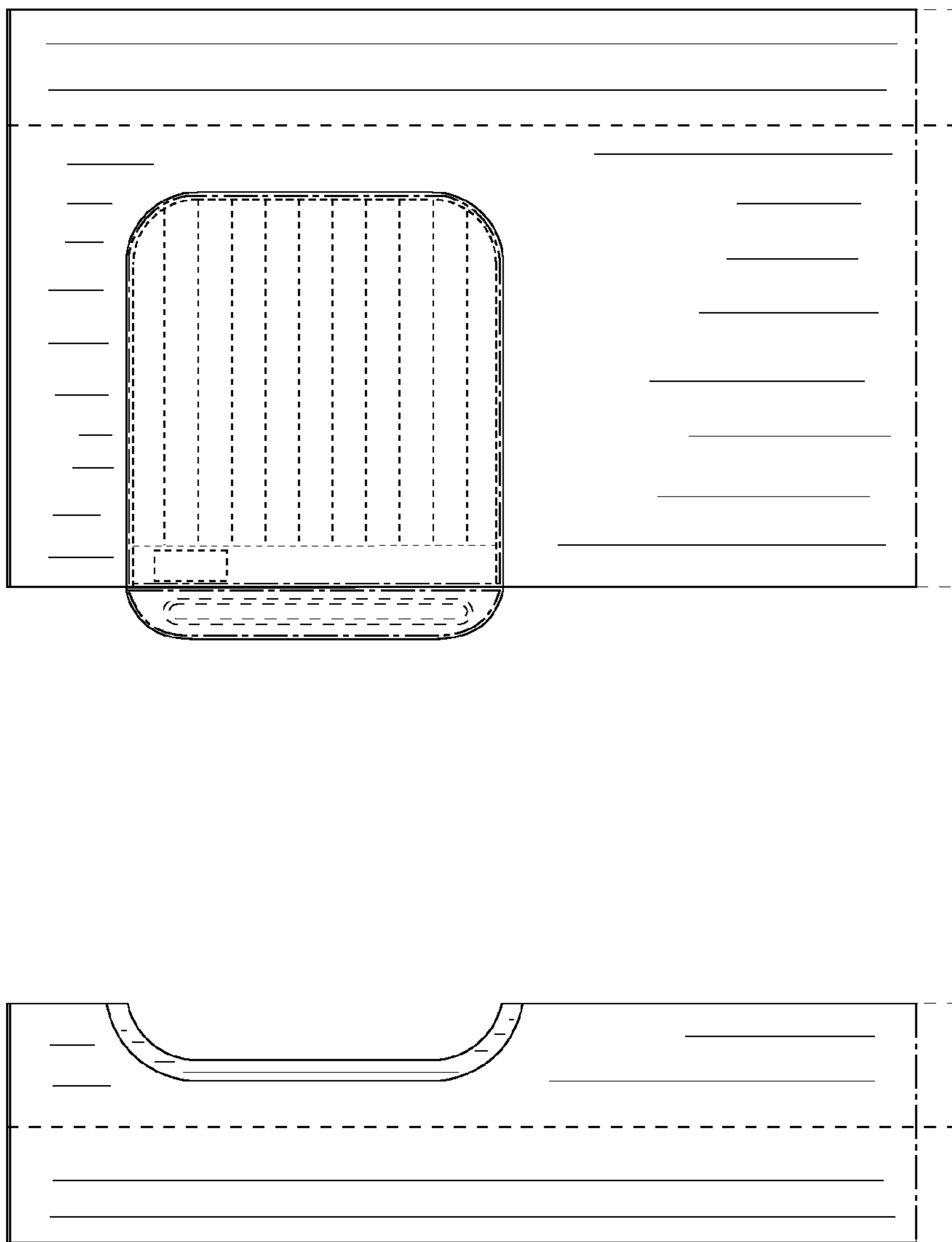




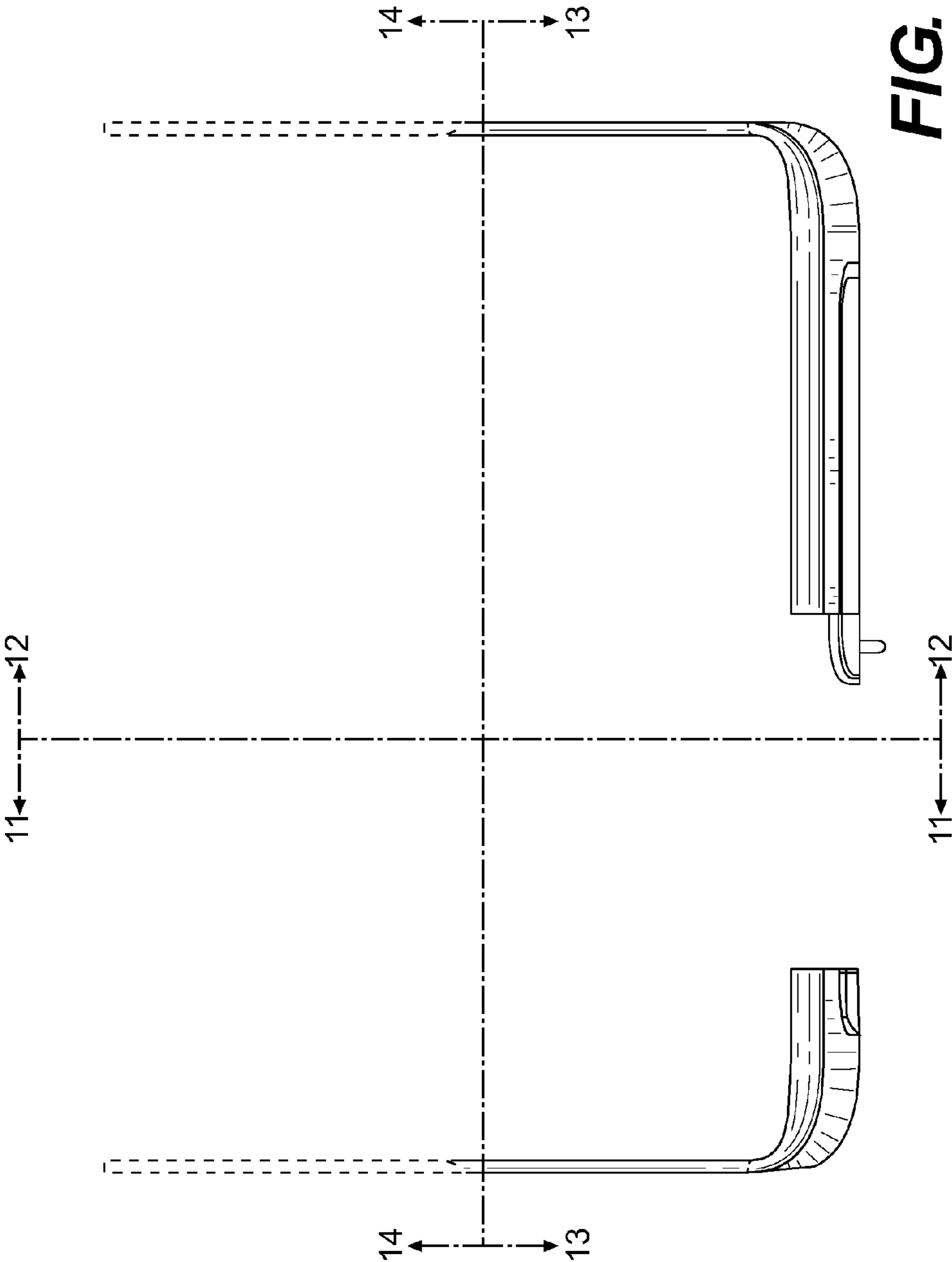
**FIG. 7**

FIG. 8

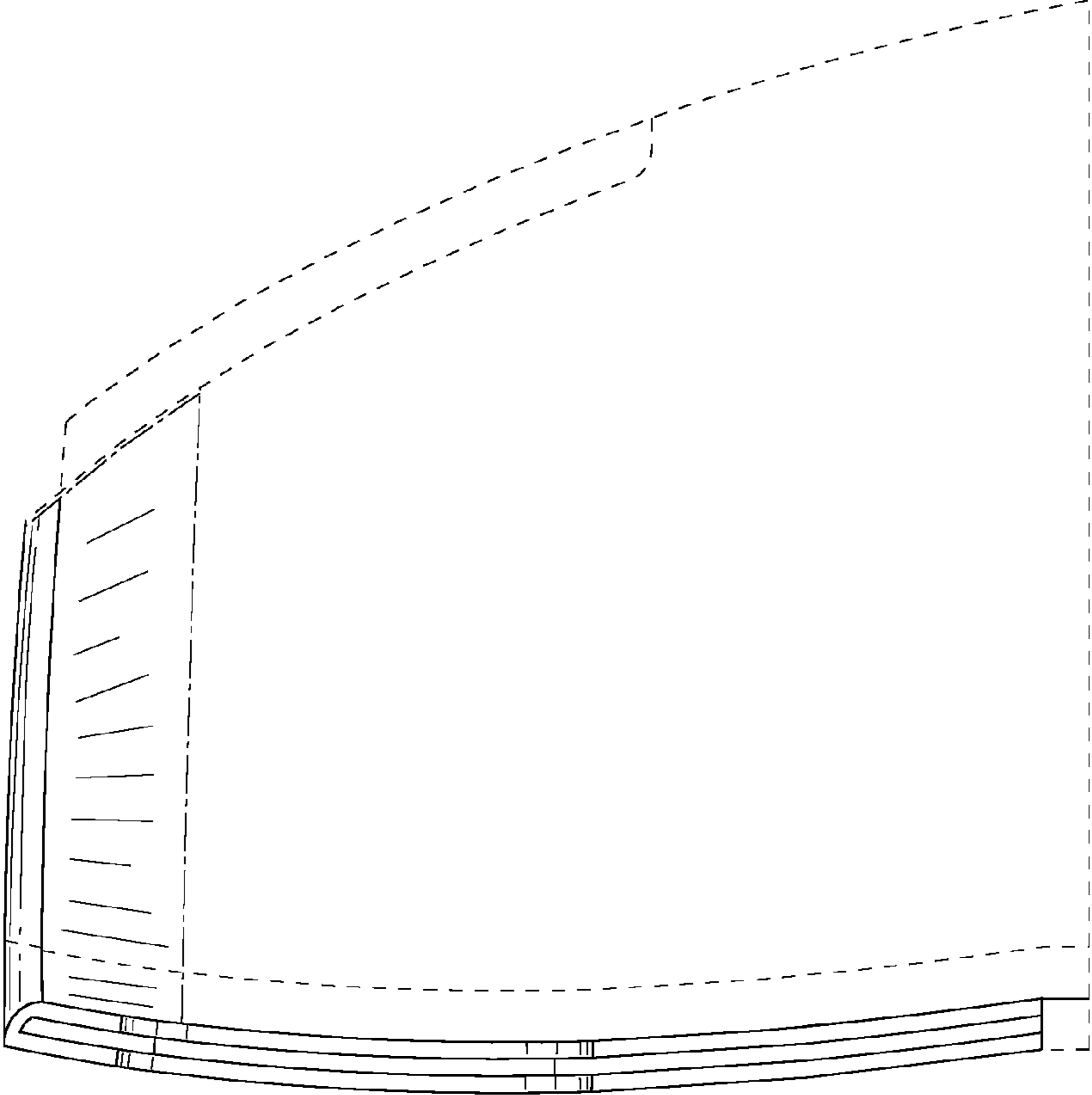




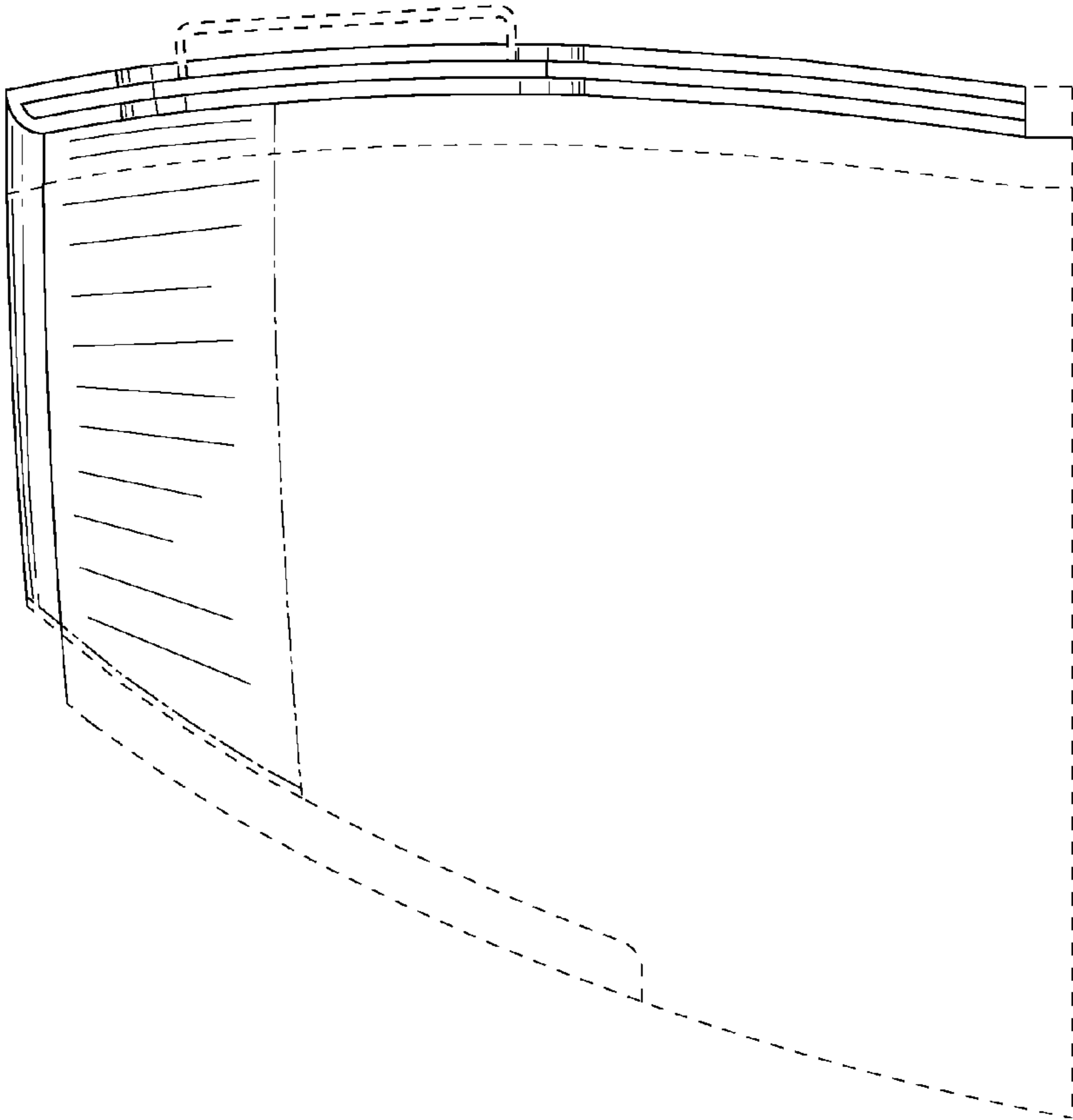
**FIG. 9**



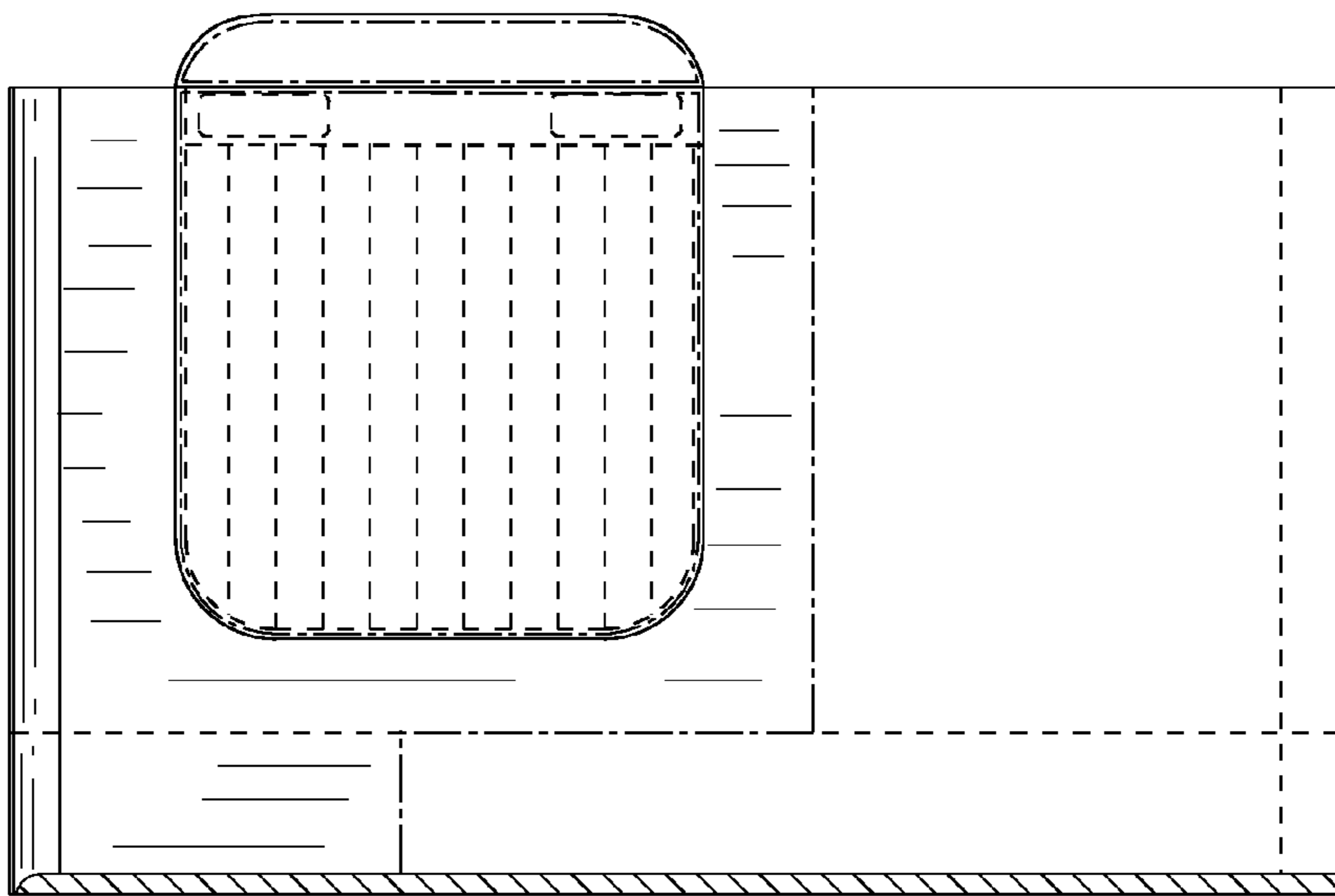
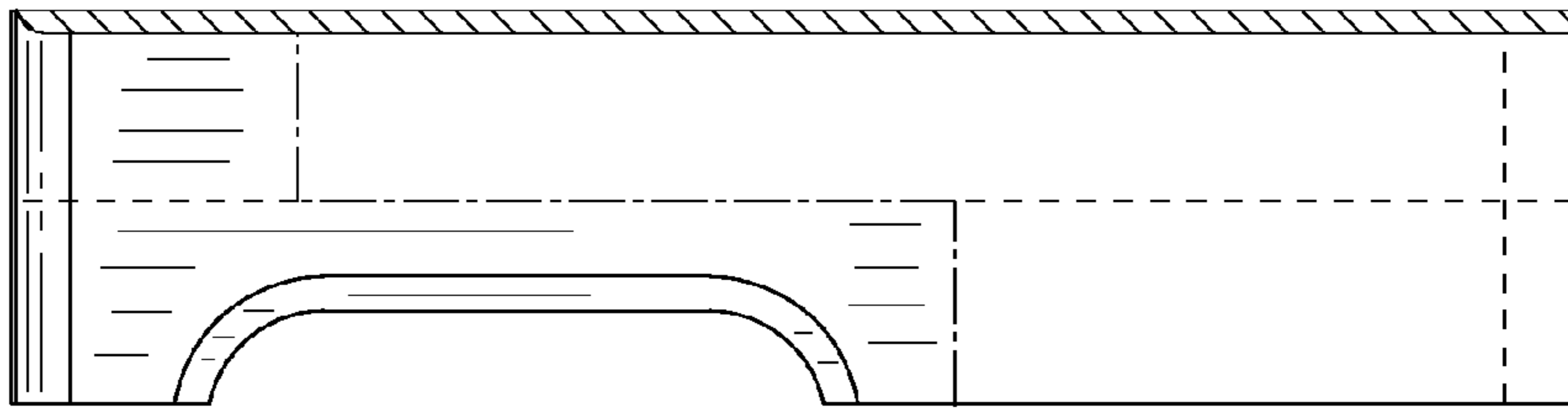
**FIG. 10**



**FIG. 11**



**FIG. 12**



**FIG. 13**





**FIG. 14**