



US00D628038S

(12) **United States Design Patent**  
**Aoki et al.**

(10) **Patent No.:** **US D628,038 S**

(45) **Date of Patent:** **\*\* Nov. 30, 2010**

(54) **PORTABLE ELECTRIC DRIVER**

(75) Inventors: **Yoshiki Aoki**, Hitachinaka (JP); **Shinichi Kakefuda**, Hitachinaka (JP); **Masayuki Ogura**, Hitachinaka (JP); **Tetsuya Monzen**, Hitachinaka (JP)

(73) Assignee: **Hitachi Koki Co., Ltd.**, Tokyo (JP)

(\*\*) Term: **14 Years**

(21) Appl. No.: **29/347,514**

(22) Filed: **Feb. 18, 2010**

(30) **Foreign Application Priority Data**

Aug. 19, 2009 (JP) ..... 2009-018917

(51) **LOC (9) Cl.** ..... **08-04**

(52) **U.S. Cl.** ..... **D8/68**

(58) **Field of Classification Search** ..... D8/61-70;  
81/57.11, 429, 454-456, 469, 489; 173/13,  
173/46, 104, 114, 167-173, 178, 201, 211,  
173/213, 214, 217, 198; 227/8, 113, 114,  
227/120, 130, 136, 142; 310/50; 408/20,  
408/35, 117, 124, 125, 234, 241 R, 58, 67;  
451/358; 7/158, 165

See application file for complete search history.

(56) **References Cited**

U.S. PATENT DOCUMENTS

D436,511 S \* 1/2001 Hayakawa et al. .... D8/68

D510,007 S \* 9/2005 Yamamoto ..... D8/68

D525,848 S \* 8/2006 Kokawa ..... D8/68  
7,108,079 B2 \* 9/2006 Sakai et al. .... 173/217  
D581,762 S \* 12/2008 Aglassinger ..... D8/68  
D589,317 S \* 3/2009 Okuda ..... D8/68  
D593,831 S \* 6/2009 Van Wambeke et al. .... D8/68  
D599,639 S \* 9/2009 Bradford et al. .... D8/68  
D605,014 S \* 12/2009 Yamamoto ..... D8/68  
D610,421 S \* 2/2010 Taniguchi et al. .... D8/68  
D614,468 S \* 4/2010 Aglassinger ..... D8/68  
D615,379 S \* 5/2010 Aglassinger ..... D8/68  
D617,621 S \* 6/2010 Houghton et al. .... D8/68

\* cited by examiner

*Primary Examiner*—Antoine D Davis

(74) *Attorney, Agent, or Firm*—McDermott Will & Emery LLP

(57) **CLAIM**

The ornamental design for a portable electric driver, as shown and described.

**DESCRIPTION**

FIG. 1 is a perspective view of top, front and left side of a portable electric driver showing our new design;

FIG. 2 is a front view thereof;

FIG. 3 is a rear view thereof;

FIG. 4 is a left side view thereof;

FIG. 5 is a right side view thereof;

FIG. 6 is a top plan view thereof; and,

FIG. 7 is a bottom view thereof.

**1 Claim, 6 Drawing Sheets**

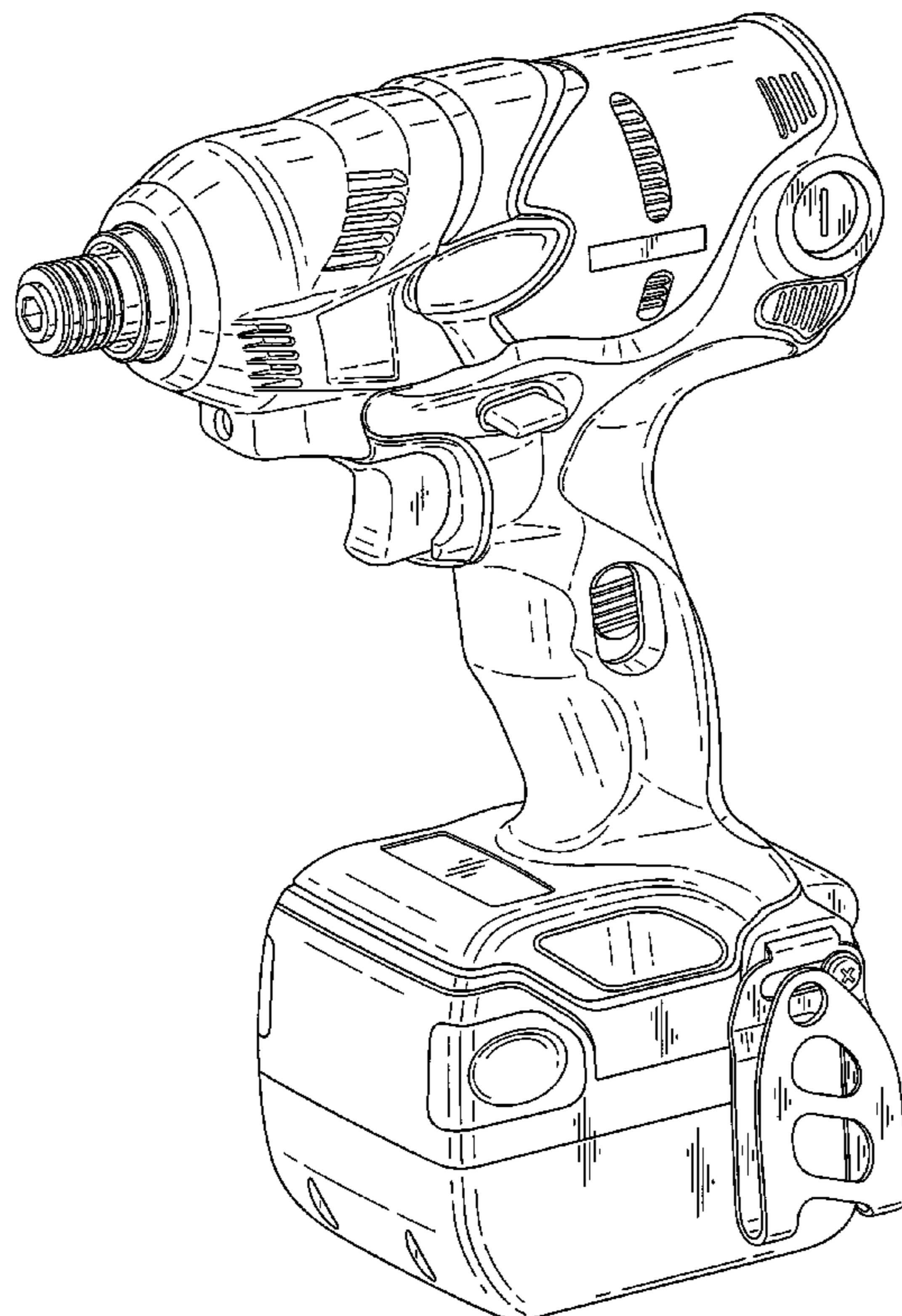

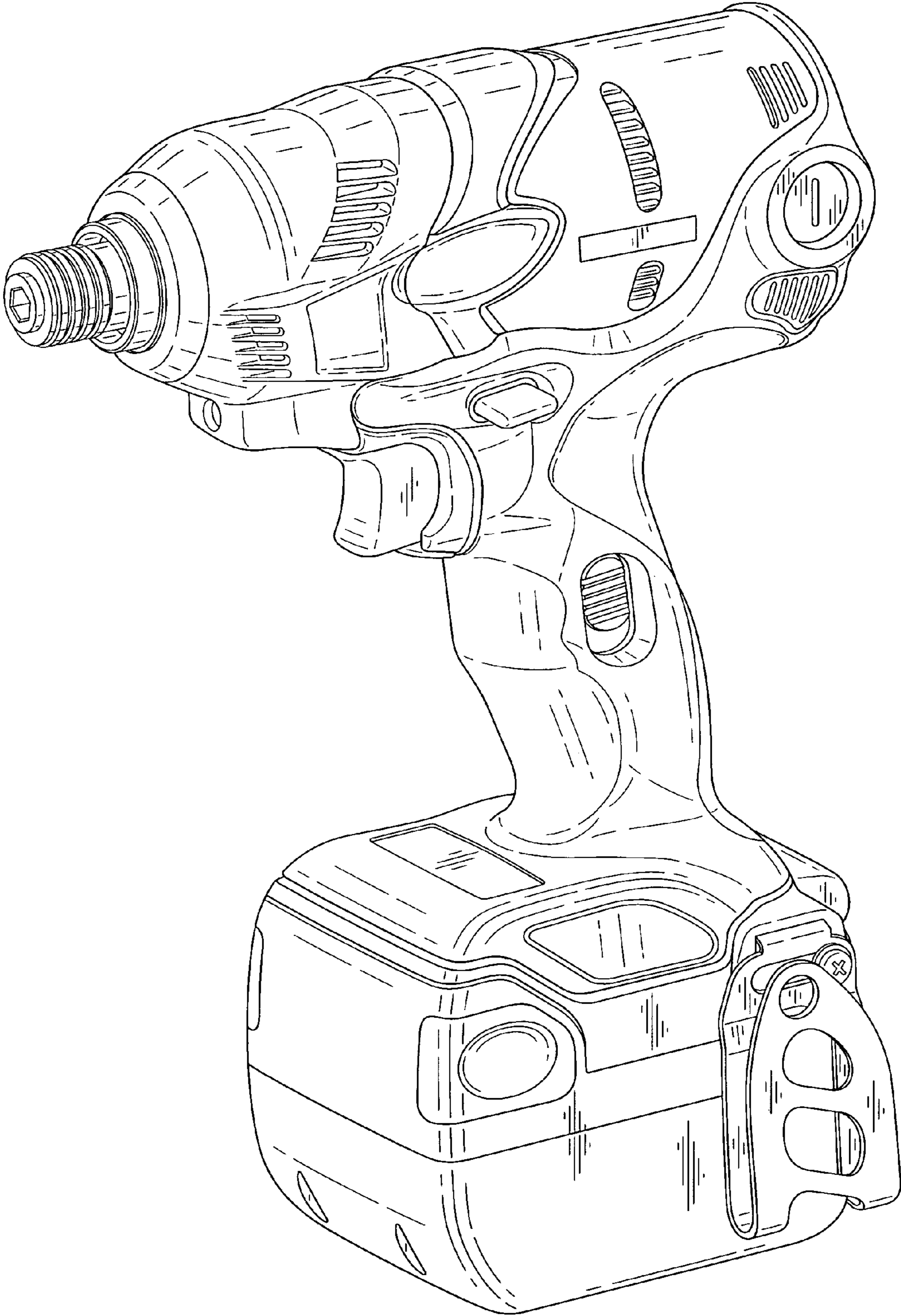

FIG. 1

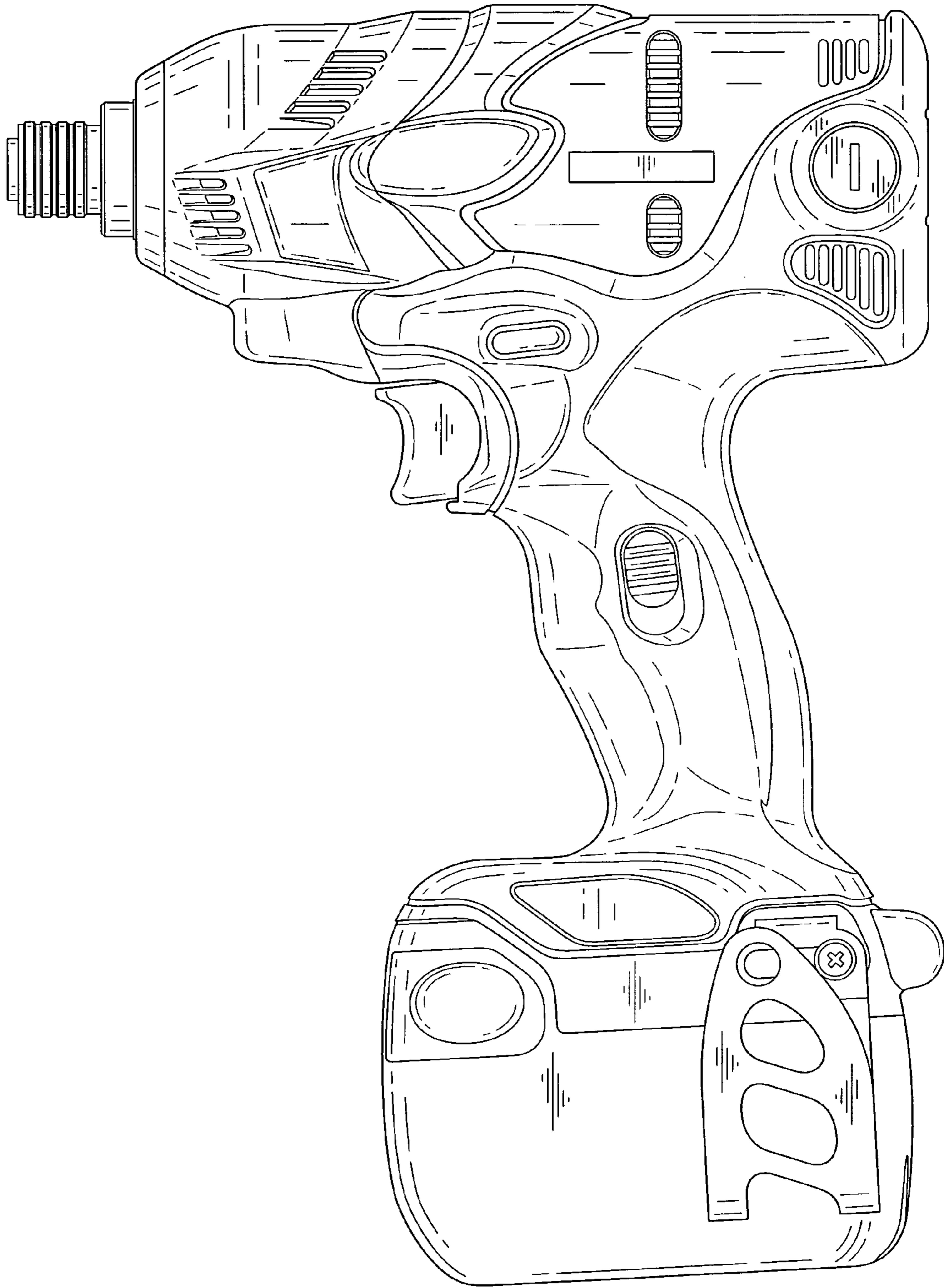

FIG. 2



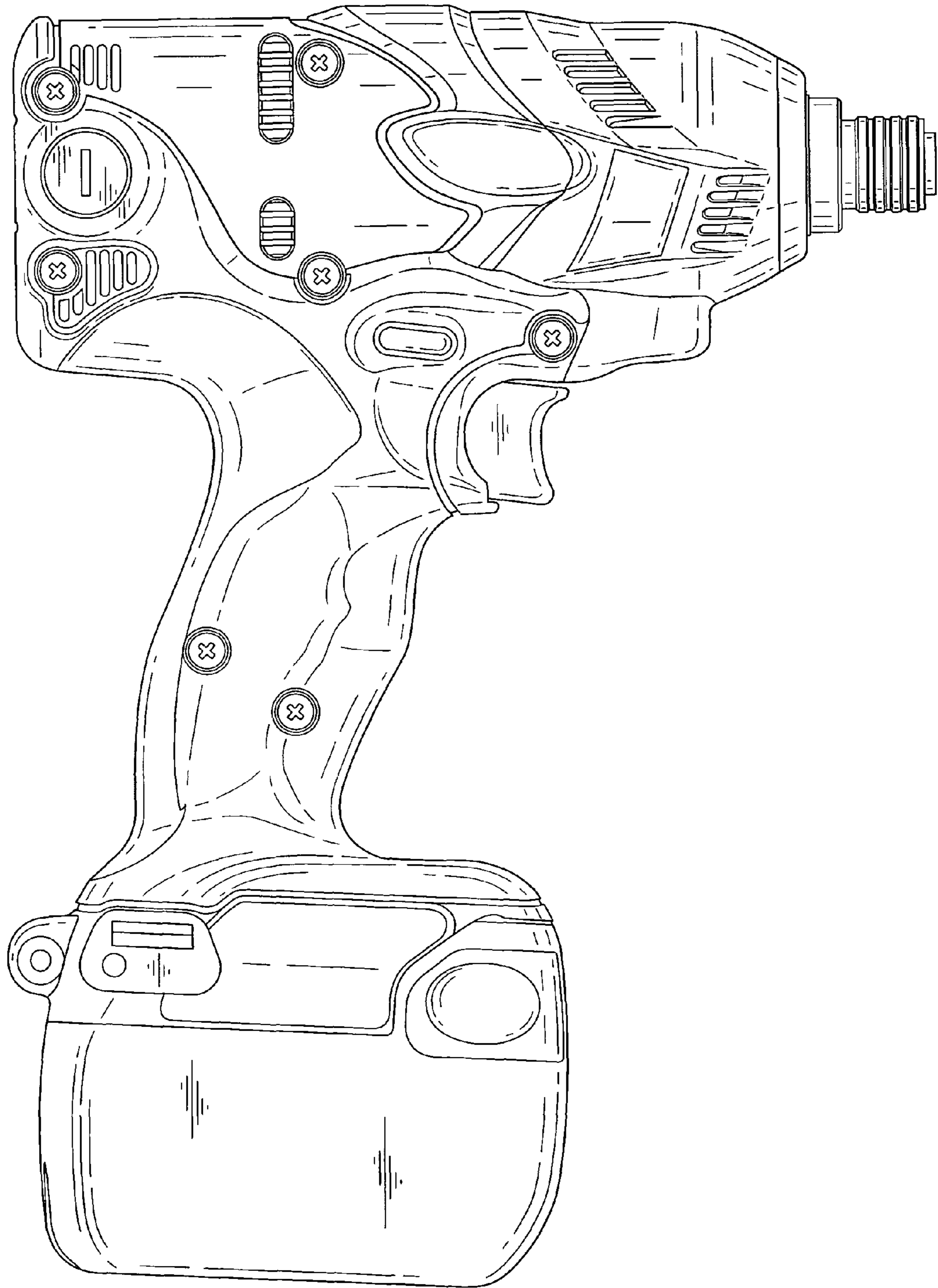

FIG. 3

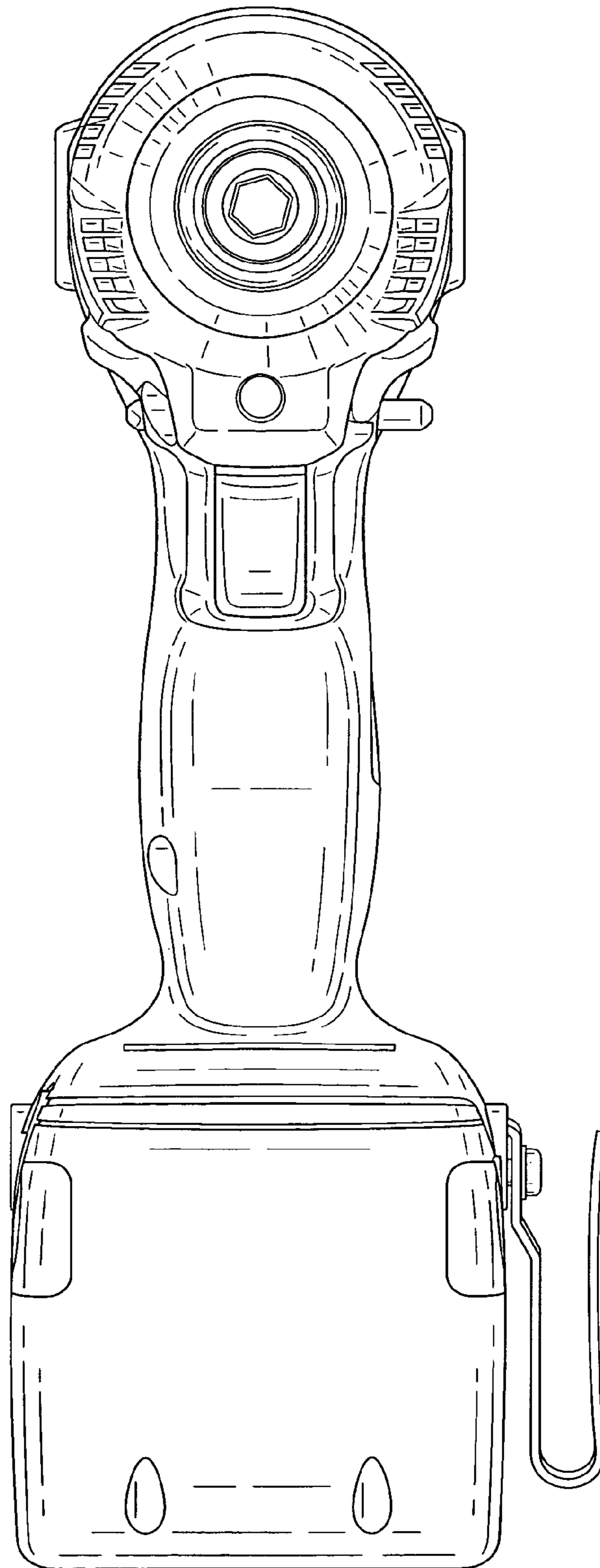

FIG. 4

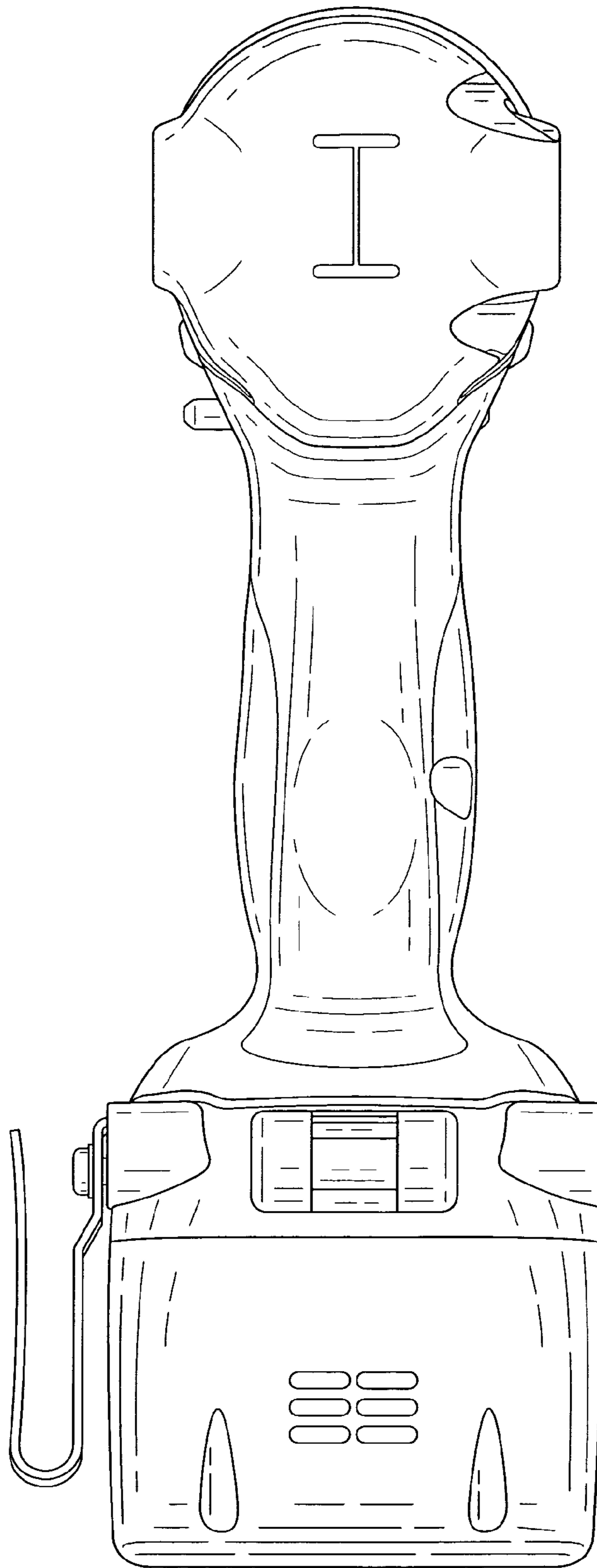

FIG. 5

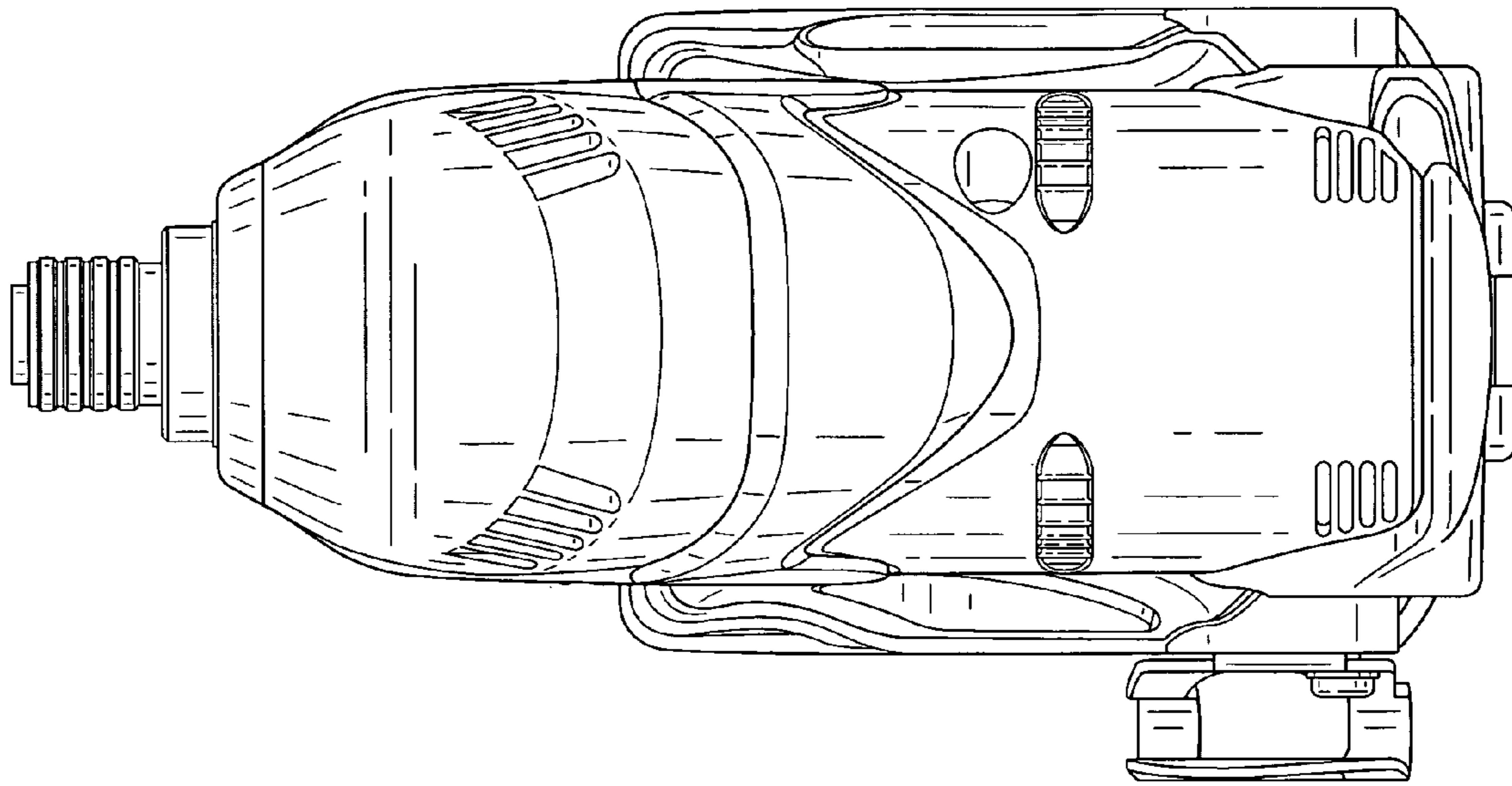

FIG. 6

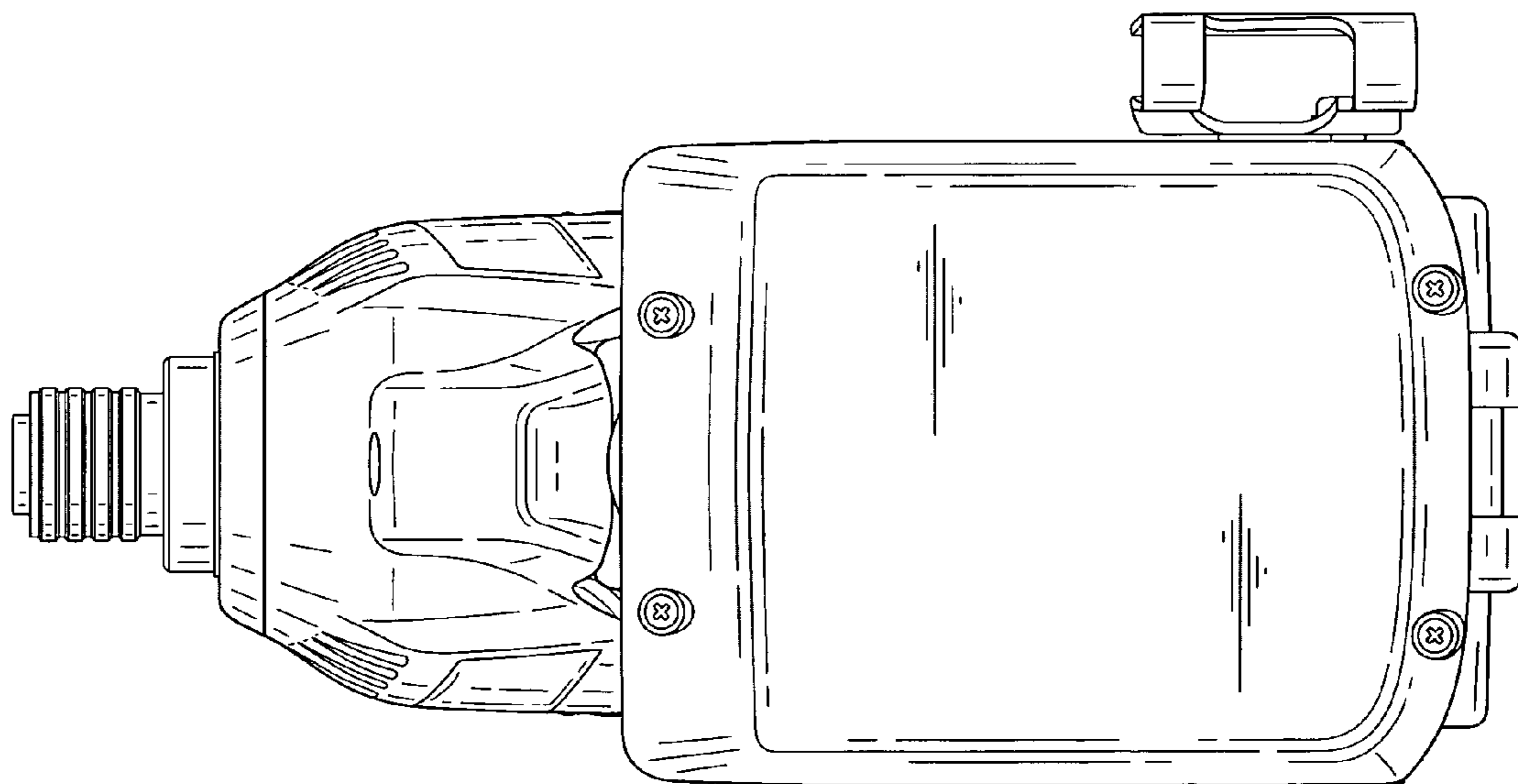

FIG. 7