



US00D627918S

(12) **United States Design Patent**
Espiau et al.

(10) **Patent No.:** **US D627,918 S**

(45) **Date of Patent:** **** *Nov. 23, 2010**

(54) **ELECTRODE-LESS LAMP WITH BASE**

(75) Inventors: **Frederick M. Espiau**, Topanga, CA (US); **Mehran Matloubian**, Encino, CA (US)

(73) Assignee: **Topanga Technologies, Inc.**, Canoga Park, CA (US)

(**) Term: **14 Years**

(21) Appl. No.: **29/355,398**

(22) Filed: **Feb. 6, 2010**

Related U.S. Application Data

(62) Division of application No. 29/337,185, filed on May 15, 2009, now Pat. No. Des. 612,093.

(51) **LOC (9) Cl.** **26-03**

(52) **U.S. Cl.** **D26/105**

(58) **Field of Classification Search** D26/1, D26/24, 36, 67, 93-94, 104-110; 362/3, 362/153, 186, 217, 255, 257, 277, 317, 351, 362/353, 362, 363, 382, 431, 433, 458, 806
See application file for complete search history.

(56) **References Cited**

U.S. PATENT DOCUMENTS

- D244,875 S * 6/1977 Baca D26/105
- D257,902 S * 1/1981 Scholze et al. D26/93
- D265,001 S * 6/1982 Graham D26/104
- 4,754,380 A * 6/1988 Wang 362/806
- 4,975,655 A 12/1990 Dawson et al.
- 5,686,793 A 11/1997 Turner et al.
- 5,777,857 A 7/1998 Degelmann
- 5,838,108 A 11/1998 Frank et al.
- D406,379 S * 3/1999 Andrews D26/96
- 5,886,480 A 3/1999 Penzenstadler et al.
- 5,923,122 A 7/1999 Frank et al.
- 6,241,369 B1 6/2001 Mackiewicz
- 6,476,557 B1 11/2002 Leng et al.
- 6,617,806 B2 9/2003 Kirkpatrick et al.
- D488,582 S * 4/2004 Connelly et al. D26/96

- 6,737,809 B2 5/2004 Espiau et al.
- 6,922,021 B2 7/2005 Espiau et al.
- 7,119,641 B2 10/2006 Petrov et al.
- D536,473 S * 2/2007 Tan D26/93
- D537,190 S * 2/2007 Lyall et al. D26/96
- 7,348,732 B2 3/2008 Espiau et al.
- 7,350,936 B2 4/2008 Ducharme et al.
- 7,358,678 B2 4/2008 Espiau et al.
- 7,362,054 B2 4/2008 Espiau et al.
- 7,362,055 B2 4/2008 Espiau et al.

(Continued)

OTHER PUBLICATIONS

Requirement for Restriction/Election for U.S. Design Appl. No. 29/337,185, mailed on Sep. 16, 2009, 5 pages.

(Continued)

Primary Examiner—Brian N Vinson
(74) *Attorney, Agent, or Firm*—Townsend and Townsend and Crew LLP

(57) **CLAIM**

The ornamental design for electrode-less lamp with base, as shown and described.

DESCRIPTION

FIG. 1 is a top and front perspective view of an electrode-less lamp with base showing our new design;
FIG. 2 is a front elevational view thereof;
FIG. 3 is a top plan view thereof; and,
FIG. 4 is bottom plan view thereof.
The broken lines shown represent unclaimed subject matter and form no part of the claimed design.

1 Claim, 3 Drawing Sheets

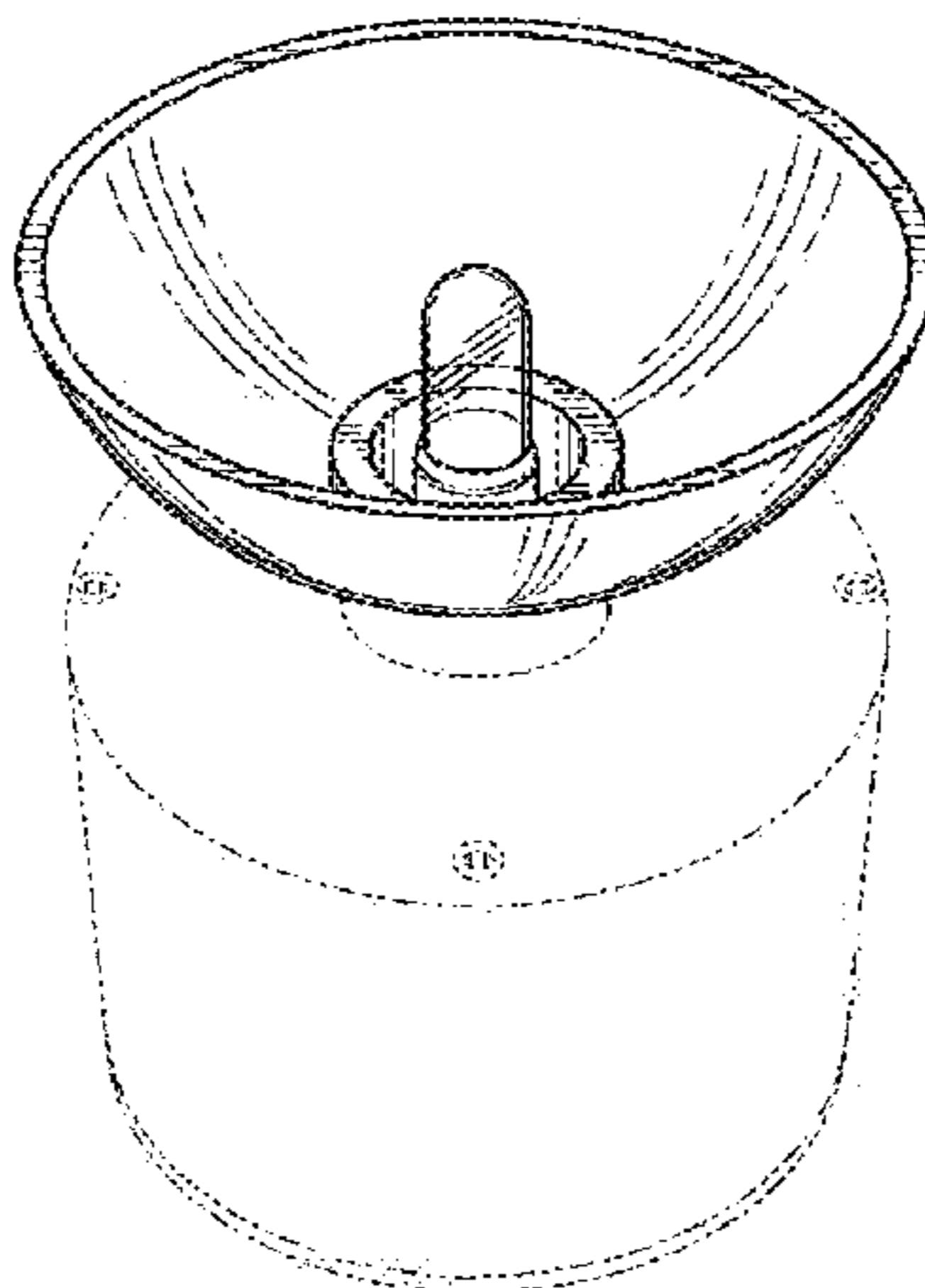

US D627,918 S

Page 2

U.S. PATENT DOCUMENTS

7,362,056 B2 4/2008 Espiau et al.
D569,541 S * 5/2008 Shiu D26/96
7,372,209 B2 5/2008 Espiau et al.
D571,498 S * 6/2008 Dyson D26/93
7,391,158 B2 6/2008 Espiau et al.
D612,093 S 3/2010 Espiau et al.

2006/0250090 A9 11/2006 Guthrie

OTHER PUBLICATIONS

Notice of Allowance for U.S. Design Appl. No. 29/337,185, mailed on Oct. 30, 2009, 6 pages.

Notice of Allowance for U.S. Design Appl. No. 29/355,398, mailed on Apr. 5, 2010, 7 pages.

* cited by examiner

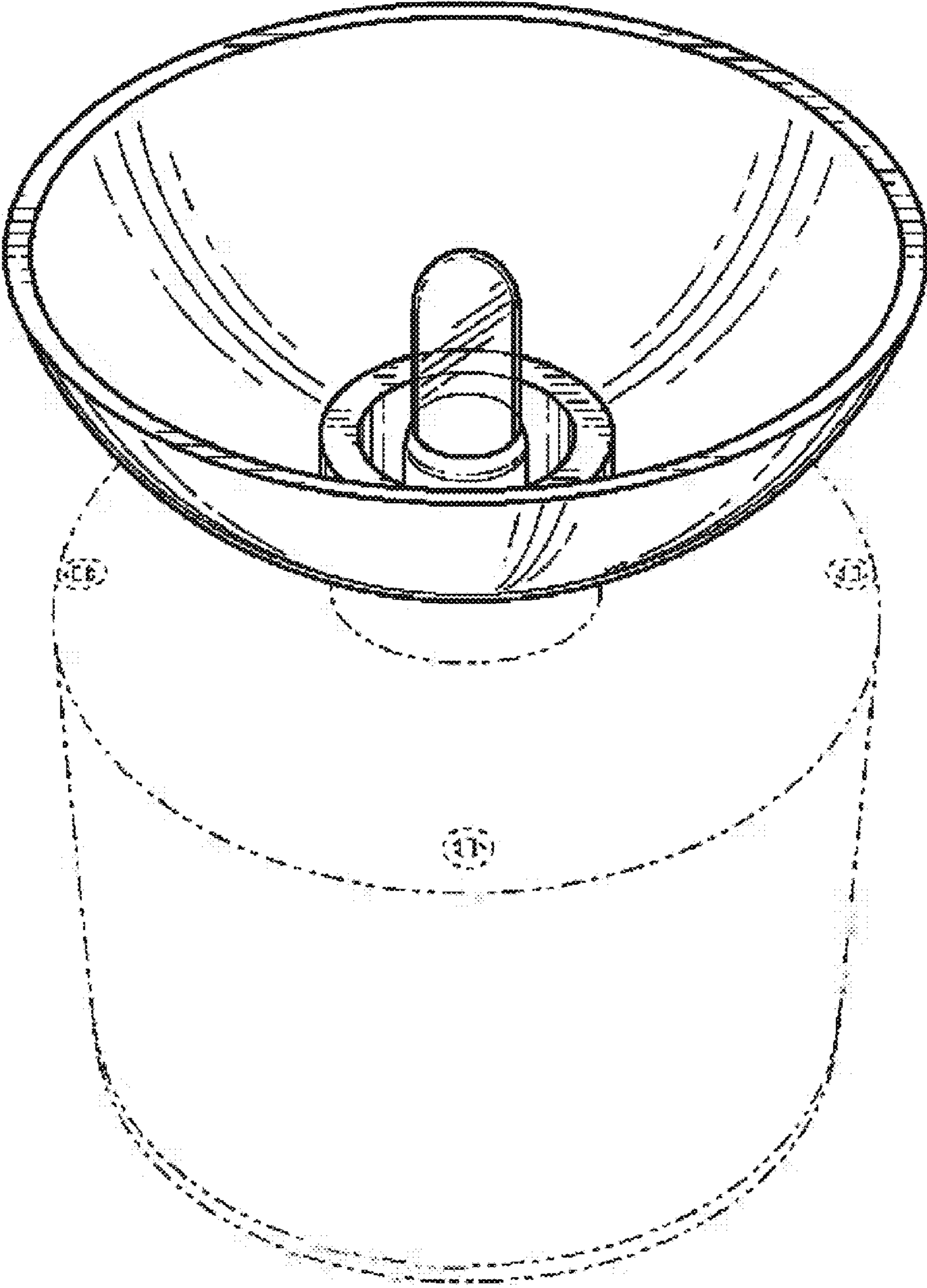

FIG. 1

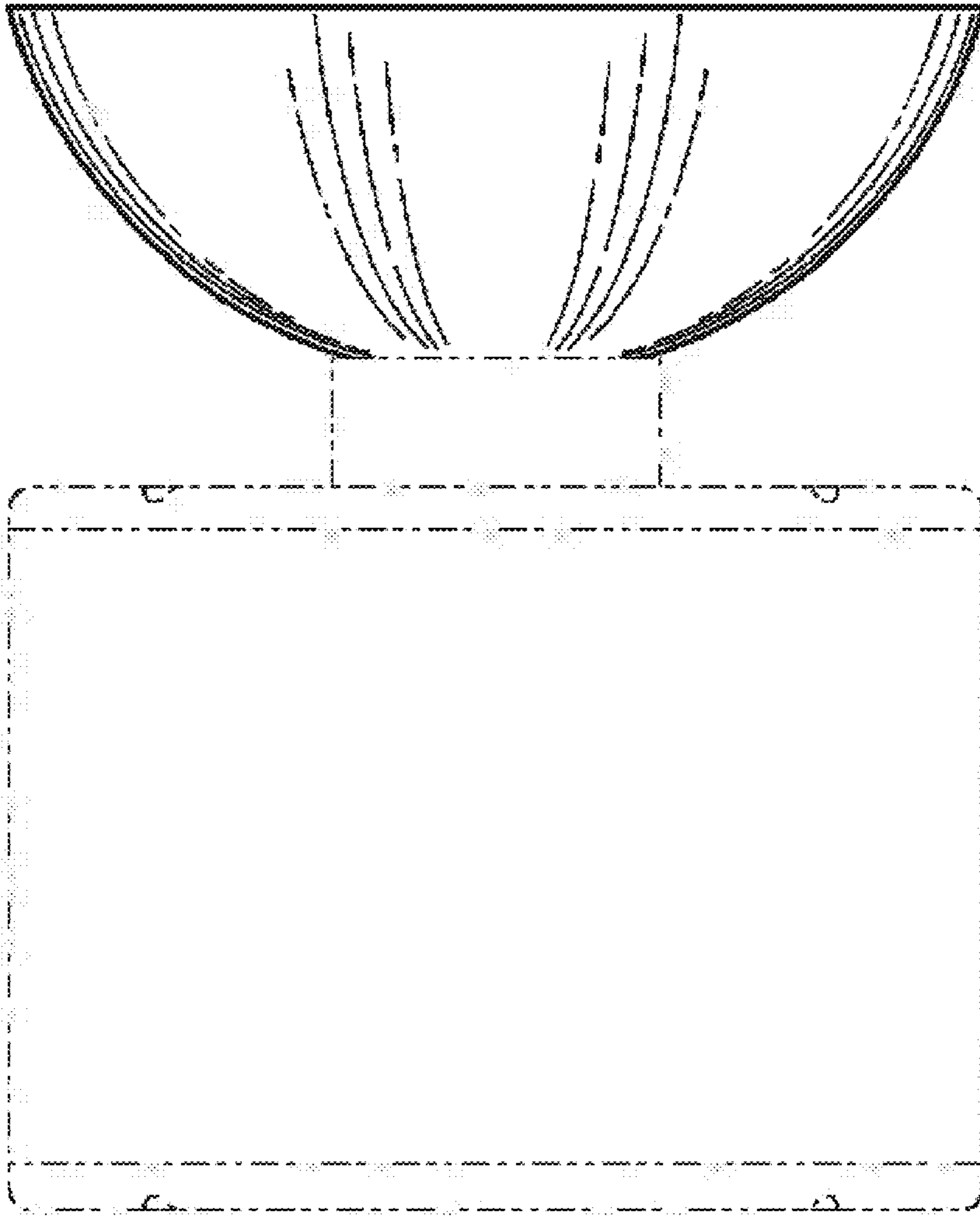

FIG. 2

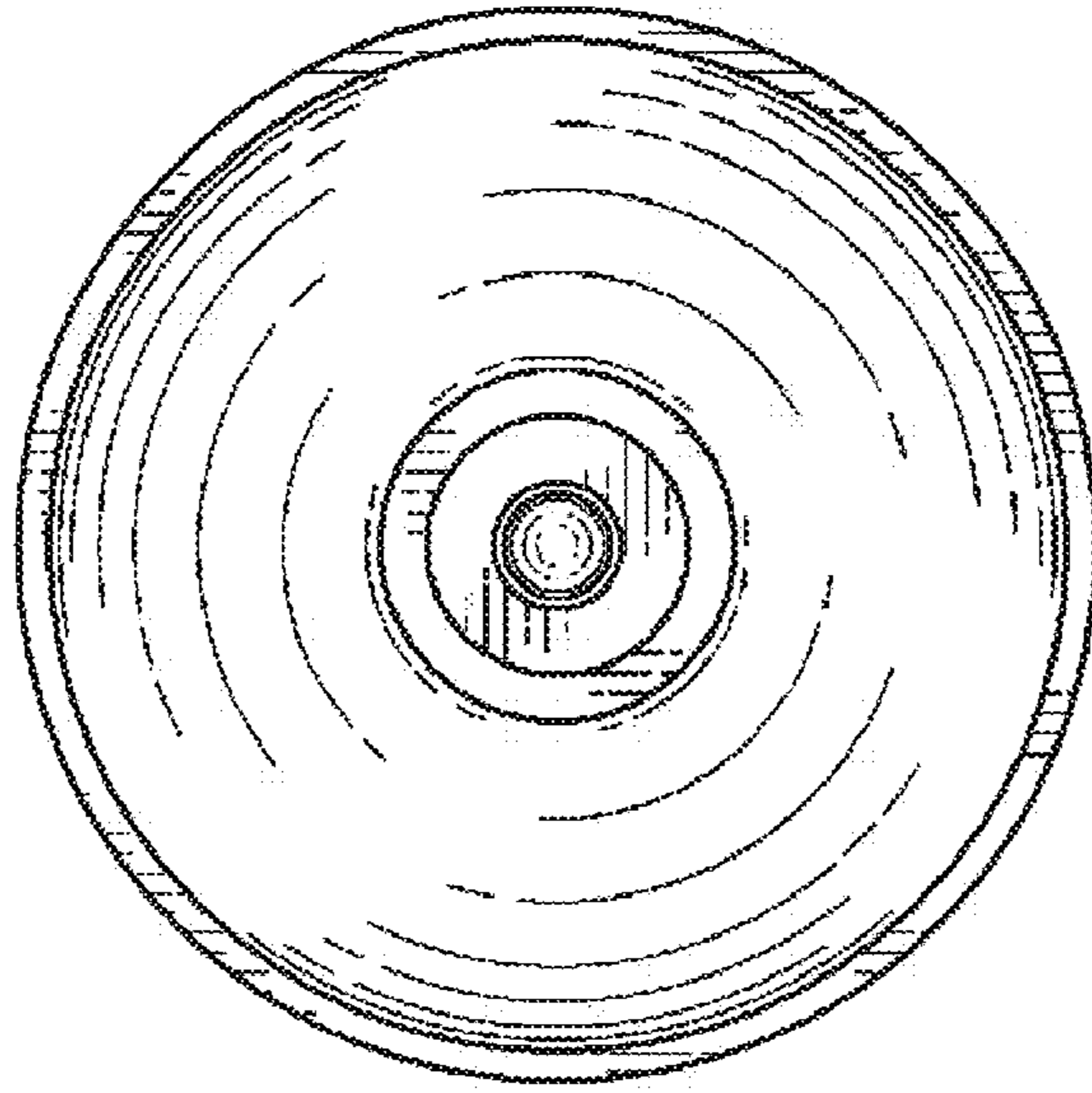

FIG. 3

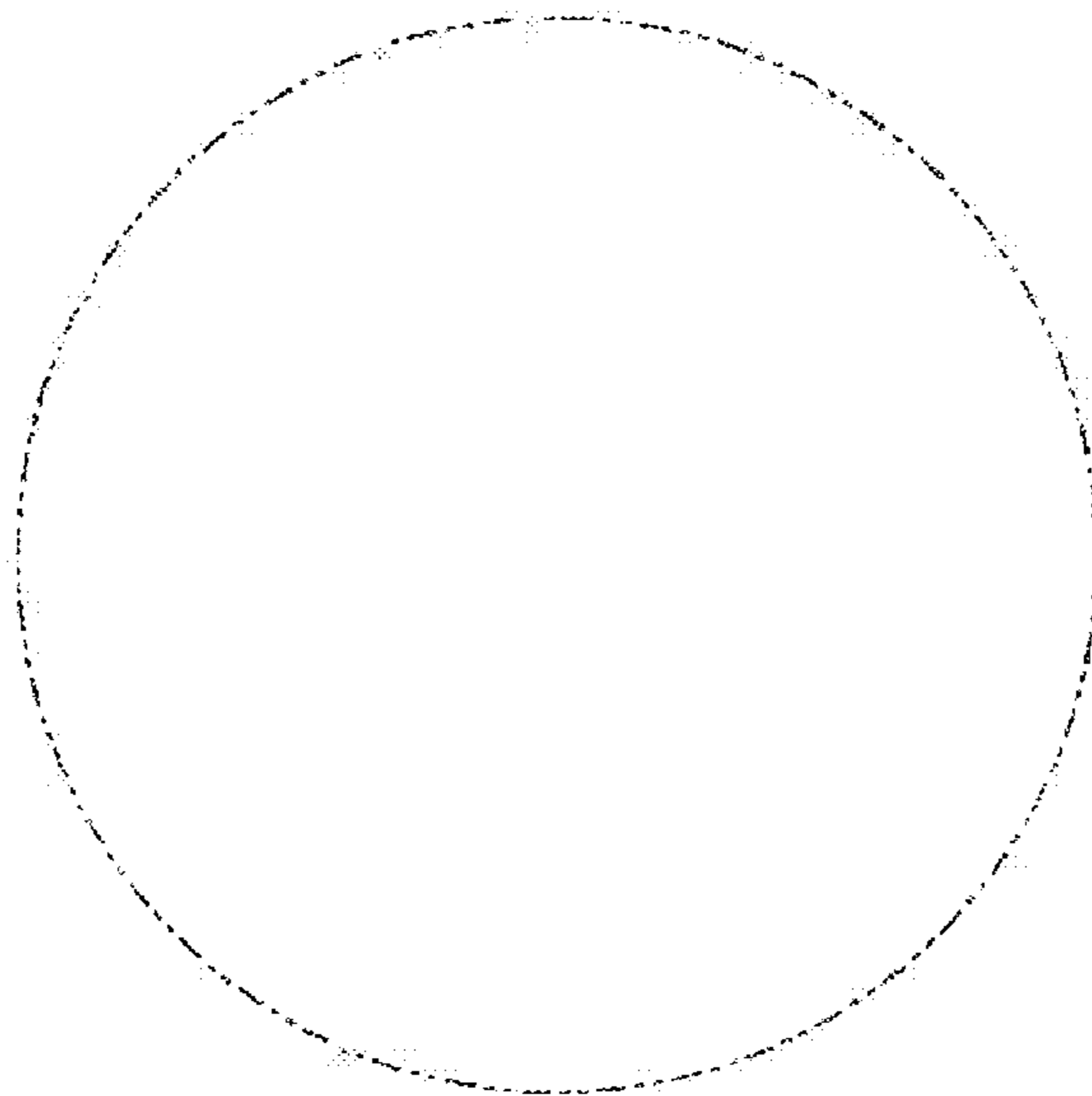

FIG. 4