



US00D627703S

(12) **United States Design Patent**
McLaughlin

(10) **Patent No.:** **US D627,703 S**

(45) **Date of Patent:** **** Nov. 23, 2010**

(54) **POLE HOLDING DEVICE**

D492,871 S * 7/2004 Alves D6/552
7,290,690 B2 * 11/2007 Hancock 224/441

(76) Inventor: **William G McLaughlin**, P.O. Box 55,
Joshua Tree, CA (US) 92252

* cited by examiner

(**) Term: **14 Years**

Primary Examiner—Caron Veynar

Assistant Examiner—Katrina A Kile

(21) Appl. No.: **29/363,177**

(74) *Attorney, Agent, or Firm*—Eric Hanscom; Todd J.
Langford

(22) Filed: **Jun. 5, 2010**

(57) **CLAIM**

(51) **LOC (9) Cl.** **12-16**

The ornamental design for a pole holding device, as shown
and described.

(52) **U.S. Cl.** **D12/406**

(58) **Field of Classification Search** D12/413,
D12/414, 406, 412, 414.1; 206/213, 8, 9,
206/279, 290, 713, 335, 315.1–315.4; D32/35,
D32/38; D6/317–319, 513–514, 552; 293/37.1,
293/3, 100; 224/309–310, 315–316, 323–329,
224/400; D3/304–306; 280/760–762, 848,
280/727, 769; 296/99.1, 37.1, 100.01, 100.02,
296/157

DESCRIPTION

See application file for complete search history.

FIG. 1 is a perspective view of a pole holding device showing
my new design;

FIG. 2 is an enlarged perspective view of the encircled area
shown in FIG. 1;

FIG. 3 is a right-side view thereof;

FIG. 4 is a top view thereof;

FIG. 5 is a left-side view thereof;

FIG. 6 is a bottom view thereof;

FIG. 7 is a back view thereof; and,

FIG. 8 is a front view thereof.

In the drawings, the broken lines depict a truck and a pole and
form no part of the claimed design.

(56) **References Cited**

U.S. PATENT DOCUMENTS

3,329,385 A * 7/1967 Dietsch 248/290.1
D302,262 S * 7/1989 Dickerman D12/412
4,954,030 A * 9/1990 Szucs et al. 410/96
D313,915 S * 1/1991 Adams et al. D6/552
D314,287 S * 2/1991 Albright, Sr. D6/417
D314,302 S * 2/1991 Snow D6/552
6,752,302 B2 * 6/2004 Anton 224/517

1 Claim, 3 Drawing Sheets

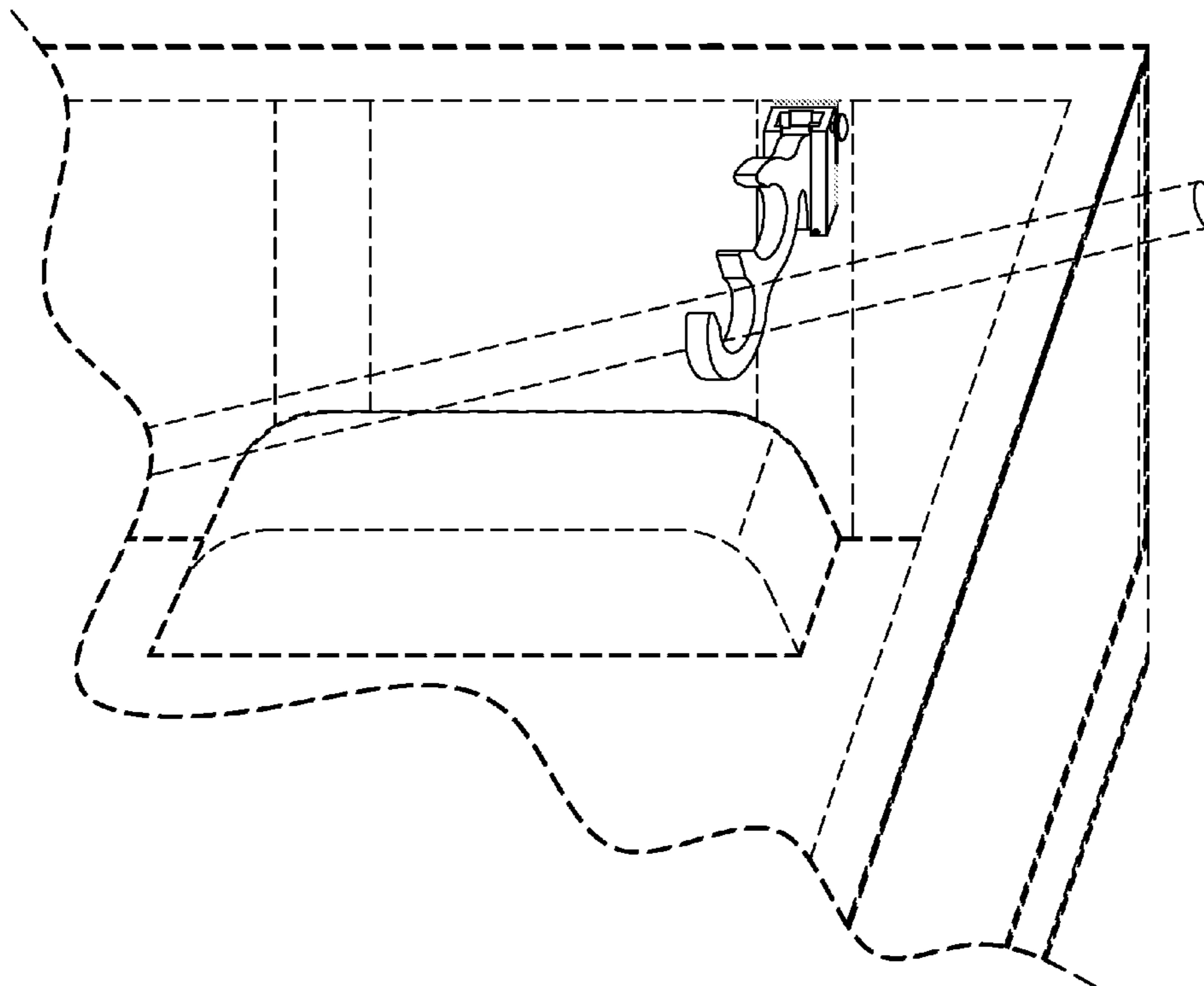

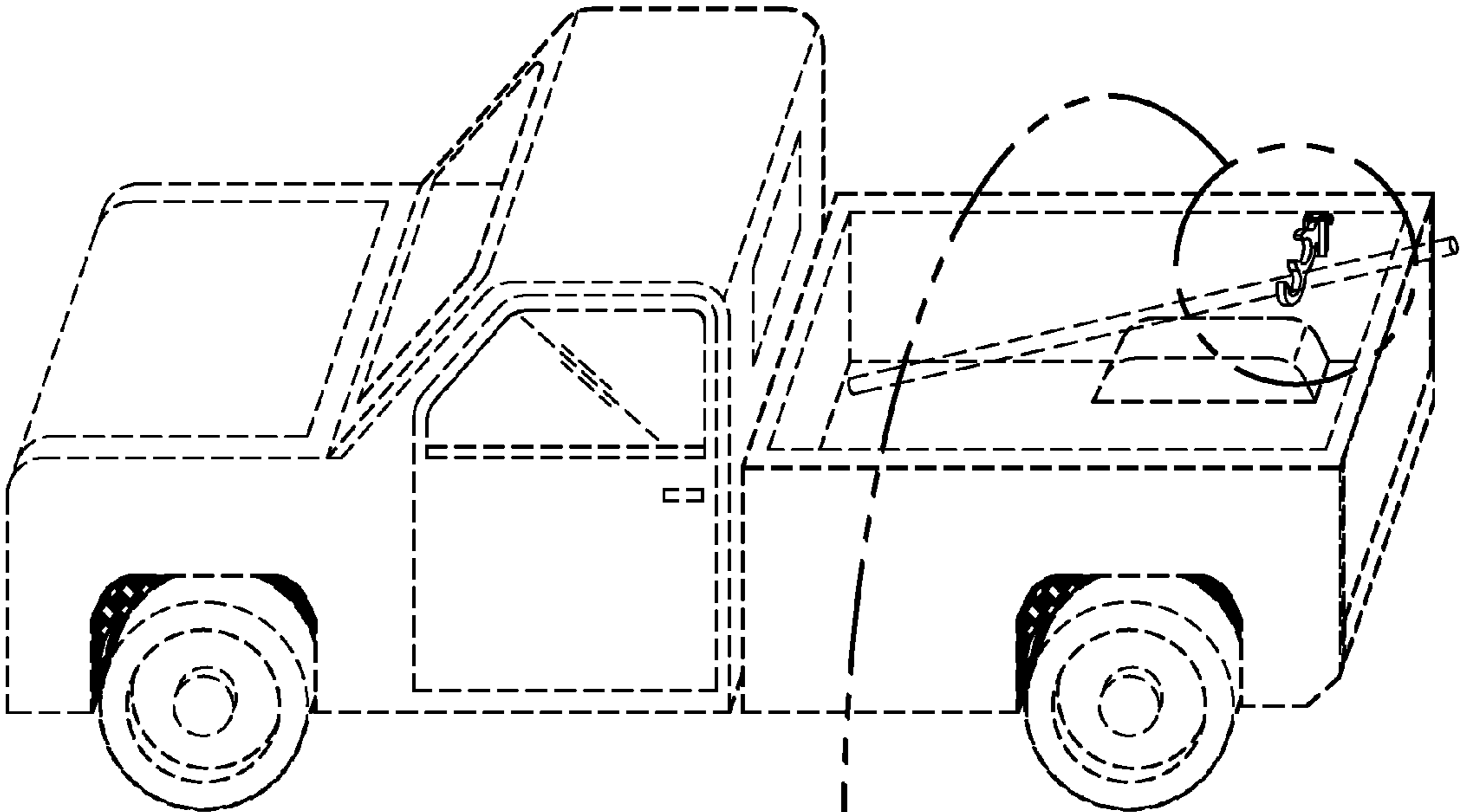

FIG. 1

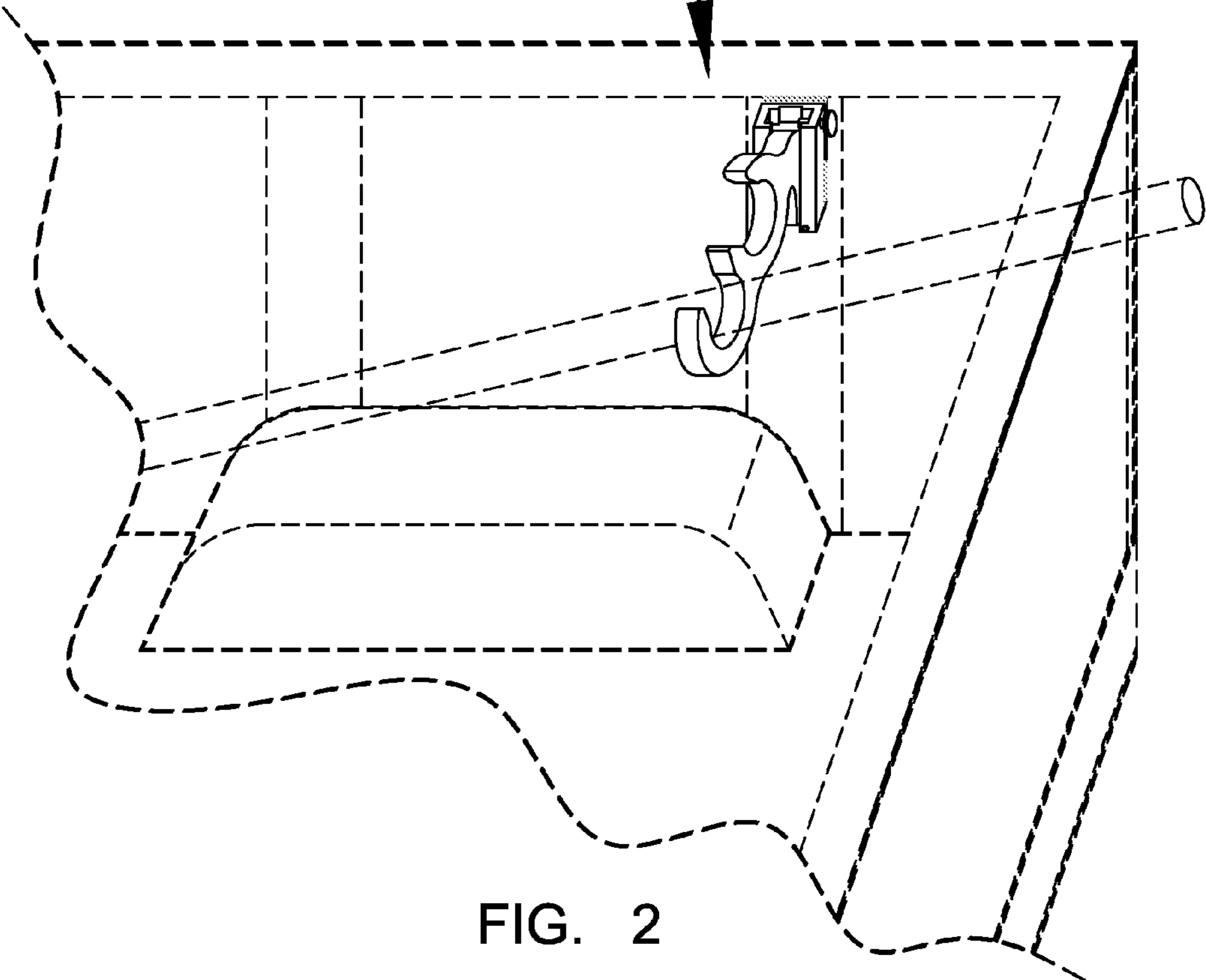

FIG. 2

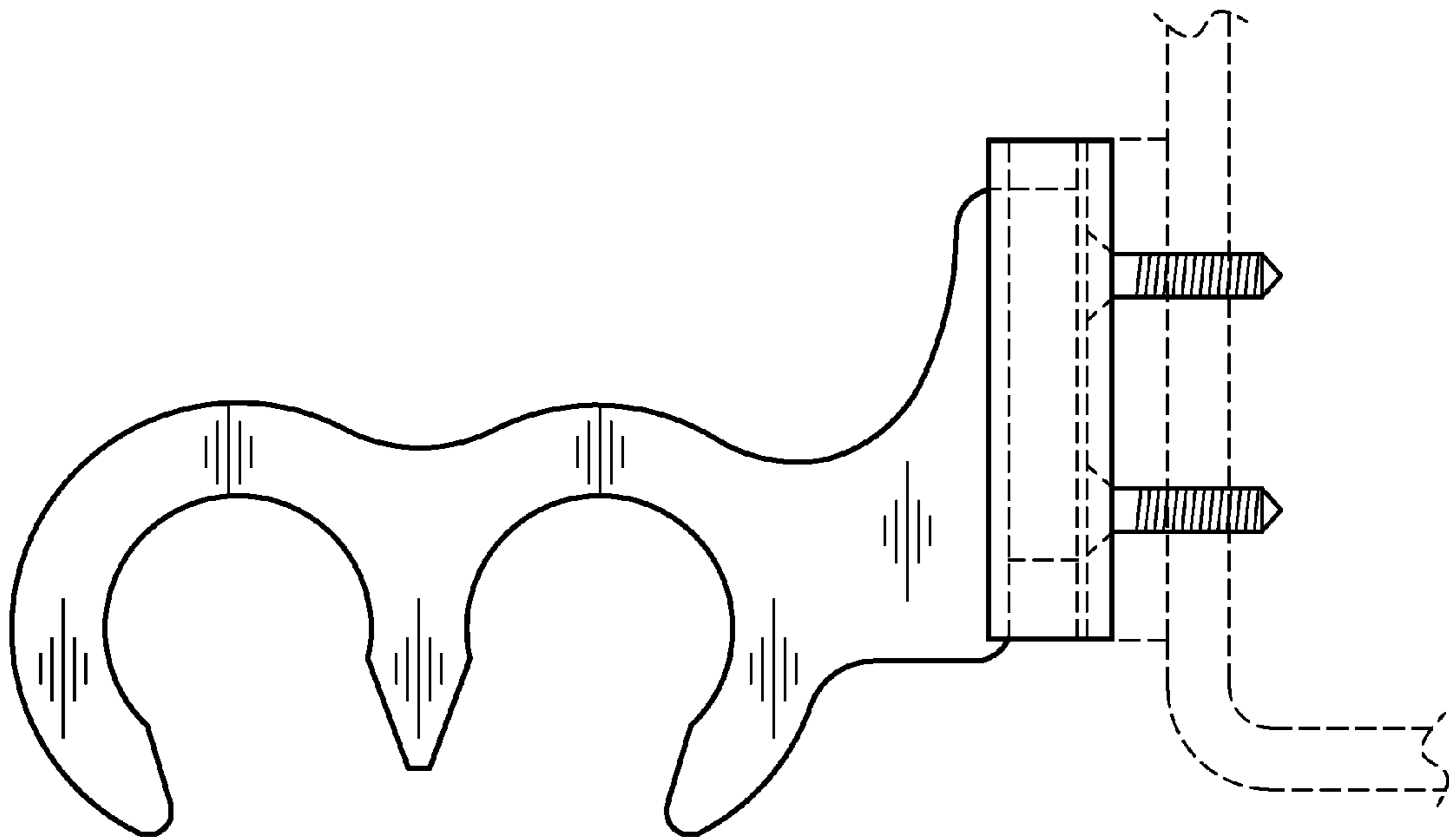

FIG. 3

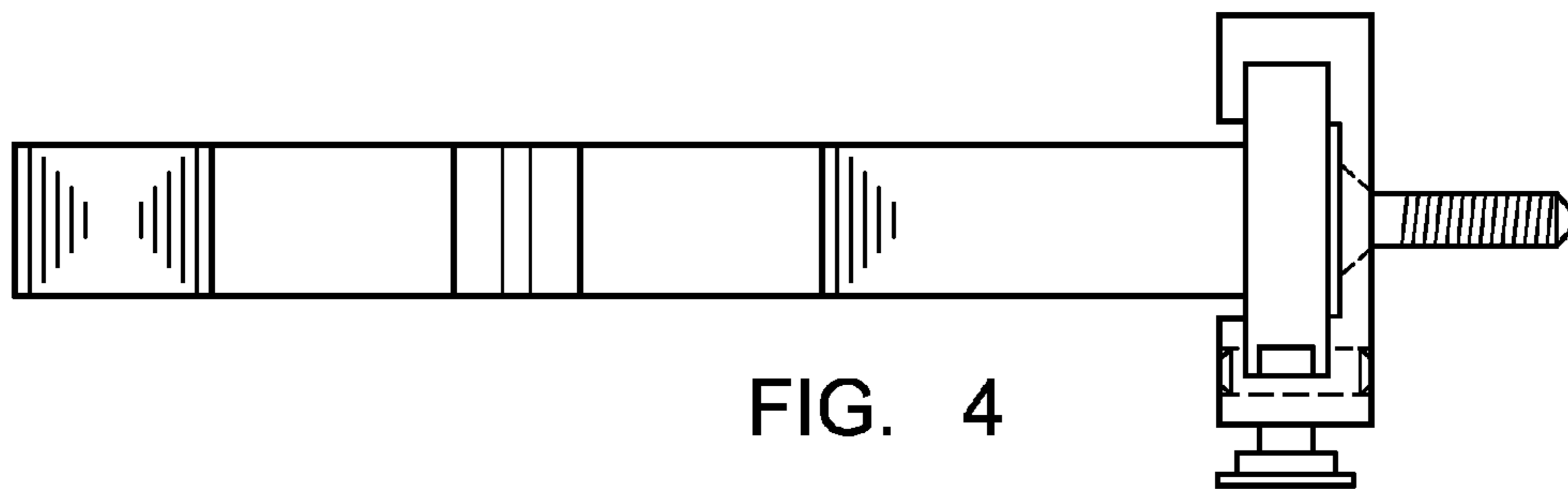

FIG. 4

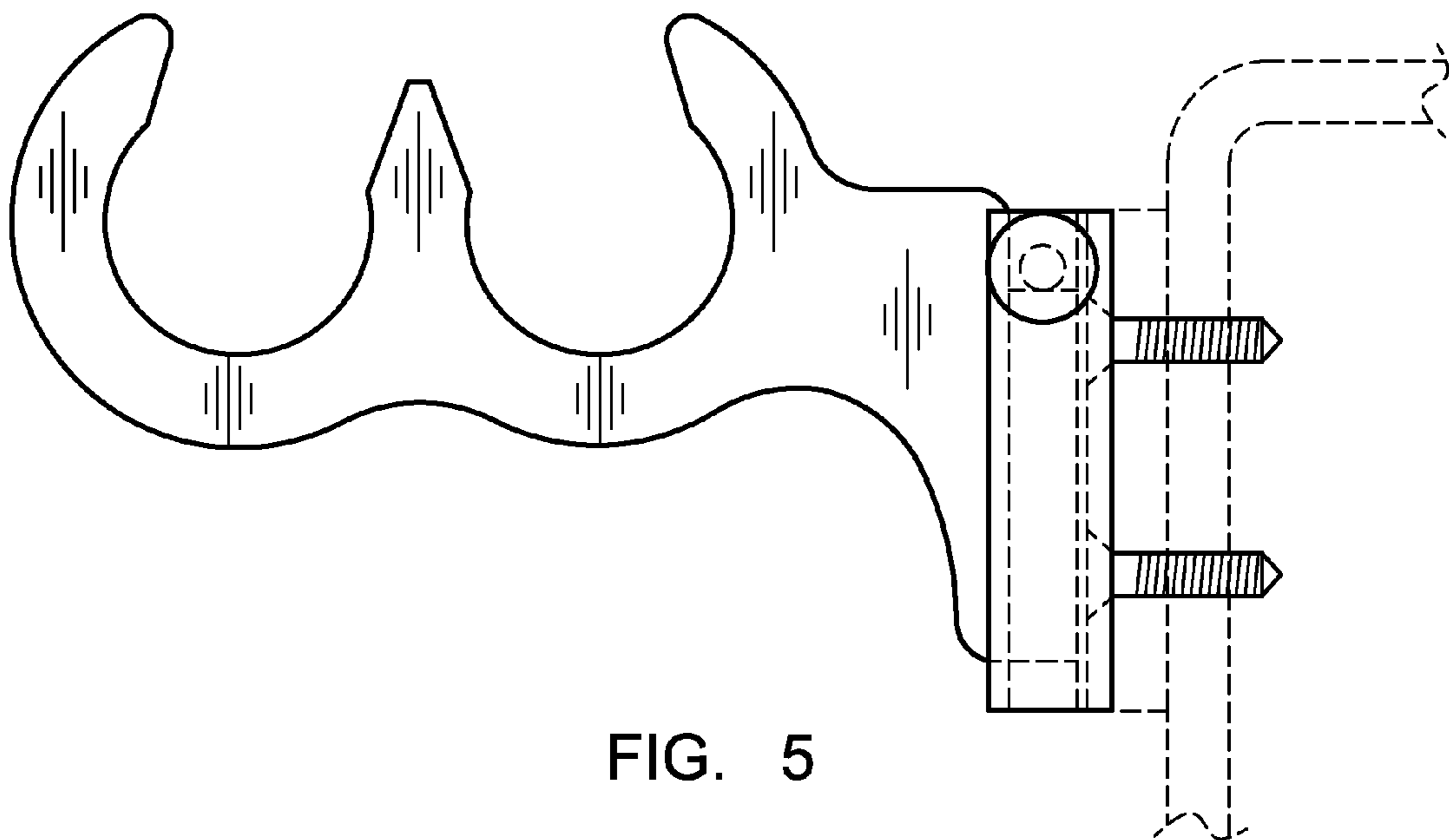

FIG. 5

