



US00D627468S

(12) **United States Design Patent**
Richter et al.

(10) **Patent No.:** **US D627,468 S**

(45) **Date of Patent:** **** Nov. 16, 2010**

(54) **SPINAL IMPLANT**

(75) Inventors: **Marcus Richter**, Wiesbaden (DE);
Farzam Vazifehdan, Traunusstein (DE)

(73) Assignee: **Ulrich GmbH & Co. KG**, Ulm (DE)

(**) Term: **14 Years**

(21) Appl. No.: **29/358,765**

(22) Filed: **Mar. 31, 2010**

6,676,703	B2 *	1/2004	Biscup	623/17.16
6,743,255	B2 *	6/2004	Ferree	623/17.11
6,773,460	B2 *	8/2004	Jackson	623/17.15
6,979,353	B2 *	12/2005	Bresina	623/17.16
D533,277	S *	12/2006	Blain	D24/155
7,169,183	B2 *	1/2007	Liu et al.	623/17.16
D541,940	S *	5/2007	Blain	D24/155
7,309,358	B2 *	12/2007	Berry et al.	623/17.16
7,326,251	B2 *	2/2008	McCombe et al.	623/17.16
7,331,996	B2 *	2/2008	Sato et al.	623/17.16
D566,276	S *	4/2008	Blain	D24/155
7,569,074	B2 *	8/2009	Eisermann et al.	623/17.11
7,641,690	B2 *	1/2010	Abdou	623/17.11

Related U.S. Application Data

(62) Division of application No. 29/329,876, filed on Dec. 23, 2008, now Pat. No. Des. 619,255.

Foreign Application Priority Data

Jul. 26, 2008 (EP) 000959143

(51) **LOC (9) Cl.** **24-03**

(52) **U.S. Cl.** **D24/155**

(58) **Field of Classification Search** D24/155-157;
606/60, 61, 73, 95, 213, 246, 248, 249; 623/23.61,
623/23.56, 247, 213, 11.11, 16.14, 20.23,
623/20.33, 33, 41, 17.11-17.16
See application file for complete search history.

References Cited

U.S. PATENT DOCUMENTS

6,245,108	B1 *	6/2001	Biscup	623/17.11
6,432,140	B1 *	8/2002	Lin	623/17.16
6,491,724	B1 *	12/2002	Ferree	623/17.11
D472,632	S *	4/2003	Anderson	D24/155
6,610,093	B1 *	8/2003	Pisharodi	623/17.15

* cited by examiner

Primary Examiner—Charles A Rademaker

(74) *Attorney, Agent, or Firm*—Andrew Wilford

(57) **CLAIM**

The ornamental design for a spinal implant, as shown and described.

DESCRIPTION

FIG. 1 is a front perspective view of a spinal implant showing our new design;

FIG. 2 is a top plan view thereof shown on an enlarged scale, the bottom being identical;

FIG. 3 is a right side elevation thereof, the side opposite being identical;

FIG. 4 is a front elevation thereof shown on an enlarges scale; and,

FIG. 5 is a rear elevation thereof.

1 Claim, 5 Drawing Sheets

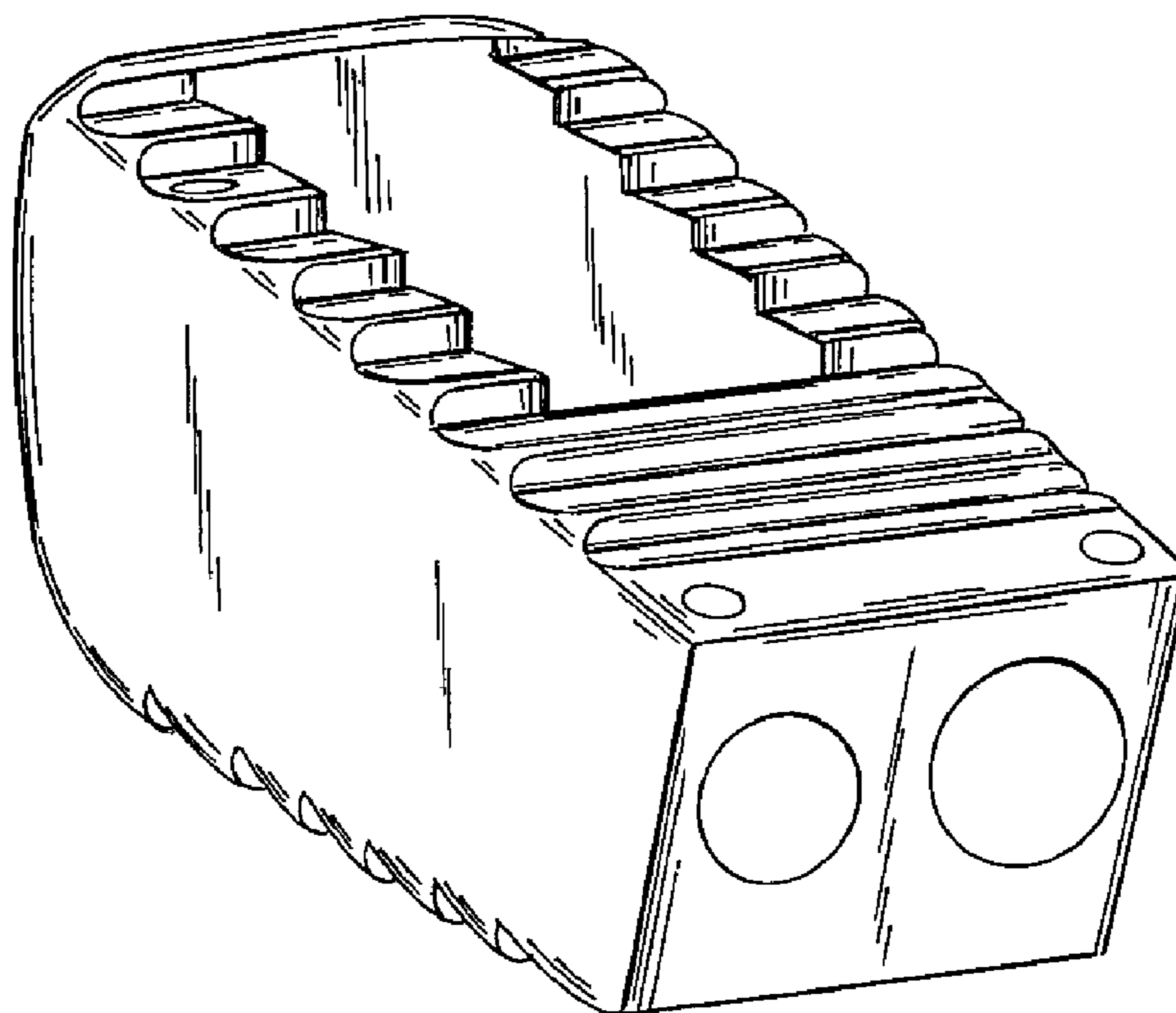

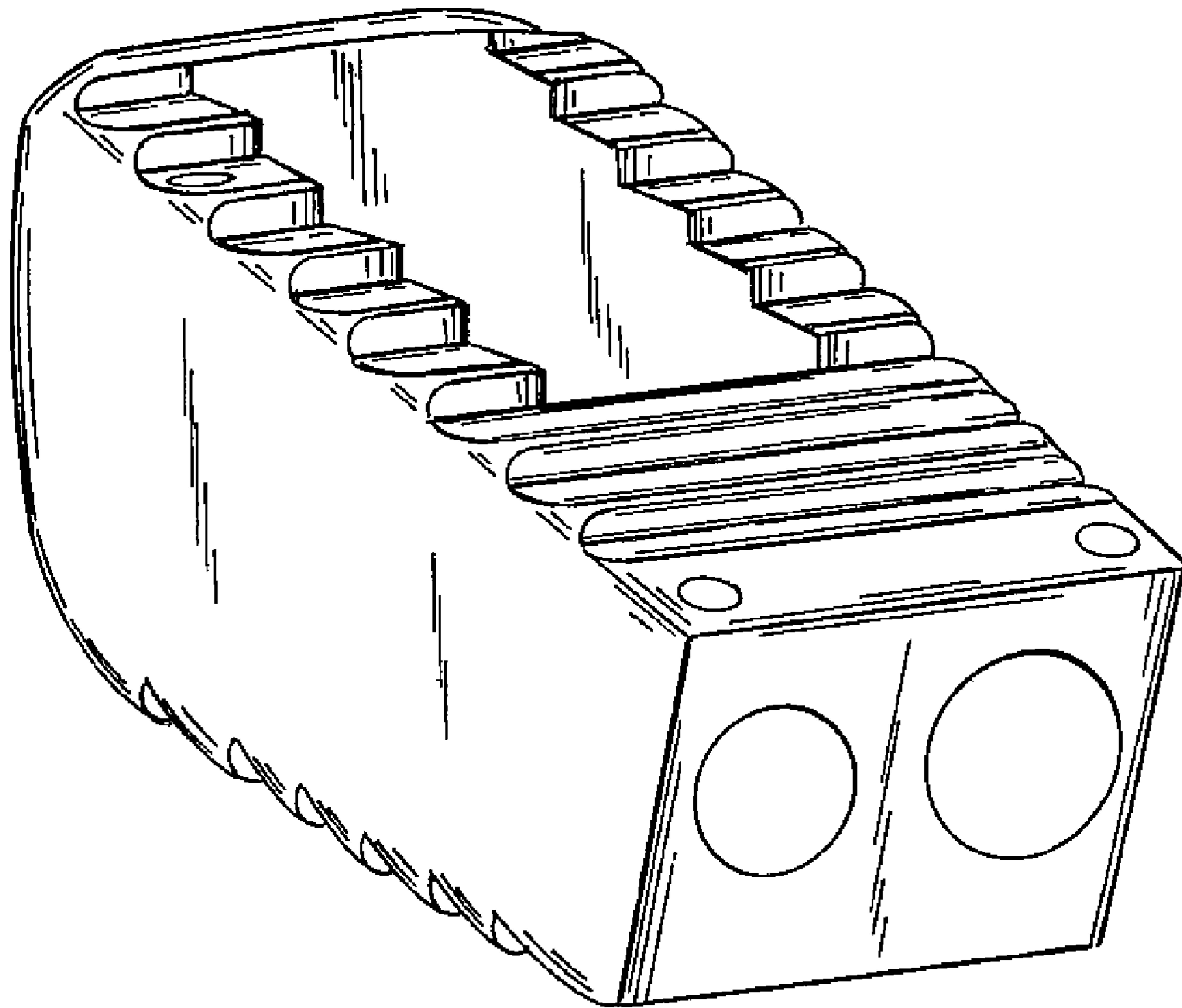

FIG.1

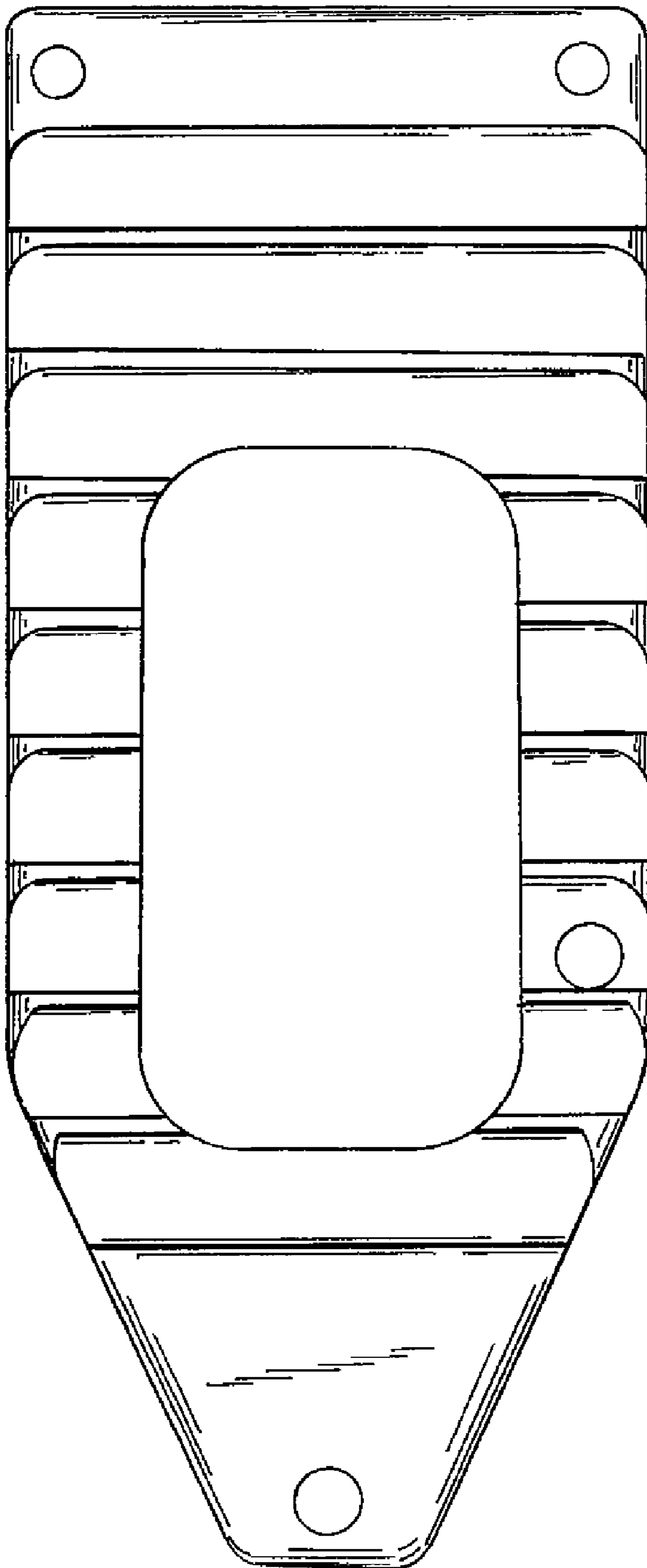

FIG.2

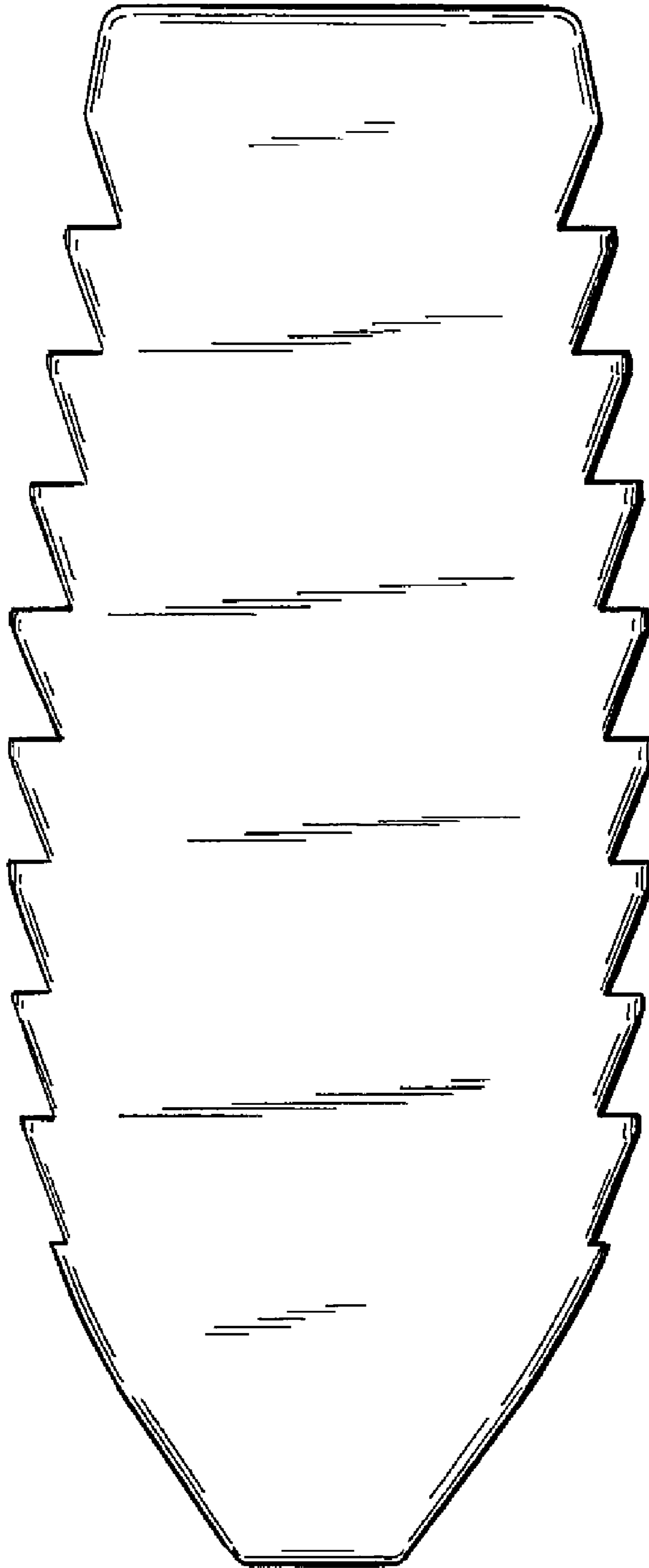

FIG.3

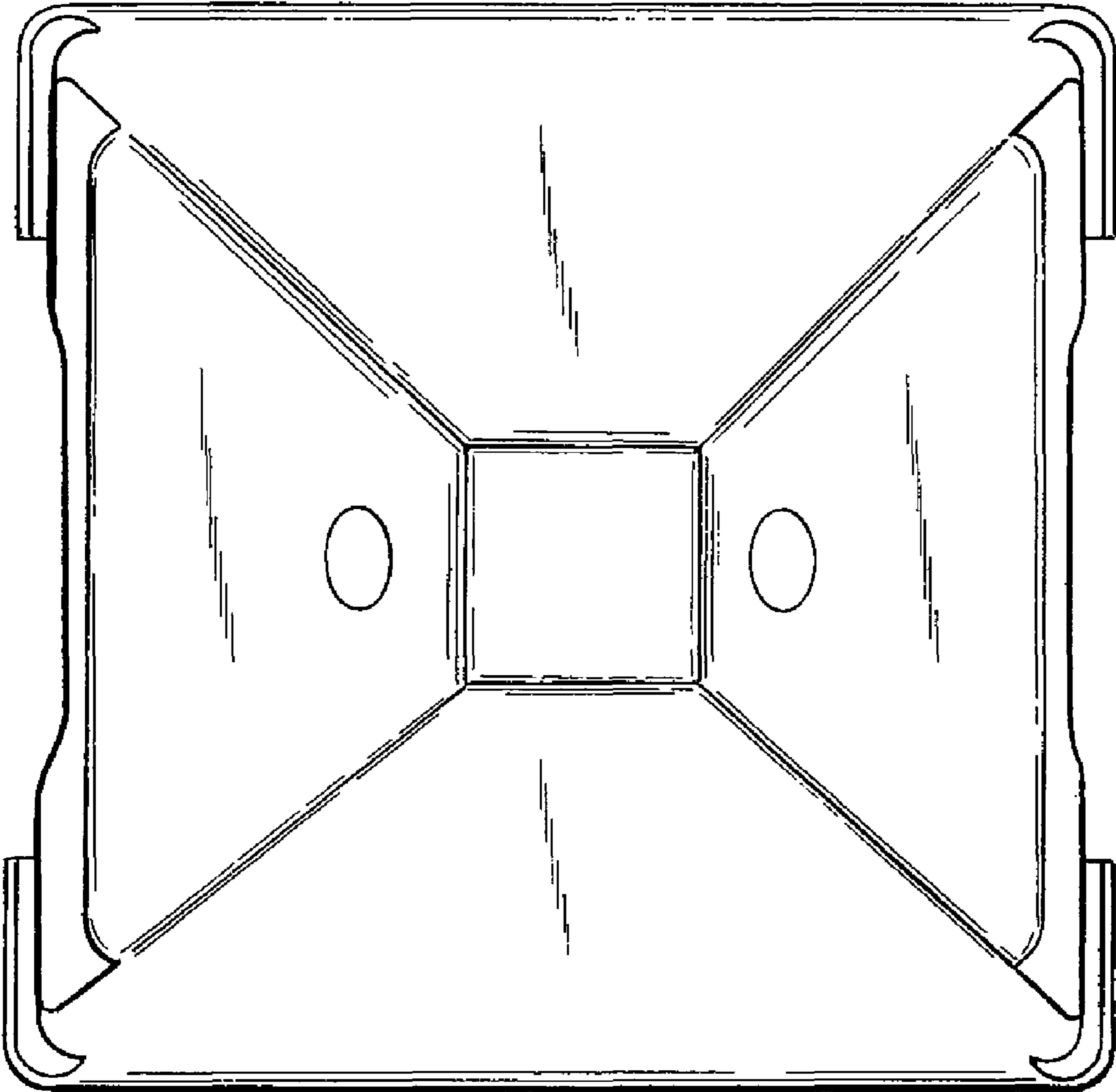

FIG.4

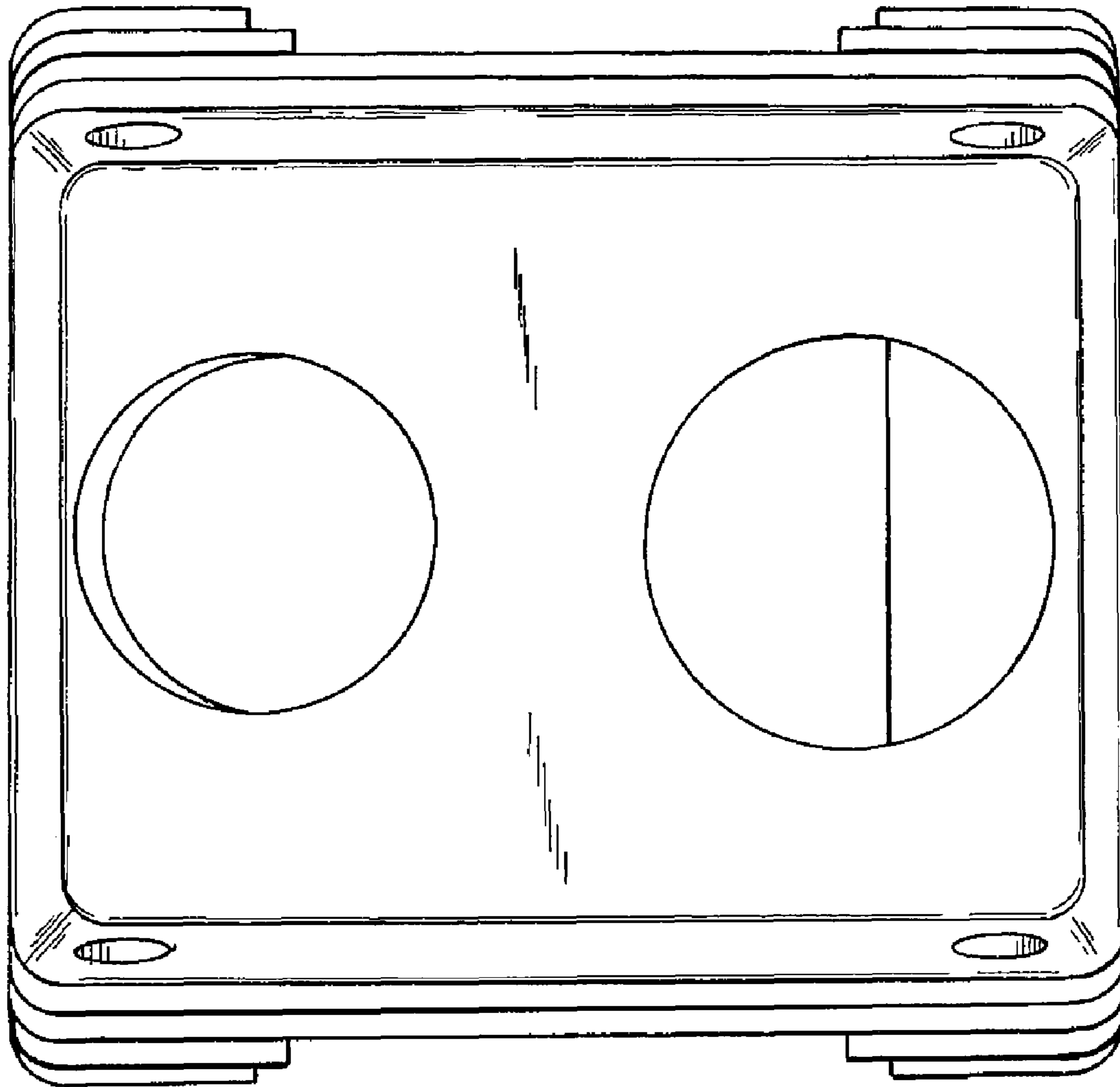

FIG.5