



US00D627280S

(12) **United States Design Patent**  
**Sharma et al.**

(10) **Patent No.:** **US D627,280 S**  
(45) **Date of Patent:** **\*\* Nov. 16, 2010**

(54) **BUMPER FOR A VEHICLE**

(75) Inventors: **Navendu Sharma**, Naperville, IL (US);  
**Jeffrey Russell Zawacki**, Channahon,  
IL (US); **Gary Donald Smith**,  
Shorewood, IL (US)

(73) Assignee: **Hendrickson USA, L.L.C.**, Itasca, IL  
(US)

(\*\*) Term: **14 Years**

(21) Appl. No.: **29/357,188**

(22) Filed: **Mar. 9, 2010**

(51) **LOC (9) Cl.** ..... **12-16**

(52) **U.S. Cl.** ..... **D12/169**

(58) **Field of Classification Search** ..... D12/169,  
D12/196, 90-92; 293/102, 105, 113, 115,  
293/117, 120; 296/180.1, 180.2

See application file for complete search history.

(56) **References Cited**

**U.S. PATENT DOCUMENTS**

D400,144 S 10/1998 Hellhake et al.

(Continued)

*Primary Examiner*—Melody N Brown

(74) *Attorney, Agent, or Firm*—McDonnell Boehnen  
Hulbert & Berghoff, LLP

(57) **CLAIM**

The ornamental design for a bumper for a vehicle, as shown  
and described.

**DESCRIPTION**

FIG. 1 is a perspective view showing the front, the front left  
side, the rear right side, and the top of a bumper for a vehicle  
showing my design;

FIG. 2 is a front elevational view of the bumper for a vehicle  
shown in FIG. 1;

FIG. 3 is a rear elevational view of the bumper for a vehicle  
shown in FIG. 1;

FIG. 4 is a right side elevational view of the bumper for a  
vehicle shown in FIG. 1;

FIG. 5 is a left side elevational view of the bumper for a  
vehicle shown in FIG. 1;

FIG. 6 is a top plan view of the bumper for a vehicle shown in  
FIG. 1;

FIG. 7 is a bottom plan view of the bumper for a vehicle  
shown in FIG. 1;

FIG. 8 is a perspective view showing the rear and the bottom  
of the bumper for a vehicle shown in FIG. 1;

FIG. 9 is a perspective view showing the front left side, the  
rear, and the bottom of the bumper for a vehicle shown in FIG.  
1;

FIG. 10 is a perspective view showing the rear, the bottom,  
and front right side of the bumper for a vehicle shown in FIG.  
1;

FIG. 11 is a perspective view showing the top, the rear, and the  
front left side of the bumper for a vehicle shown in FIG. 1;

FIG. 12 is a perspective view showing the top and the rear of  
the bumper for a vehicle shown in FIG. 1;

FIG. 13 is a perspective view showing the top, the rear, and the  
front left side of the bumper for a vehicle shown in FIG. 1;

FIG. 14 is a perspective view showing the top, the rear, and the  
front right side of the bumper for a vehicle shown in FIG. 1;

FIG. 15 is a perspective view showing the bottom, the front  
right side, and the rear left side of the bumper for a vehicle  
shown in FIG. 1;

FIG. 16 is a perspective view showing the top and the front of  
the bumper for a vehicle shown in FIG. 1;

FIG. 17 is a perspective view showing the front and the  
bottom of the bumper for a vehicle shown in FIG. 1;

FIG. 18 is a perspective view showing the top, the rear, and the  
front right side of the bumper for a vehicle shown in FIG. 1;  
and,

FIG. 19 is a perspective view showing the front, the front left  
side, the rear right side, and the bottom of the bumper for a  
vehicle shown in FIG. 1.

**1 Claim, 19 Drawing Sheets**

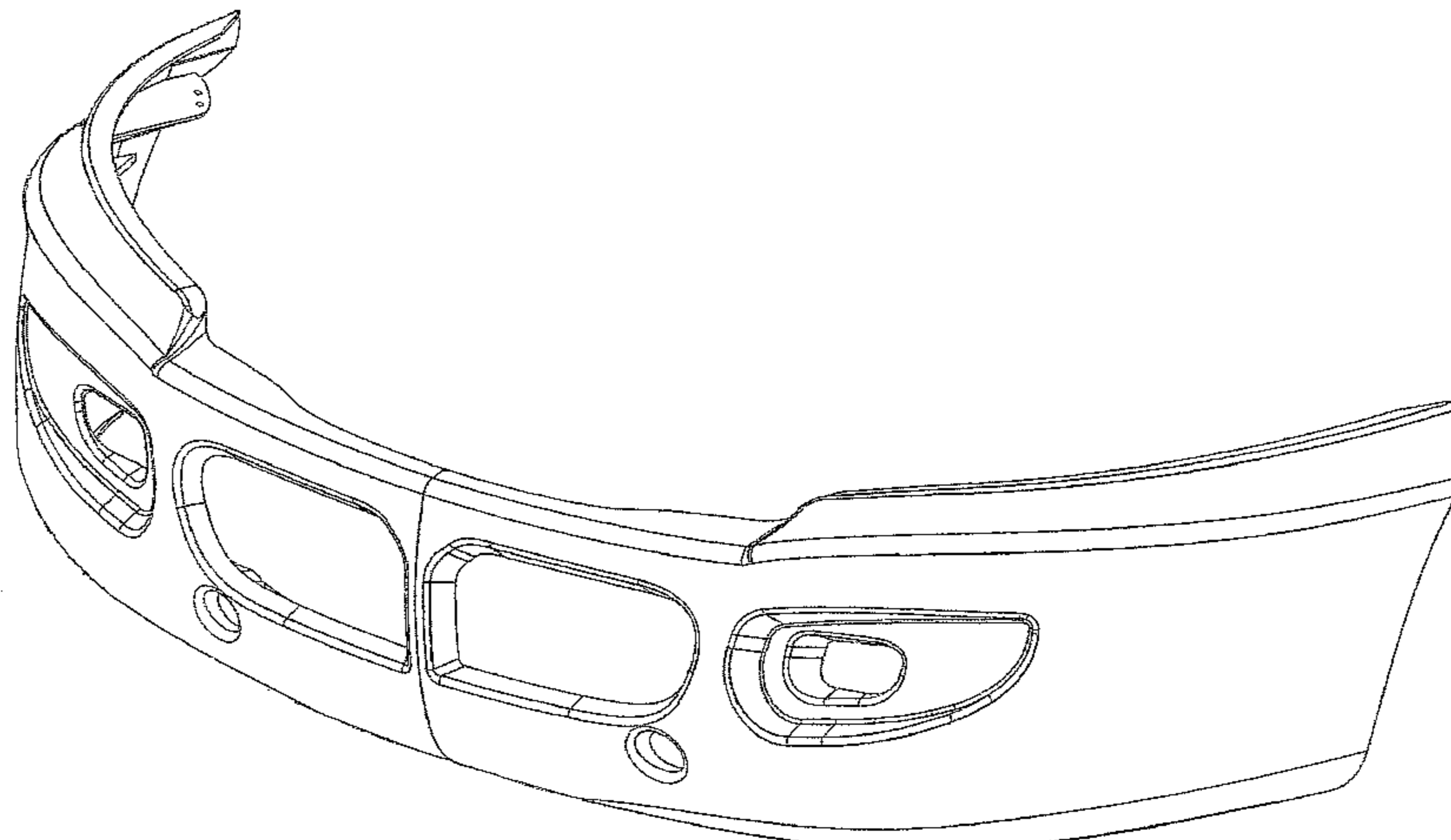

# US D627,280 S

Page 2

---

## U.S. PATENT DOCUMENTS

D403,636 S	1/1999	Meryman et al.	D521,912 S	5/2006	Beigel et al.
D411,494 S	6/1999	Meryman et al.	D530,653 S	10/2006	Angelo et al.
D418,095 S	12/1999	Reitnouer	D531,940 S	11/2006	McCuller et al.
D419,506 S	1/2000	Texier et al.	D535,225 S	1/2007	Tsai
D420,634 S	2/2000	Nelson	D535,231 S *	1/2007	Otsubo et al. .... D12/169
D423,429 S	4/2000	Hickman et al.	D537,389 S	2/2007	Beigel et al.
D429,669 S	8/2000	Cook et al.	D540,224 S	4/2007	Gregory et al.
D442,898 S	5/2001	Beigel	D540,722 S	4/2007	Angelo et al.
D475,663 S *	6/2003	Chiang ..... D12/169	D551,136 S *	9/2007	Manfredini ..... D12/169
D476,929 S	7/2003	Dozier et al.	D556,649 S	12/2007	Beigel et al.
D482,302 S	11/2003	Dozier et al.	D556,653 S *	12/2007	Leclercq ..... D12/169
D497,335 S	10/2004	Bird et al.	D563,840 S	3/2008	Simons et al.
D504,850 S	5/2005	Gunter et al.	D565,484 S	4/2008	Johnson et al.

\* cited by examiner

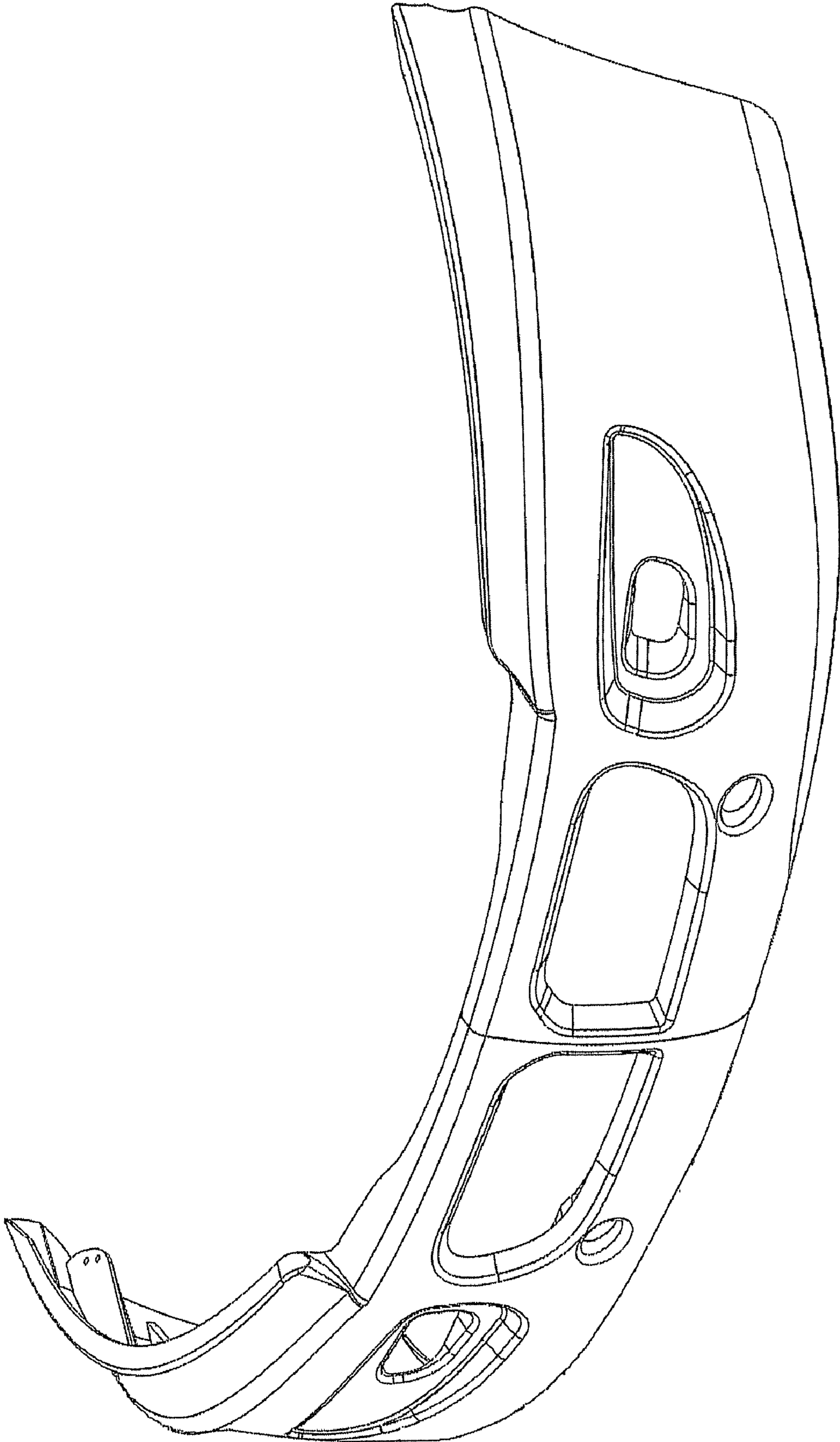

FIG. 1

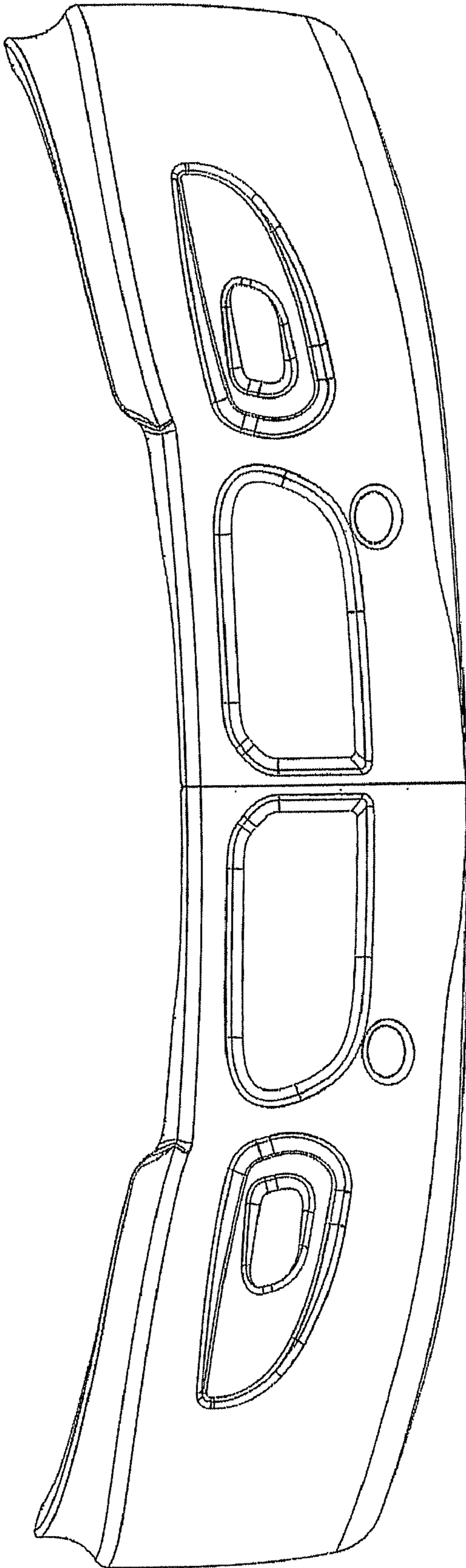

FIG. 2

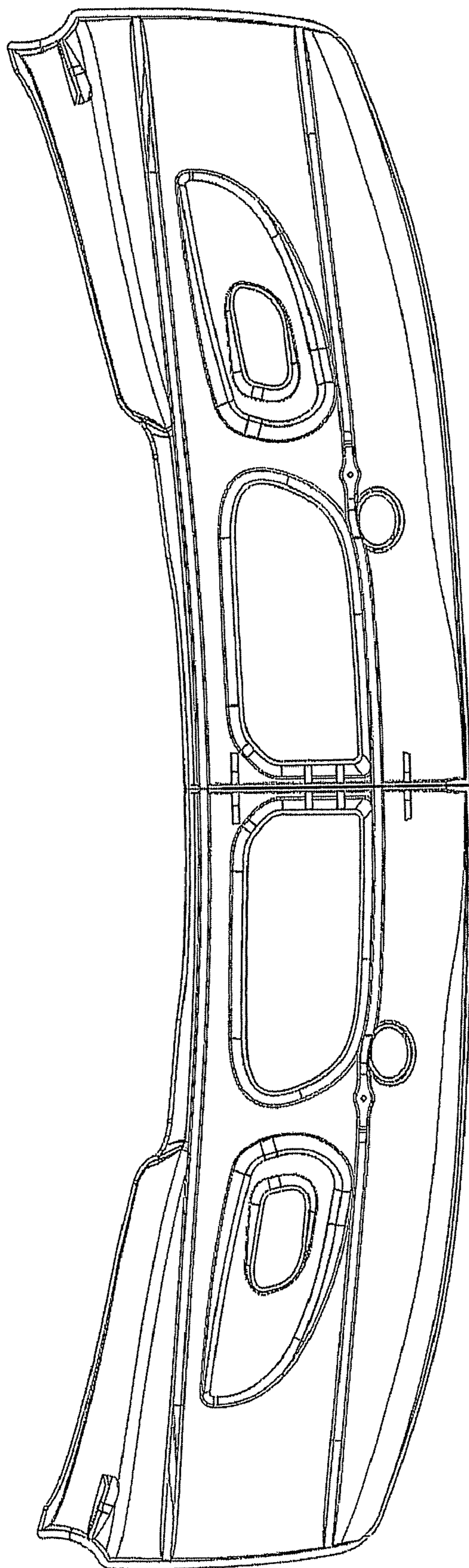

FIG. 3

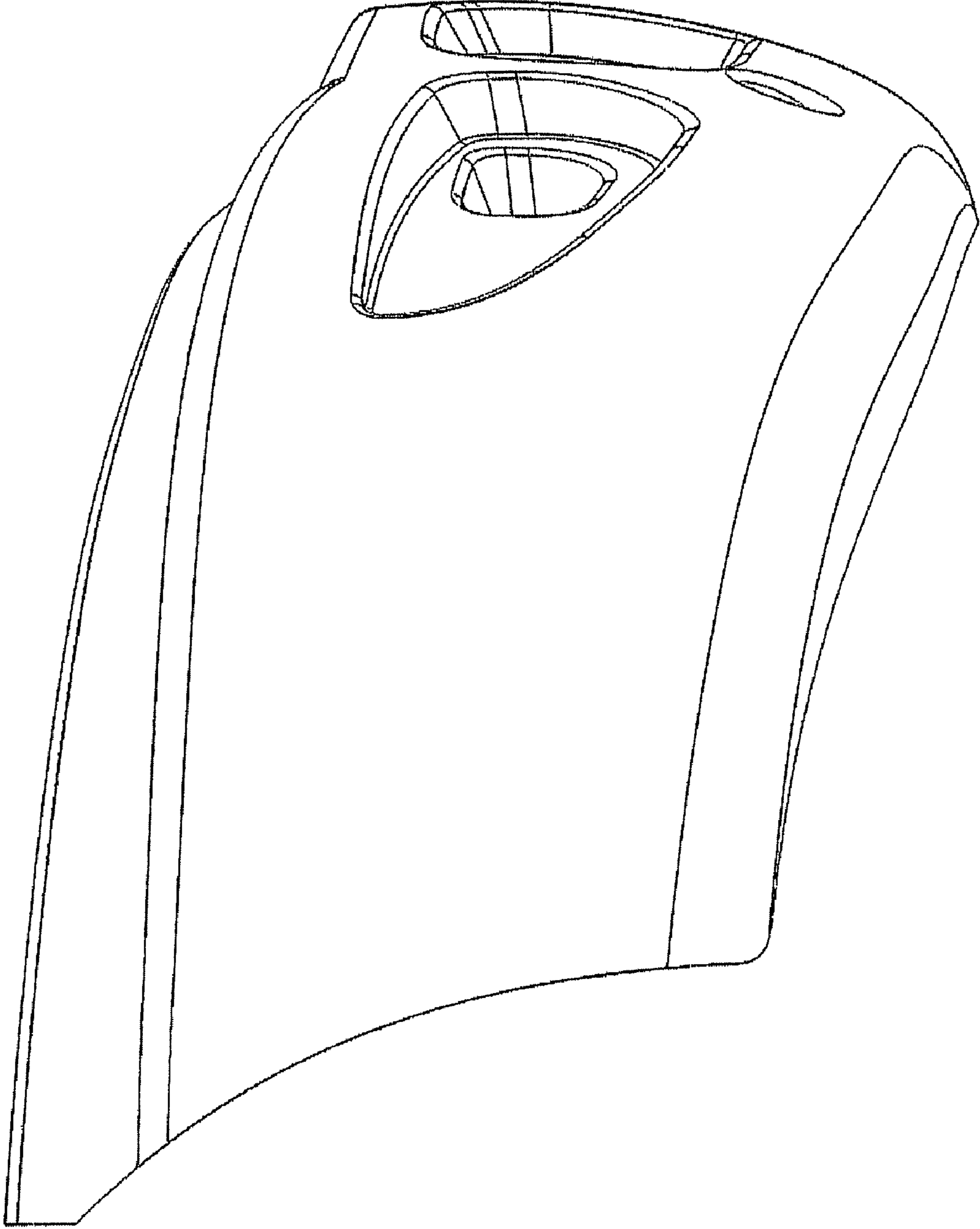

FIG. 4

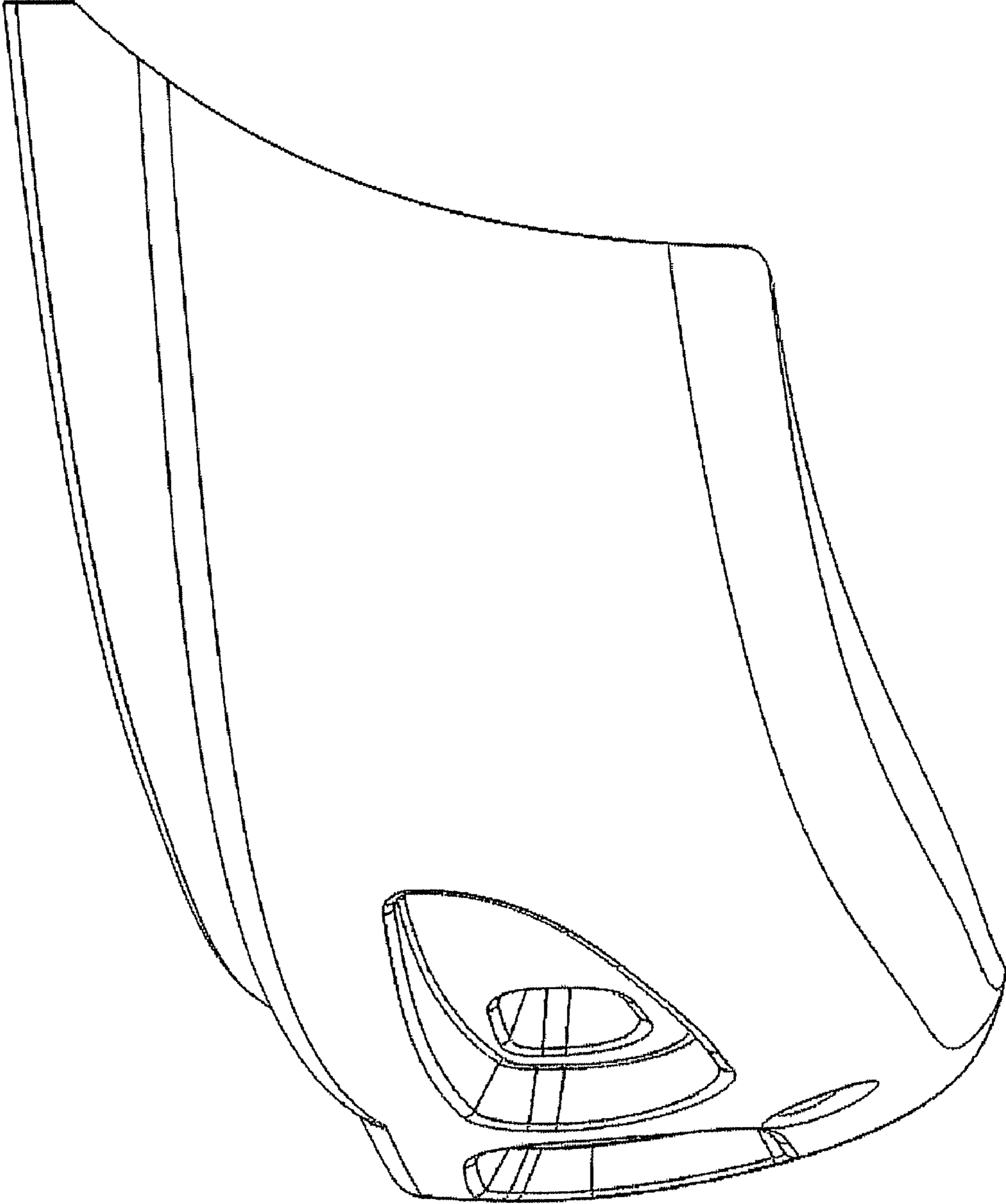

FIG. 5

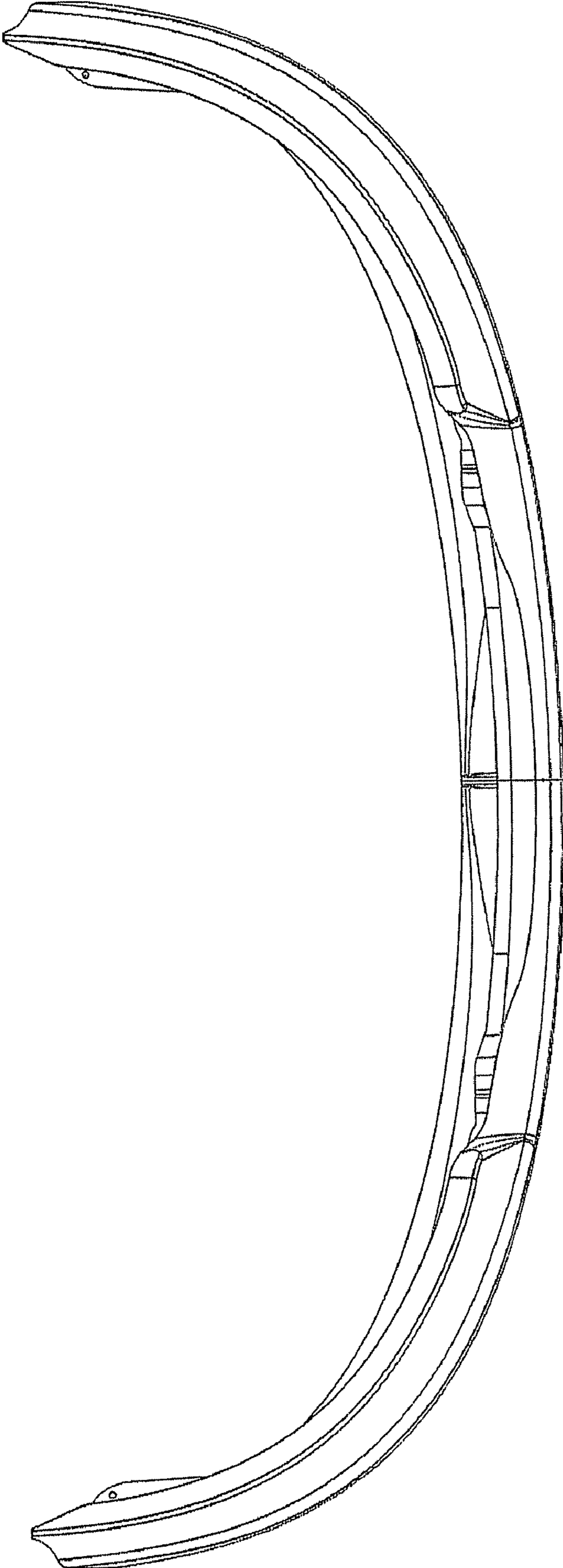

FIG. 6



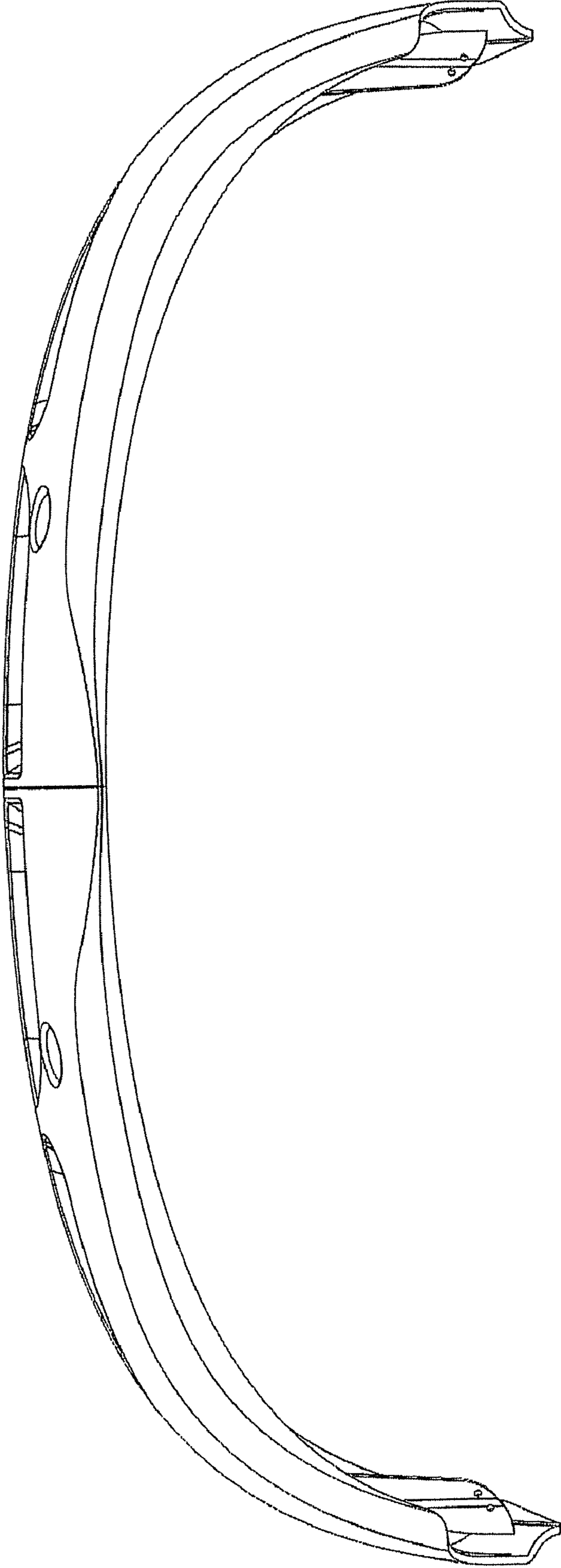

FIG. 7

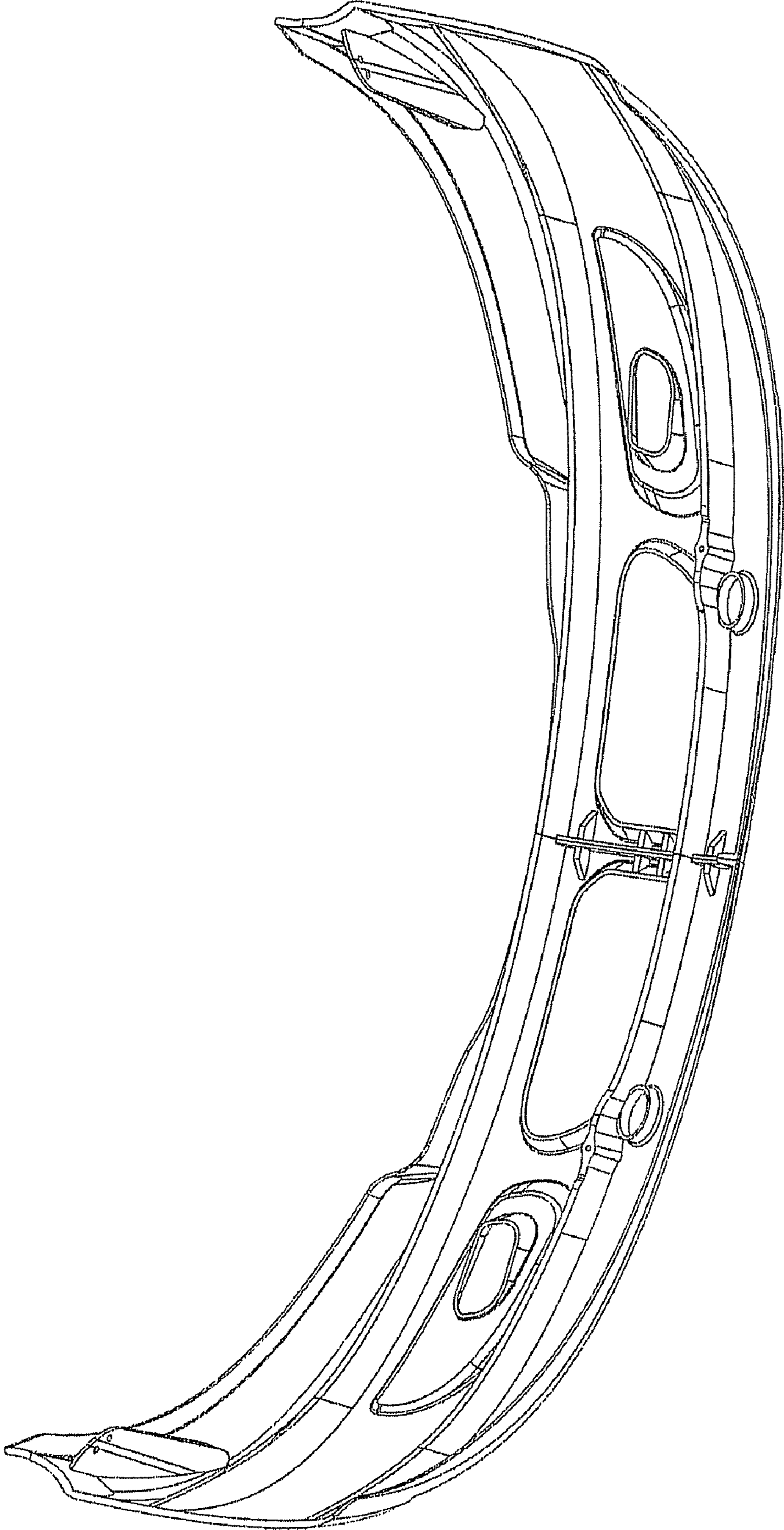

FIG. 8

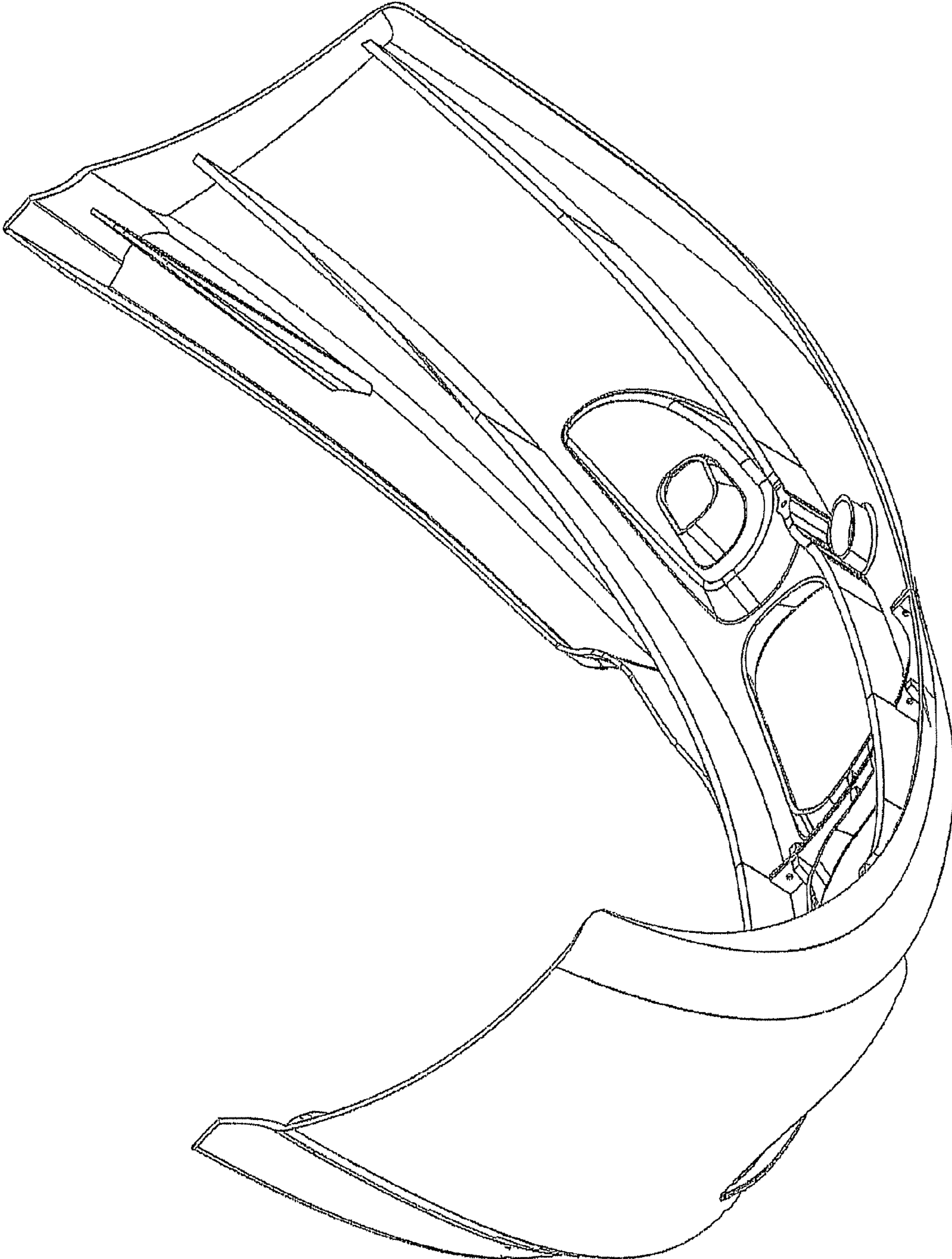

FIG. 9

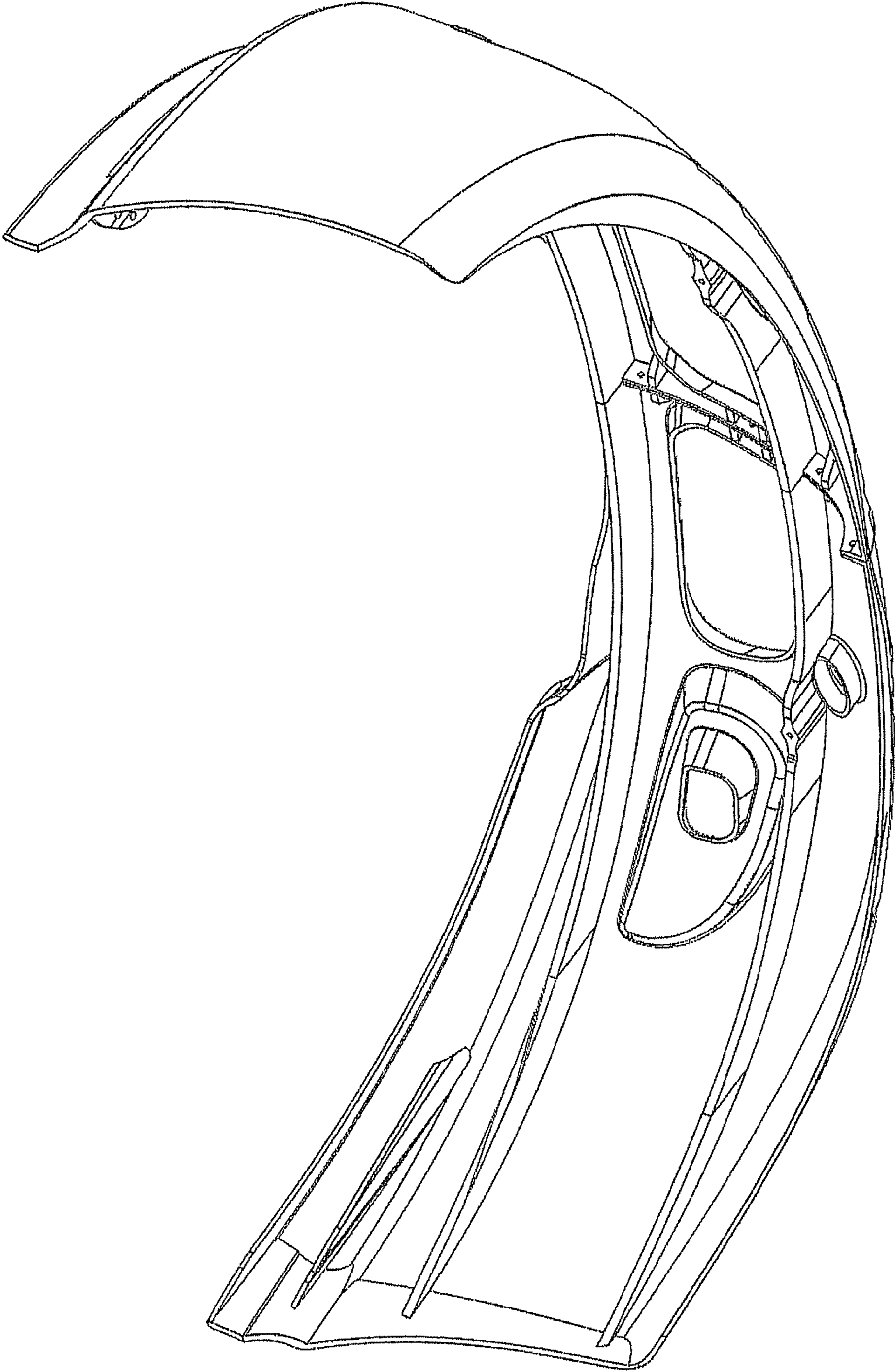

FIG. 10

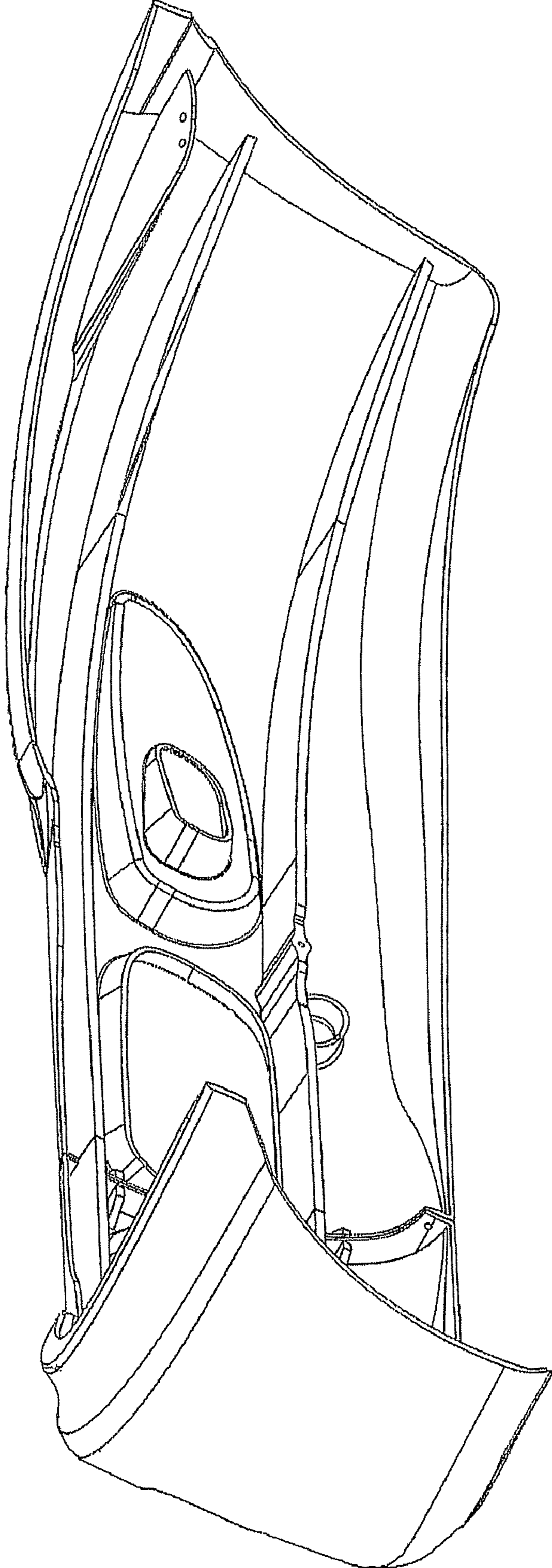

FIG. 11

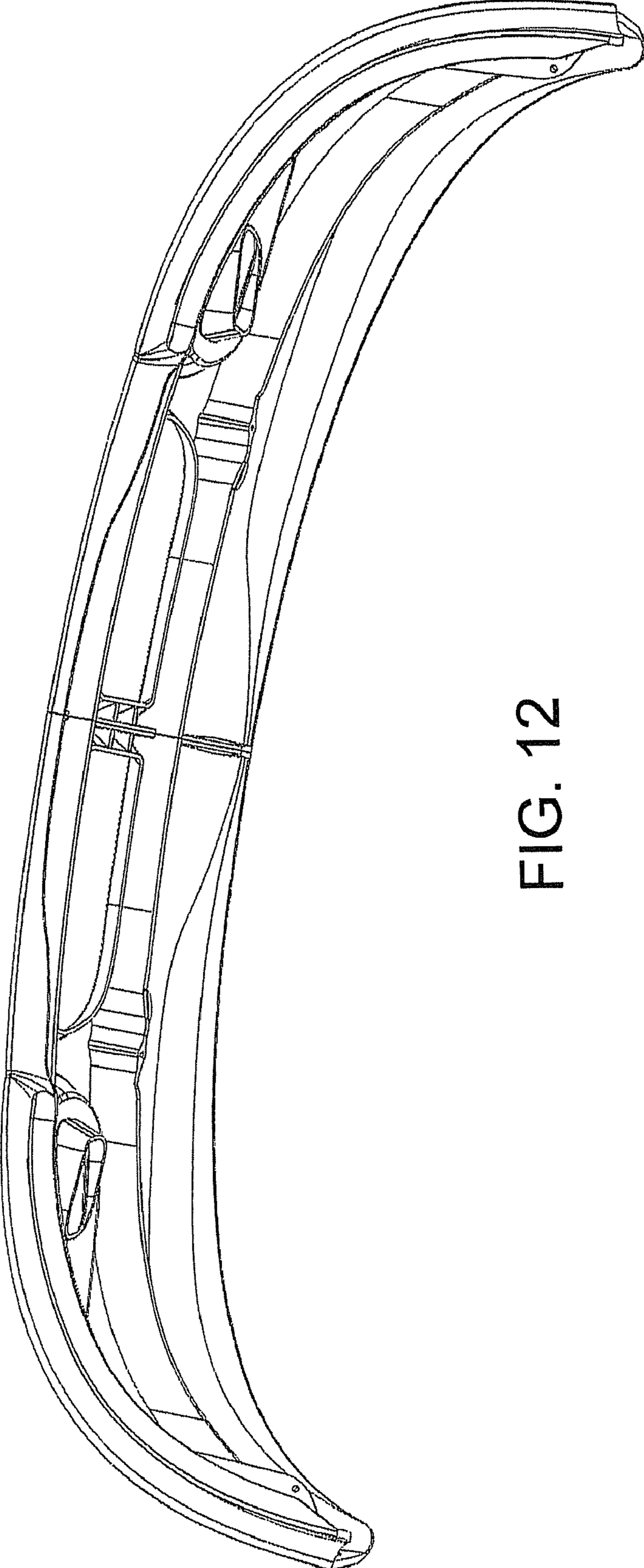

FIG. 12

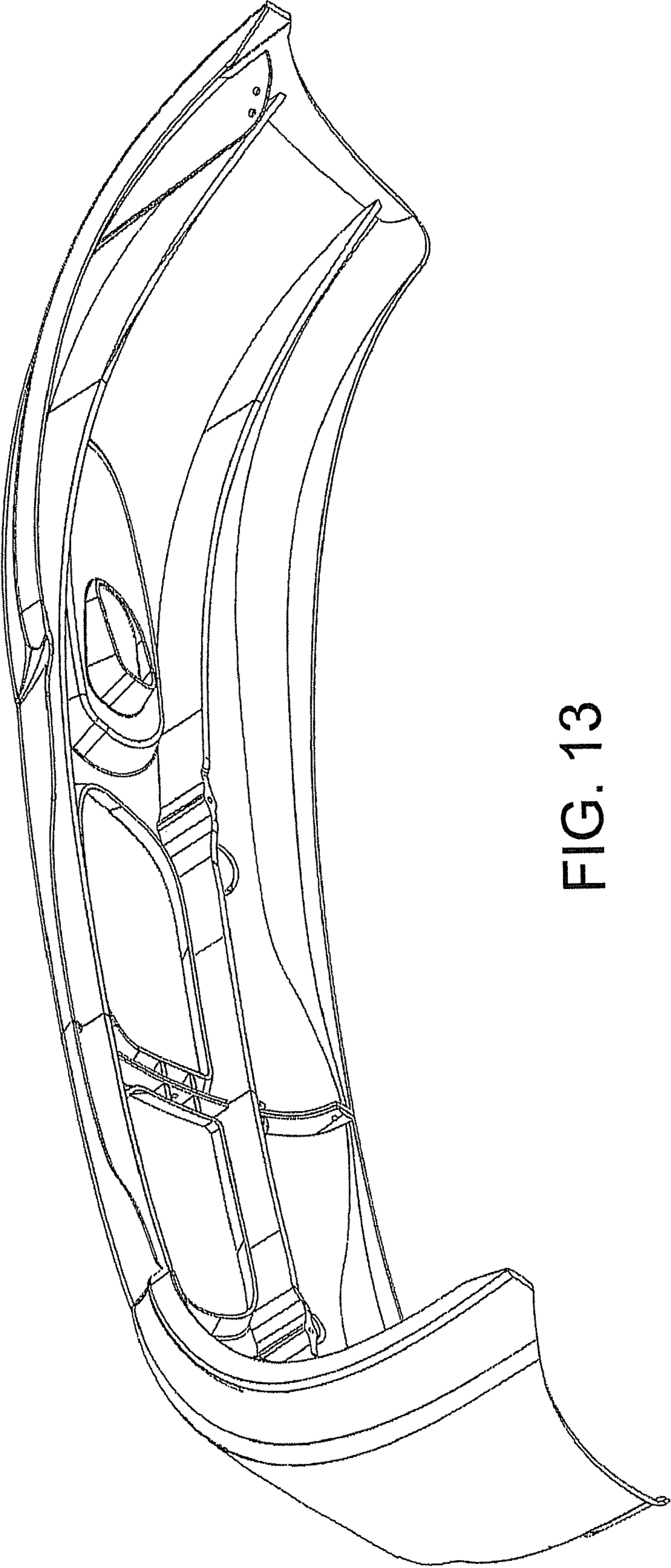

FIG. 13

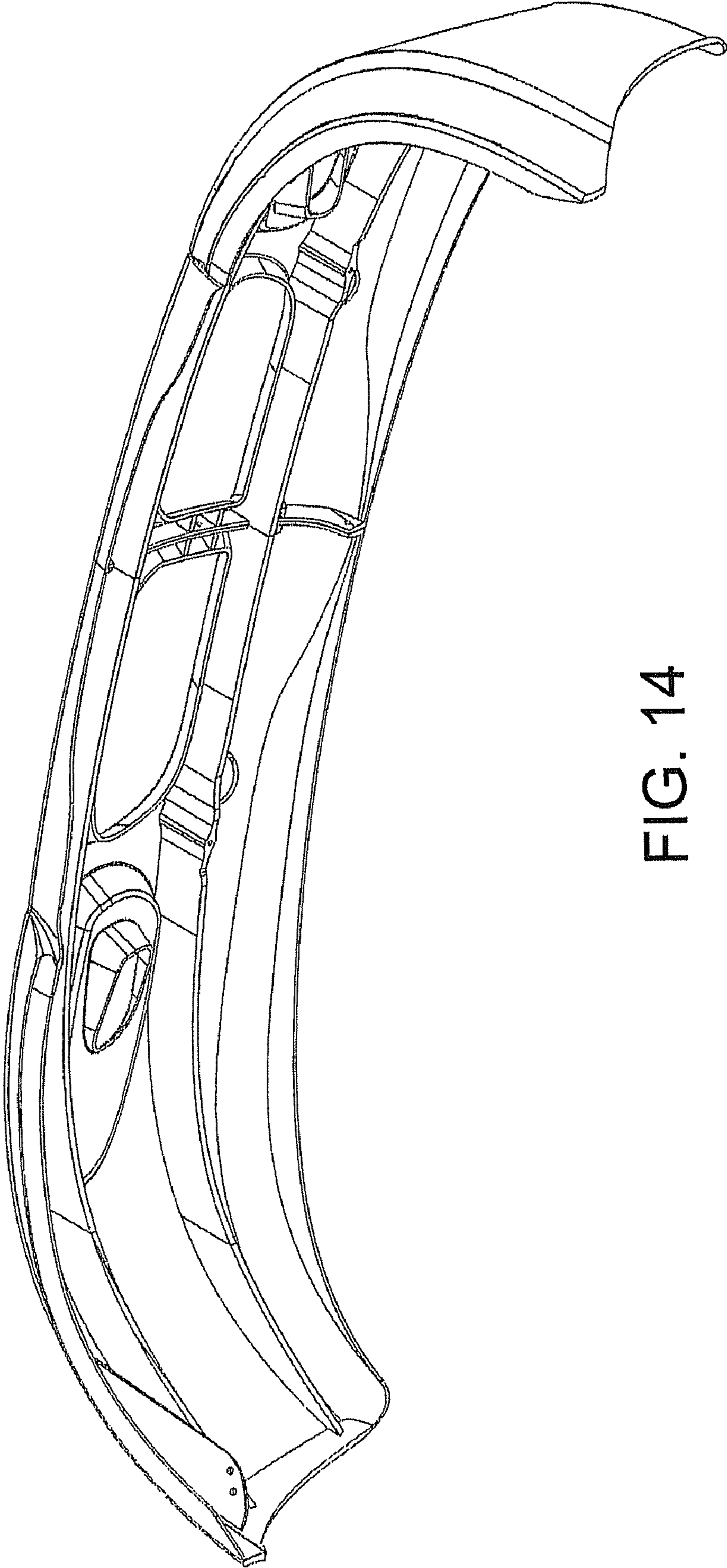

FIG. 14



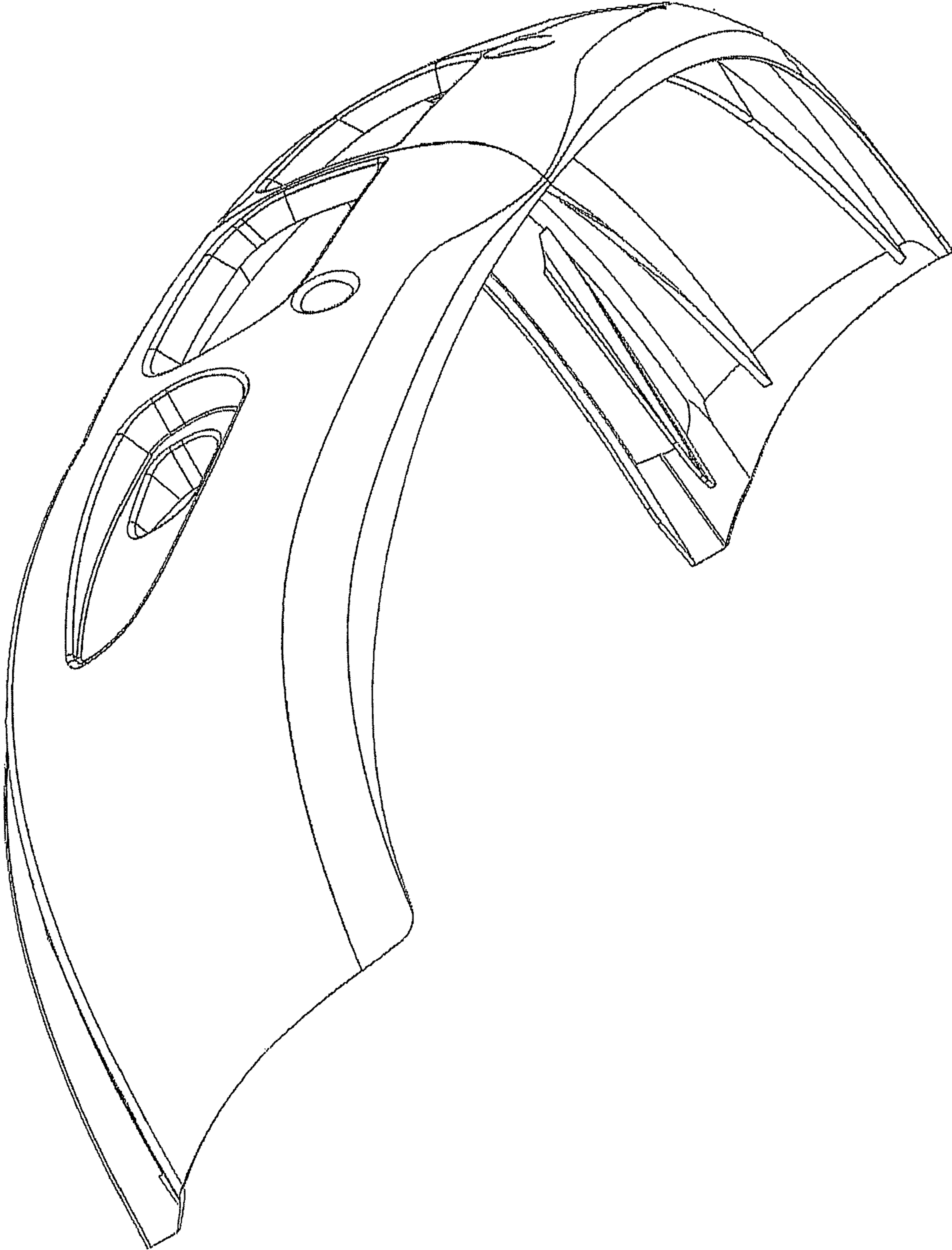

FIG. 15

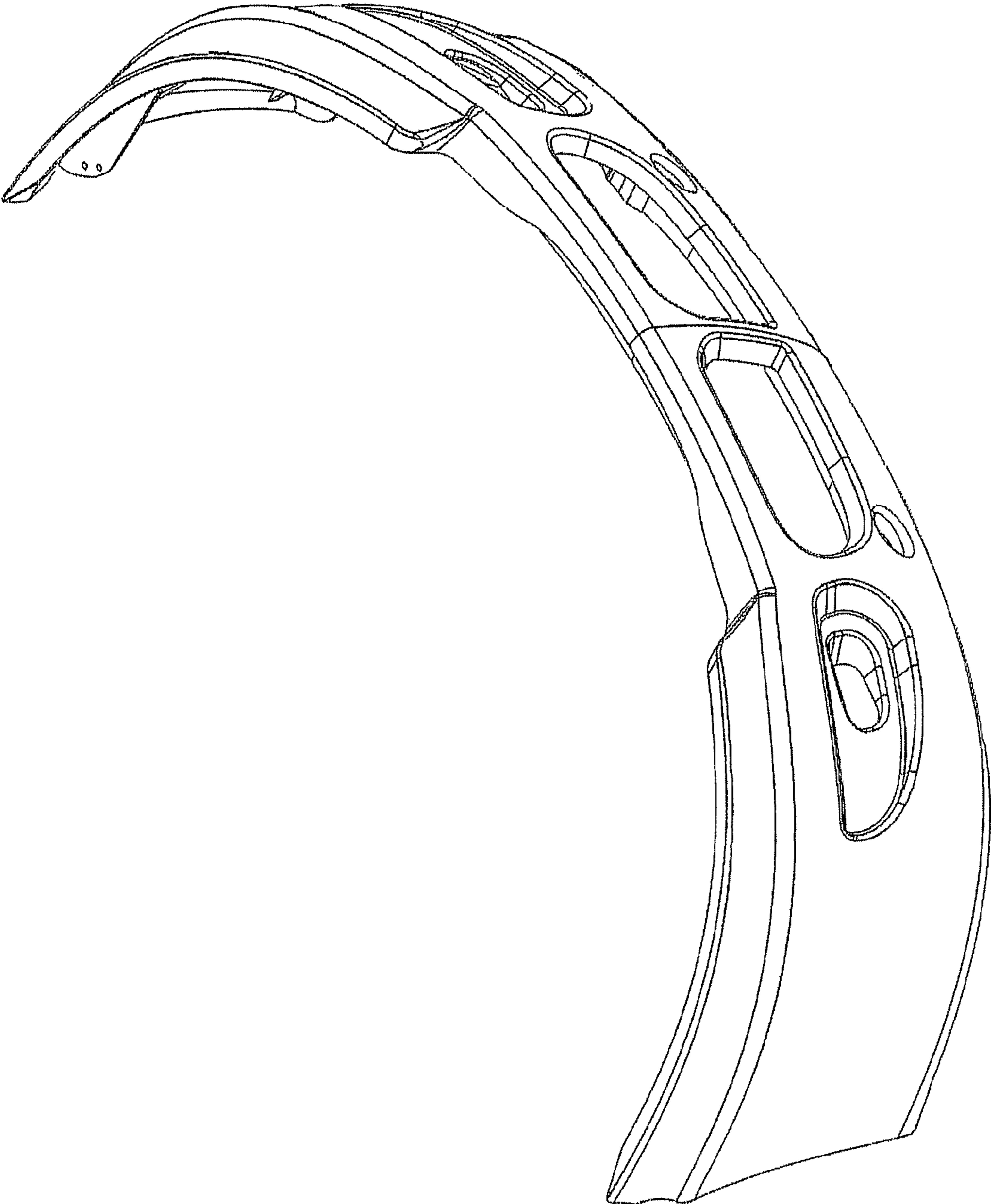

FIG. 16

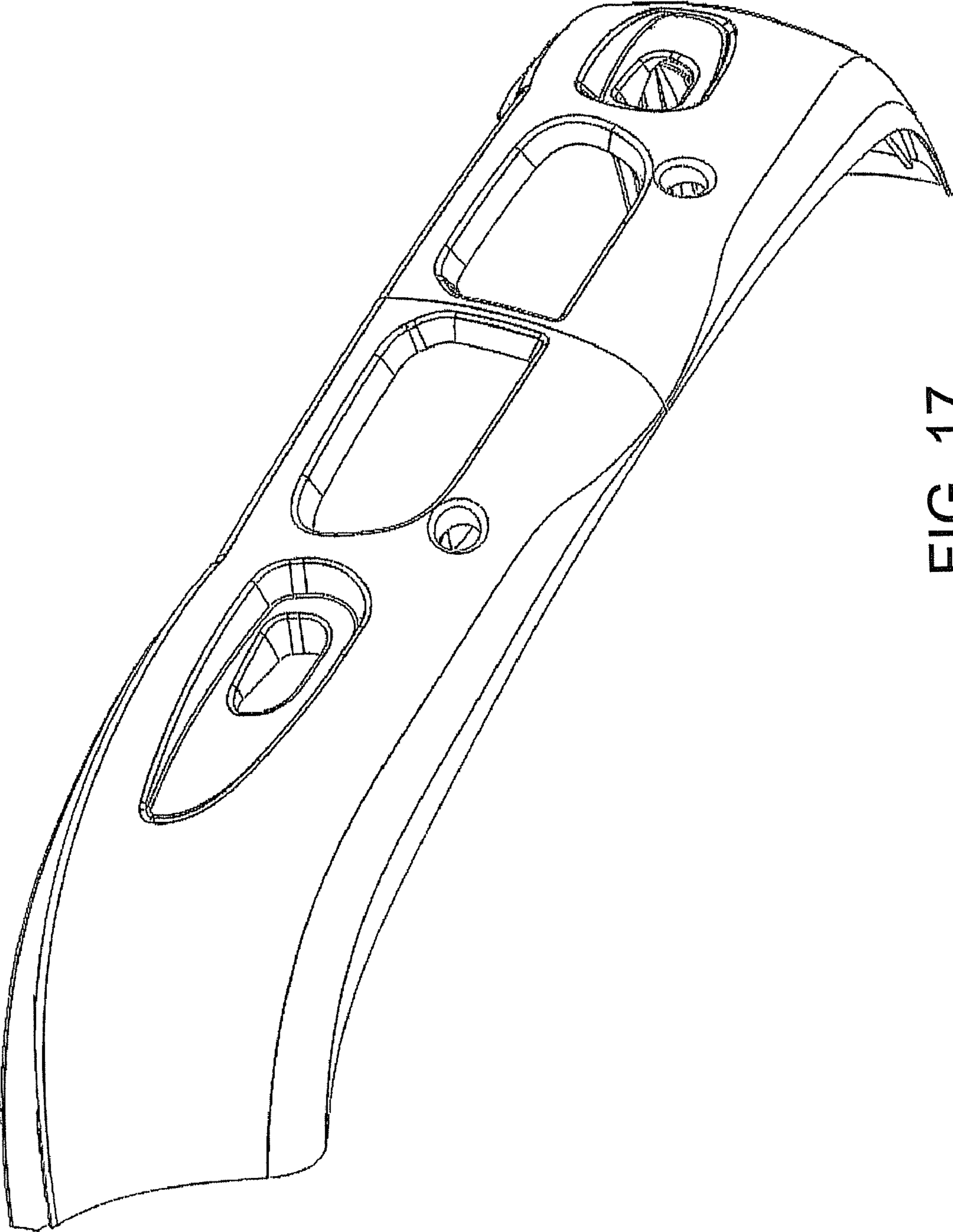

FIG. 17

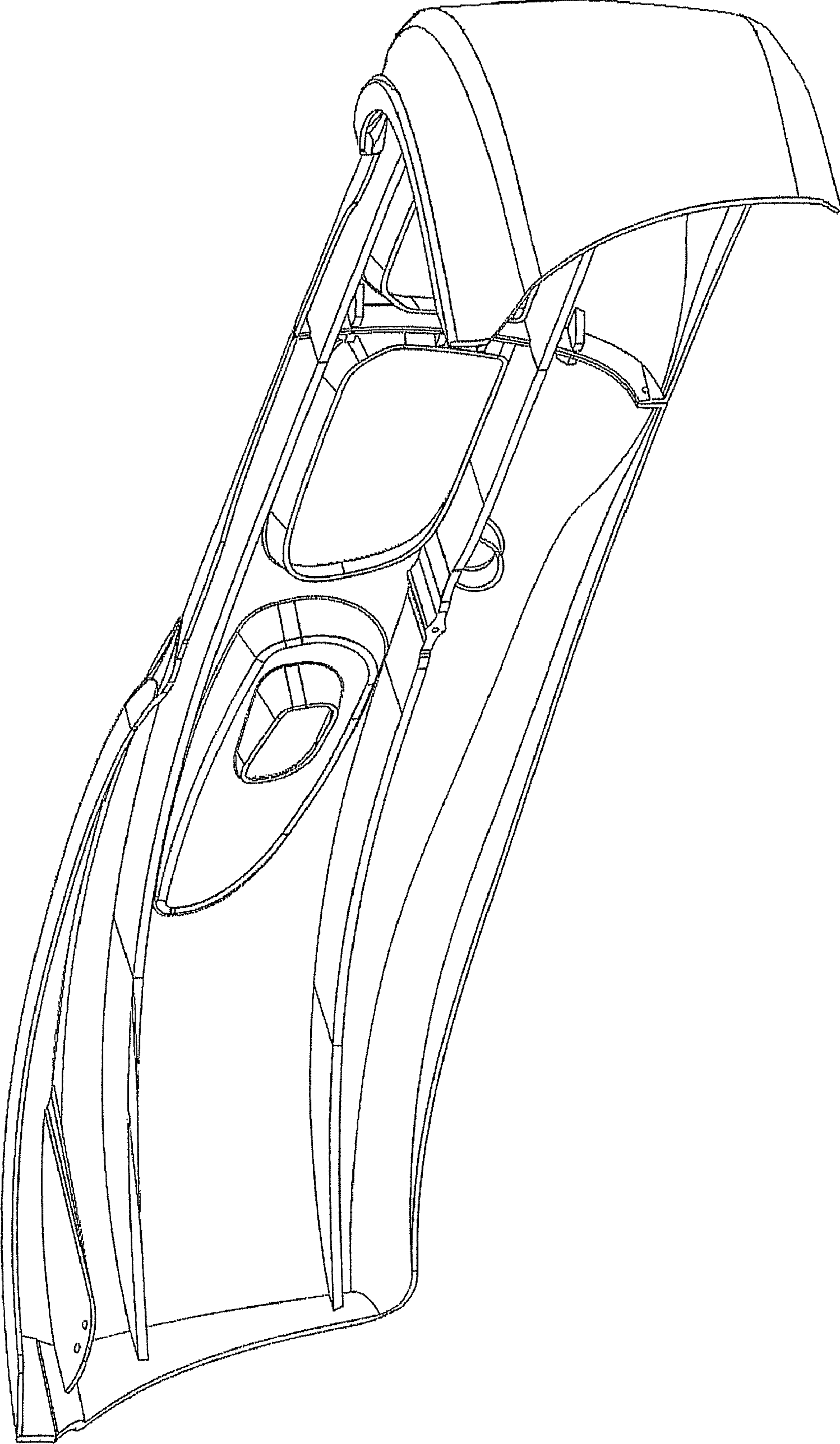

FIG. 18



FIG. 19