



US00D627118S

(12) **United States Design Patent**  
**Bensussan et al.**

(10) **Patent No.:** **US D627,118 S**  
(45) **Date of Patent:** **\*\* Nov. 9, 2010**

(54) **CONNECTING ASSEMBLY FOR TOOLS AND HANDLES**

(75) Inventors: **Bernard Bensussan**, Monroe, CT (US);  
**Bruno Gabriel Niklaus**, Cos Cob, CT (US)

(73) Assignee: **Unger Marketing International, LLC**,  
Bridgeport, CT (US)

(\*\*) Term: **14 Years**

(21) Appl. No.: **29/315,719**

(22) Filed: **Jul. 17, 2009**

(51) **LOC (9) Cl.** ..... **04-01**

(52) **U.S. Cl.** ..... **D32/41; D32/50**

(58) **Field of Classification Search** ..... D32/40-45,  
D32/50; 15/244.2, 245; D8/321; 403/374.1;  
401/137, 138

See application file for complete search history.

(56) **References Cited**

**U.S. PATENT DOCUMENTS**

D564,161 S \* 3/2008 Talesfore et al. .... D32/41  
7,618,206 B2 \* 11/2009 Sacks ..... 401/138

\* cited by examiner

*Primary Examiner*—Robin V Webster  
(74) *Attorney, Agent, or Firm*—Ohlandt, Greeley, Ruggiero & Perle, L.L.P.

(57) **CLAIM**

The ornamental design for the connecting assembly for tools and handles, as shown and described.

**DESCRIPTION**

FIG. 1 is a perspective view of a connecting assembly for tools and handles according to an exemplary embodiment of the present disclosure;

FIG. 2 is a front view of the connecting assembly of FIG. 1;

FIG. 3 is a rear view of the connecting assembly of FIG. 1;

FIG. 4 is a first end view of the connecting assembly of FIG. 1;

FIG. 5 is a second, opposite end view of the connecting assembly of FIG. 1; and,

FIG. 6 is a side view of the connecting assembly of FIG. 1, the opposite side being identical thereto.

The broken lines in the drawings illustrating environmental structure or boundaries that form no part of the claimed design.

**1 Claim, 5 Drawing Sheets**

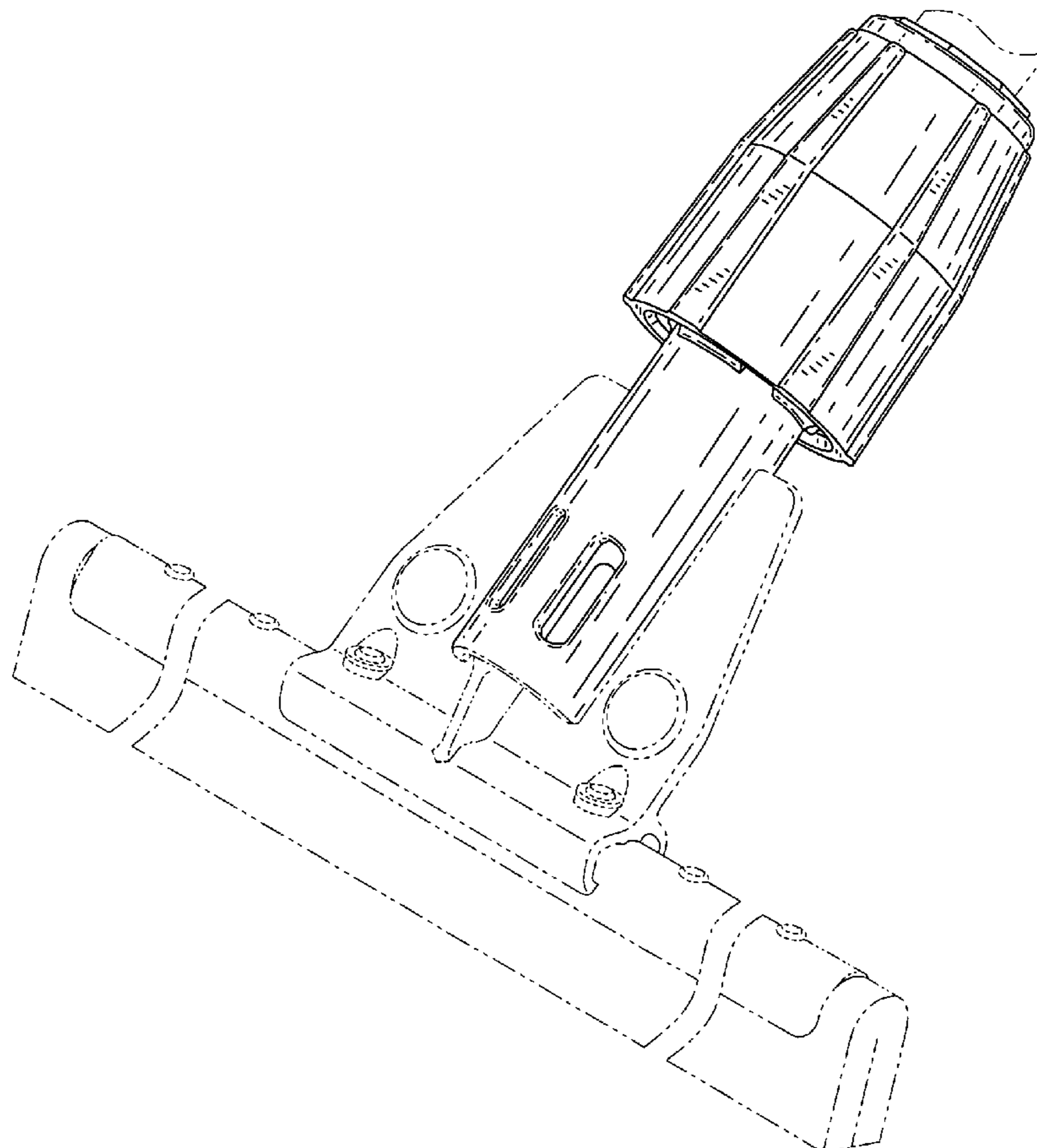

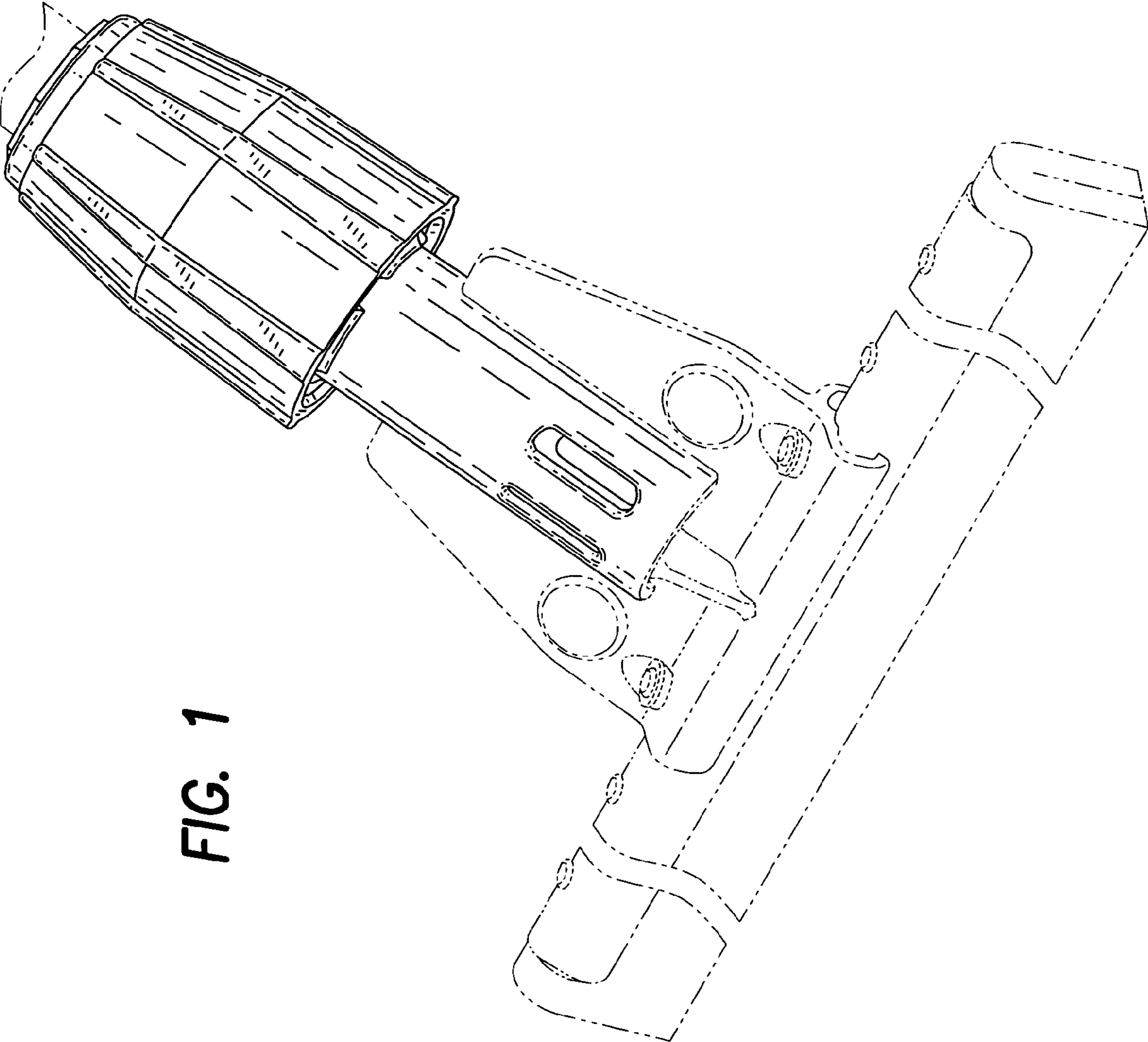

FIG. 1

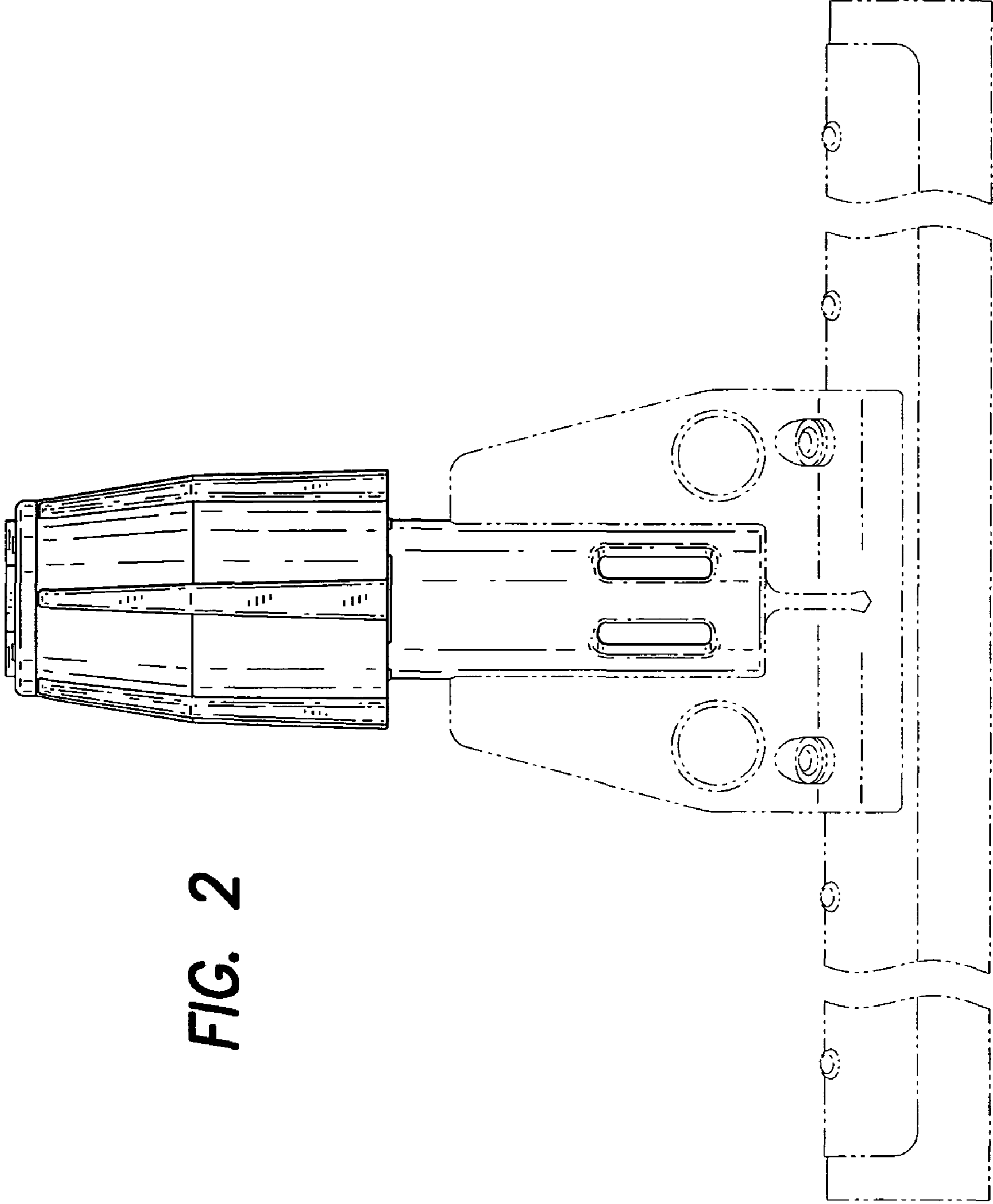

FIG. 2

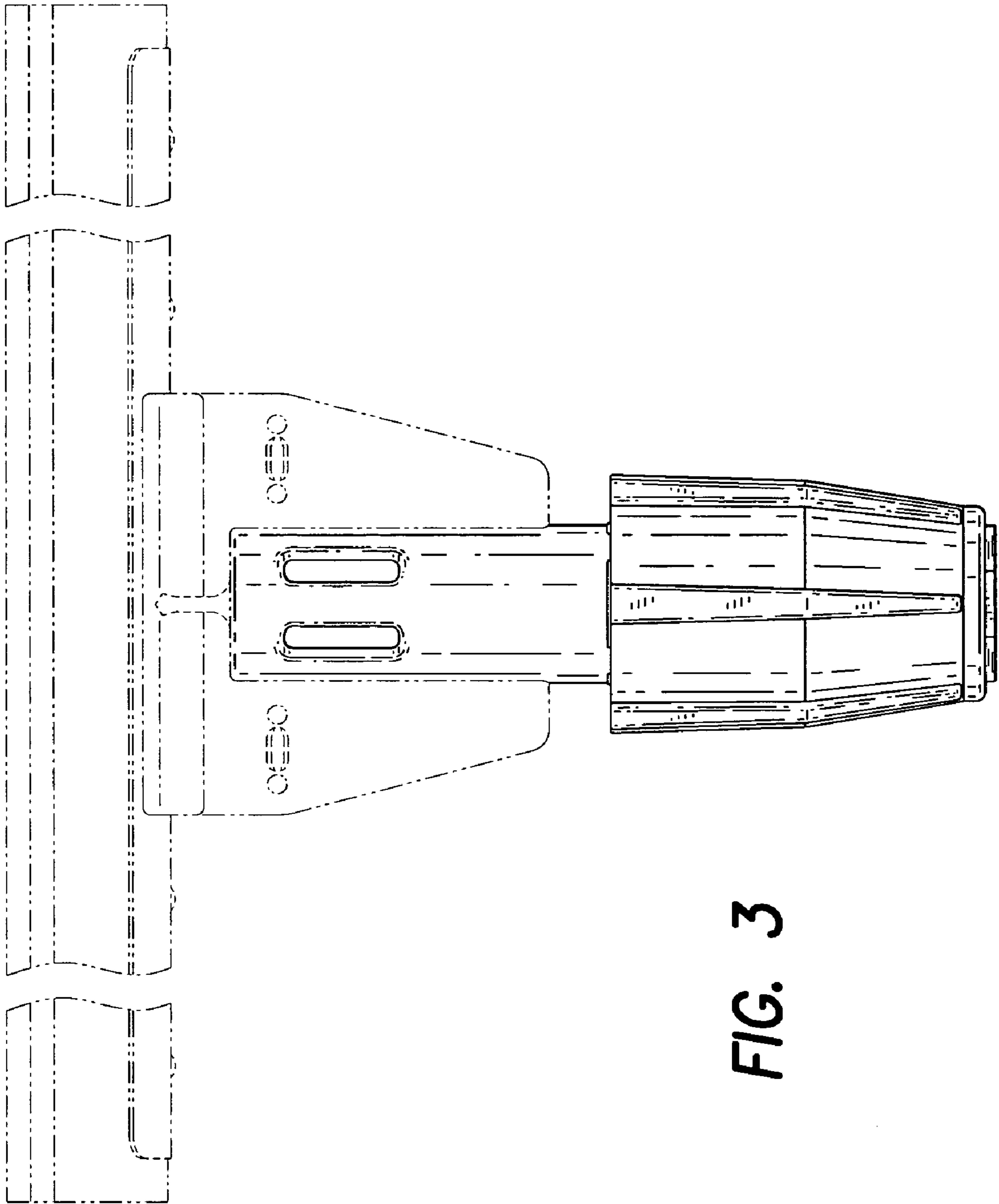
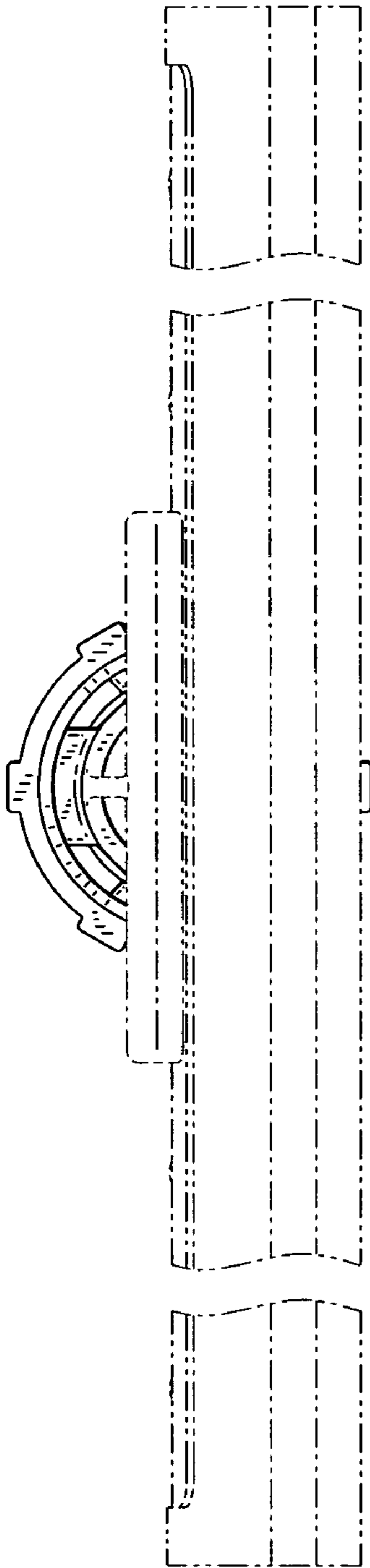
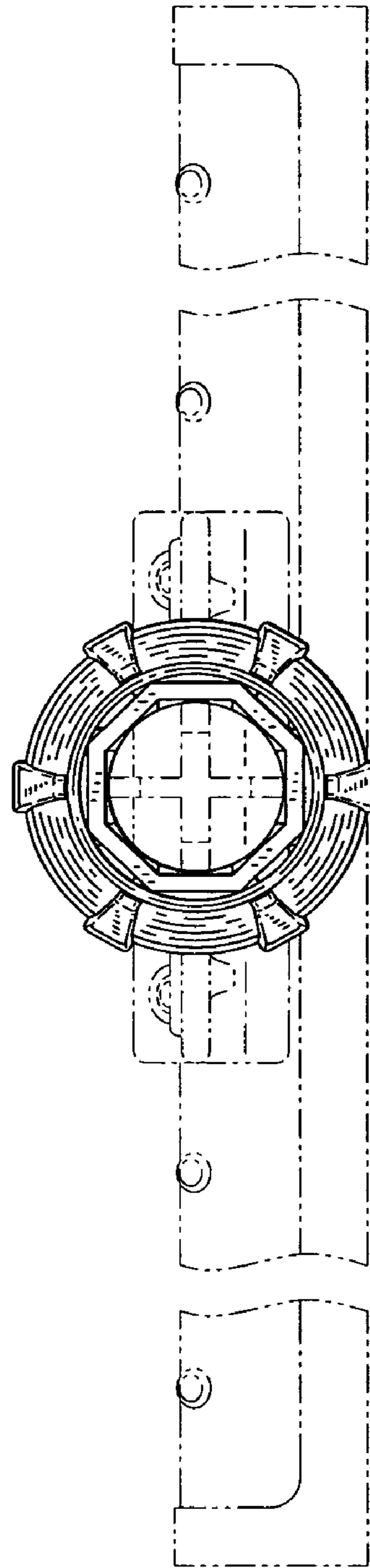

FIG. 3



**FIG. 4**



**FIG. 5**

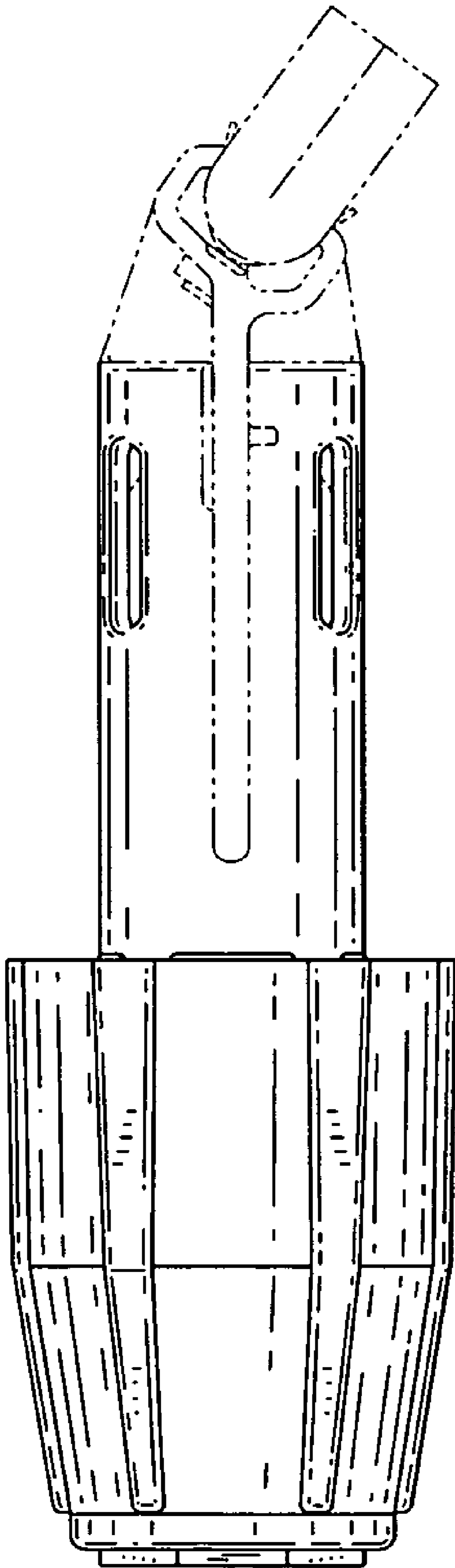

**FIG. 6**