



US00D627031S

(12) **United States Design Patent**  
**Larson**

(10) **Patent No.:** **US D627,031 S**  
(45) **Date of Patent:** **\*\* Nov. 9, 2010**

(54) **AUTOMOTIVE RACING HELMET FISHING REEL**

*Primary Examiner*—Catherine R Oliver  
(74) *Attorney, Agent, or Firm*—John K. McCormick

(76) Inventor: **Michael E. Larson**, 549 Lou's Way,  
Slinger, WI (US) 53089

(57) **CLAIM**

The ornamental design for a automotive racing helmet fishing reel, as shown and described.

(\*\*) Term: **14 Years**

(21) Appl. No.: **29/357,346**

**DESCRIPTION**

(22) Filed: **Mar. 11, 2010**

FIG. 1 is a perspective view of a fishing reel showing my new design.

(51) **LOC (9) Cl.** ..... **22-05**

FIG. 2 is a left side elevation view of the fishing reel of my new design.

(52) **U.S. Cl.** ..... **D22/137**

(58) **Field of Classification Search** ..... D22/137-141;  
242/322, 381, 118.3, 118.4, 118.6, 118.7,  
242/311, 295; 43/20-21

FIG. 3 is a right side elevation view of the fishing reel of my new design.

See application file for complete search history.

FIG. 4 is a front elevation view of the fishing reel of my new design.

(56) **References Cited**

FIG. 5 is a rear elevation view of the fishing reel of my new design.

**U.S. PATENT DOCUMENTS**

FIG. 6 is a plan elevation view of the fishing reel of my new design; and,

D267,580 S *	1/1983	Price	.....	D22/138
D456,874 S *	5/2002	Park	.....	D22/137
D523,921 S *	6/2006	Metheny et al.	.....	D22/139

FIG. 7 is a plan elevation view of the fishing reel of my new design.

\* cited by examiner

**1 Claim, 7 Drawing Sheets**

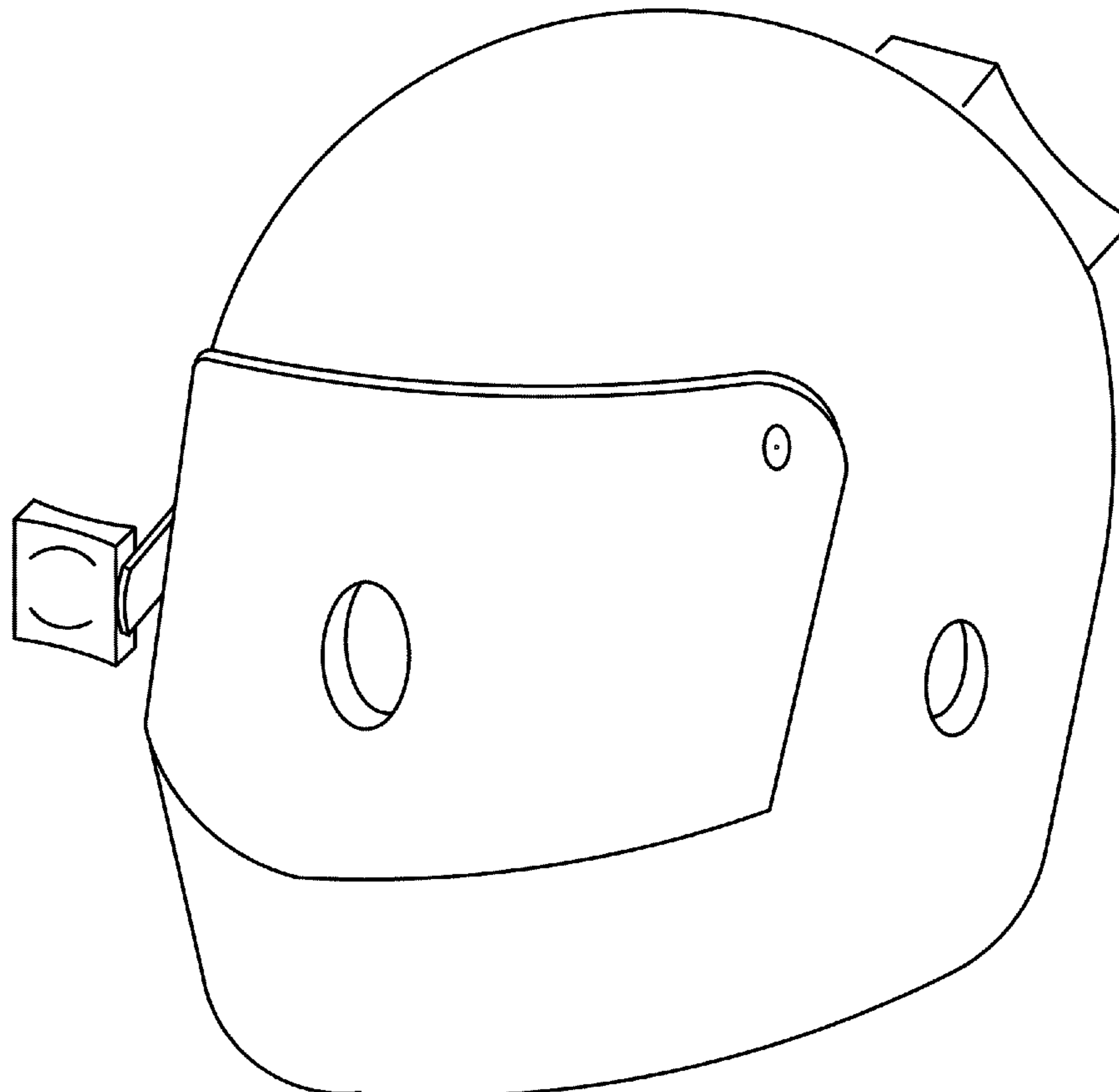

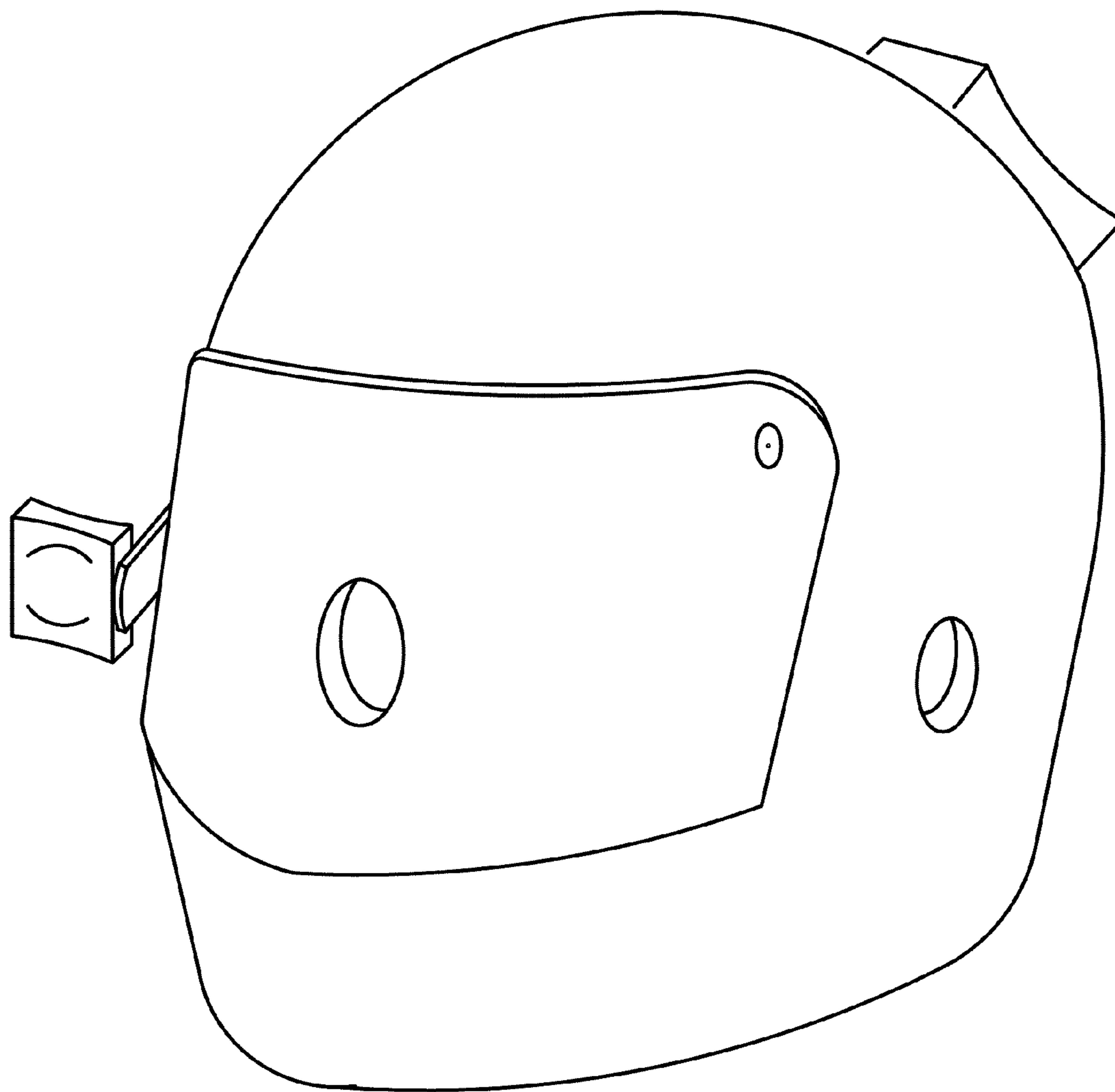

Fig. 1

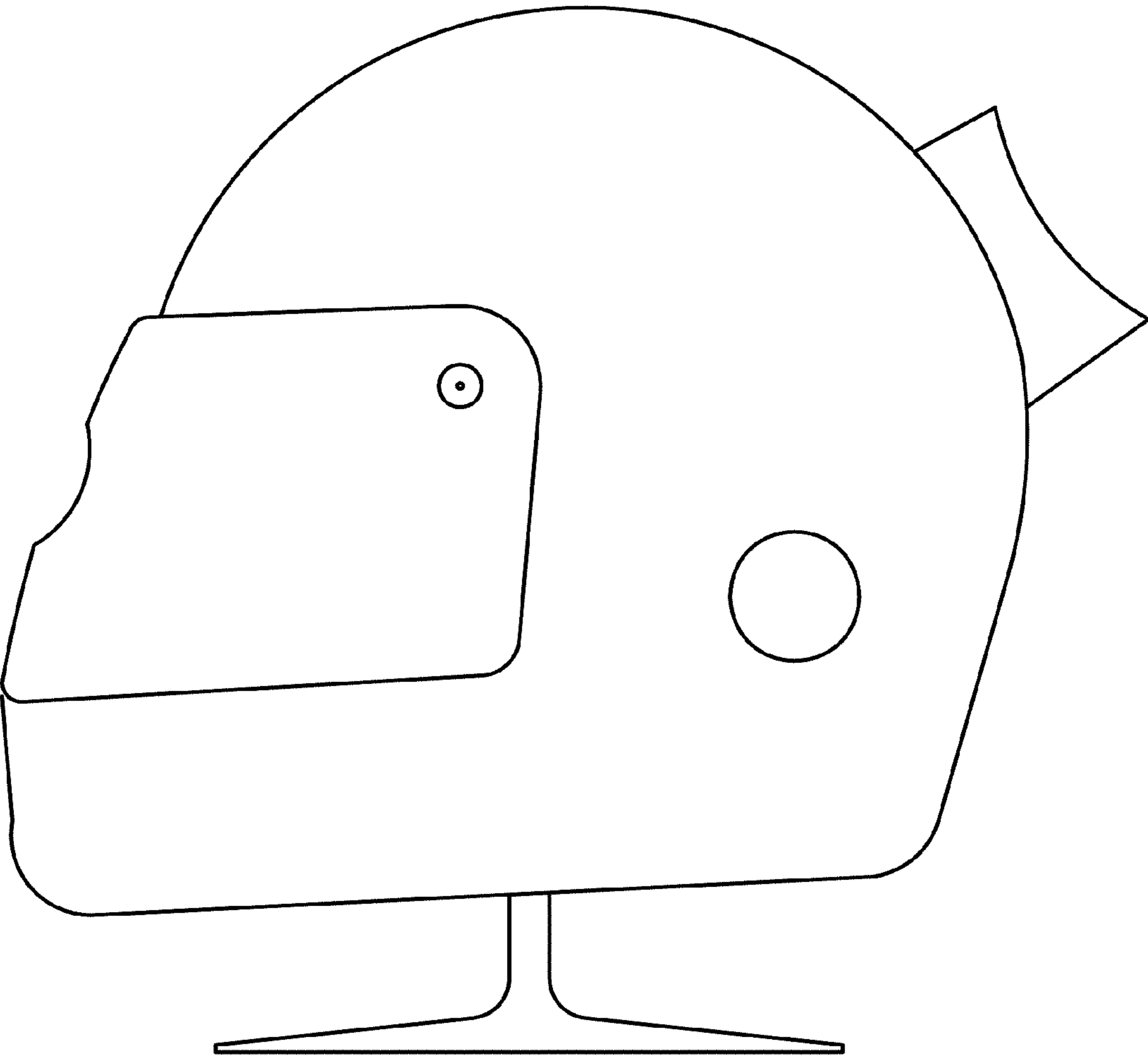

Fig.2

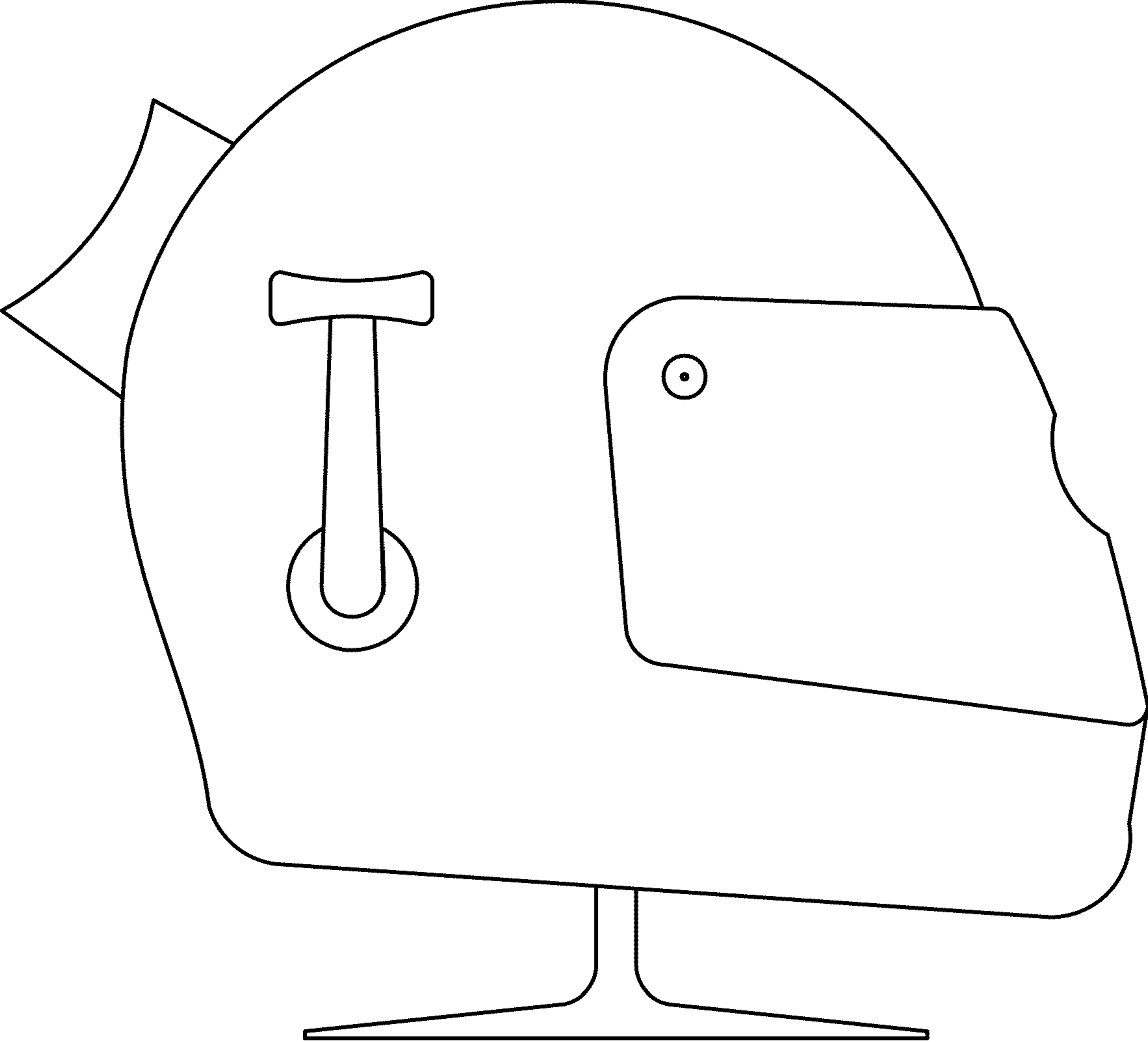

Fig.3

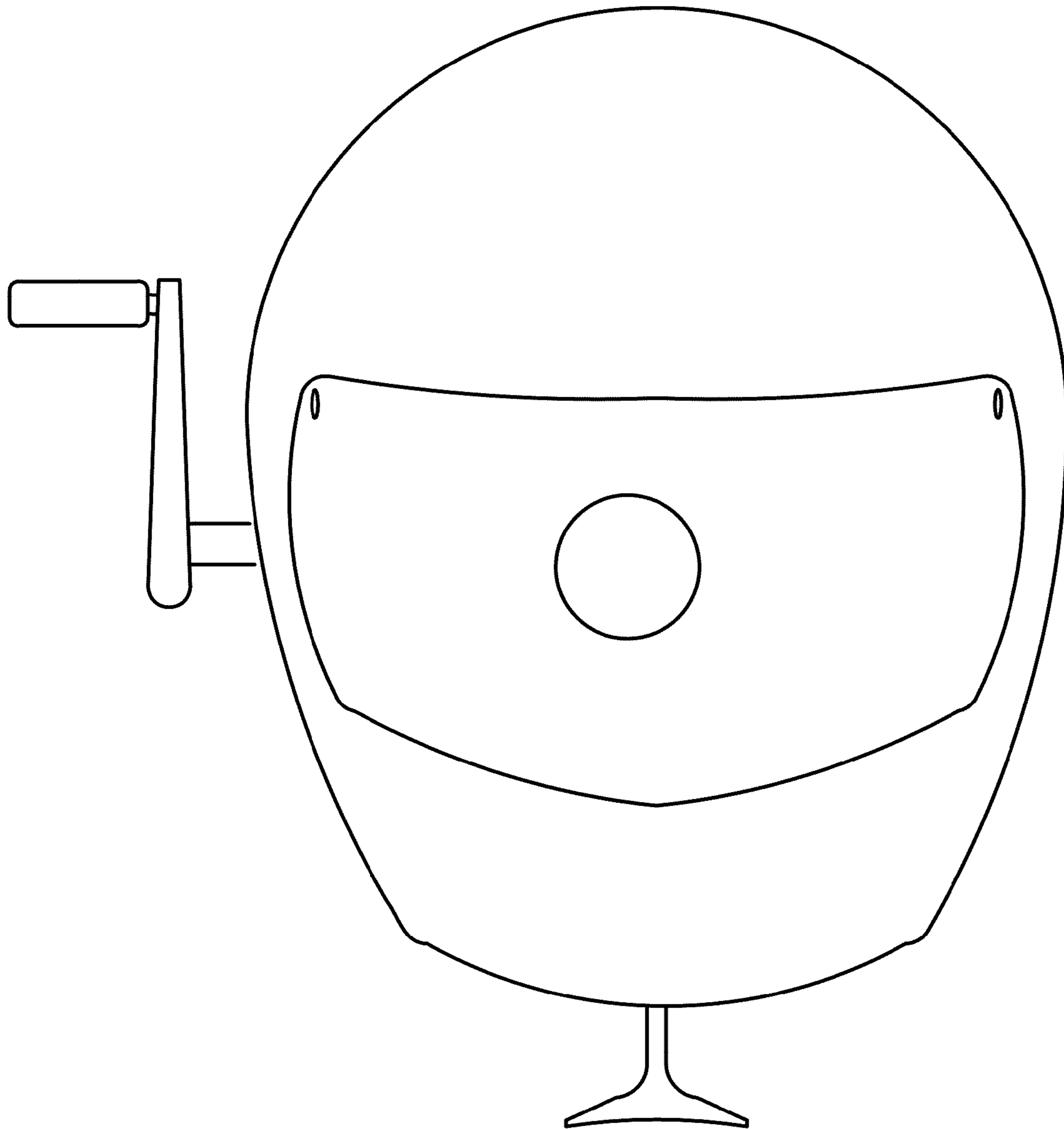

Fig.4

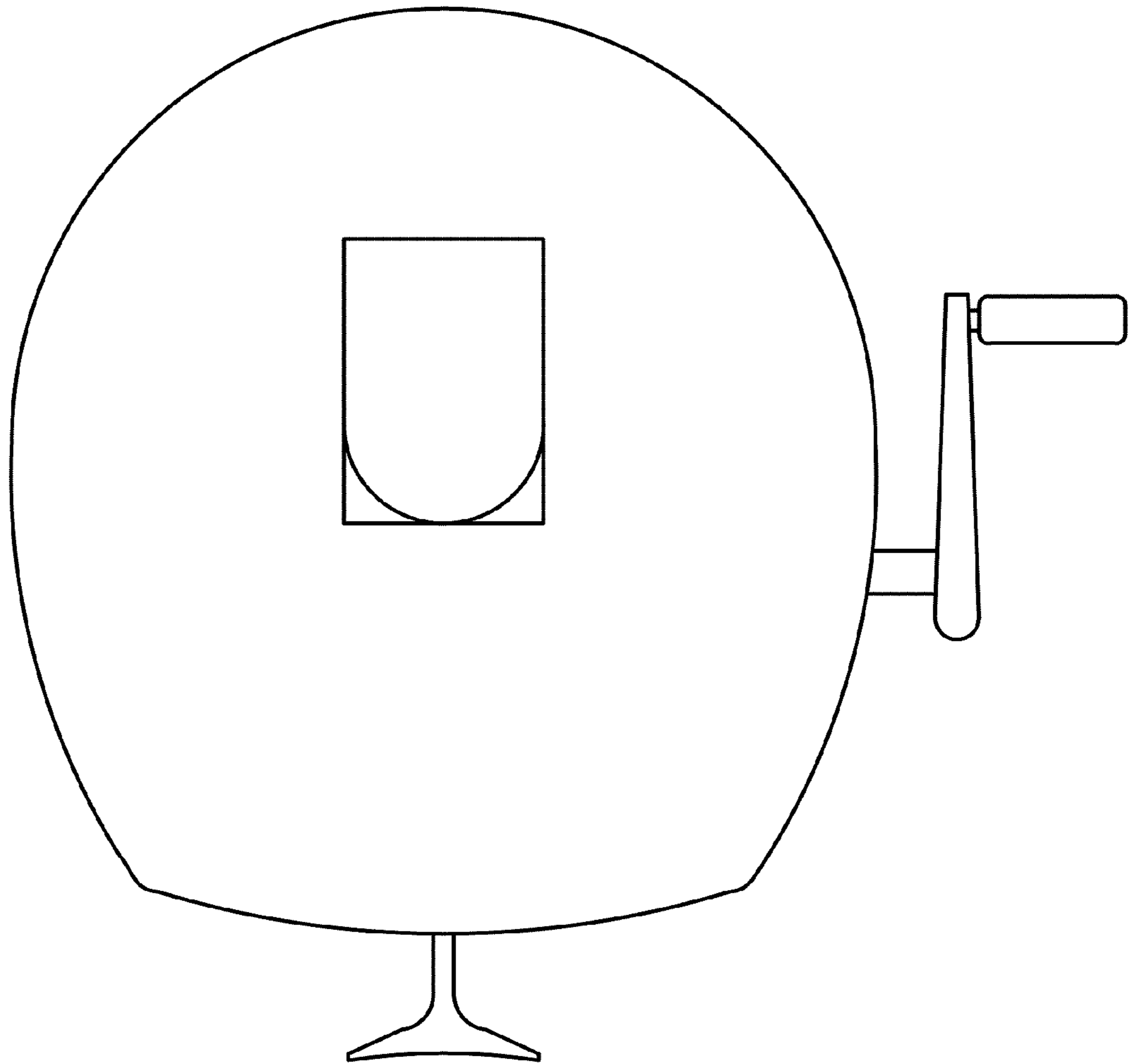

Fig.5

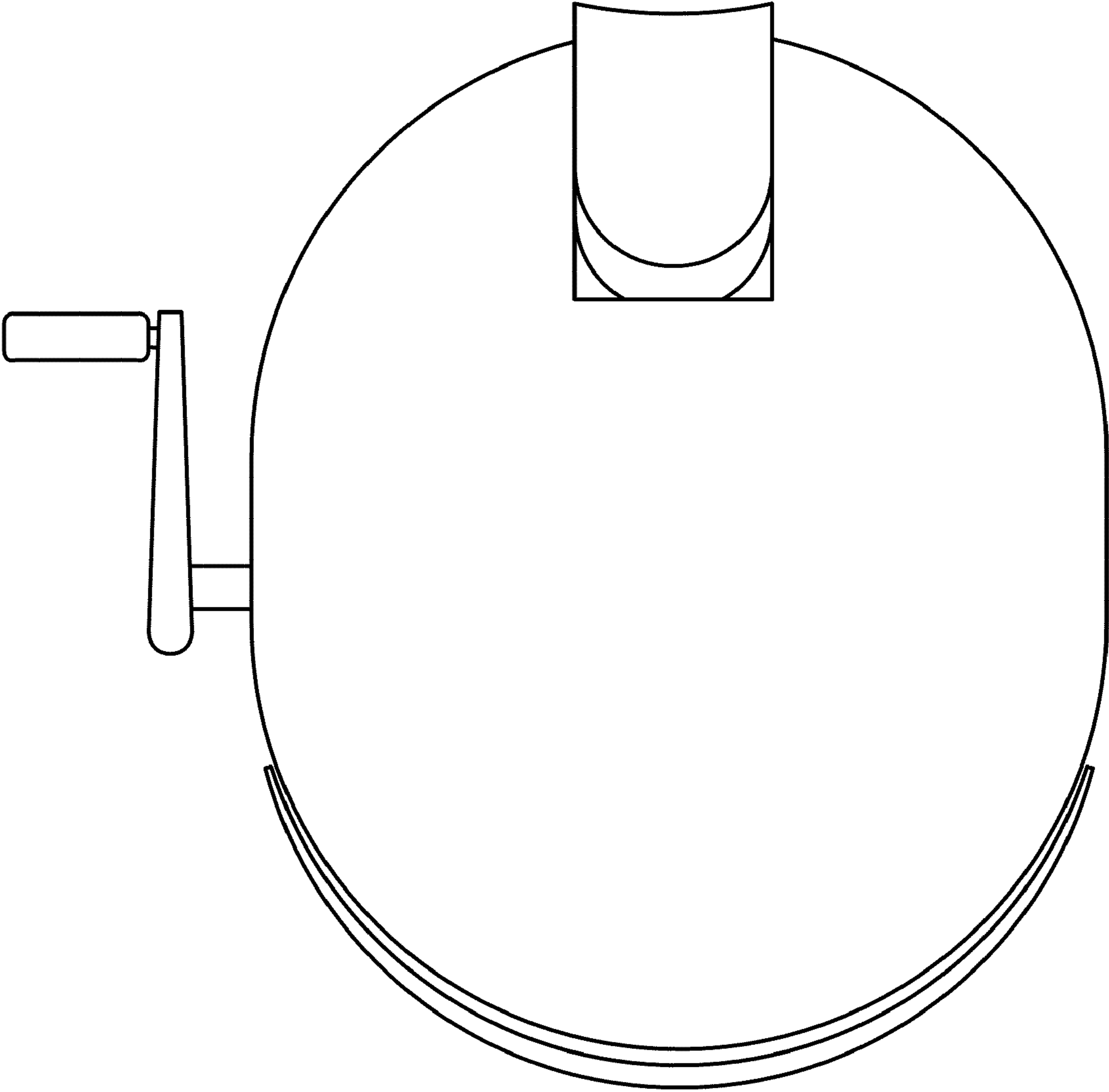

Fig.6

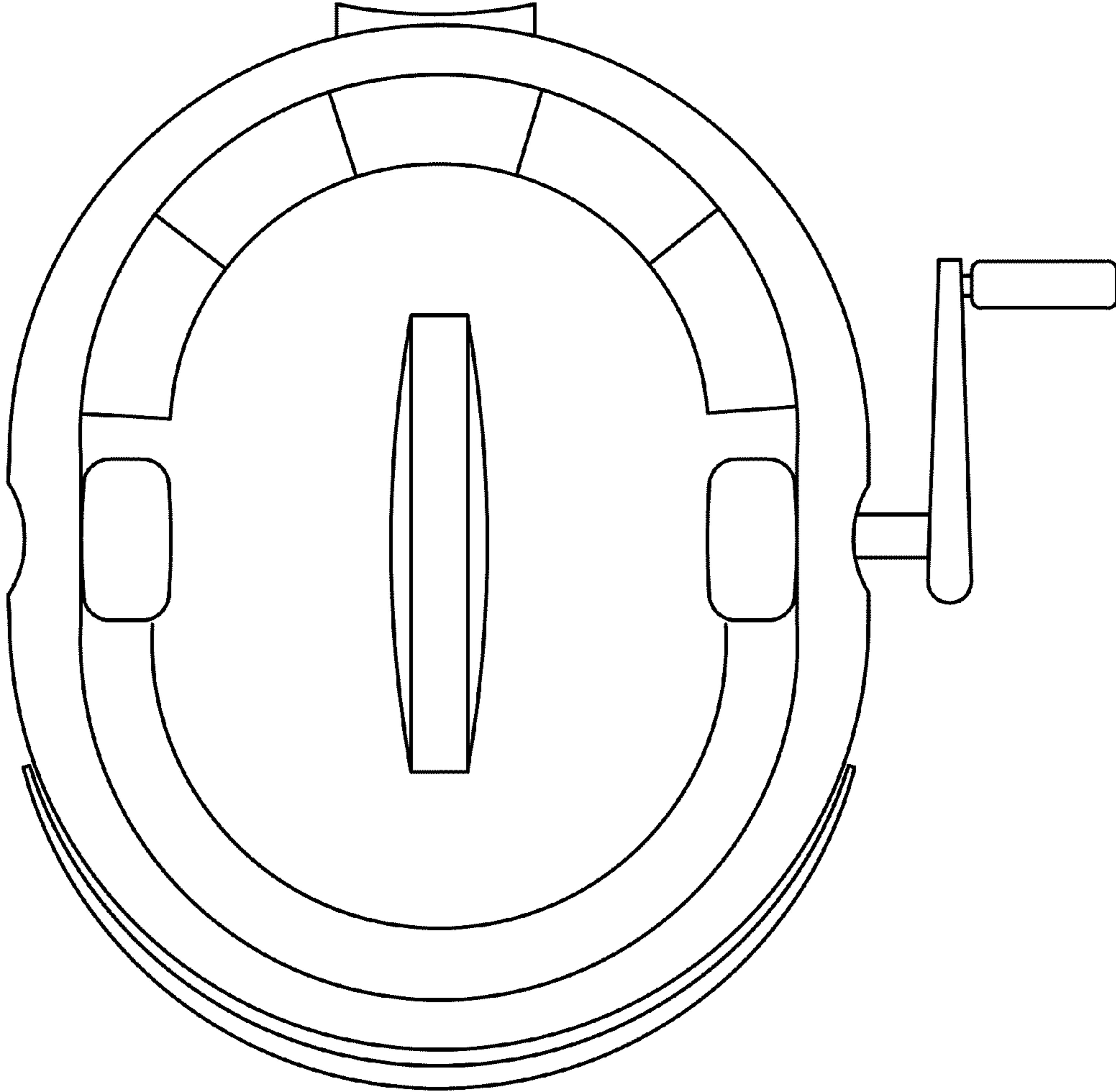

Fig.7