



US00D626906S

(12) **United States Design Patent**
Cazals

(10) **Patent No.:** **US D626,906 S**

(45) **Date of Patent:** **** *Nov. 9, 2010**

(54) **ELEMENTS OF AN AIRCRAFT TAIL**

(75) Inventor: **Olivier Cazals**, Daux (FR)

(73) Assignee: **Airbus Operations S.A.S.**, Toulouse Cedex (FR)

(*) Notice: This patent is subject to a terminal disclaimer.

(**) Term: **14 Years**

(21) Appl. No.: **29/323,643**

(22) Filed: **Aug. 28, 2008**

(51) **LOC (9) Cl.** **12-07**

(52) **U.S. Cl.** **D12/345**

(58) **Field of Classification Search** D12/319,
D12/333, 337, 340-345; D21/447, 448;
244/4 R, 7 B, 12.1, 13, 15, 21, 117 R, 119,
244/130

See application file for complete search history.

(56) **References Cited**

U.S. PATENT DOCUMENTS

D308,043 S *	5/1990	Butler	D12/342
D311,720 S *	10/1990	Butler	D12/331
D314,366 S	2/1991	Waland et al.		
D500,981 S	1/2005	Wilding et al.		
D508,013 S	8/2005	Rihn et al.		
D594,214 S *	6/2009	Matis et al.	D2/969
D594,809 S *	6/2009	Cazals	D12/345
D594,811 S *	6/2009	Cazals	D12/345
D595,207 S *	6/2009	Cazals	D12/345
D595,213 S	6/2009	Cazals		
D595,214 S *	6/2009	Cazals	D12/345
D597,472 S *	8/2009	Cazals	D12/319

OTHER PUBLICATIONS

U.S. Appl. No. 29/323,649, filed Aug. 28, 2008. Title: Aircraft.

“Boeing Flies Blended Wing Body Research Aircraft” Published by Michael on Jul. 26, 2007 in Aviation News and Boeing, Retrieved from: <http://blog.flightstory.net/242/boeing-flies-blended-wing-body-research-aircraft>.

* cited by examiner

Primary Examiner—Cathron C. Brooks

Assistant Examiner—Maurice Stevens

(74) *Attorney, Agent, or Firm*—Osler, Hoskin & Harcourt LLP

(57) **CLAIM**

The ornamental design for elements of an aircraft tail, as shown and described.

DESCRIPTION

FIG. 1 is a front, left perspective view showing elements of an aircraft tail according to an embodiment of my design;

FIG. 2 is a top plan view of the elements of an aircraft tail of FIG. 1;

FIG. 3 is a rear elevation view of the elements of an aircraft tail of FIG. 1;

FIG. 4 is a bottom plan view of the elements of an aircraft tail of FIG. 1, taken along line 4—4 in FIG. 3;

FIG. 5 is a front elevation view of the elements of an aircraft tail of FIG. 1;

FIG. 6 is a left side elevation view of the elements of an aircraft tail of FIG. 1; and,

FIG. 7 is a right side elevation view of the elements of an aircraft tail of FIG. 1.

Throughout the Figures, broken lines showing environment or structure are for illustrative purposes only and form no part of the claimed design.

1 Claim, 6 Drawing Sheets

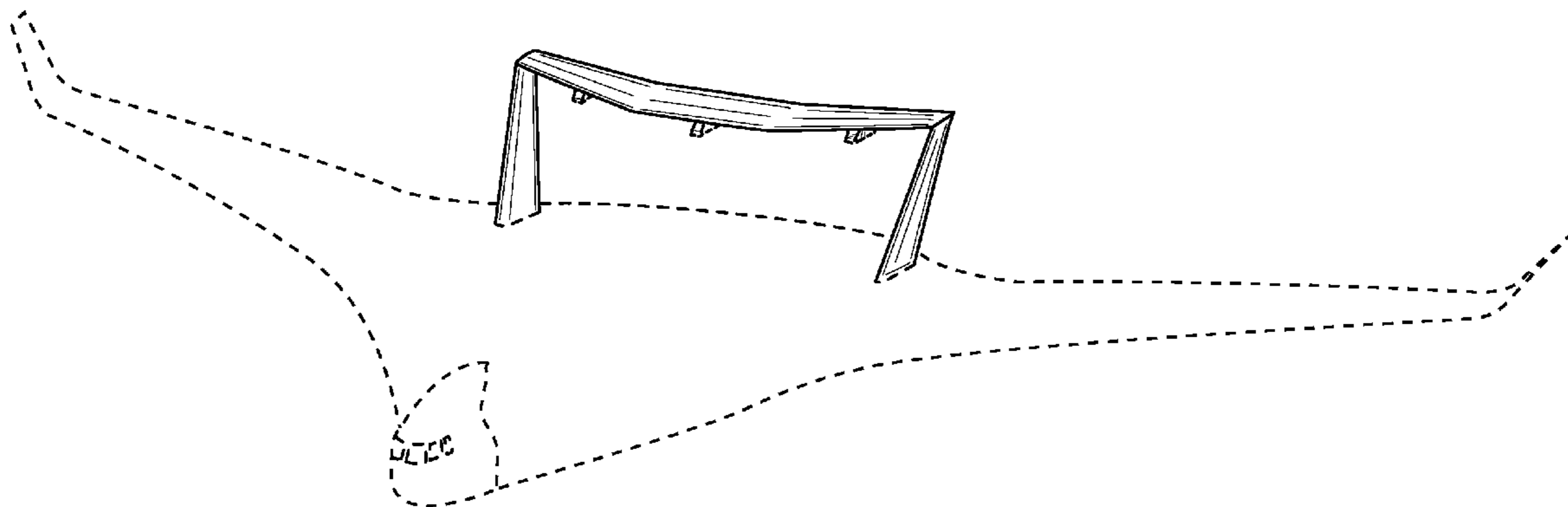

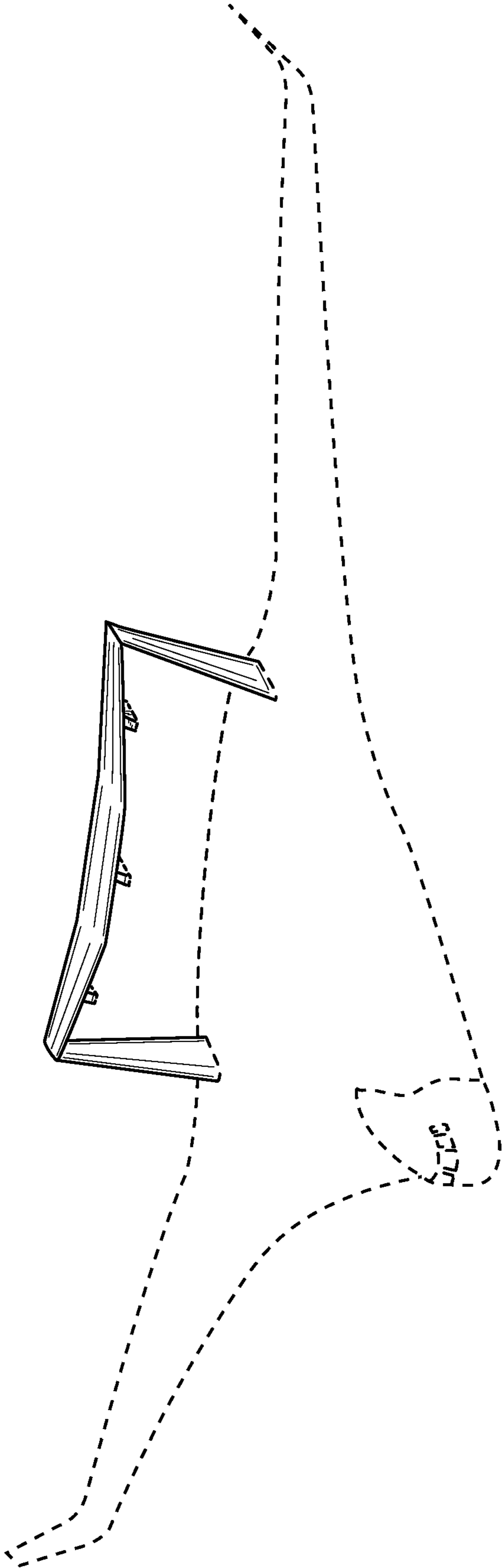

FIG. 1

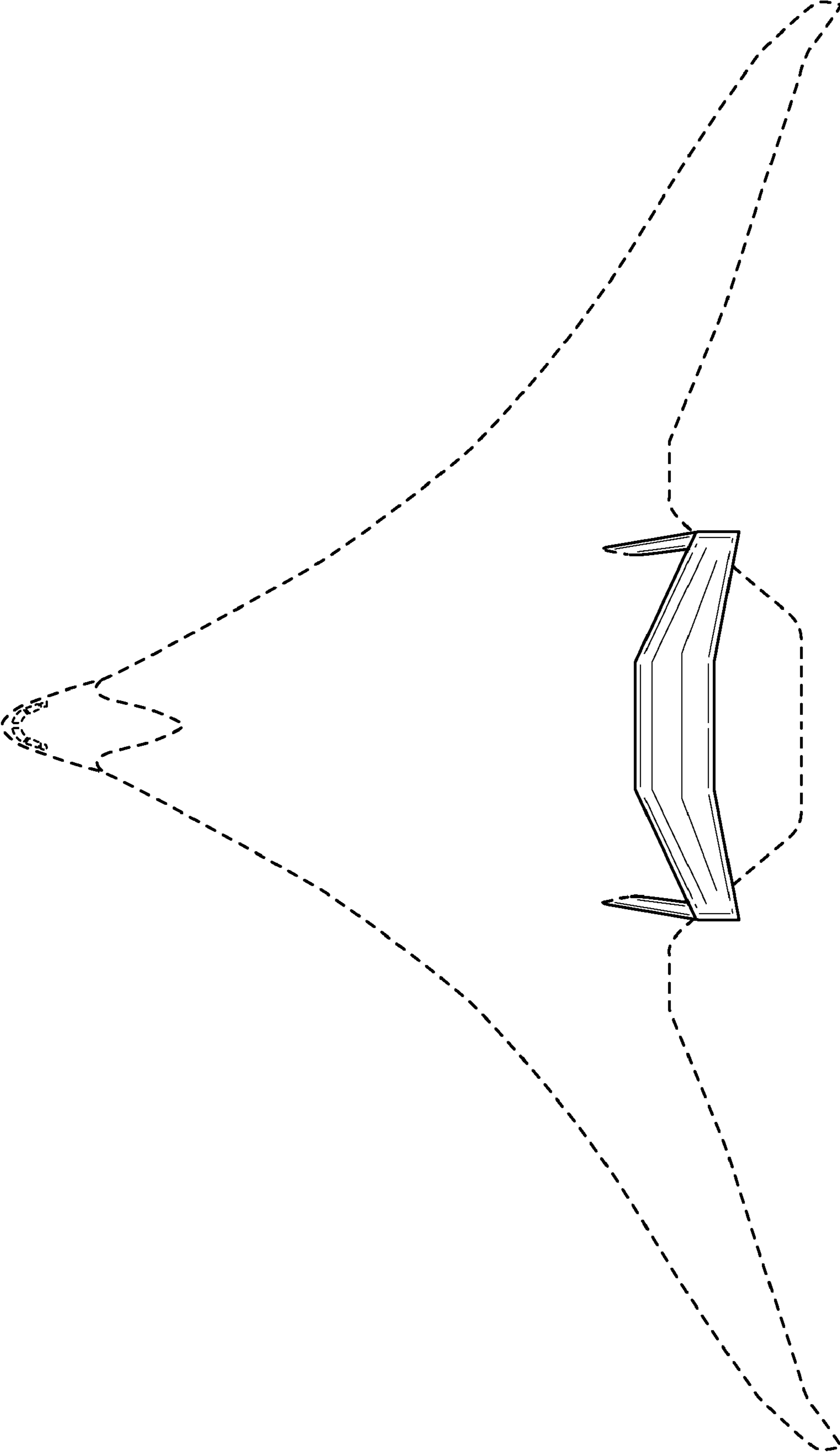

FIG. 2

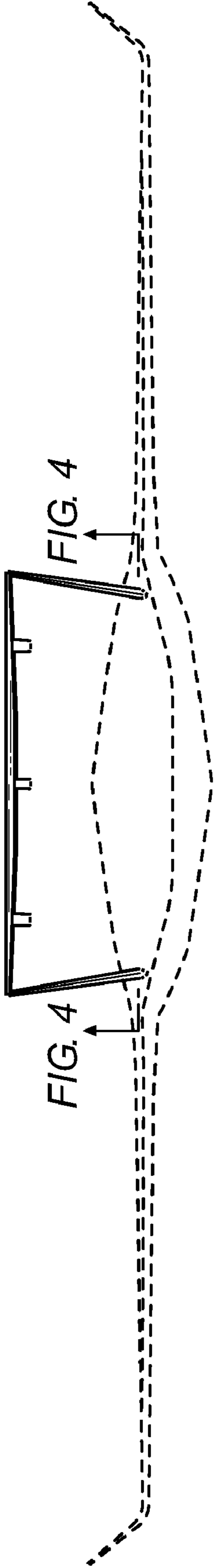

FIG. 3

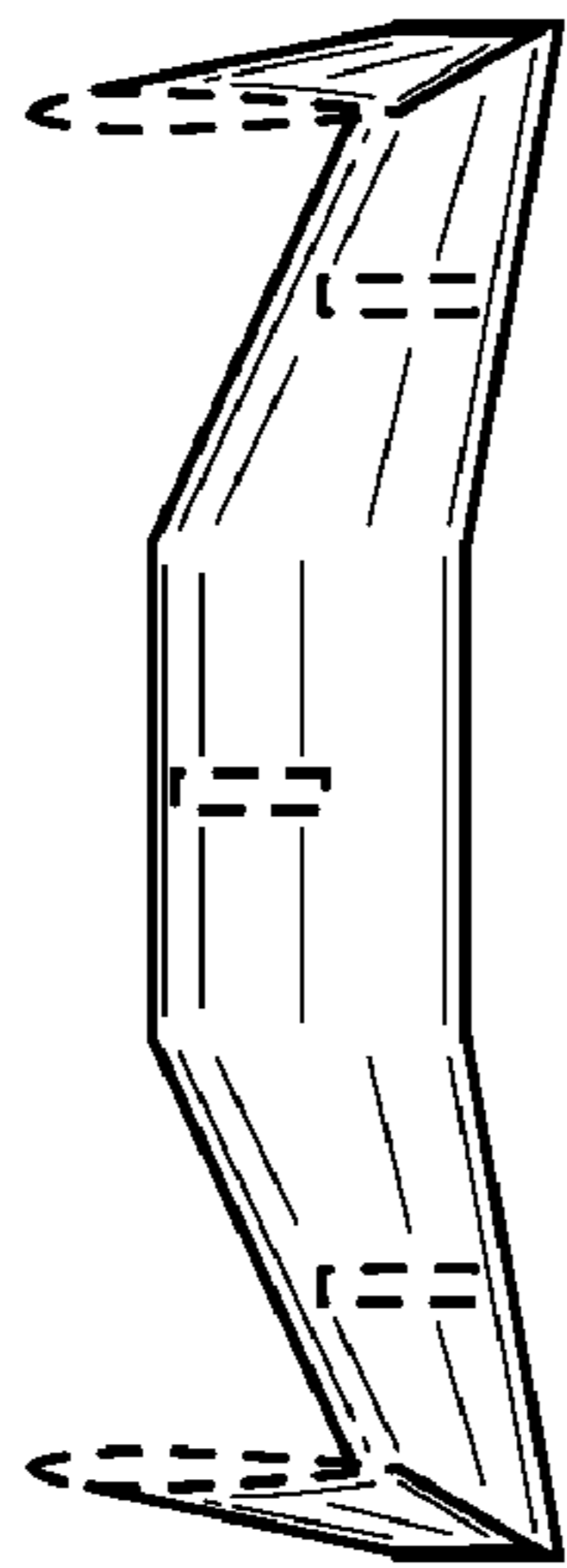

FIG. 4

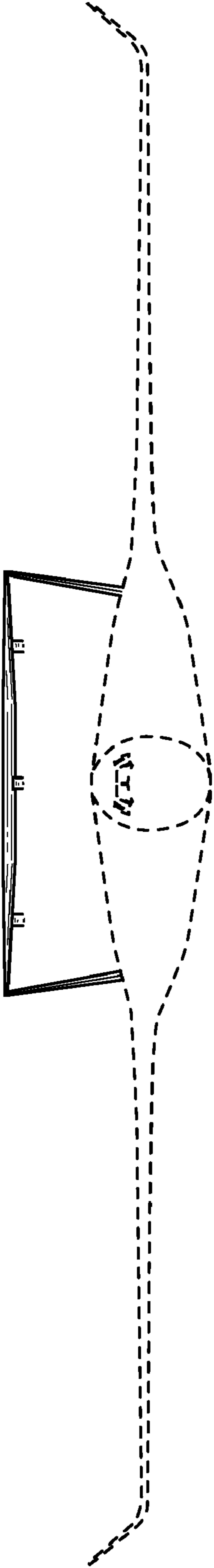

FIG. 5

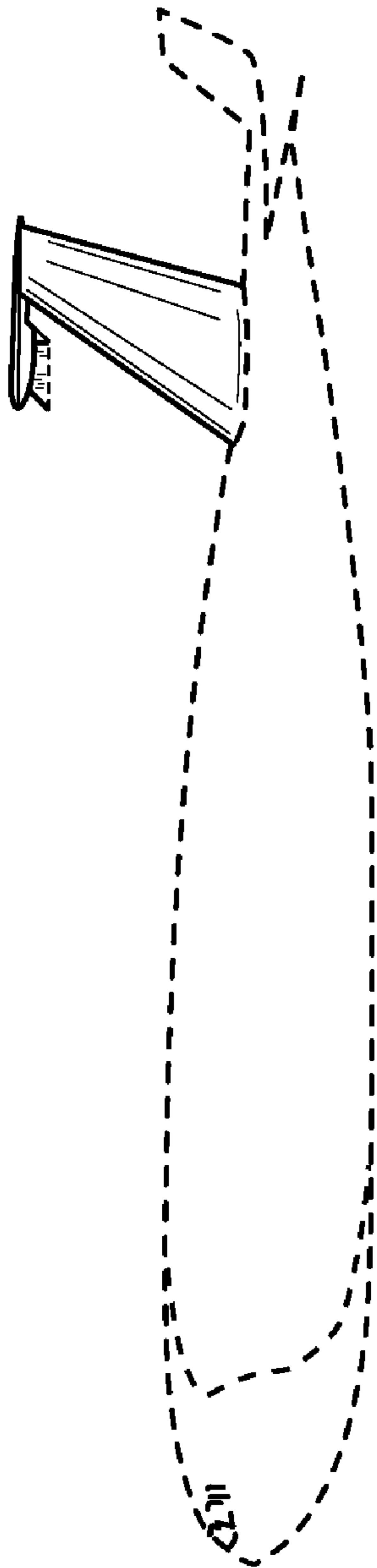

FIG. 6

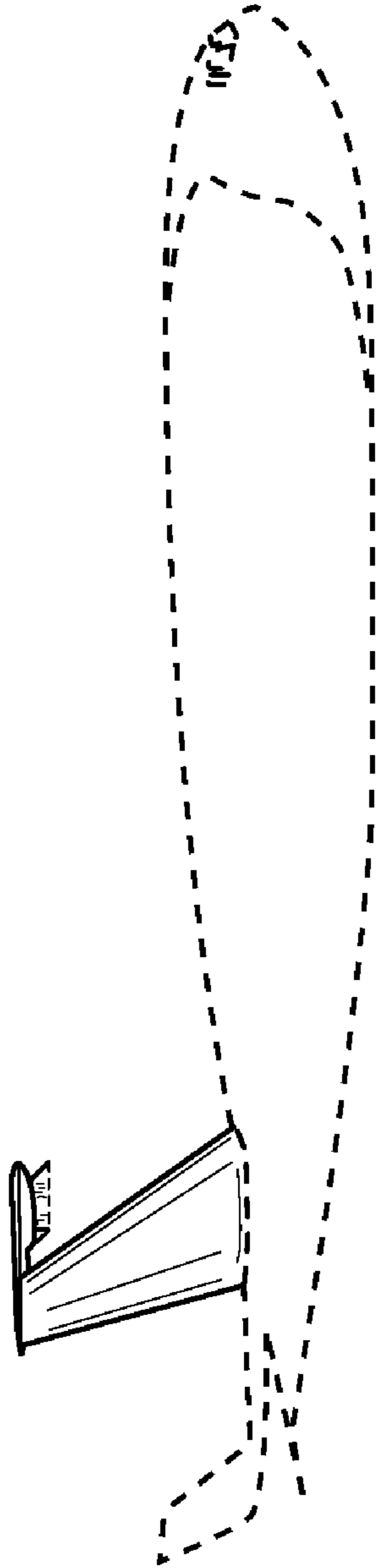

FIG. 7