



US00D626489S

(12) **United States Design Patent**
Laengerer

(10) **Patent No.:** **US D626,489 S**

(45) **Date of Patent:** **** Nov. 2, 2010**

(54) **WHEEL OR WHEEL COVER**

(75) Inventor: **Marcus Laengerer**, Renningen (DE)

(73) Assignee: **Daimler AG**, Stuttgart (DE)

(**) Term: **14 Years**

(21) Appl. No.: **29/311,223**

(22) Filed: **Jan. 22, 2009**

(30) **Foreign Application Priority Data**

Jul. 23, 2008 (EM) 0000975578-0001

(51) **LOC (9) Cl.** **12-16**

(52) **U.S. Cl.** **D12/211**

(58) **Field of Classification Search** D12/204-213;
301/37.101, 101, 65

See application file for complete search history.

(56) **References Cited**

U.S. PATENT DOCUMENTS

D593,020 S * 5/2009 Blasi D12/211

D593,022 S * 5/2009 Forster et al. D12/211

D595,202 S * 6/2009 Spoerle D12/211
D596,551 S * 7/2009 Futschik et al. D12/211
D596,552 S * 7/2009 Beermann D12/211
D598,357 S * 8/2009 Chung D12/211

* cited by examiner

Primary Examiner—Caron Veynar

Assistant Examiner—Katrina A Kile

(74) *Attorney, Agent, or Firm*—Crowell & Moring LLP

(57) **CLAIM**

The ornamental design for a wheel or wheel cover, as shown and described.

DESCRIPTION

FIG. 1 is a front view of a wheel or wheel cover according to my novel design; and,

FIG. 2 is a perspective view thereof.

The broken line showing of the rear portion of the wheel rim and the central hub area is included for the purpose of illustrating environment and form no part of the claimed design.

1 Claim, 1 Drawing Sheet

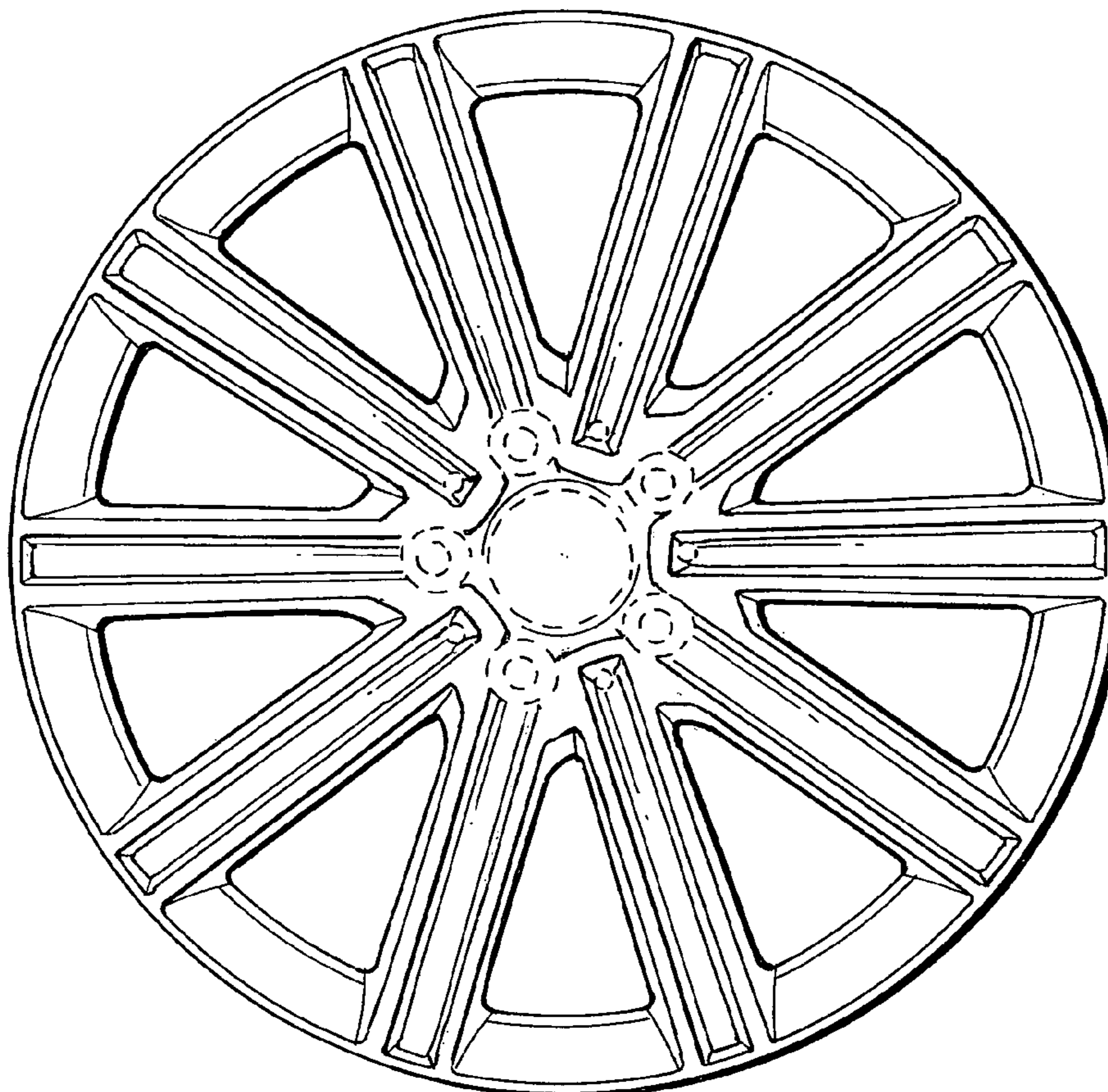

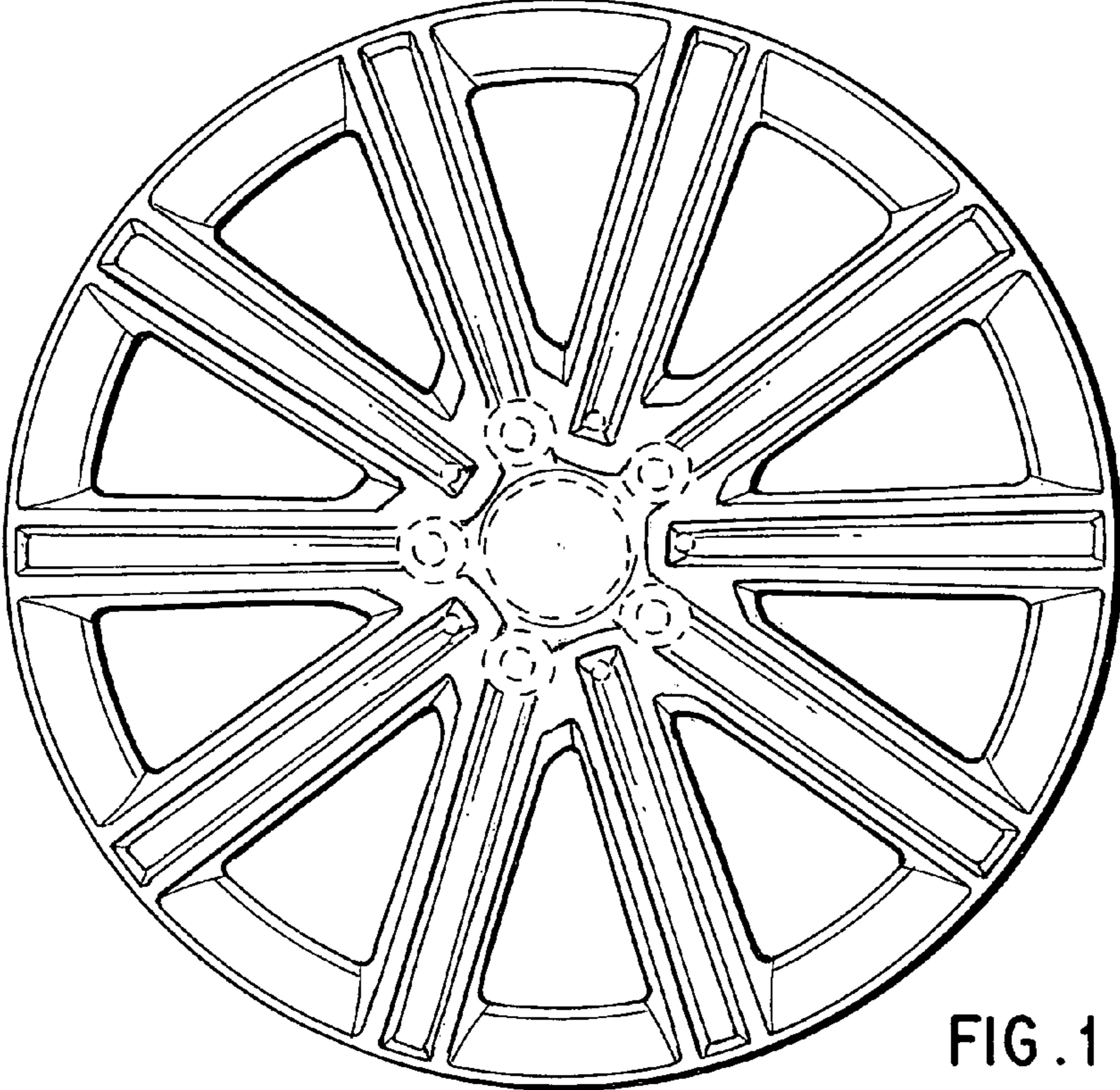

FIG. 1

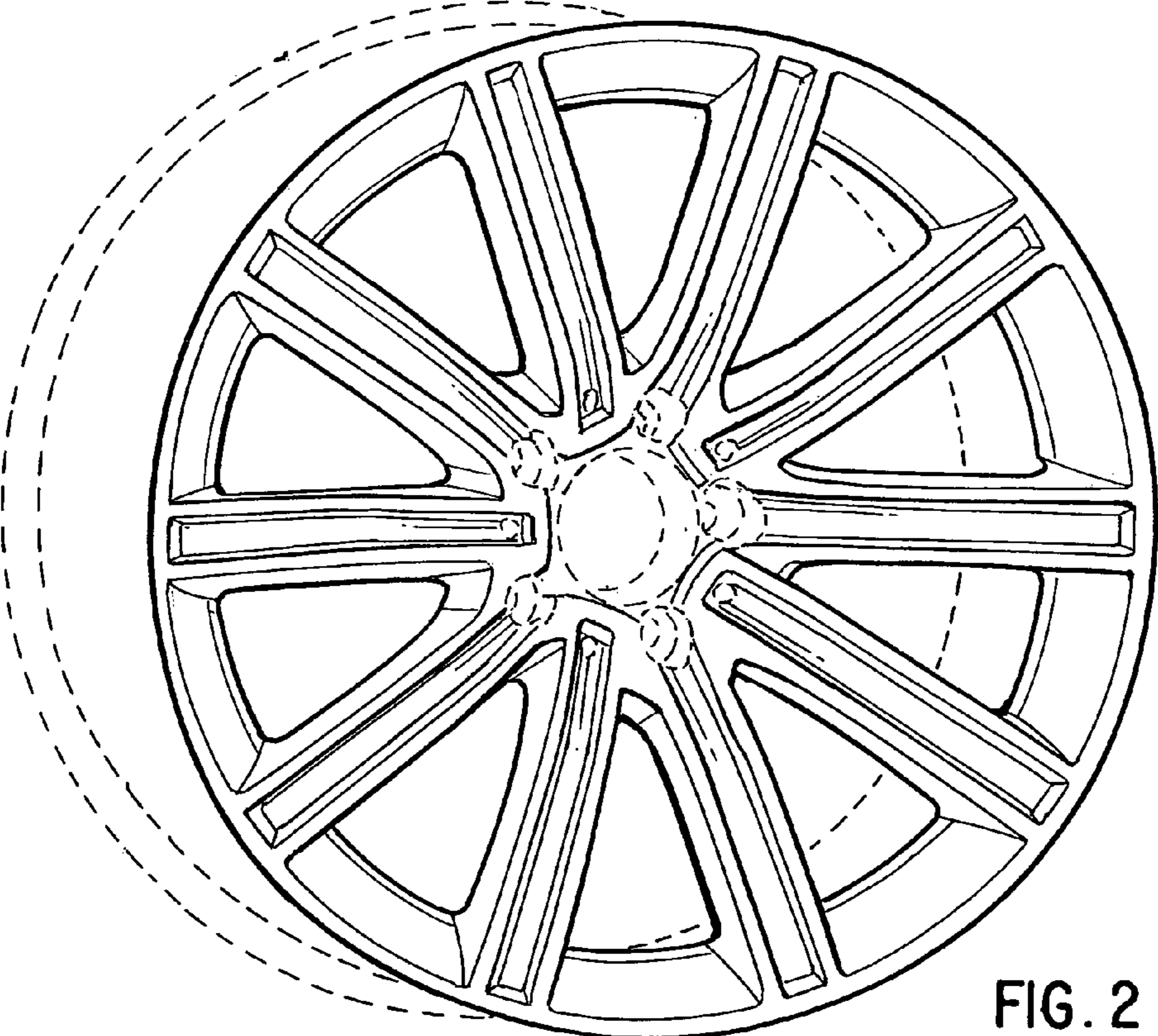

FIG. 2