



US00D626483S

(12) **United States Design Patent**  
**Prichard et al.**

(10) **Patent No.:** **US D626,483 S**  
(45) **Date of Patent:** **\*\* Nov. 2, 2010**

(54) **SENSOR ASSEMBLY FOR A VEHICLE DOOR**

(75) Inventors: **Mark A. Prichard**, Glen Ellyn, IL (US);  
**Steven L. Wiora**, Sycamore, IL (US)

(73) Assignee: **Control Solutions LLC**, Aurora, IL  
(US)

(\*\*) Term: **14 Years**

(21) Appl. No.: **29/345,679**

(22) Filed: **Oct. 20, 2009**

(51) **LOC (9) Cl.** ..... **12-16**

(52) **U.S. Cl.** ..... **D12/195**

(58) **Field of Classification Search** ..... D12/195,  
D12/193, 414, 190, 196; 180/190; 280/750-752;  
296/190.01-191, 70, 193.08, 145, 153, 37.1-37.13,  
296/149, 146.1; D15/17, 28; D10/46, 98,  
D10/102-103; 49/501-302; D8/302-303  
See application file for complete search history.

(56) **References Cited**

**U.S. PATENT DOCUMENTS**

5,050,347	A *	9/1991	Brusasco	49/348
5,050,350	A *	9/1991	Bertolini et al.	49/502
2006/0061133	A1 *	3/2006	Sawajiri	296/146.1
2006/0097536	A1 *	5/2006	DePue et al.	296/37.8
2007/0039245	A1 *	2/2007	Buchta et al.	49/502
2007/0080560	A1 *	4/2007	Sommer et al.	296/153
2008/0034667	A1 *	2/2008	Fischer	49/502
2008/0034668	A1 *	2/2008	Fischer	49/502
2008/0229671	A1 *	9/2008	Takeda et al.	49/502
2008/0265613	A1 *	10/2008	Hockenberry et al.	296/146.1
2008/0284202	A1 *	11/2008	Filipczak et al.	296/146.1
2009/0145041	A1 *	6/2009	Yamada et al.	49/501
2009/0256384	A1 *	10/2009	Hughes et al.	296/153

2010/0072769	A1 *	3/2010	Schilles	296/37.13
2010/0199571	A1 *	8/2010	Bush et al.	49/502
2010/0218345	A1 *	9/2010	Villeminey	16/412

\* cited by examiner

*Primary Examiner*—Caron Veynar

*Assistant Examiner*—Katrina A Kile

(74) *Attorney, Agent, or Firm*—The Eclipse Group LLP

(57) **CLAIM**

We claim the ornamental design for a sensor assembly for a vehicle door, as shown and described.

**DESCRIPTION**

FIG. 1 is a top right perspective view of the sensor assembly for a vehicle door;

FIG. 2 is a top left perspective view thereof;

FIG. 3 is a bottom left perspective view thereof;

FIG. 4 is a bottom right perspective view thereof;

FIG. 5 is a front view thereof;

FIG. 6 is a rear view thereof;

FIG. 7 is a left side view thereof;

FIG. 8 is a right side view thereof;

FIG. 9 is a top view thereof;

FIG. 10 is a bottom view thereof; and,

FIG. 11 is a top left perspective view of an alternative embodiment of the sensor assembly for a vehicle door.

The second embodiment is a mirror image of sensor assembly for a vehicle door as shown in FIGS. 1-10.

In the drawings, the broken lines depict portions of the design that form no part of the claim.

**1 Claim, 9 Drawing Sheets**

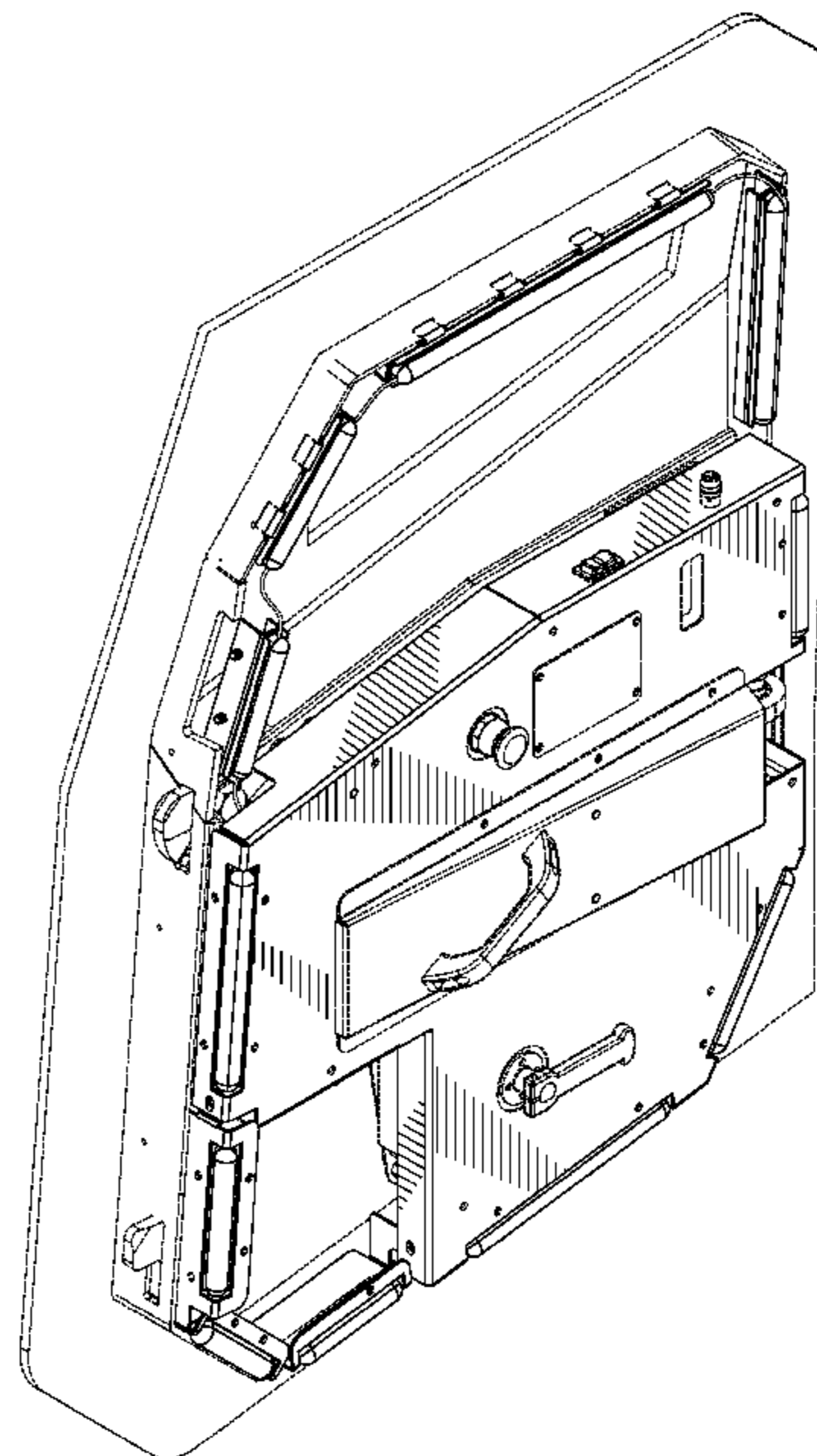
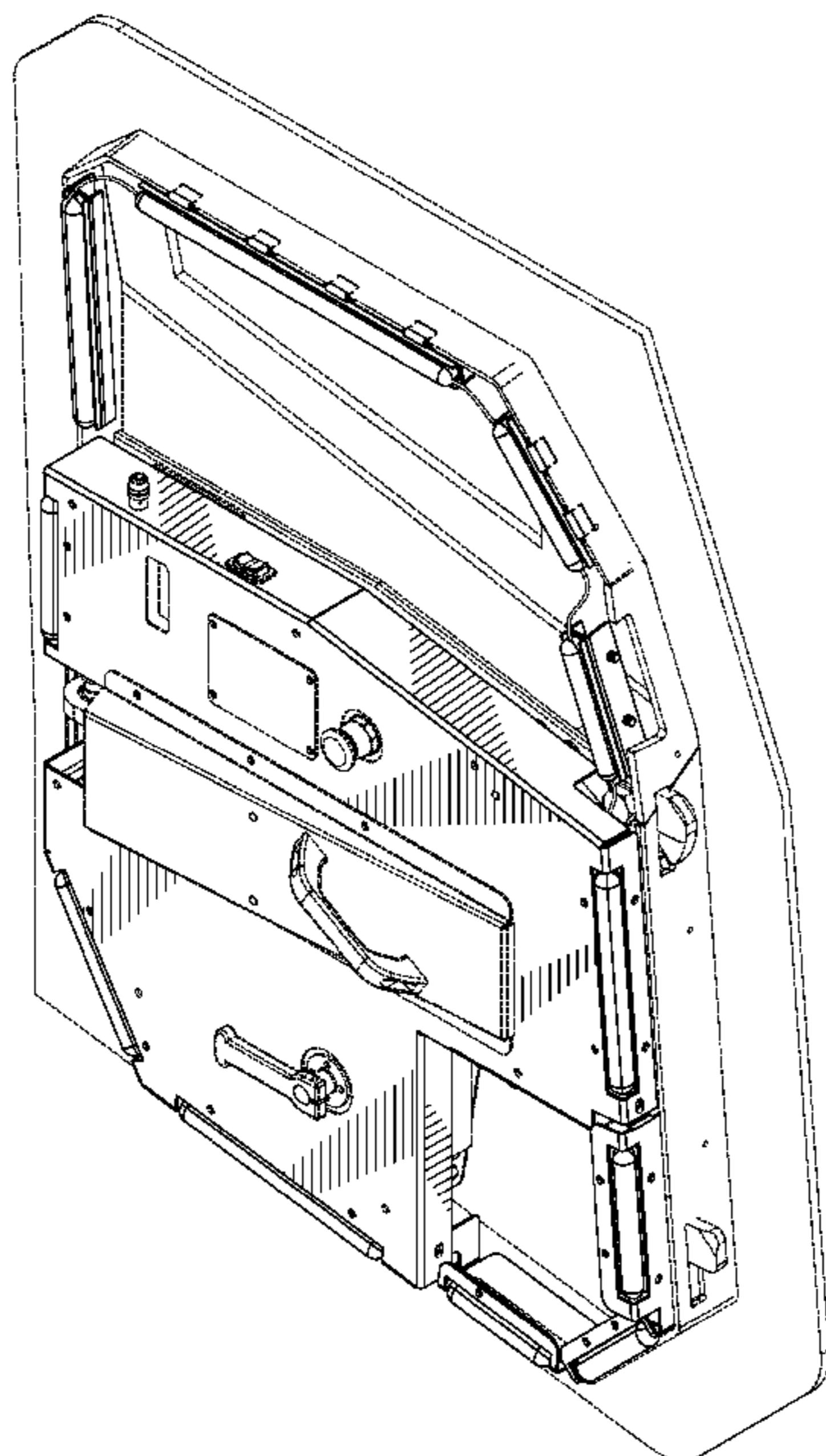

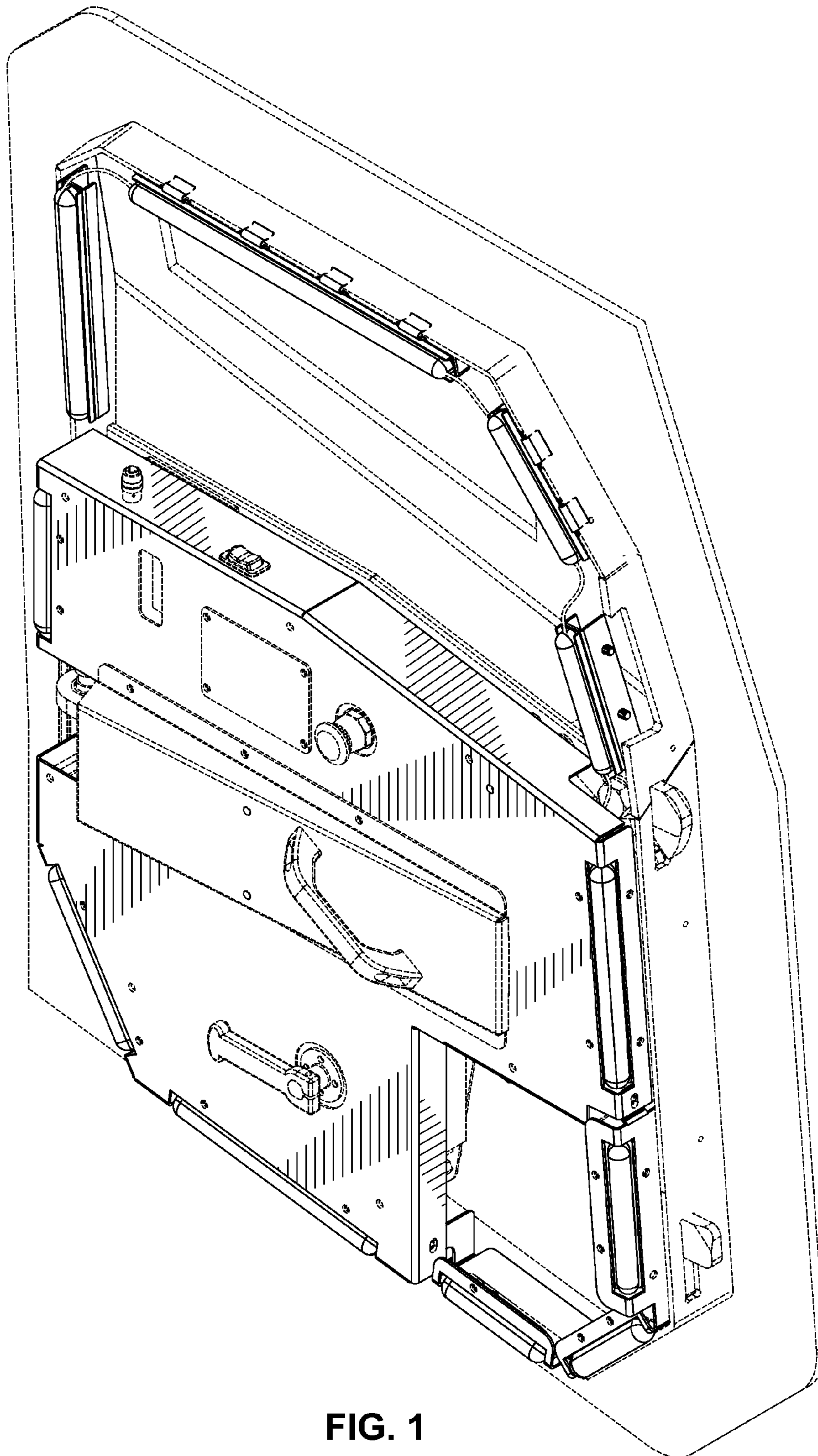

FIG. 1

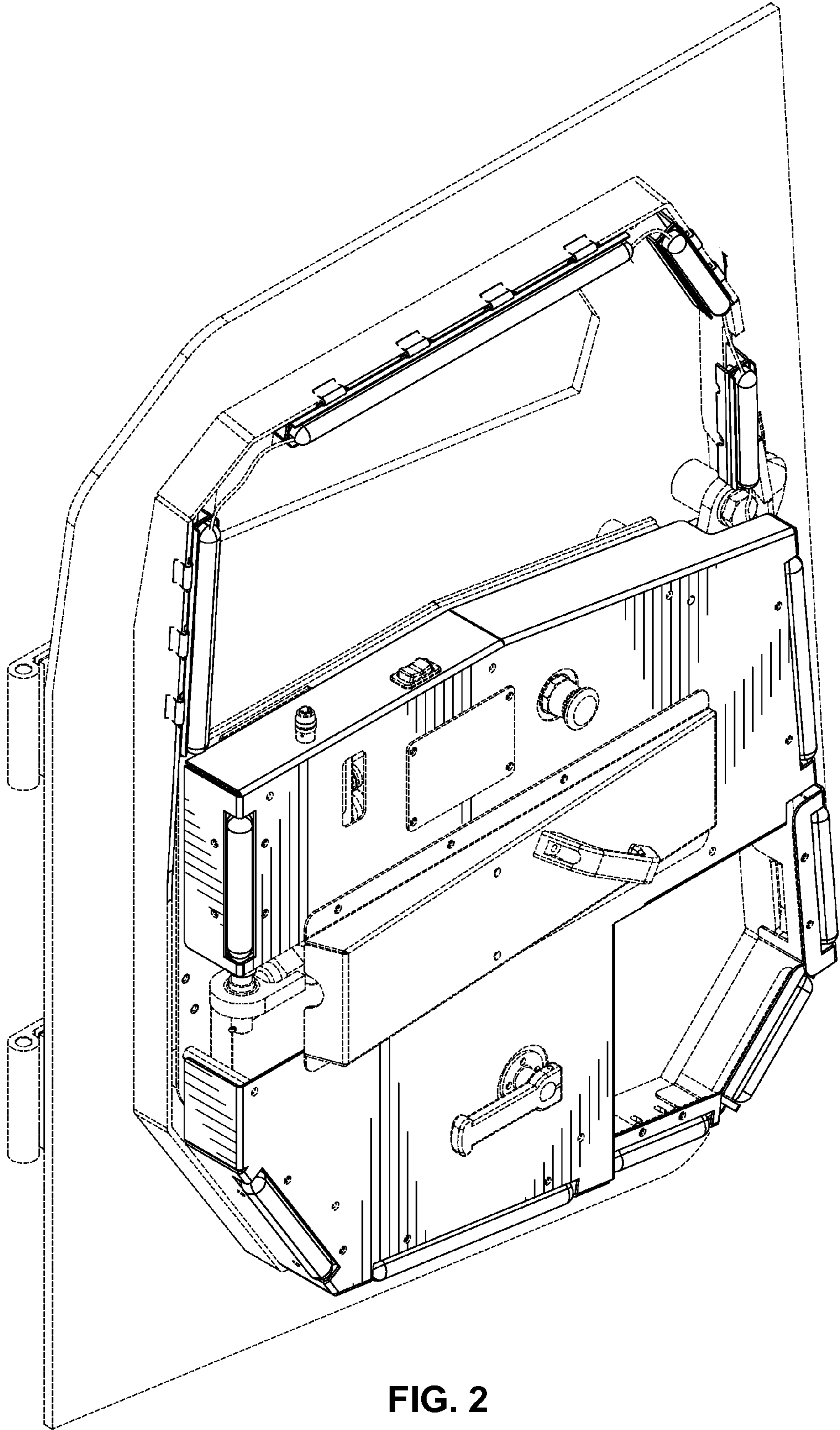

FIG. 2

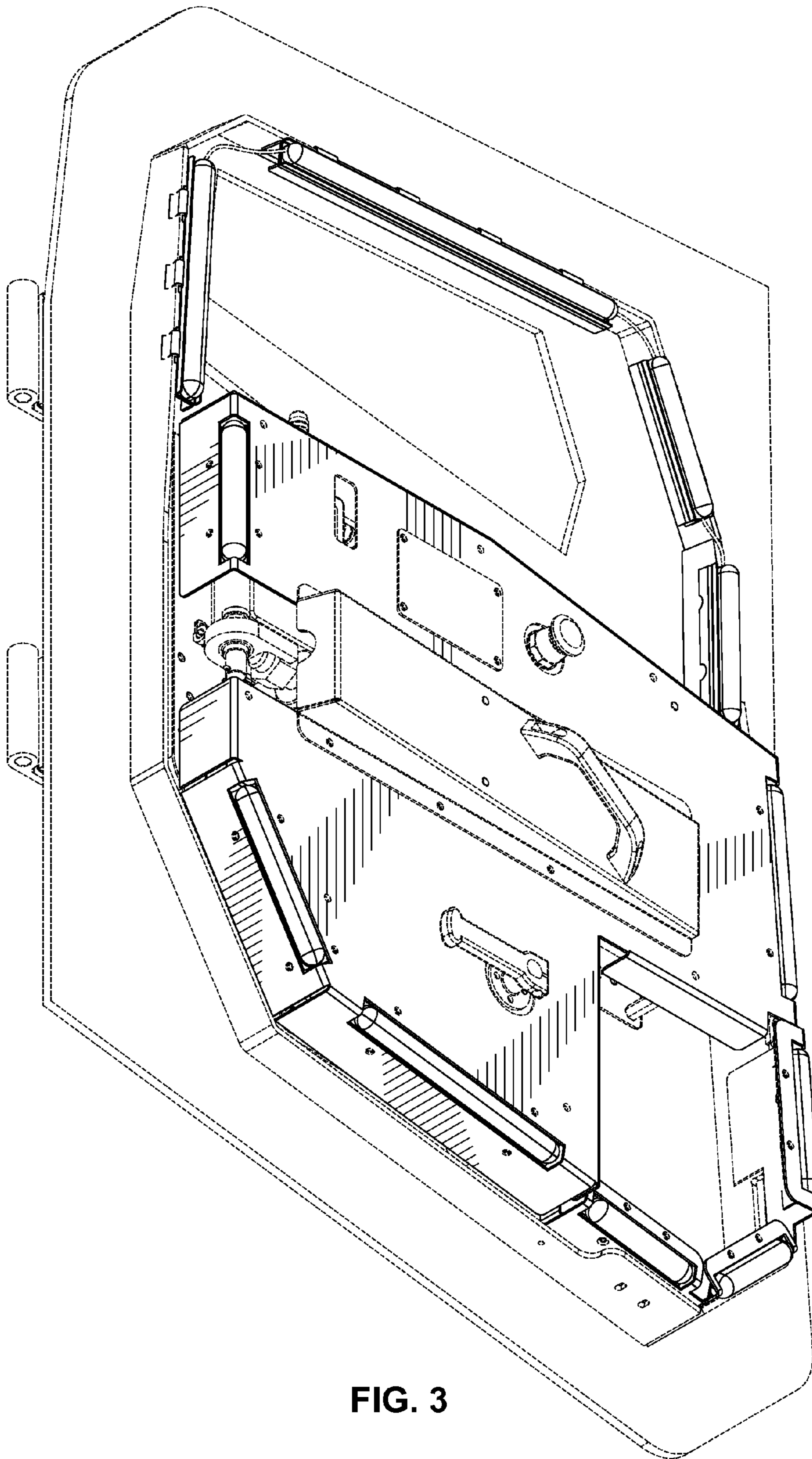

FIG. 3

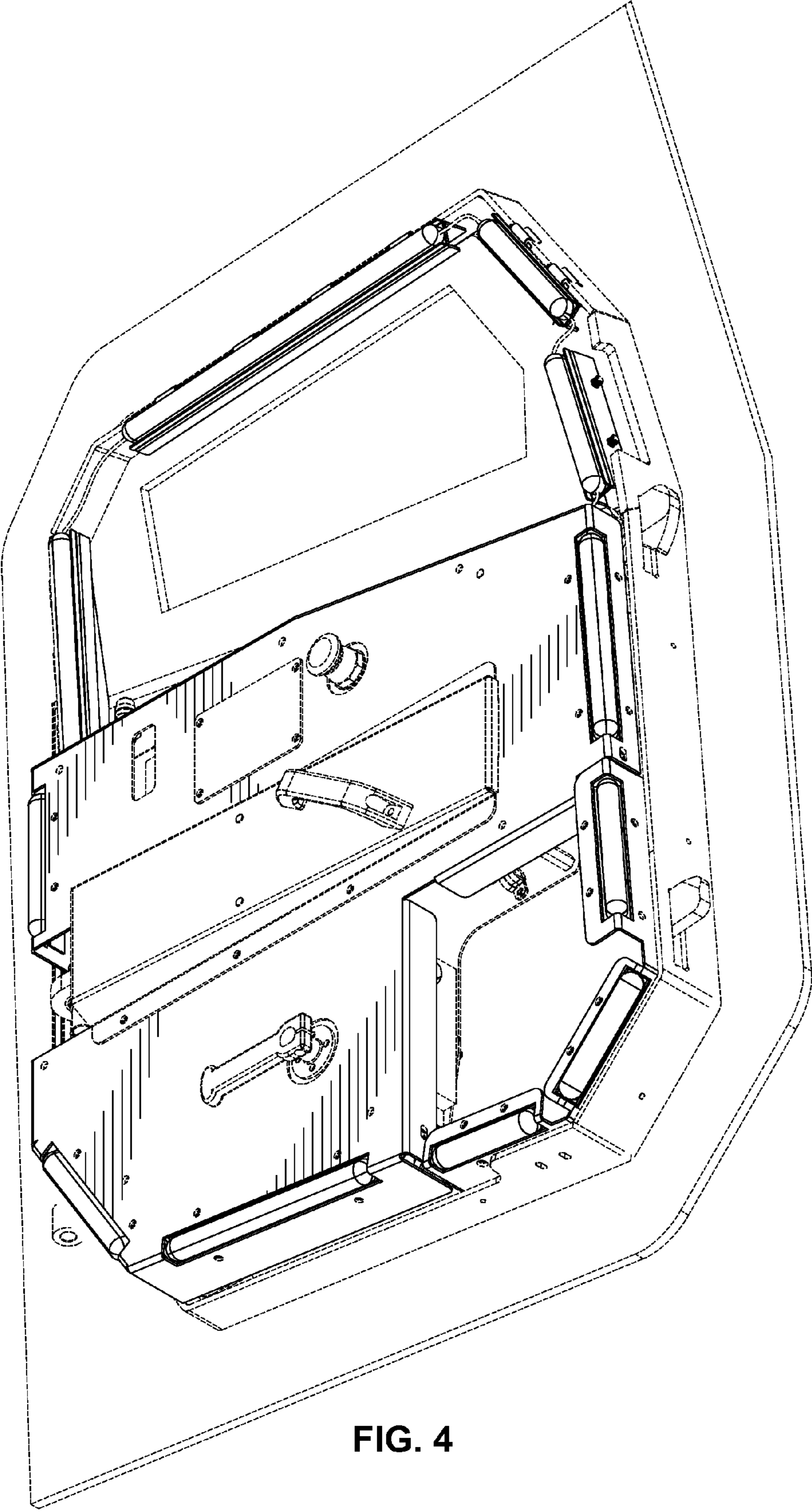

FIG. 4

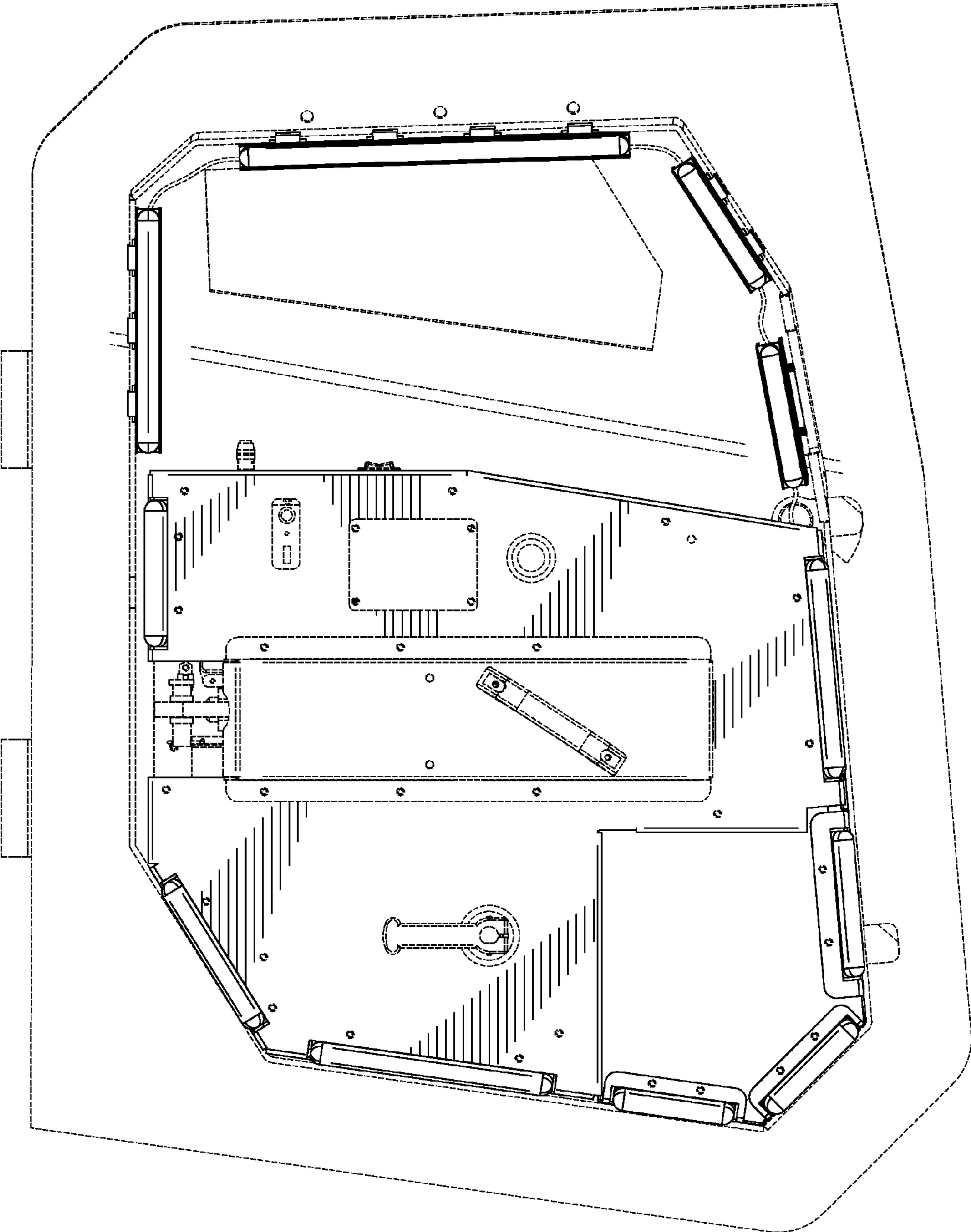

FIG. 5

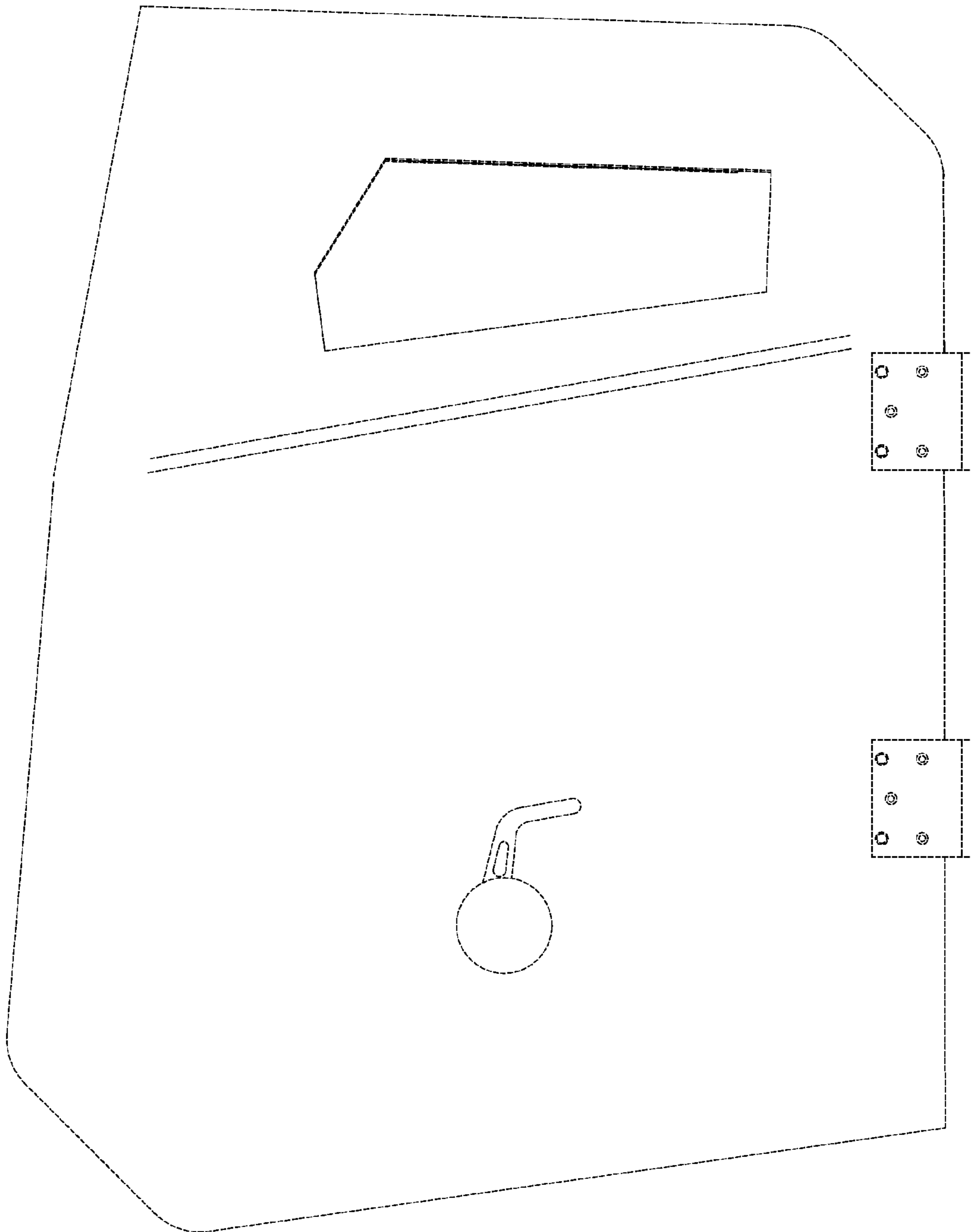

FIG. 6

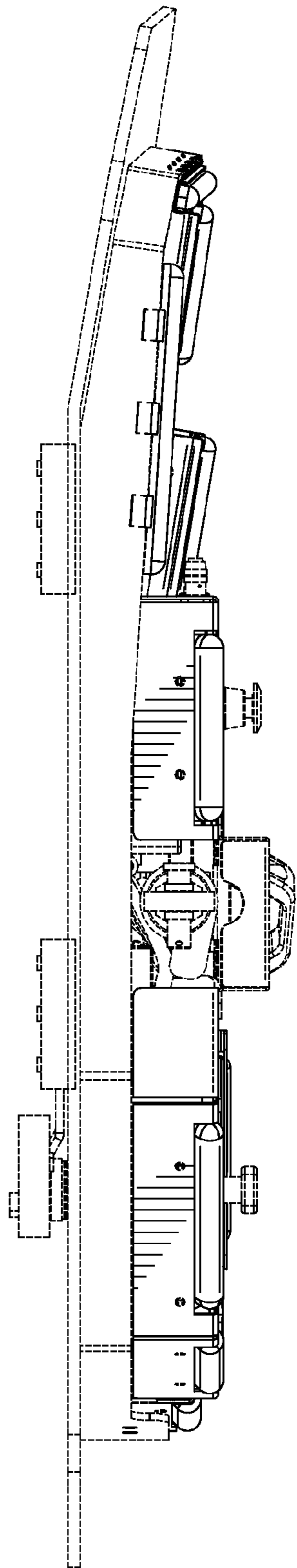

FIG. 7

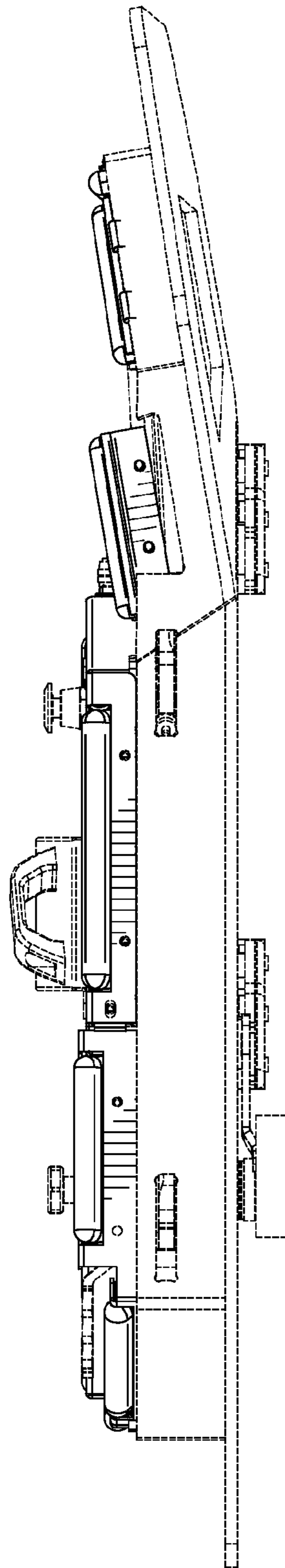

FIG. 8



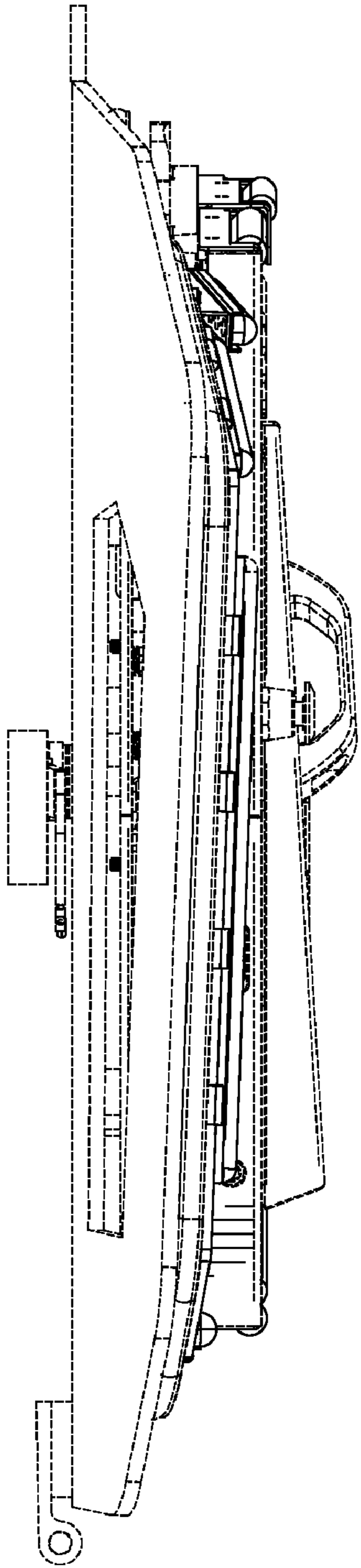

FIG. 9

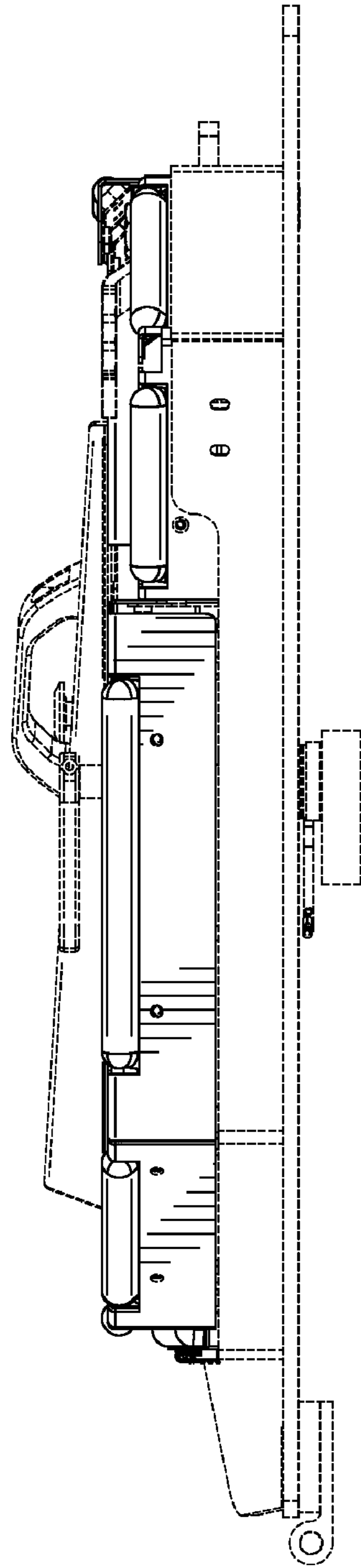

FIG. 10

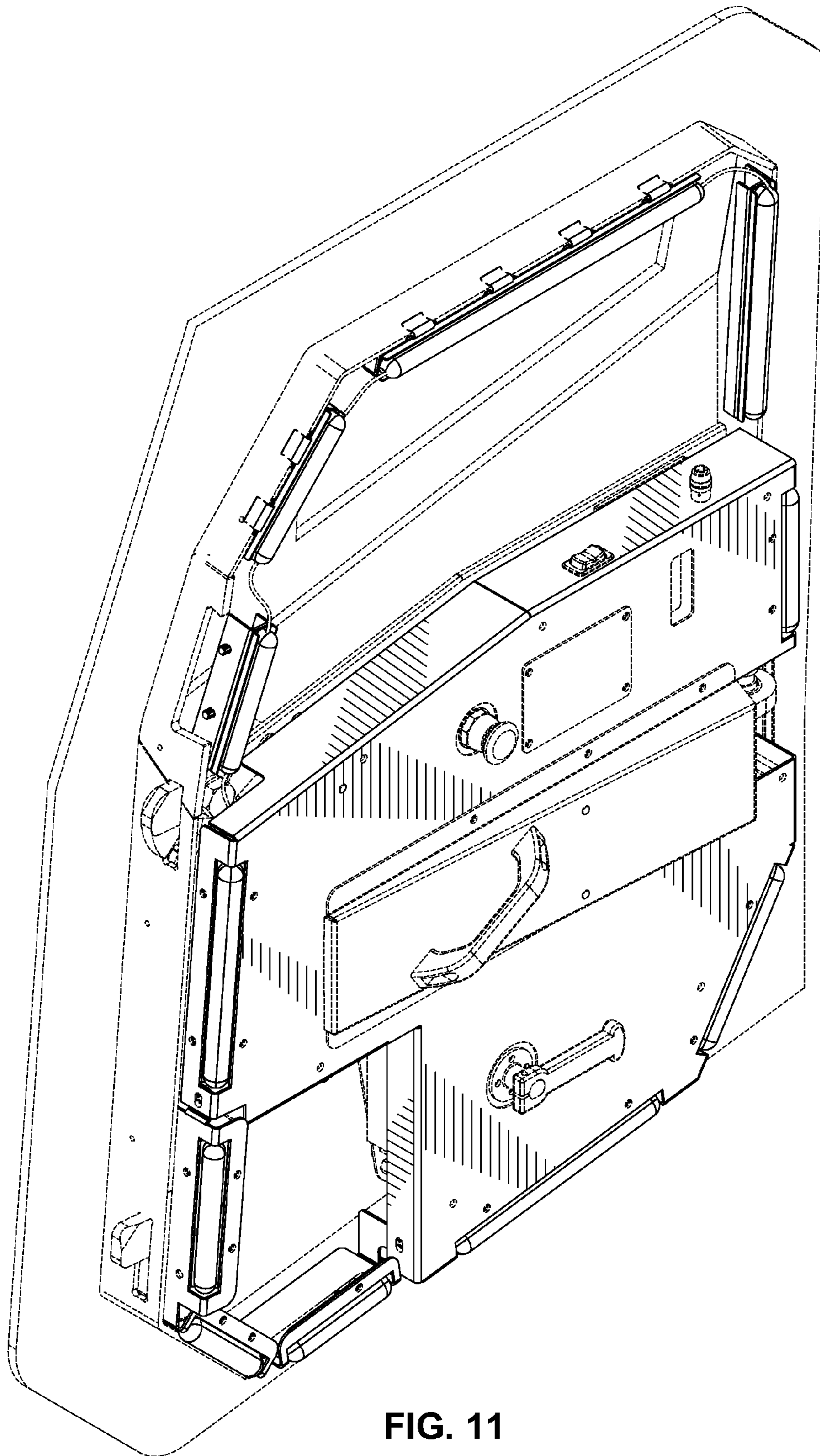

FIG. 11