

US00D626453S

(12) **United States Design Patent**  
**Arnell**

(10) **Patent No.:** **US D626,453 S**

(45) **Date of Patent:** **\*\* Nov. 2, 2010**

(54) **AUTOMOBILE BODY**

D566,004 S \* 4/2008 Teague et al. .... D12/86

(75) Inventor: **Peter Arnell**, Katonah, NY (US)

\* cited by examiner

(73) Assignee: **Chrysler Group LLC**, Auburn Hills, MI (US)

*Primary Examiner*—Robert M Spear

*Assistant Examiner*—Barbara B Lohr

(74) *Attorney, Agent, or Firm*—Ralph E. Smith

(\*\*) Term: **14 Years**

(57) **CLAIM**

(21) Appl. No.: **29/328,125**

The ornamental design for an automobile body, as shown and described.

(22) Filed: **Nov. 19, 2008**

(51) **LOC (9) Cl.** ..... **12-08**

(52) **U.S. Cl.** ..... **D12/86**

(58) **Field of Classification Search** ..... D12/1,  
D12/16, 85, 86, 90, 91, 92, 101, 107; 296/185;  
280/233, 756; D34/34

See application file for complete search history.

**DESCRIPTION**

FIG. 1 is a front perspective view of an automobile body showing our new design;

FIG. 2 is a rear perspective view thereof;

FIG. 3 is a front view thereof;

FIG. 4 a rear view thereof;

FIG. 5 is a side view thereof; and,

FIG. 6 is a top view thereof.

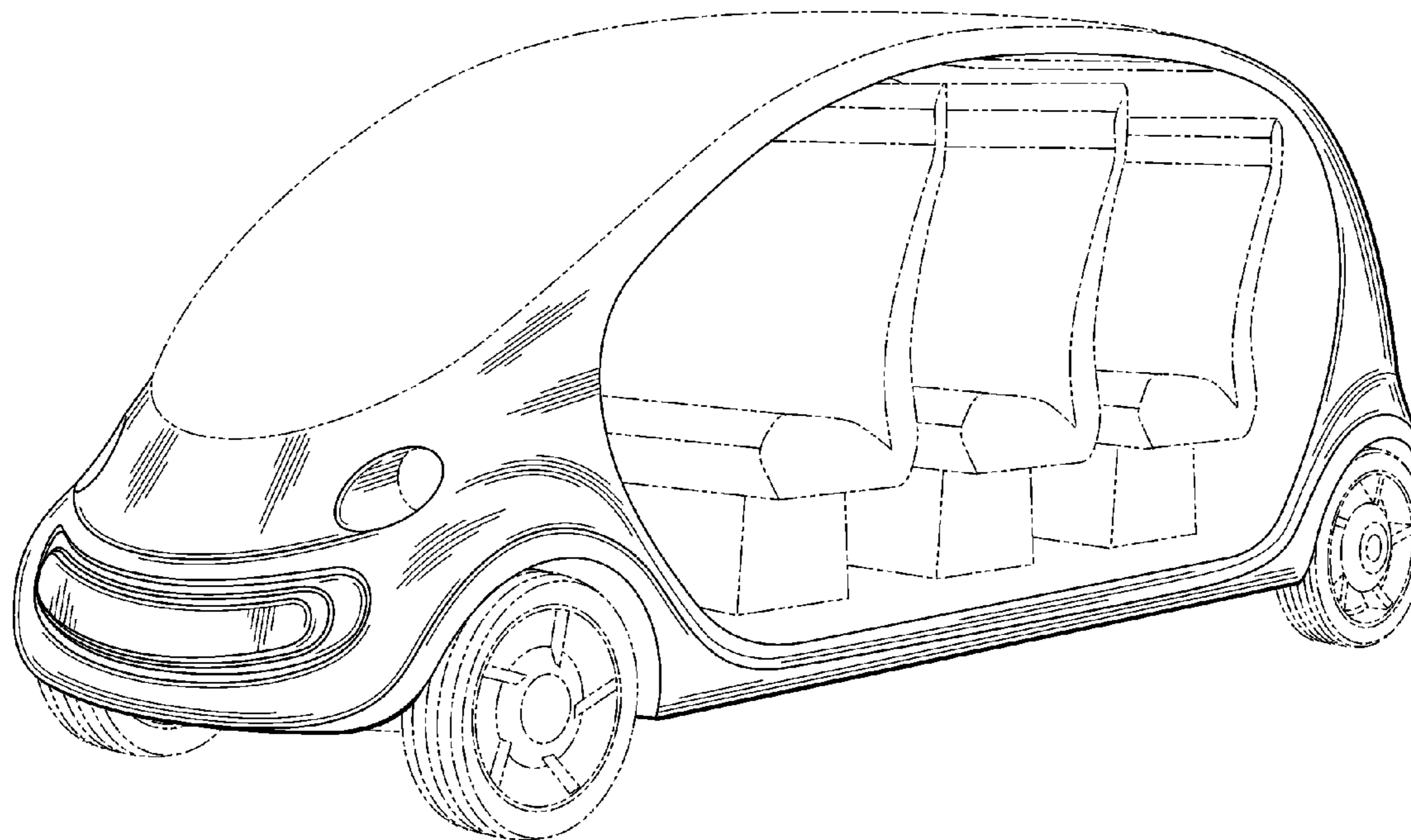
It will be understood that the broken lines presented in the drawings are for illustration only, and do not form a part of the claimed design.

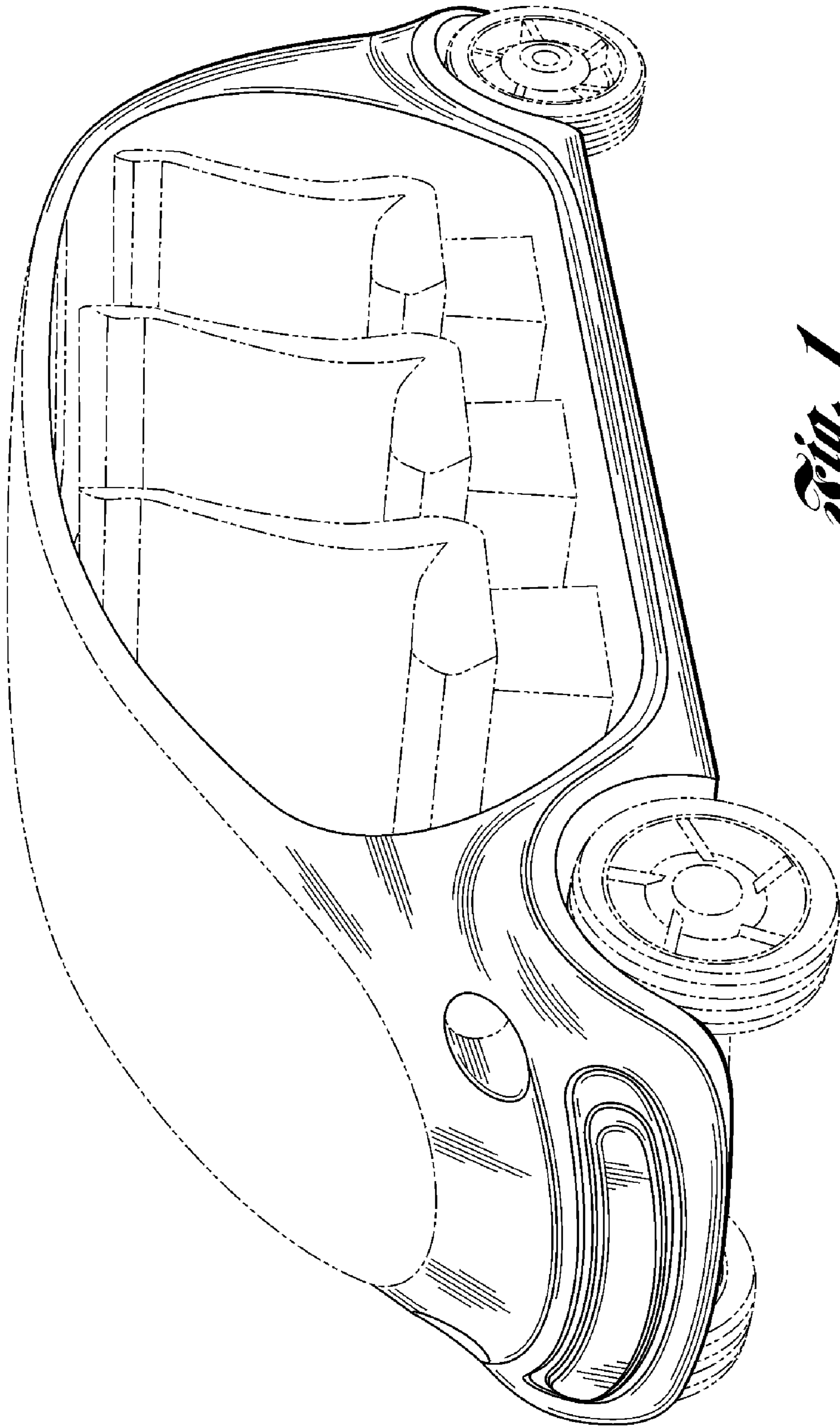
(56) **References Cited**

**U.S. PATENT DOCUMENTS**

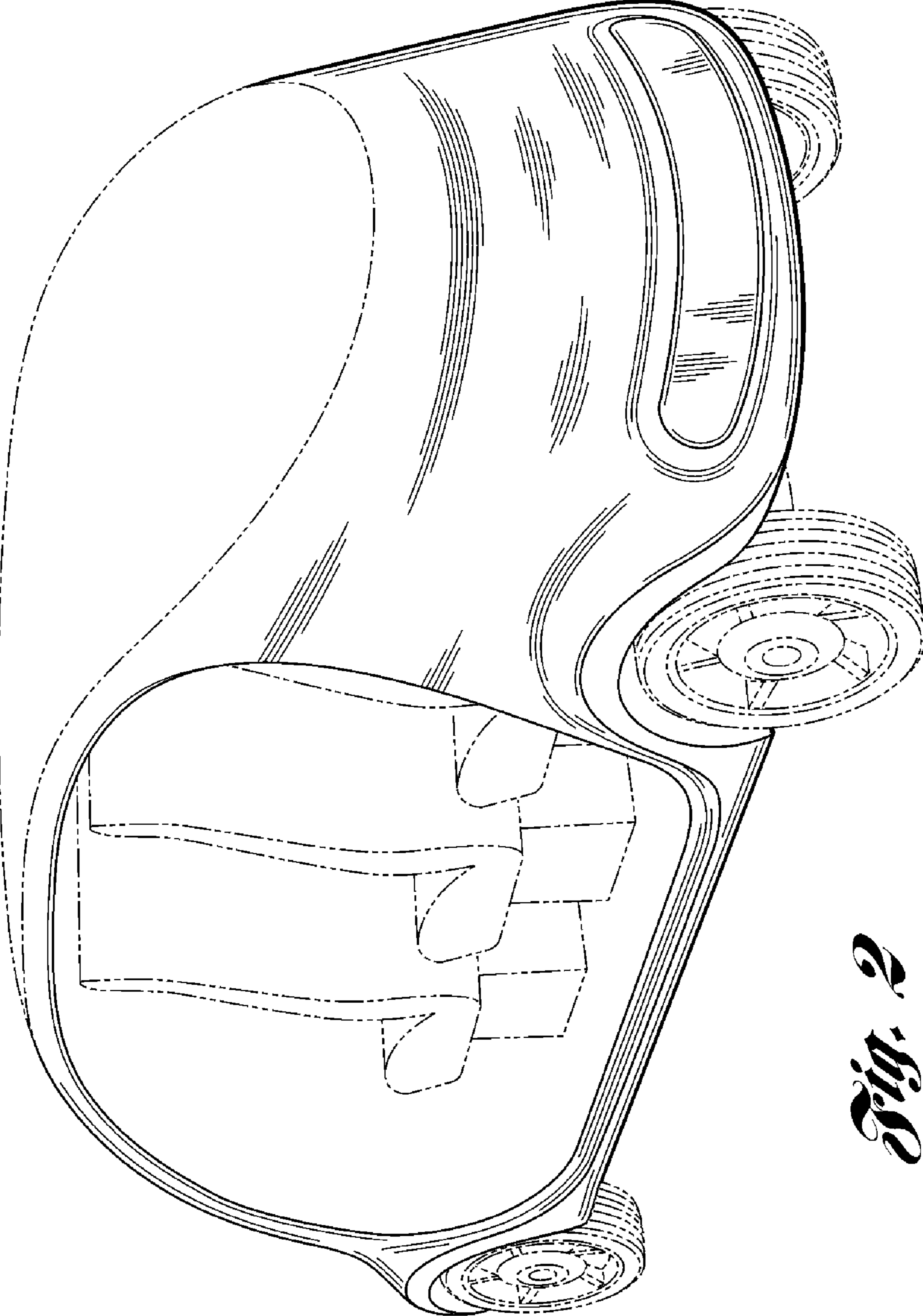
D371,526 S *	7/1996	Verduyn et al. ....	D12/86
D456,311 S *	4/2002	Yamamoto et al. ....	D12/86
D516,957 S *	3/2006	O'Connell et al. ....	D12/91
D551,127 S *	9/2007	Kruger et al. ....	D12/98
D564,946 S *	3/2008	Kruger et al. ....	D12/98

**1 Claim, 5 Drawing Sheets**



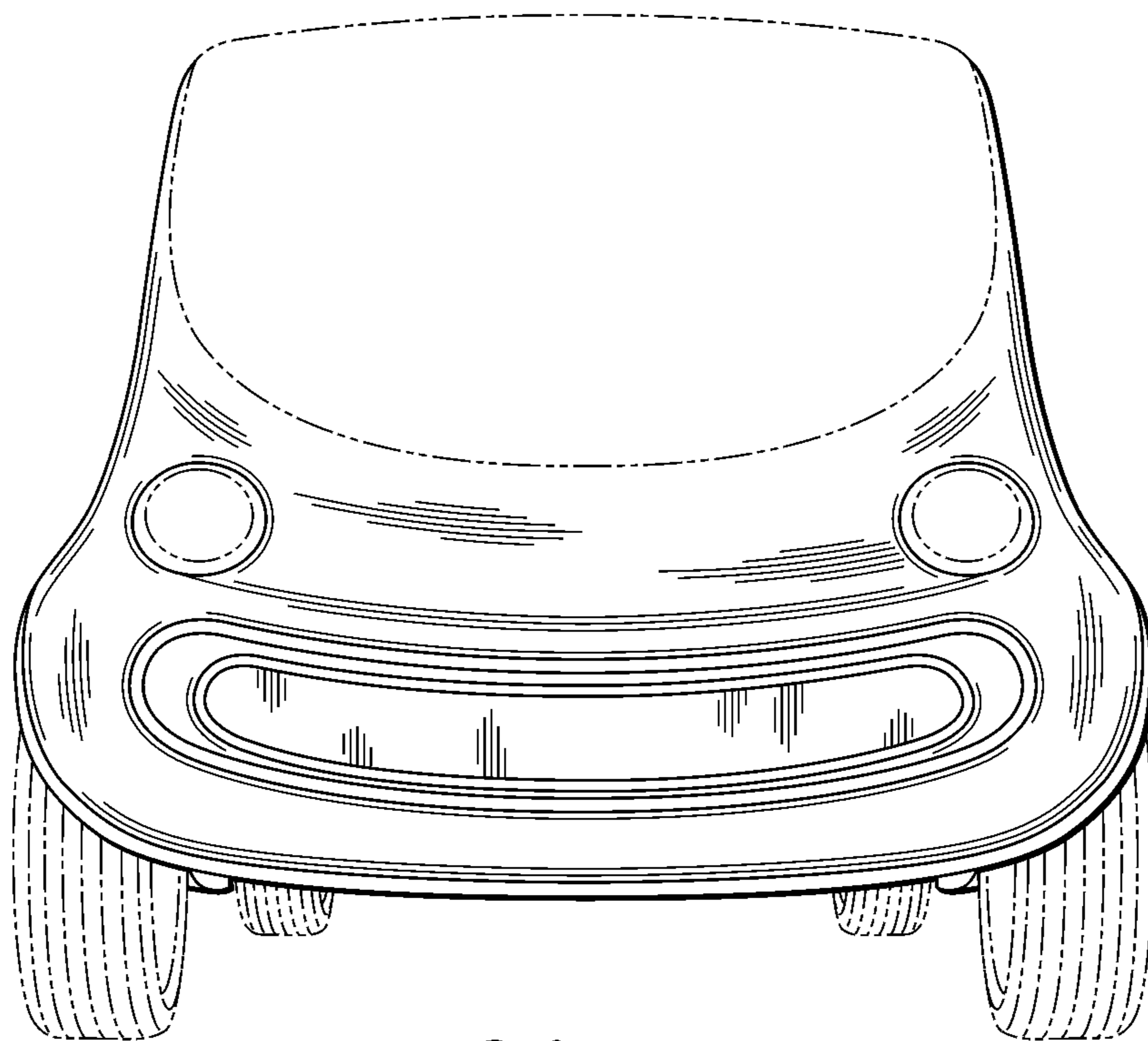


*Fig. 1*

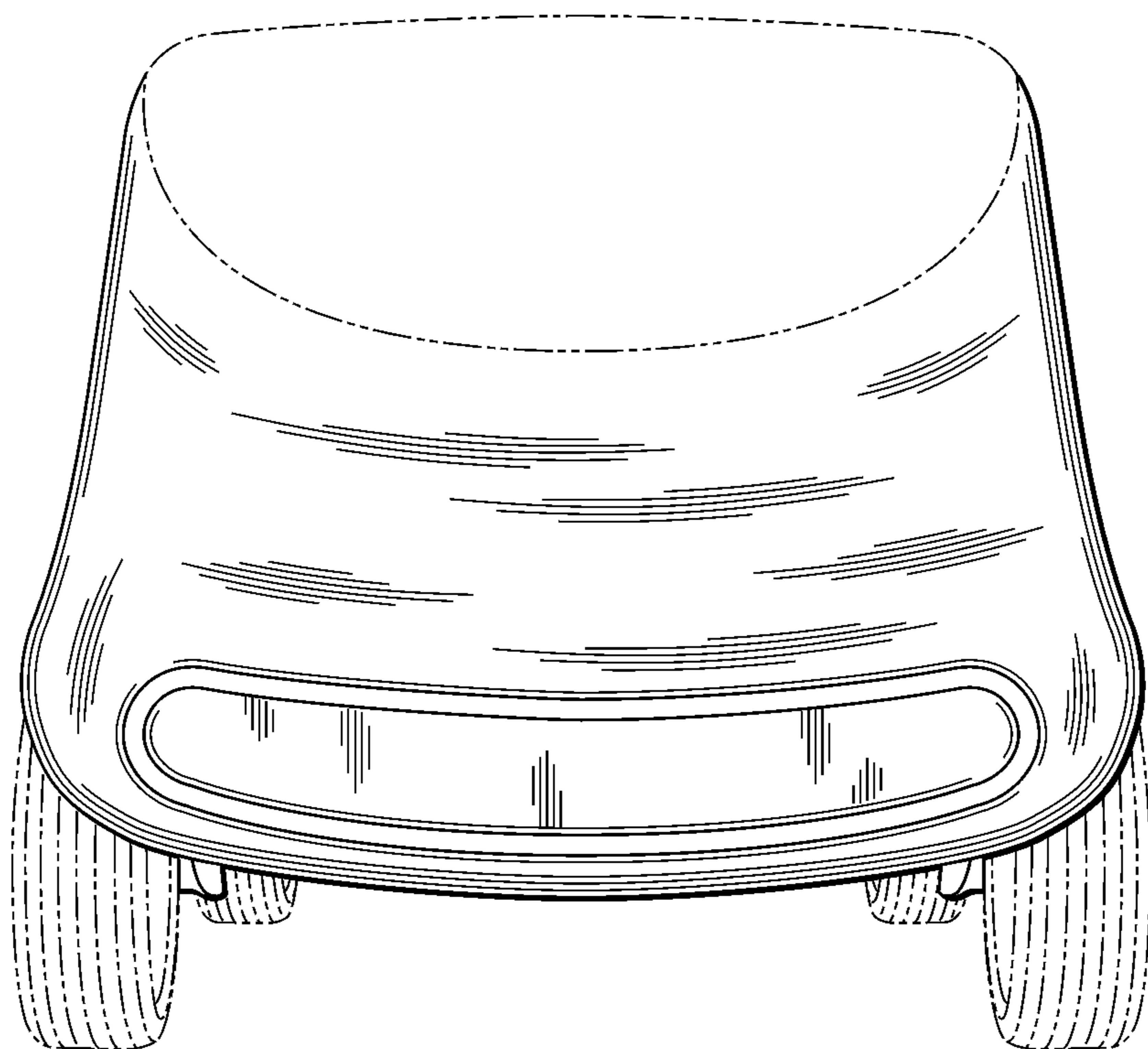


*Fig. 2*

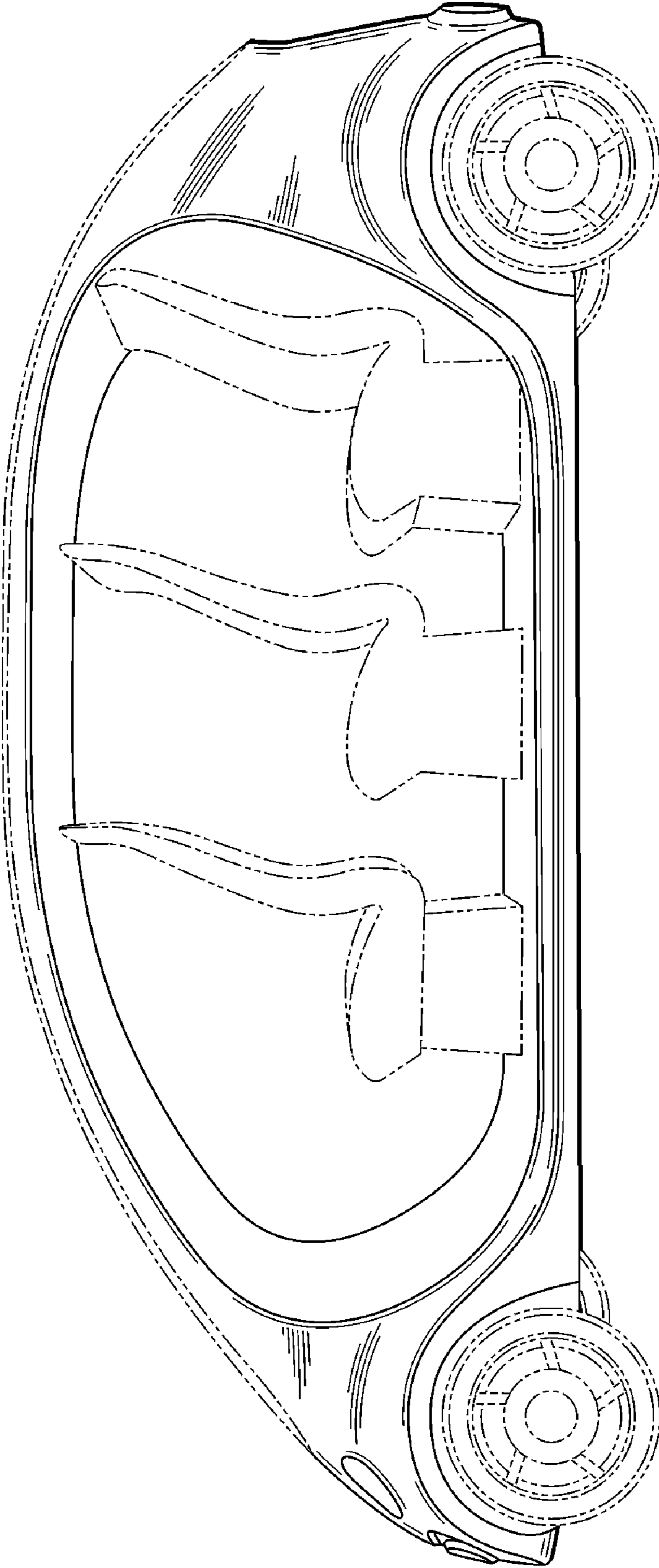




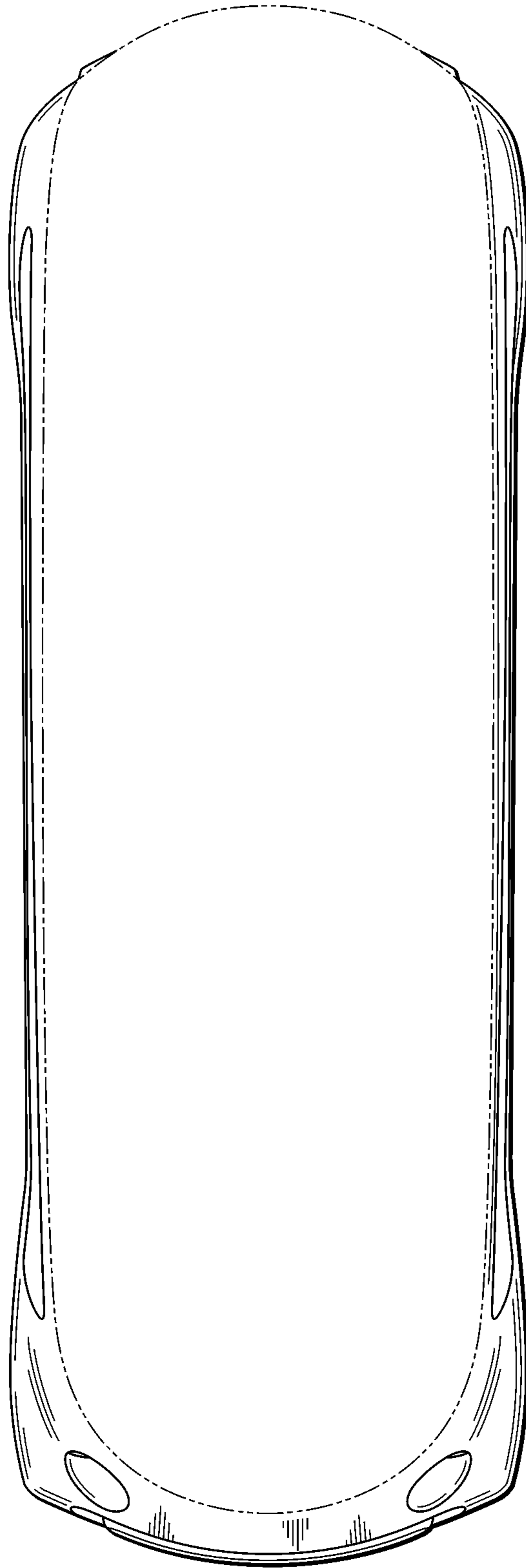
*Fig. 3*



*Fig. 4*



*Fig. 5*



*Fig. 6*