



US00D626156S

(12) **United States Design Patent**
Jebb

(10) **Patent No.:** **US D626,156 S**

(45) **Date of Patent:** **** Oct. 26, 2010**

(54) **COMPOUND MITRE SAW**

(76) **Inventor:** **David Jebb**, Hill Farm, Sleep Hill Lane,
Skelbrooke, Doncaster (GB) DN6 8LZ

(**) **Term:** **14 Years**

(21) **Appl. No.:** **29/339,461**

(22) **Filed:** **Jun. 30, 2009**

(30) **Foreign Application Priority Data**

Mar. 20, 2009 (EM) 001110829-0001

(51) **LOC (9) Cl.** **15-09**

(52) **U.S. Cl.** **D15/133**

(58) **Field of Classification Search** D8/61,
D8/64-69; D15/133, 134; 30/377-378,
30/388-391; 83/377, 378, 388, 397, 468.3,
83/469

See application file for complete search history.

(56) **References Cited**

U.S. PATENT DOCUMENTS

D346,173 S *	4/1994	Price	D15/133
D388,442 S *	12/1997	Shibata et al.	D15/133
D400,215 S *	10/1998	Price et al.	D15/133
D421,267 S *	2/2000	Price et al.	D15/133
D455,445 S *	4/2002	Bean et al.	D15/133
D459,373 S *	6/2002	Hollinger et al.	D15/133
D478,103 S *	8/2003	Kani et al.	D15/133
D479,251 S *	9/2003	Wright	D15/133
D487,280 S *	3/2004	Hon et al.	D15/133
D487,754 S *	3/2004	Kao	D15/133
D490,826 S *	6/2004	Wu	D15/133

D513,271 S *	12/2005	Ozawa et al.	D15/133
D597,569 S *	8/2009	Sasaki et al.	D15/133
2009/0235794 A1 *	9/2009	Inai	83/397

* cited by examiner

Primary Examiner—Patricia Palasik

(74) *Attorney, Agent, or Firm*—Sonnenschein Nath &
Rosenthal LLP; Brian R. McGinley

(57) **CLAIM**

The ornamental design for a compound mitre saw, as shown
and described.

DESCRIPTION

FIG. 1 is a perspective of a compound mitre saw embodying
the new design;

FIG. 2 is a rear view of the compound mitre saw illustrated in
FIG. 1;

FIG. 3 is a front view of the compound mitre saw illustrated
in FIG. 1;

FIG. 4 is a left side view of the compound mitre saw illus-
trated in FIG. 1;

FIG. 5 is a right side view of the compound mitre saw shown
in FIG. 1;

FIG. 6 is a top view of the compound mitre saw illustrated in
FIG. 1; and,

FIG. 7 is a bottom view of the compound mitre saw illustrated
in FIG. 1.

The broken lines in the drawings depict unclaimed environ-
mental subject matter.

1 Claim, 7 Drawing Sheets

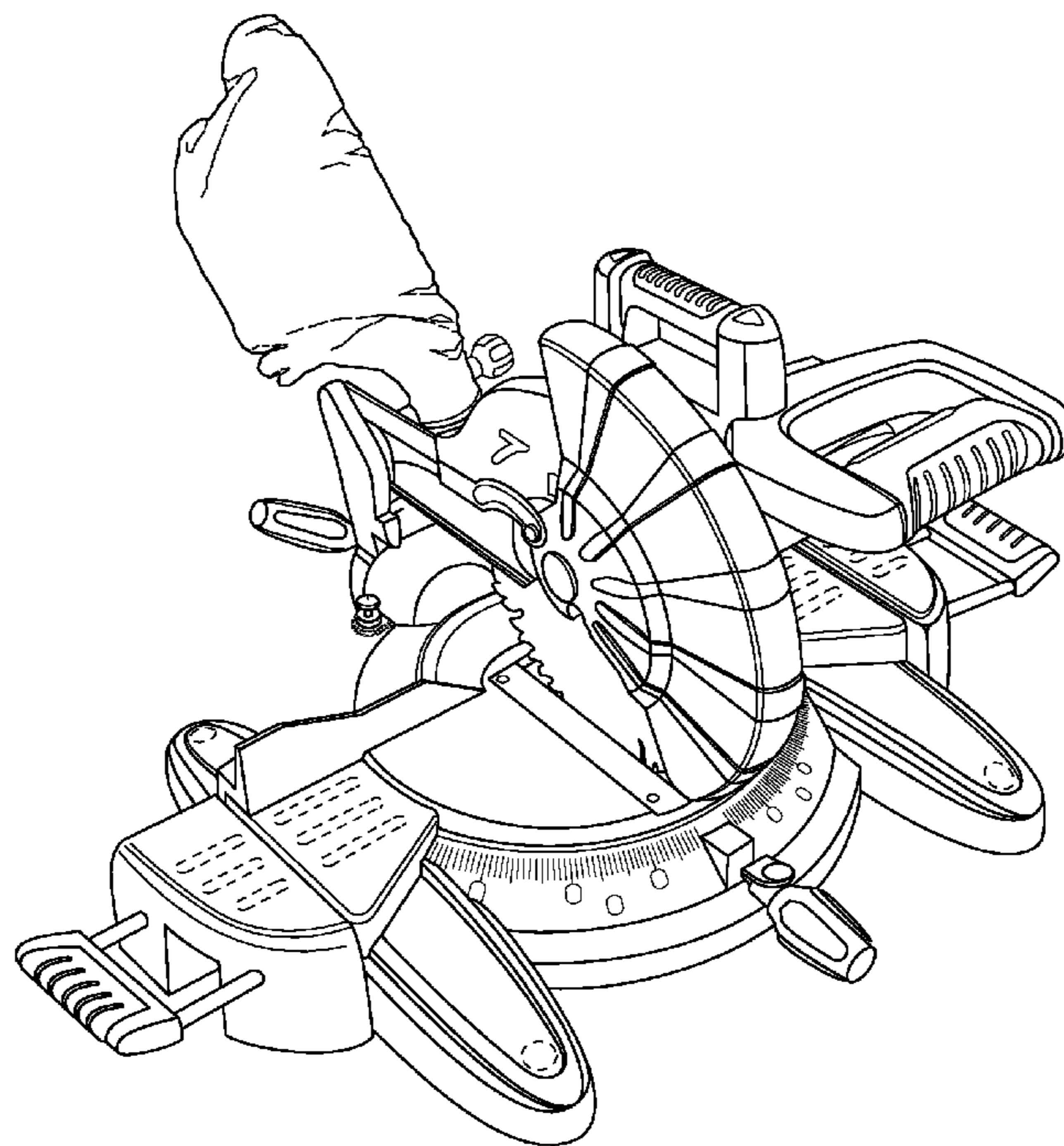

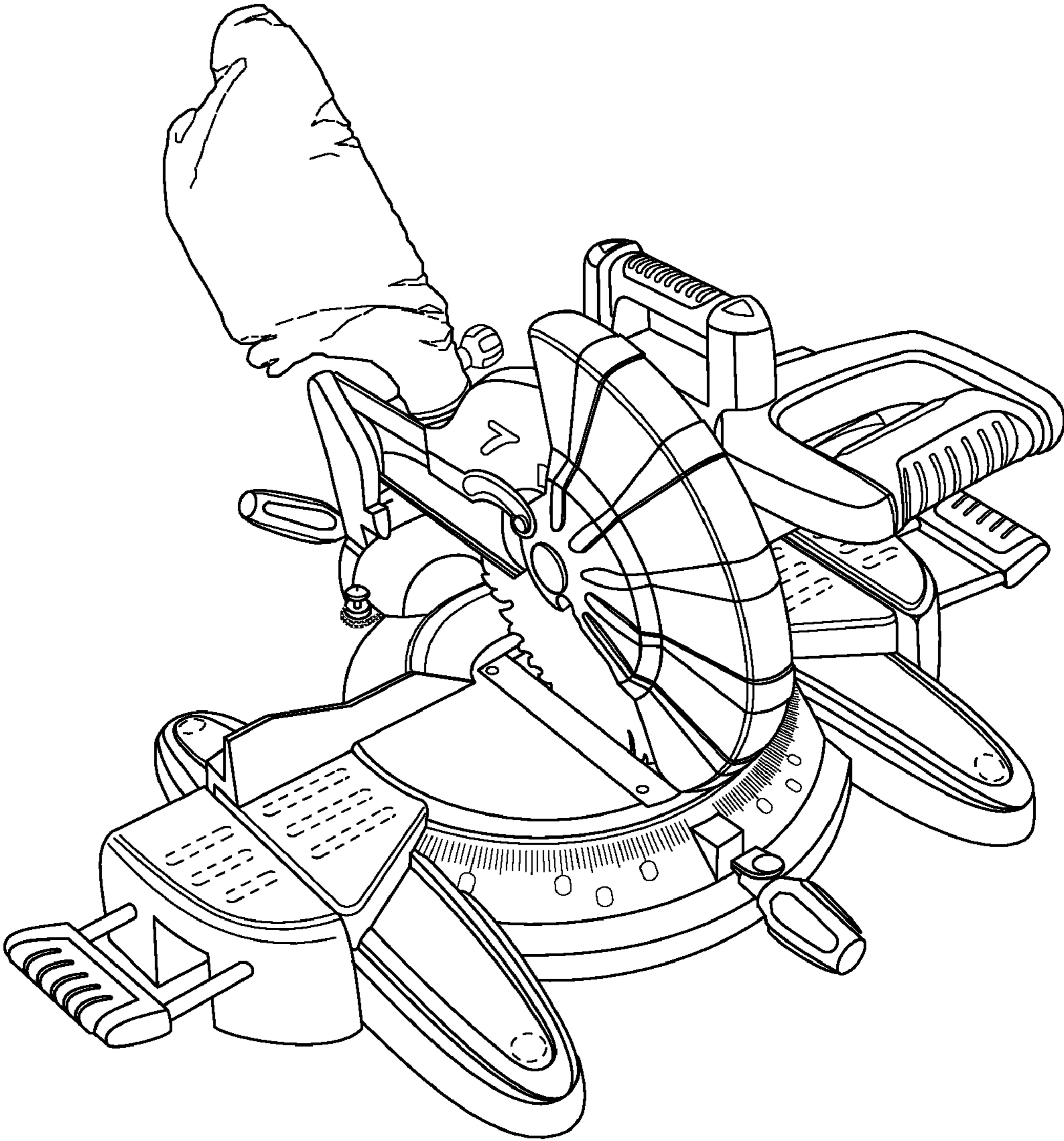

FIG. 1

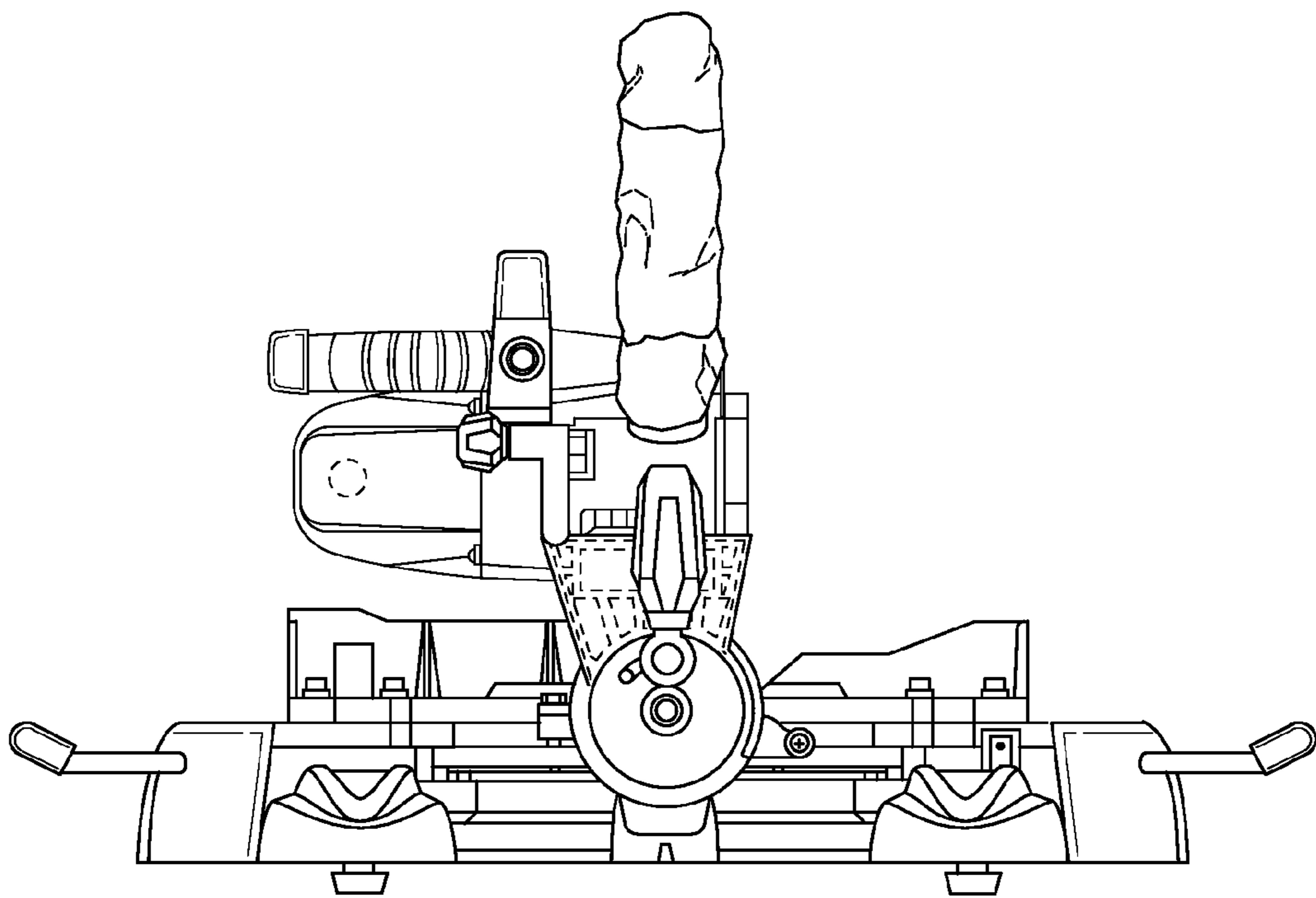

FIG. 2

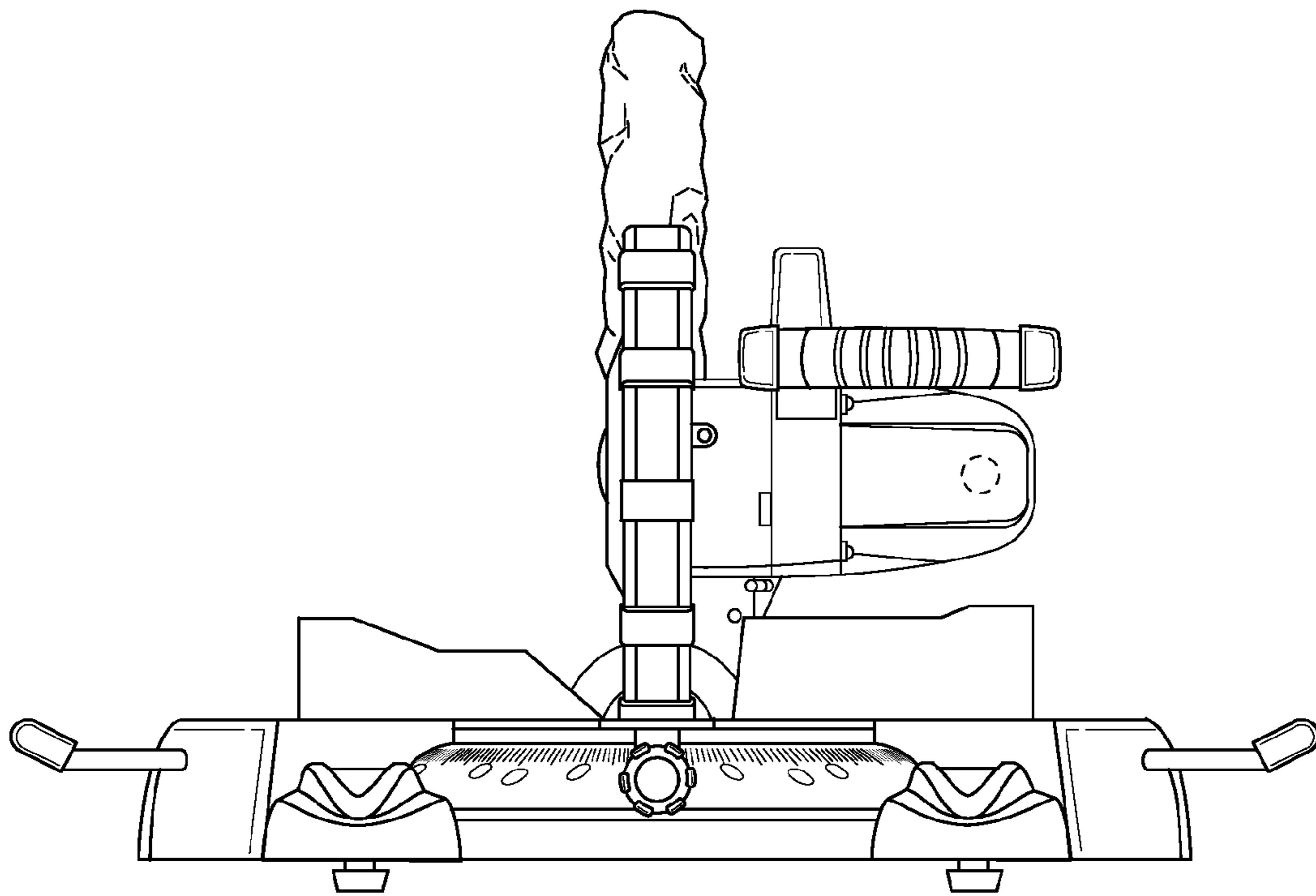

FIG. 3

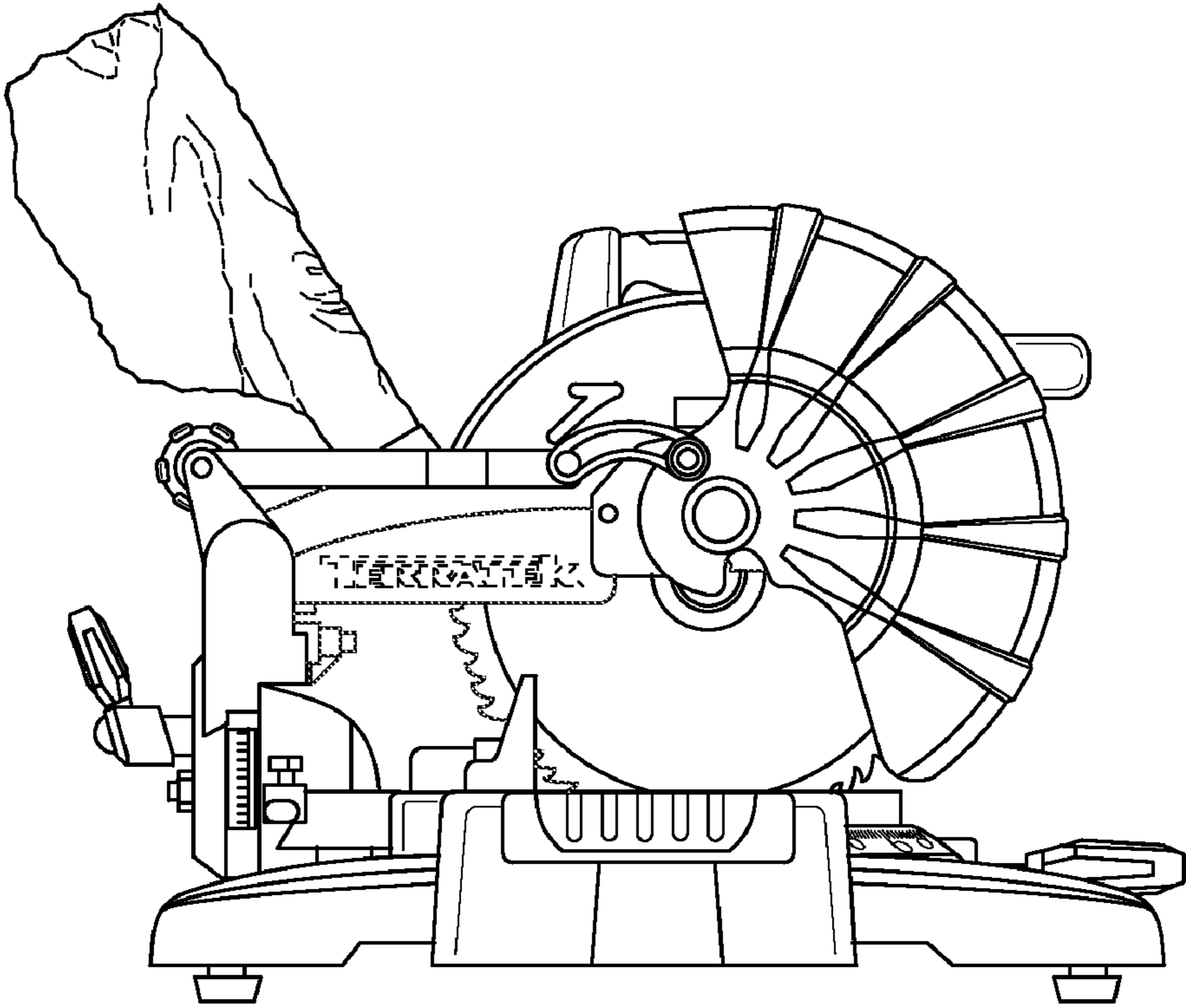

FIG. 4

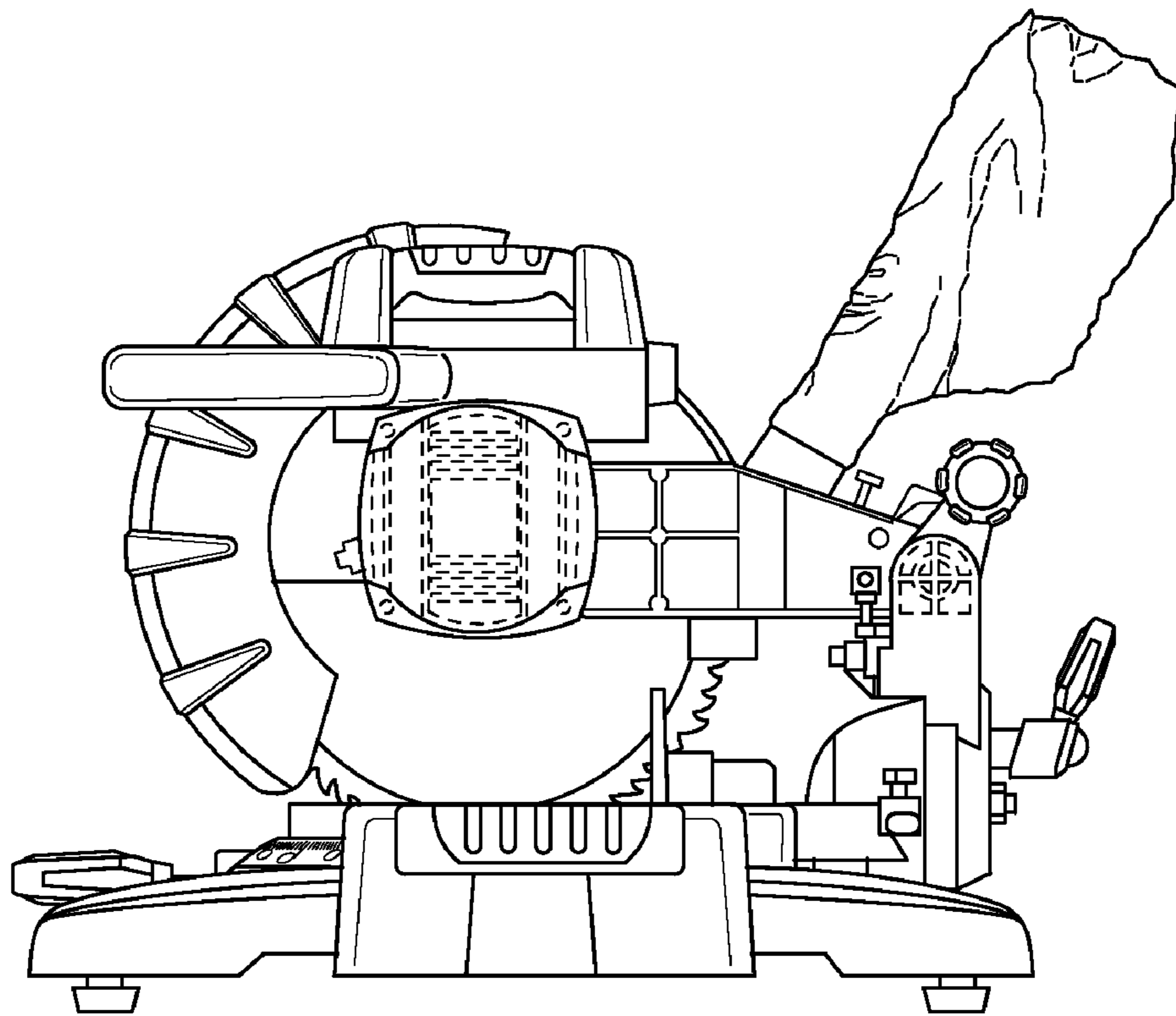

FIG. 5

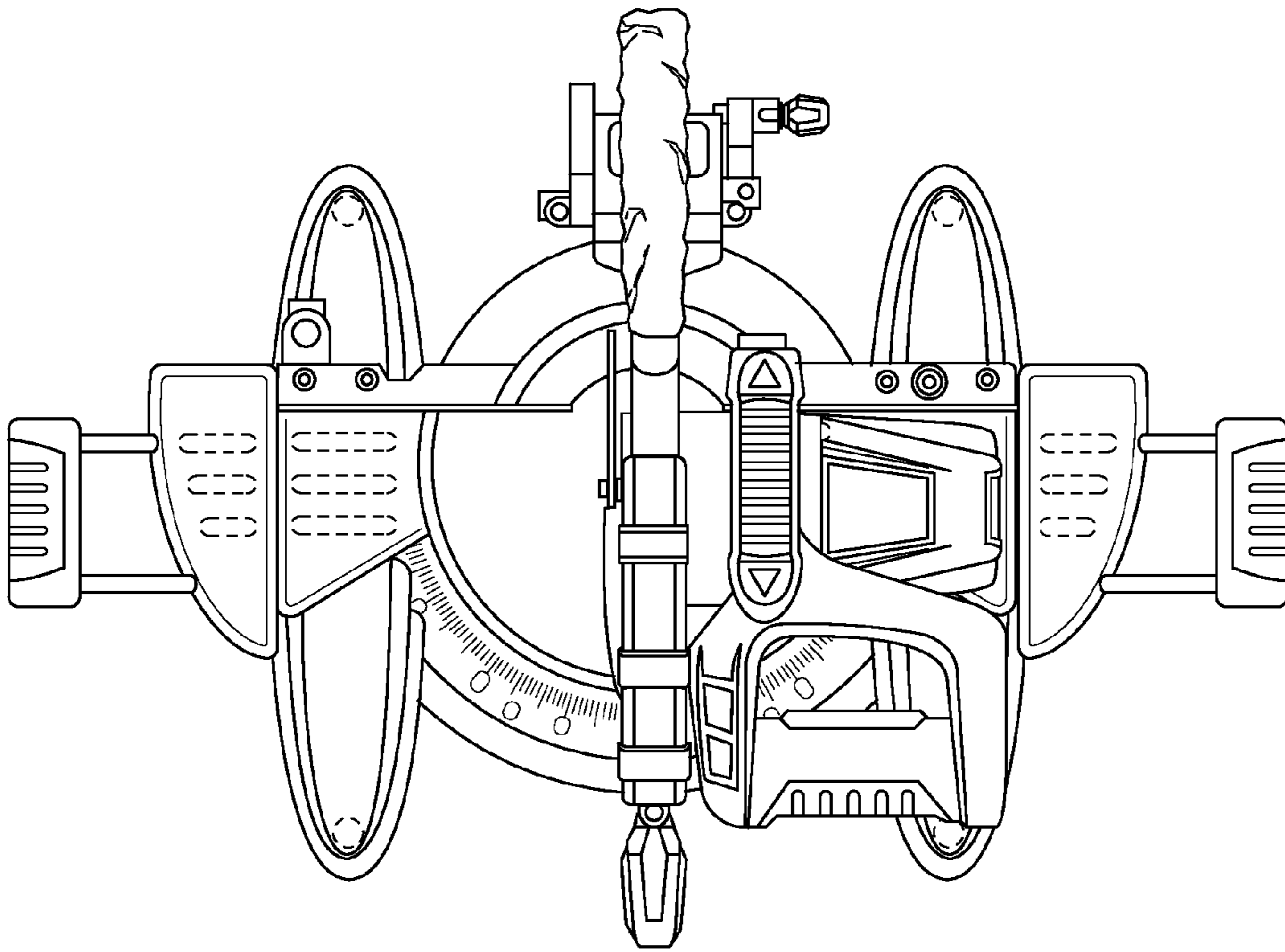

FIG. 6

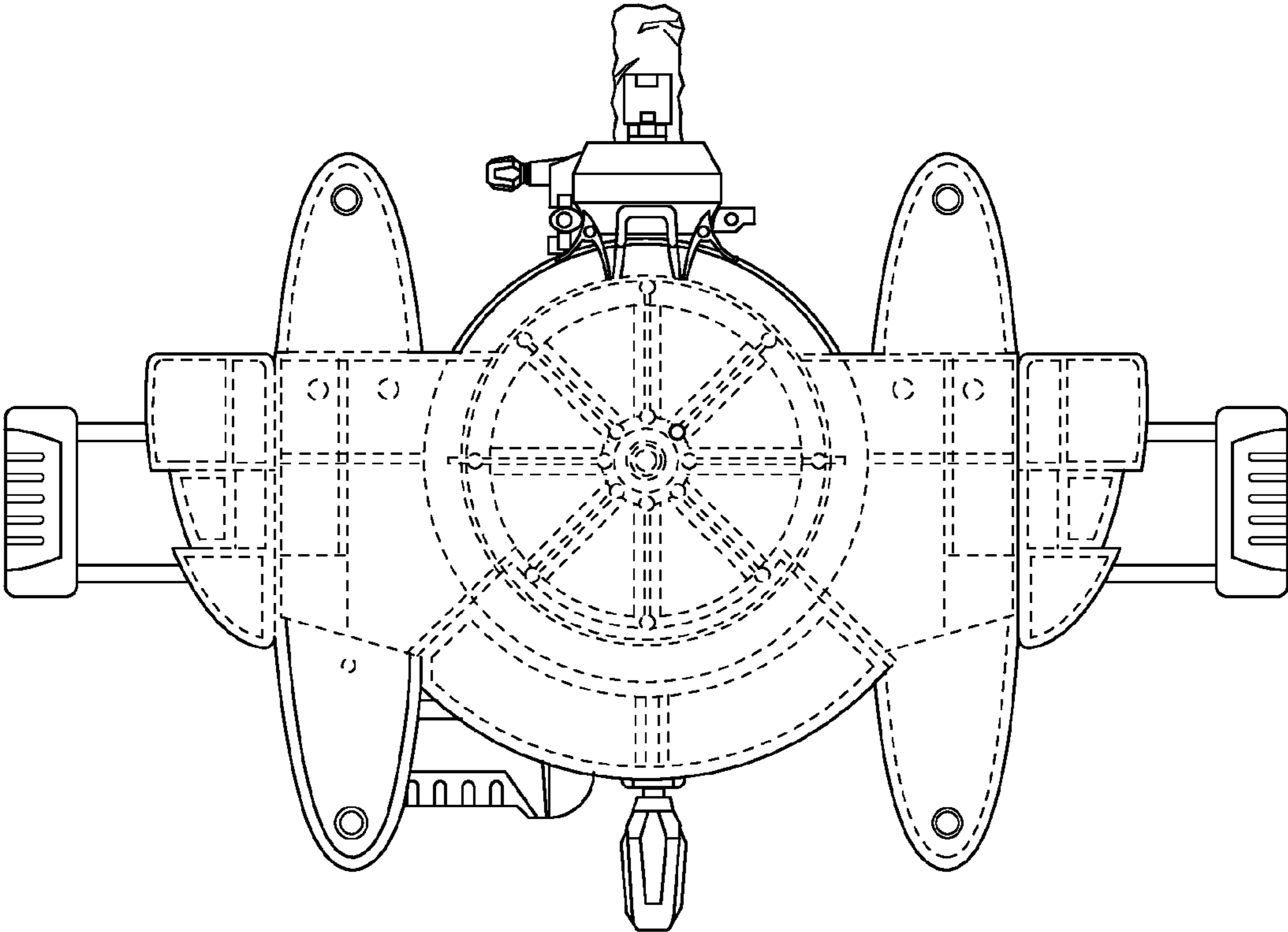

FIG. 7