



US00D626031S

(12) **United States Design Patent**  
**Doran**

(10) **Patent No.:** **US D626,031 S**

(45) **Date of Patent:** **\*\* Oct. 26, 2010**

(54) **ELECTRICALLY POWERED VEHICLE**

D551,722 S \* 9/2007 Chang et al. .... D21/421  
D587,173 S \* 2/2009 Laymaster .... D12/128

(76) Inventor: **Rick Doran**, 5842 McFadden Ave., Unit  
R, Huntington Beach, CA (US) 92649

\* cited by examiner

(\*\*) Term: **14 Years**

*Primary Examiner*—T. Chase Nelson  
*Assistant Examiner*—Ania K Dworzecka

(21) Appl. No.: **29/312,582**

(74) *Attorney, Agent, or Firm*—Roy A. Ekstrand

(22) Filed: **Oct. 30, 2008**

(57) **CLAIM**

(51) **LOC (9) Cl.** ..... **12-14**

The ornamental design for an electrically powered vehicle, as shown and described.

(52) **U.S. Cl.** ..... **D12/1**

(58) **Field of Classification Search** ..... D12/1,  
D12/110–113, 6–11, 128, 129, 130; D21/419–435,  
D21/766–767, 769, 760, 765, 764; 280/87.1,  
280/87.021, 87.041, 263, 288.1, 288.2, 200,  
280/210, 214, 29, 14.27, 14.28, 28.11, 603–607;  
180/180, 181, 65.1

**DESCRIPTION**

See application file for complete search history.

FIG. 1 is a top plan view of an electrically powered vehicle showing my new design;

FIG. 2 is a rear elevation view thereof;

FIG. 3 is a bottom plan view thereof;

FIG. 4 is a front elevation view thereof;

FIG. 5 is a right side elevation view thereof; and,

FIG. 6 is a left side elevation view thereof.

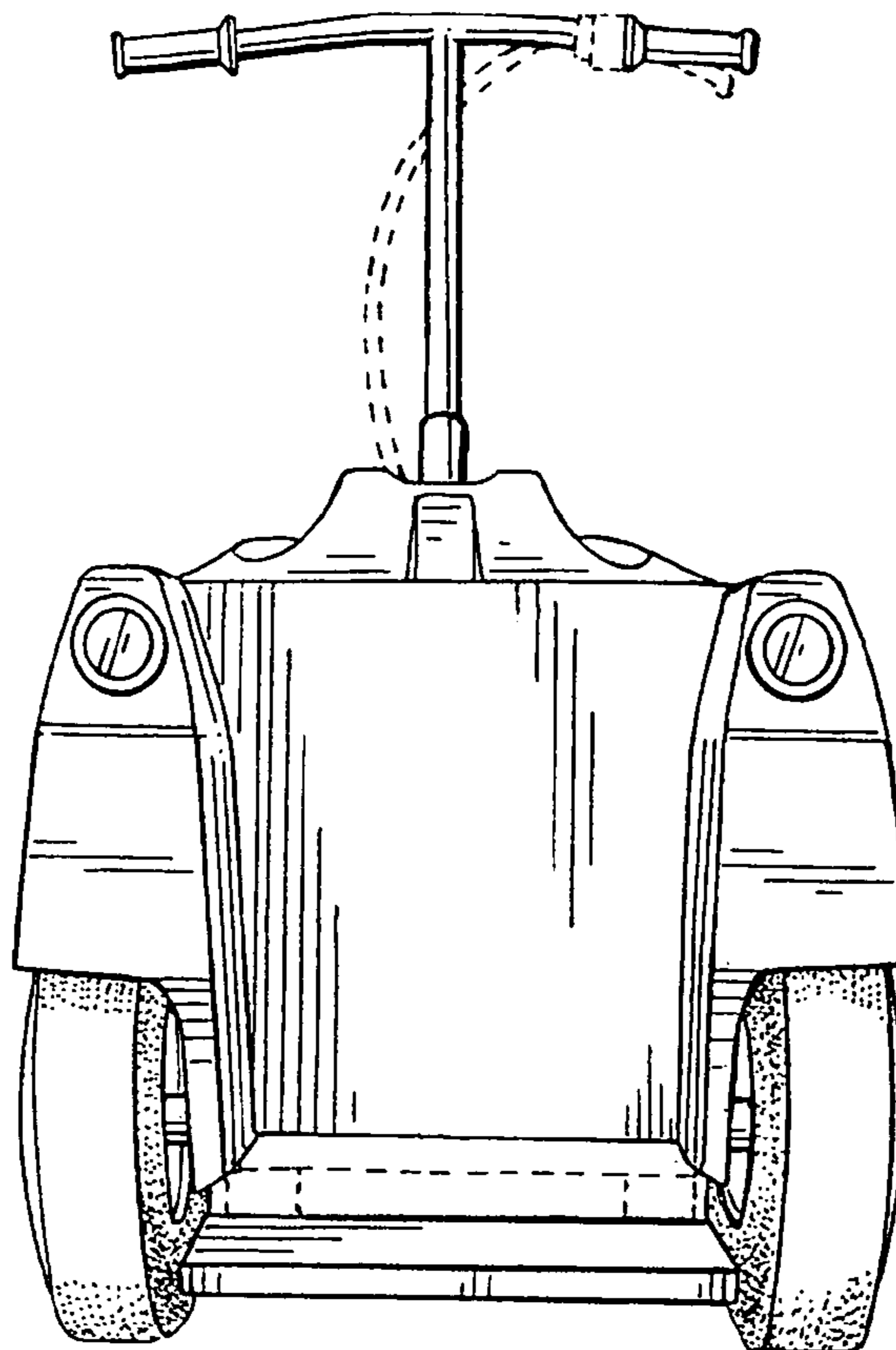
In the drawings, the broken lines depict unclaimed subject matter only and form no part of the claimed design.

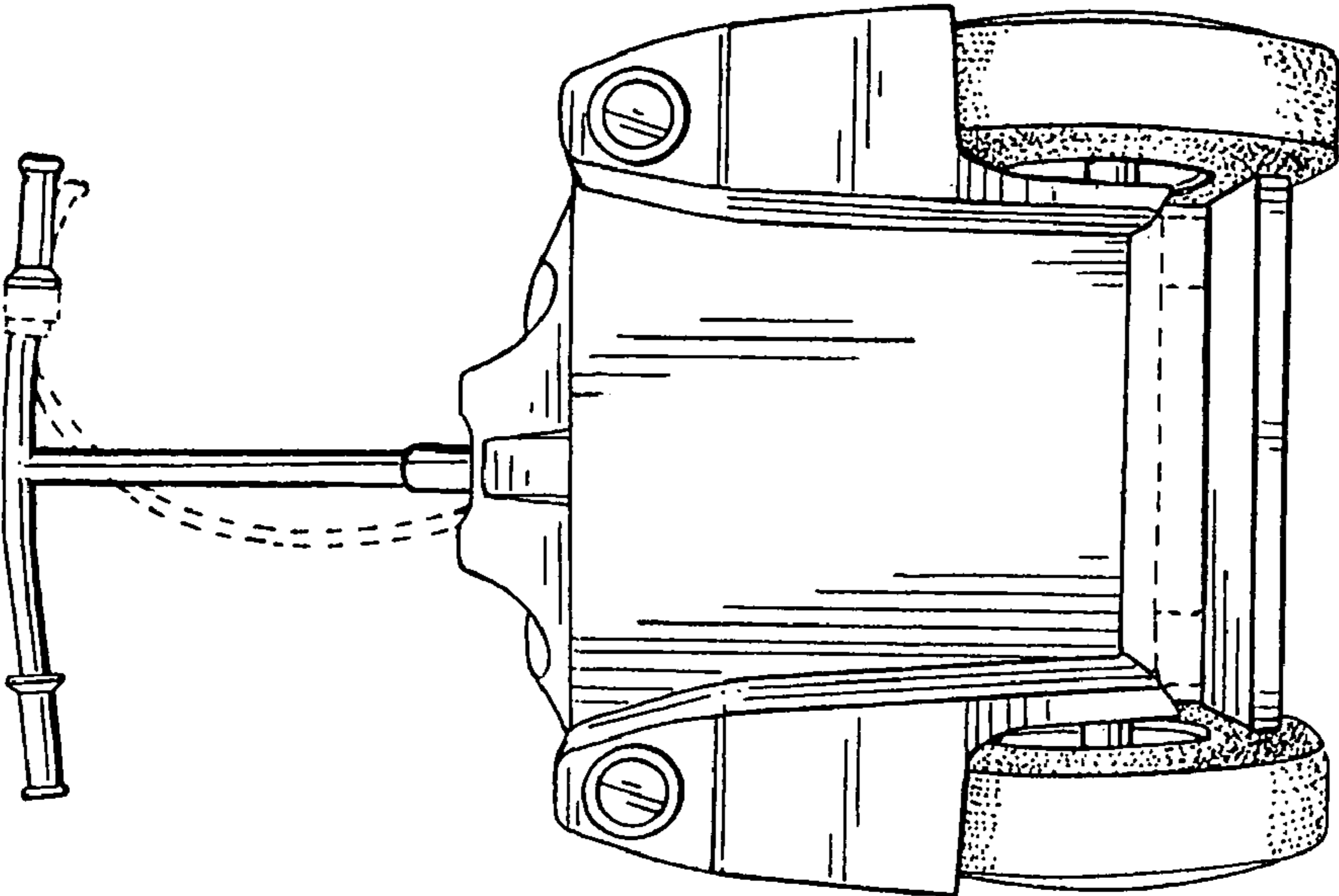
(56) **References Cited**

**U.S. PATENT DOCUMENTS**

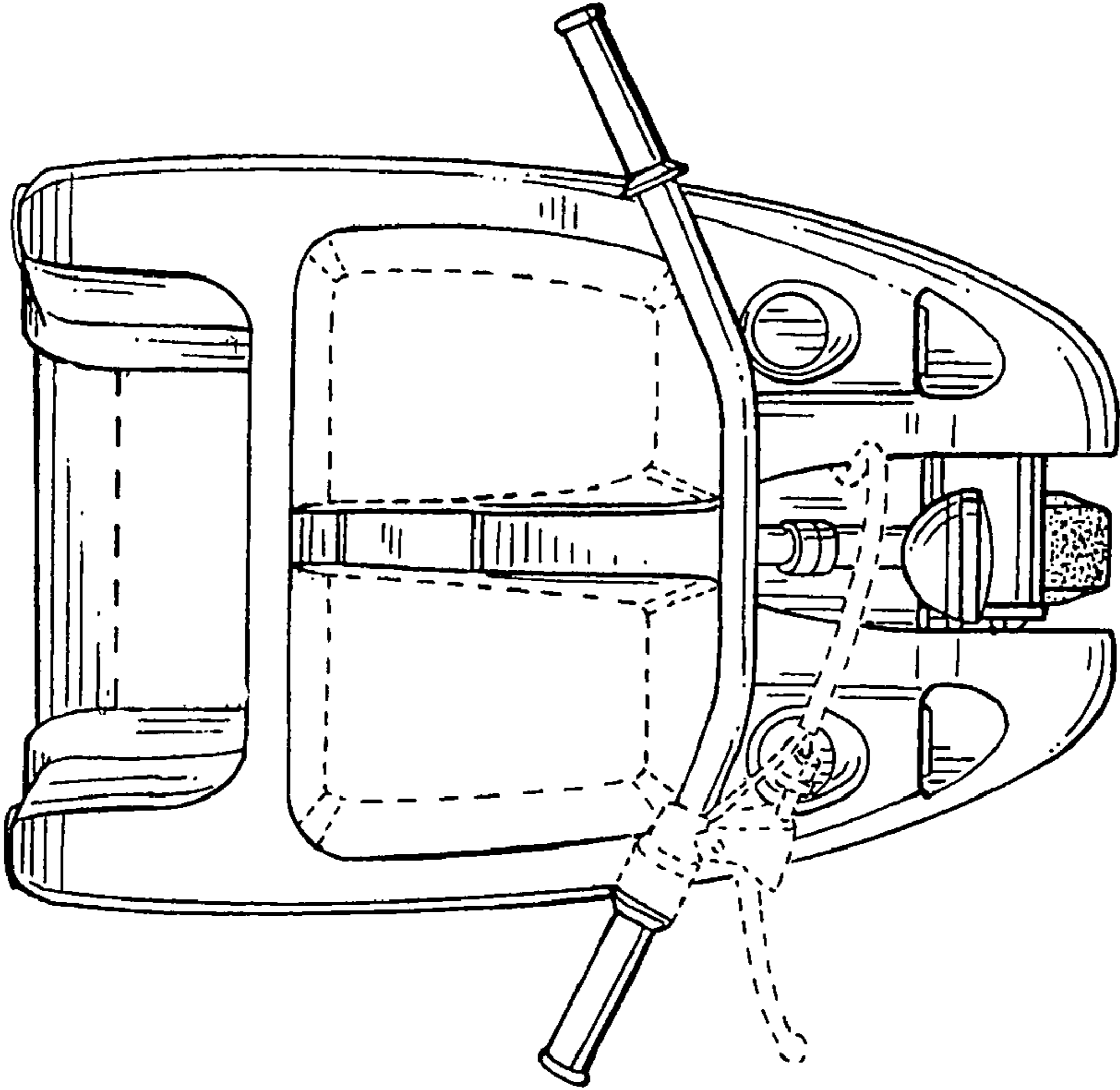
D199,384 S \* 10/1964 Laher ..... D12/85  
D355,148 S \* 2/1995 Orsolini ..... D12/85  
D507,206 S \* 7/2005 Wang ..... D12/1  
D528,468 S \* 9/2006 Arling et al. .... D12/1  
D551,592 S \* 9/2007 Chang et al. .... D12/1

**1 Claim, 3 Drawing Sheets**

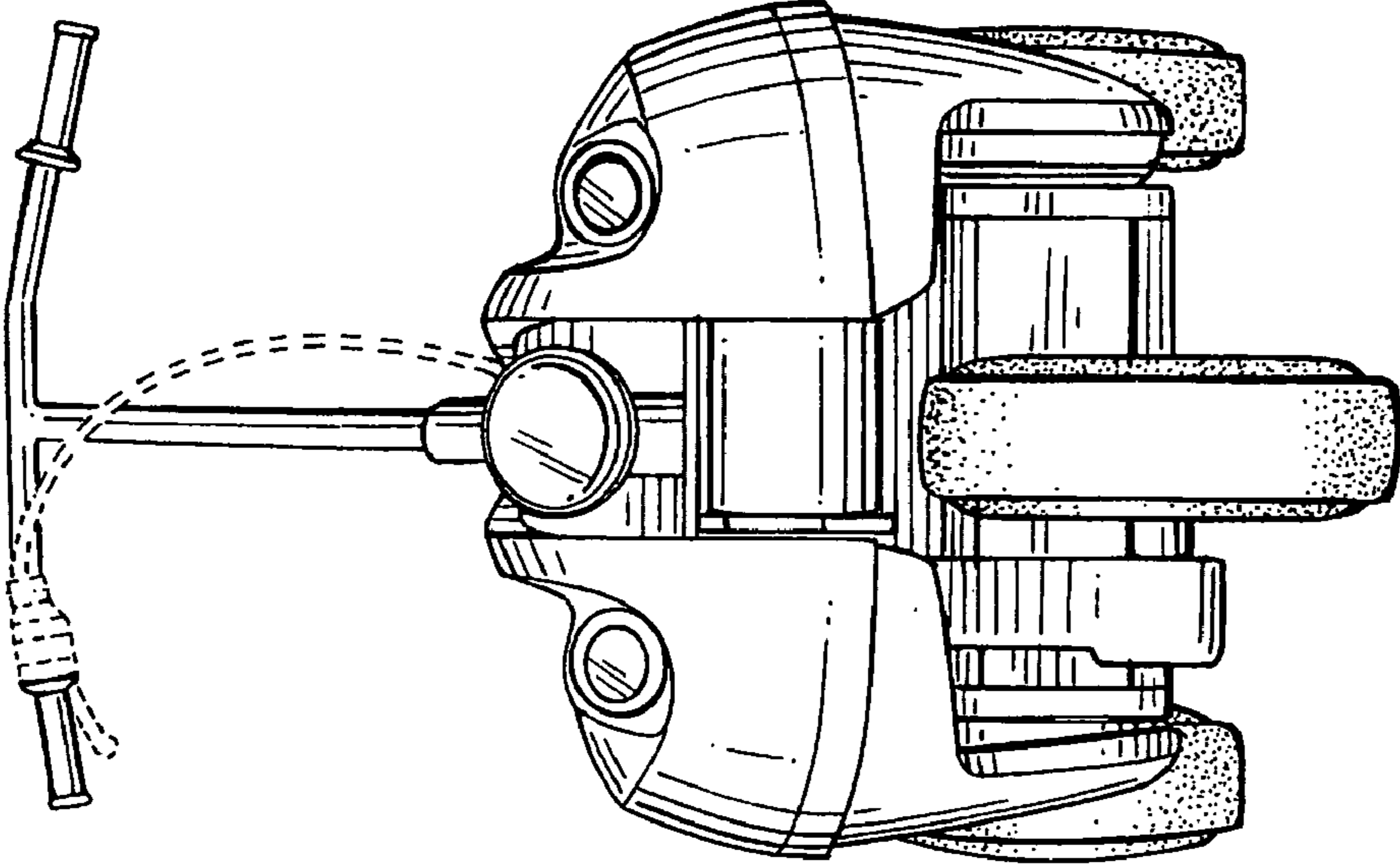




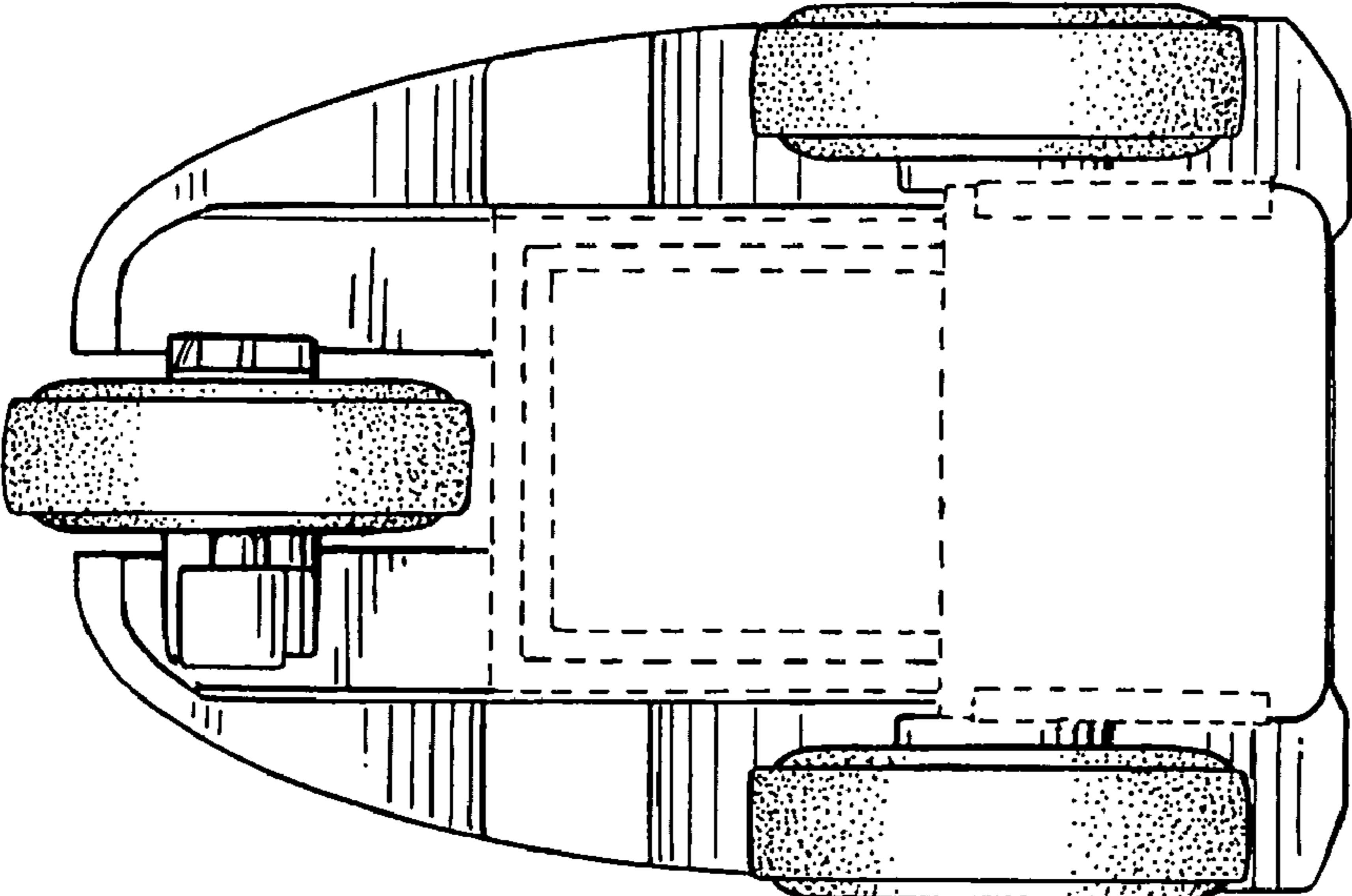
**FIG. 2**



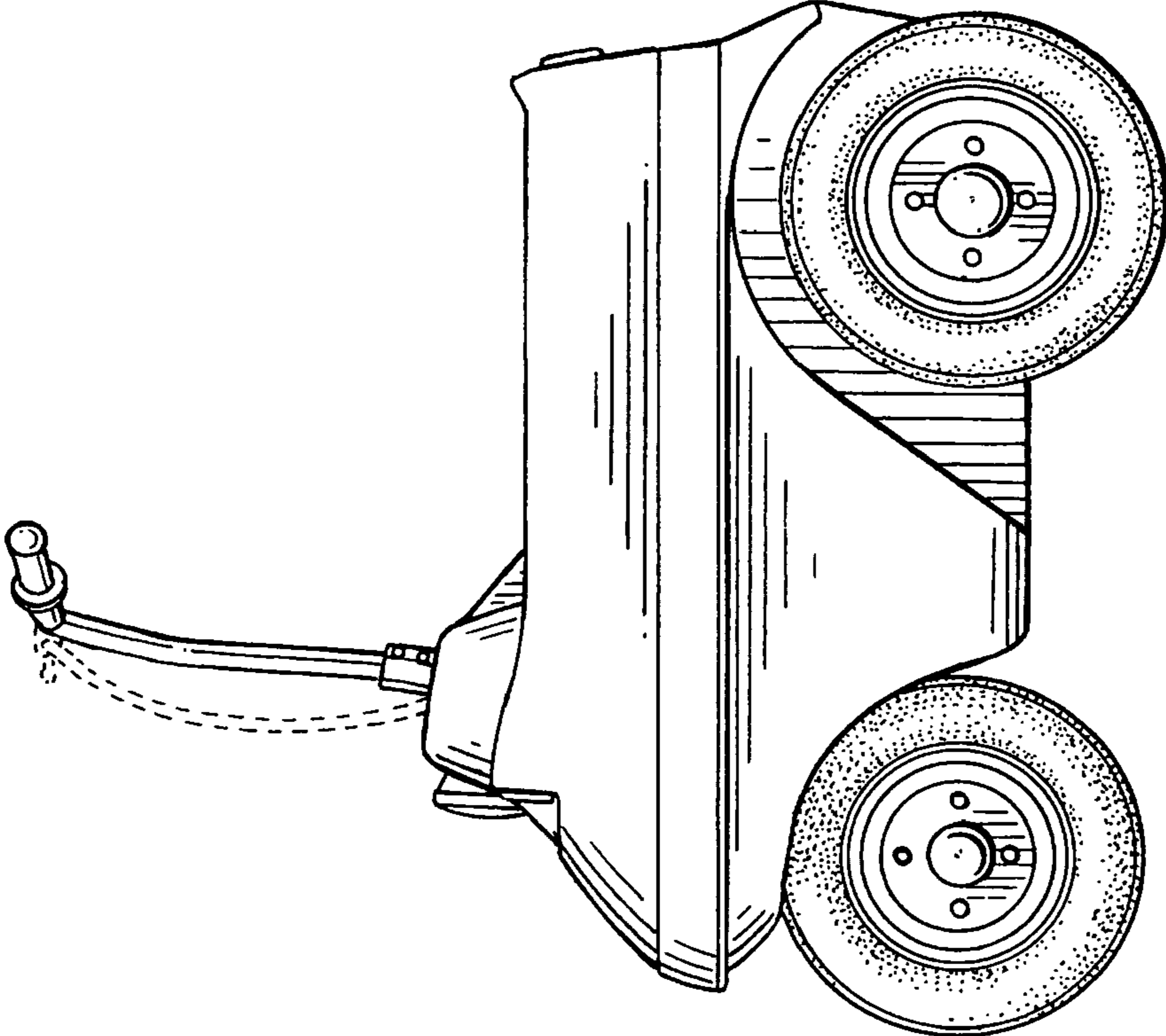
**FIG. 1**



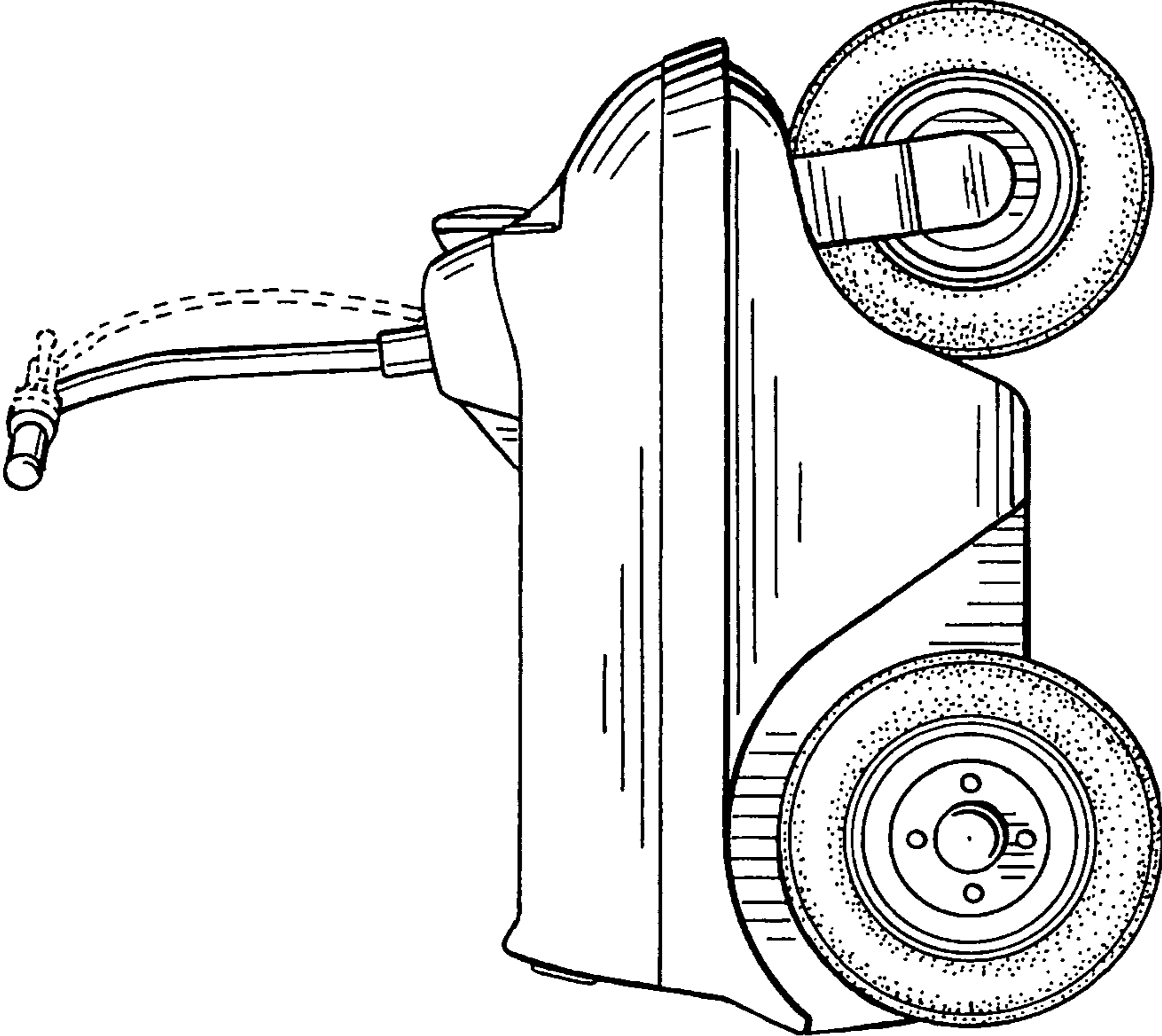
**FIG. 4**



**FIG. 3**



**FIG. 6**



**FIG. 5**