



US00D625660S

(12) **United States Design Patent**
Houston et al.

(10) **Patent No.:** **US D625,660 S**
(45) **Date of Patent:** **** Oct. 19, 2010**

(54) **PASSENGER VEHICLE**

(75) Inventors: **Steven W. Houston**, Evans, GA (US);
James Vincenzetti, Evans, GA (US);
Landon N. Ball, North Augusta, SC
(US); **James Consiglio**, Evans, GA (US)

(73) Assignee: **Textron Innovations Inc.**, Providence,
RI (US)

(**) Term: **14 Years**

(21) Appl. No.: **29/341,906**

(22) Filed: **Aug. 14, 2009**

(51) **LOC (9) Cl.** **12-02**

(52) **U.S. Cl.** **D12/16**

(58) **Field of Classification Search** D12/87,
D12/86, 1, 433, 15, 16, 107, 82, 88, 89, 90,
D12/91, 92, 93, 14; D15/30; D21/803; 180/233,
180/908; 280/DIG. 5, 183, 184, 185, 186,
280/28, 37.7

See application file for complete search history.

(56) **References Cited**

U.S. PATENT DOCUMENTS

5,588,690	A	12/1996	Showalter	
D439,549	S *	3/2001	Shambeau et al.	D12/14
D493,749	S *	8/2004	Duncan	D12/16
D498,436	S	11/2004	Bonner et al.	
D498,704	S *	11/2004	Bonner et al.	D12/16
6,883,846	B2 *	4/2005	Cheek et al.	296/1.02
D514,981	S	2/2006	Andrews et al.	
D520,937	S *	5/2006	Eisenhauer	D12/401
D533,326	S *	12/2006	Sugai	D34/15
D541,699	S *	5/2007	Andrews et al.	D12/16
D571,689	S	6/2008	Andrews et al.	

7,422,082	B2	9/2008	Reffitt	
D588,957	S	3/2009	Tuo	
D589,397	S	3/2009	Tuo	
2007/0216180	A1 *	9/2007	Hanson et al.	296/1.08
2007/0251751	A1	11/2007	Ball et al.	
2007/0256881	A1	11/2007	Ball et al.	
2007/0267237	A1 *	11/2007	Hanson et al.	180/89.1
2007/0267241	A1	11/2007	Ball	

FOREIGN PATENT DOCUMENTS

WO	WO-2004/067327	A2	8/2004
WO	WO-2004/067360	A1	8/2004

* cited by examiner

Primary Examiner—T. Chase Nelson
Assistant Examiner—Ania K Dworzecka

(74) *Attorney, Agent, or Firm*—Harness, Dickey & Pierce,
P.L.C.

(57) **CLAIM**

The ornamental design for a passenger vehicle, as shown and described.

DESCRIPTION

FIG. 1 is a perspective view of a passenger vehicle showing our new design;

FIG. 2 is a front elevation view thereof;

FIG. 3 is a left side elevation thereof;

FIG. 4 is a right side elevation thereof;

FIG. 5 is a top plan view thereof; and,

FIG. 6 is a rear elevation view thereof.

The broken line showings are for the purpose of illustrating the environment, and form no part of the claimed design.

1 Claim, 6 Drawing Sheets

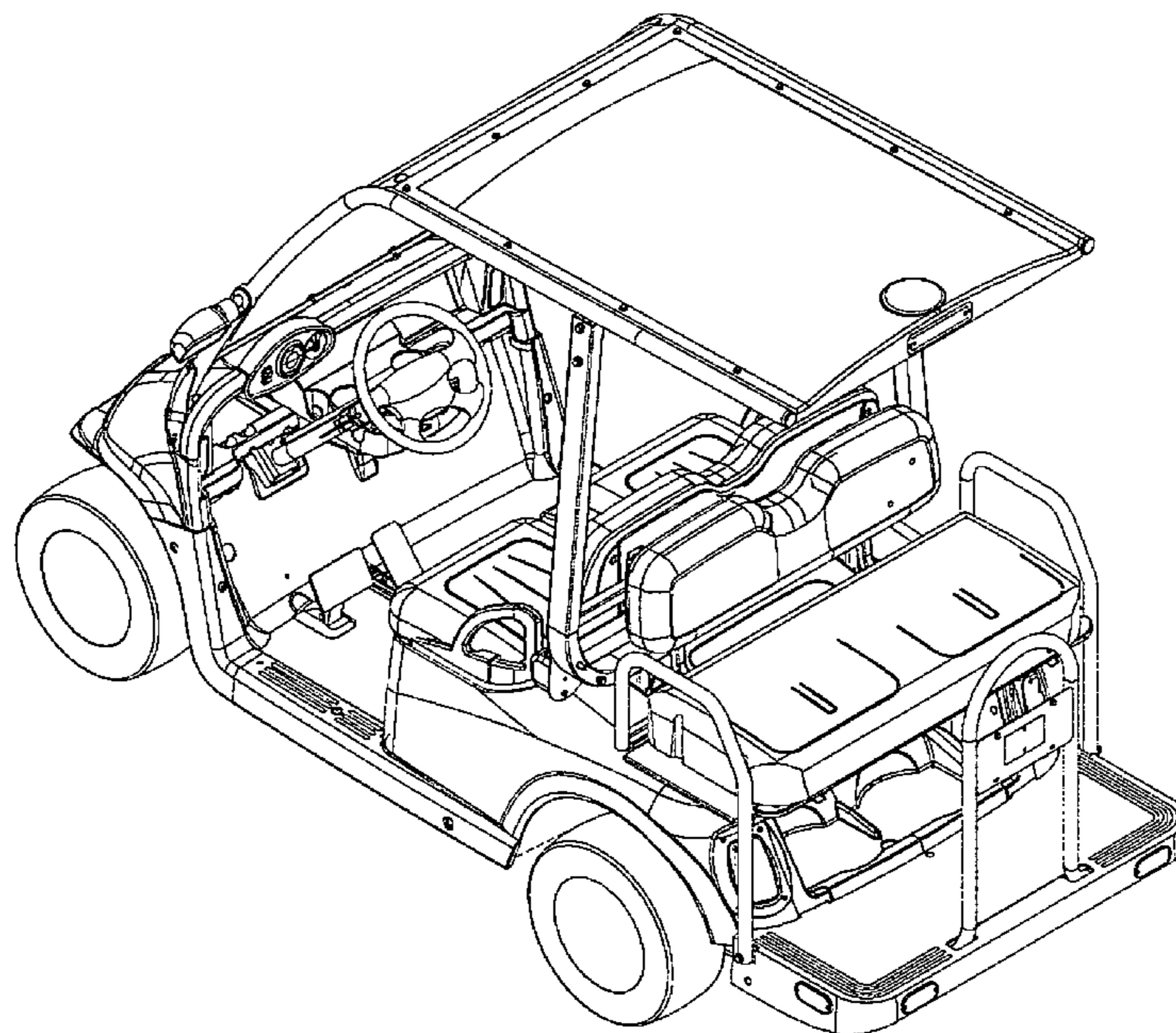

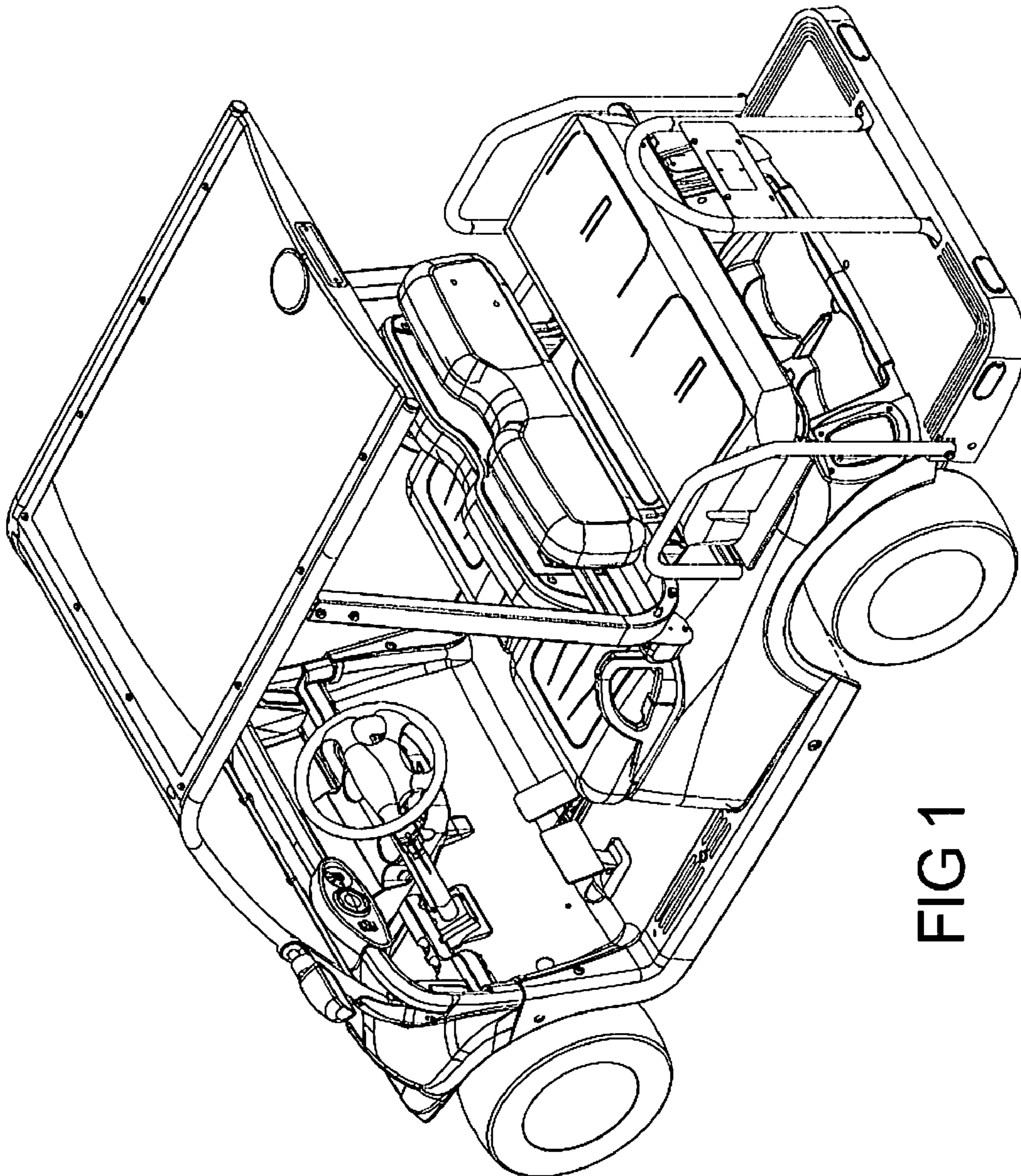

FIG 1

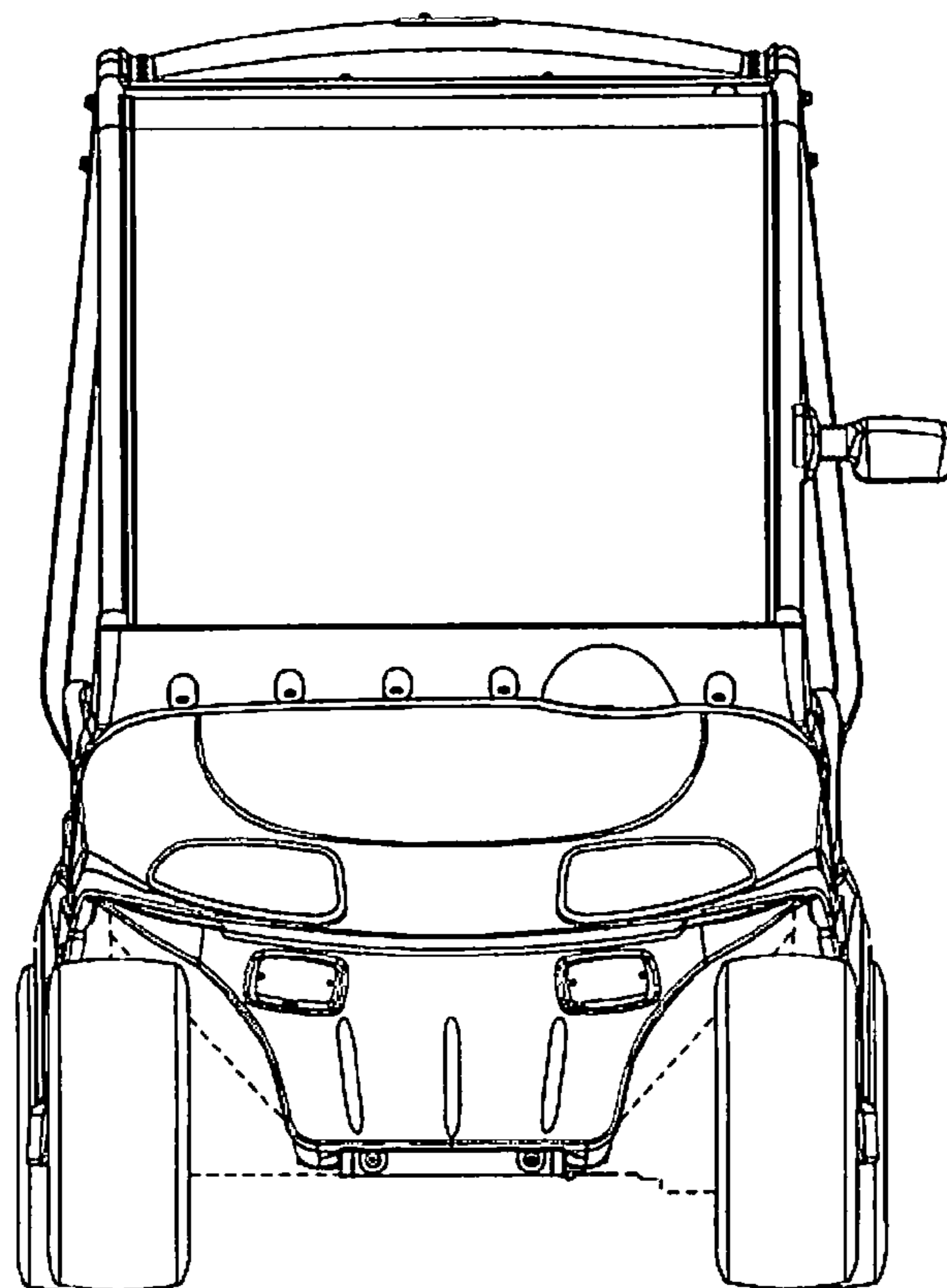

FIG 2

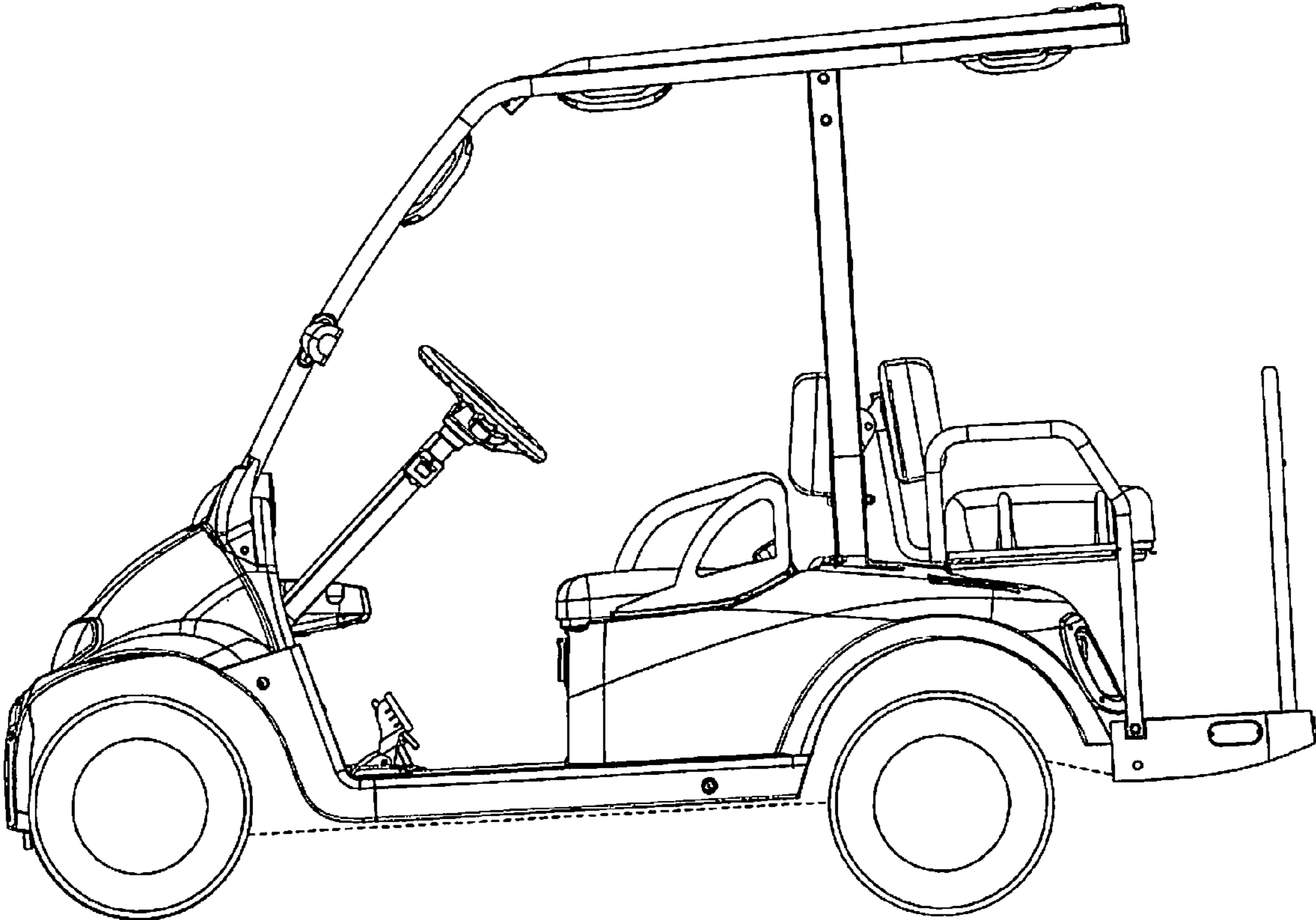

FIG 3

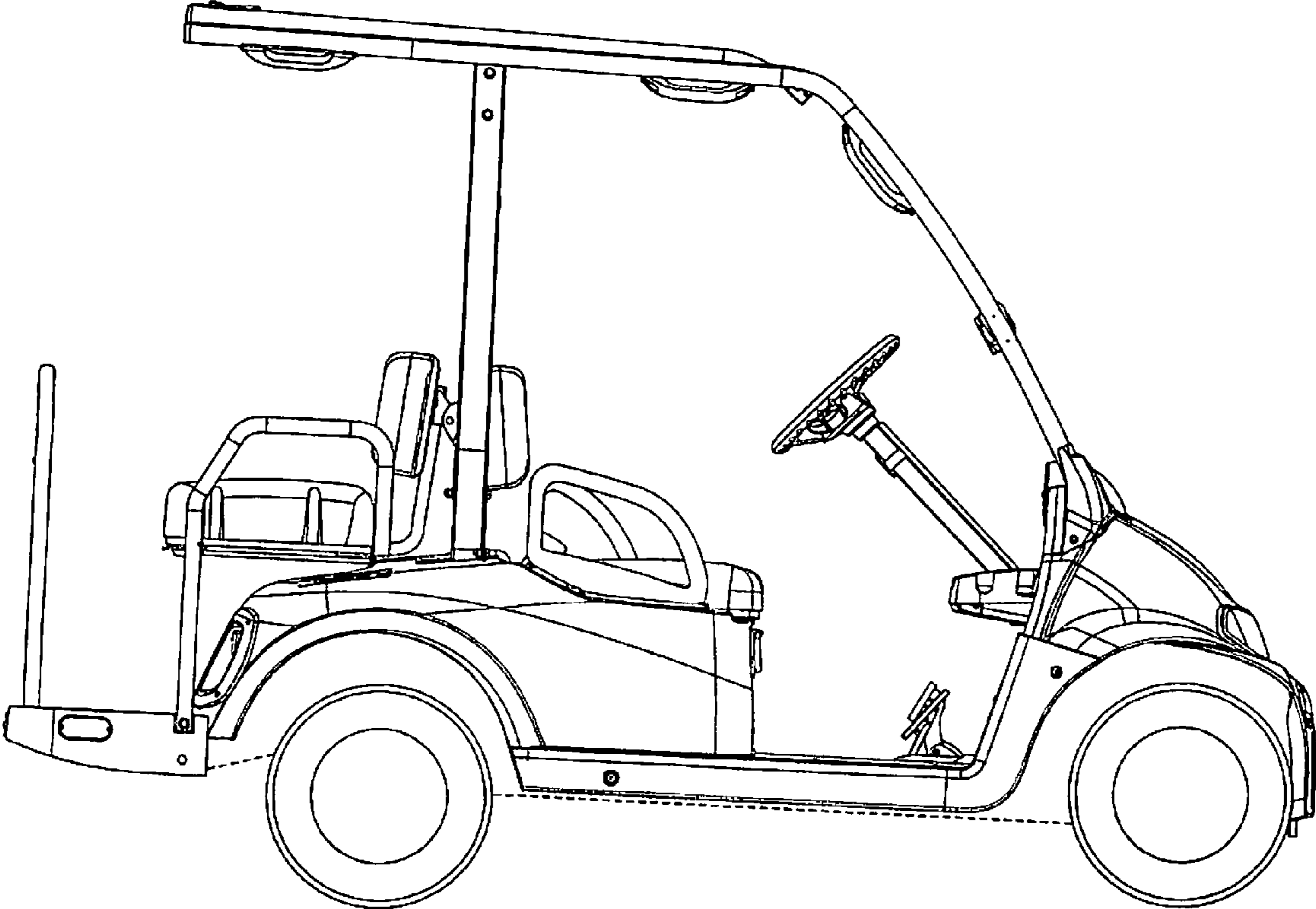

FIG 4

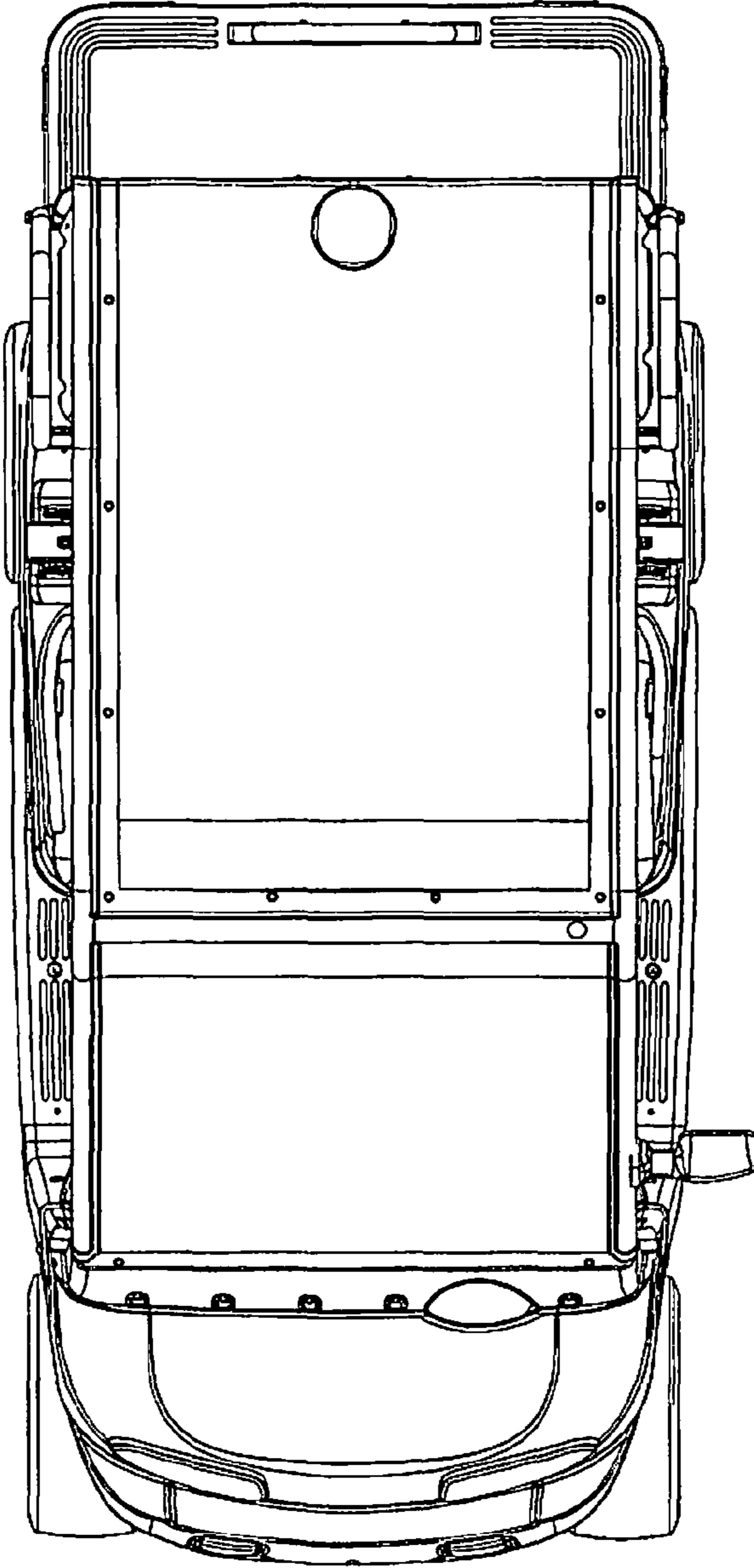

FIG 5

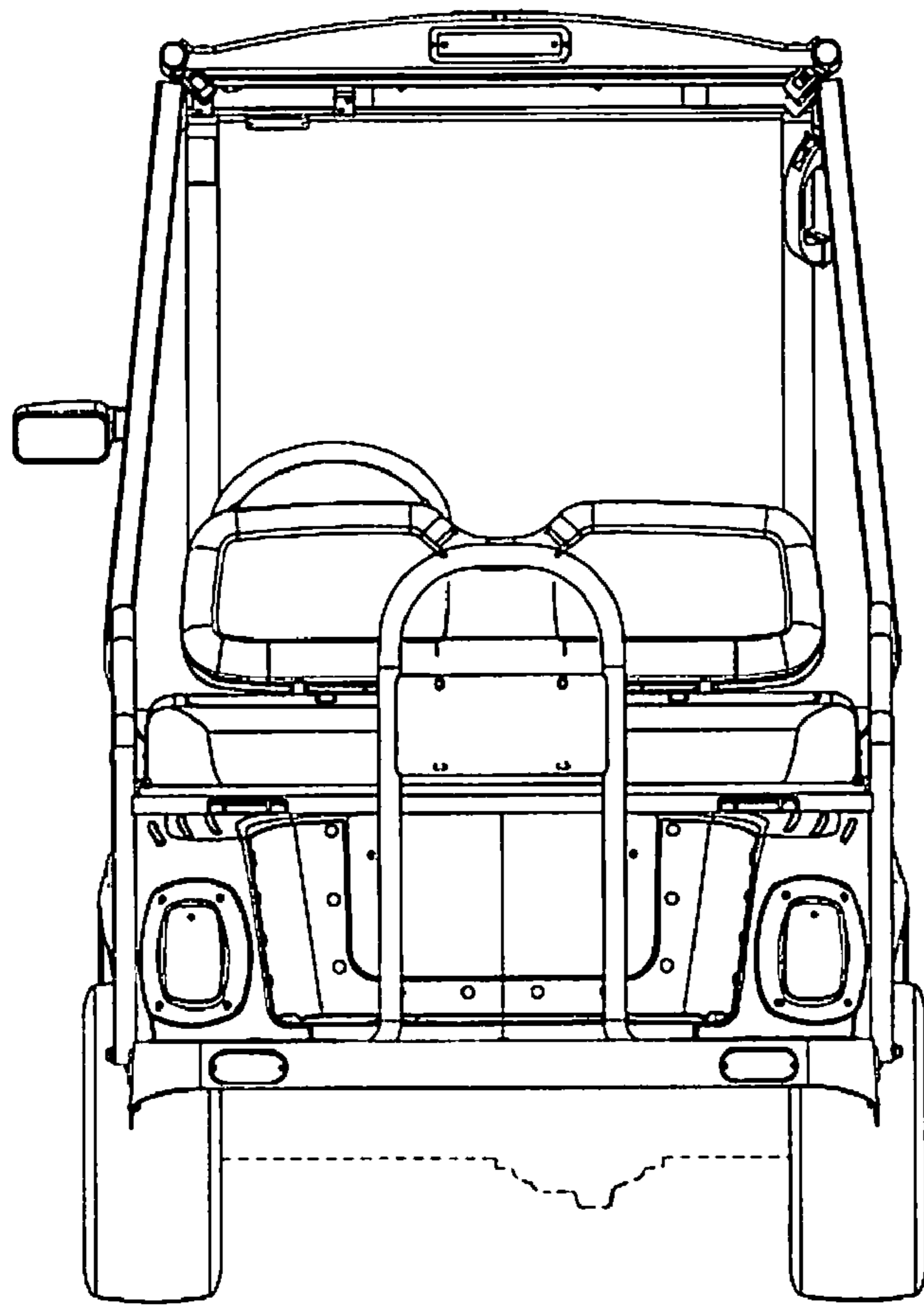

FIG 6