



US00D625625S

(12) **United States Design Patent**  
**Riddiford**

(10) **Patent No.:** **US D625,625 S**

(45) **Date of Patent:** **\*\* Oct. 19, 2010**

(54) **NAVIGATION DEVICE FOR USE ON A  
HANDGRIP OF A VEHICLE**

7,504,983 B2 \* 3/2009 Chen et al. .... 342/20  
2010/0078537 A1 \* 4/2010 Chen et al. .... 248/276.1

(75) Inventor: **Martin Riddiford**, London (GB)

(73) Assignee: **TomTom International B.V.**,  
Amsterdam (NL)

(\*\*) Term: **14 Years**

(21) Appl. No.: **29/344,724**

(22) Filed: **Oct. 2, 2009**

(51) **LOC (9) Cl.** ..... **10-04**

(52) **U.S. Cl.** ..... **D10/65; D10/98**

(58) **Field of Classification Search** ..... D10/65,  
D10/98; D14/341, 344, 507, 138 R, 138 AA,  
D14/203.3, 203.4, 203.5, 203.7; 342/386,  
342/351, 419, 457, 357.06–357.13, 20; 343/702,  
343/711, 712, 713, 714; 345/87, 104, 133,  
345/156, 168, 173, 901–905; 348/180, 184,  
348/315, 739; 364/444, 499; 701/206–209,  
701/213, 214; 248/276.1; 73/490, 493, 514.39,  
73/527; 235/95 R; 324/160–180, 207.13,  
324/207.22, 207.25; 340/432; 702/145–148  
See application file for complete search history.

(56) **References Cited**

**U.S. PATENT DOCUMENTS**

D276,707 S \* 12/1984 Segan et al. .... D10/98

\* cited by examiner

*Primary Examiner*—Antoine D Davis

(74) *Attorney, Agent, or Firm*—Harness, Dickey & Pierce,  
P.L.C.

(57) **CLAIM**

The ornamental design for a navigation device for use on a  
handgrip of a vehicle, as shown and described.

**DESCRIPTION**

FIG. 1 is a perspective view of a navigation device for use on  
a handgrip of a vehicle showing our new design;

FIG. 2 is a right side view thereof;

FIG. 3 is a left side view thereof;

FIG. 4 is a front view thereof;

FIG. 5 is a rear view thereof;

FIG. 6 is a top view thereof; and,

FIG. 7 is a bottom view thereof.

The broken lines shown in the drawings are for illustrative  
purposes only and from no part of the claimed design.

**1 Claim, 4 Drawing Sheets**

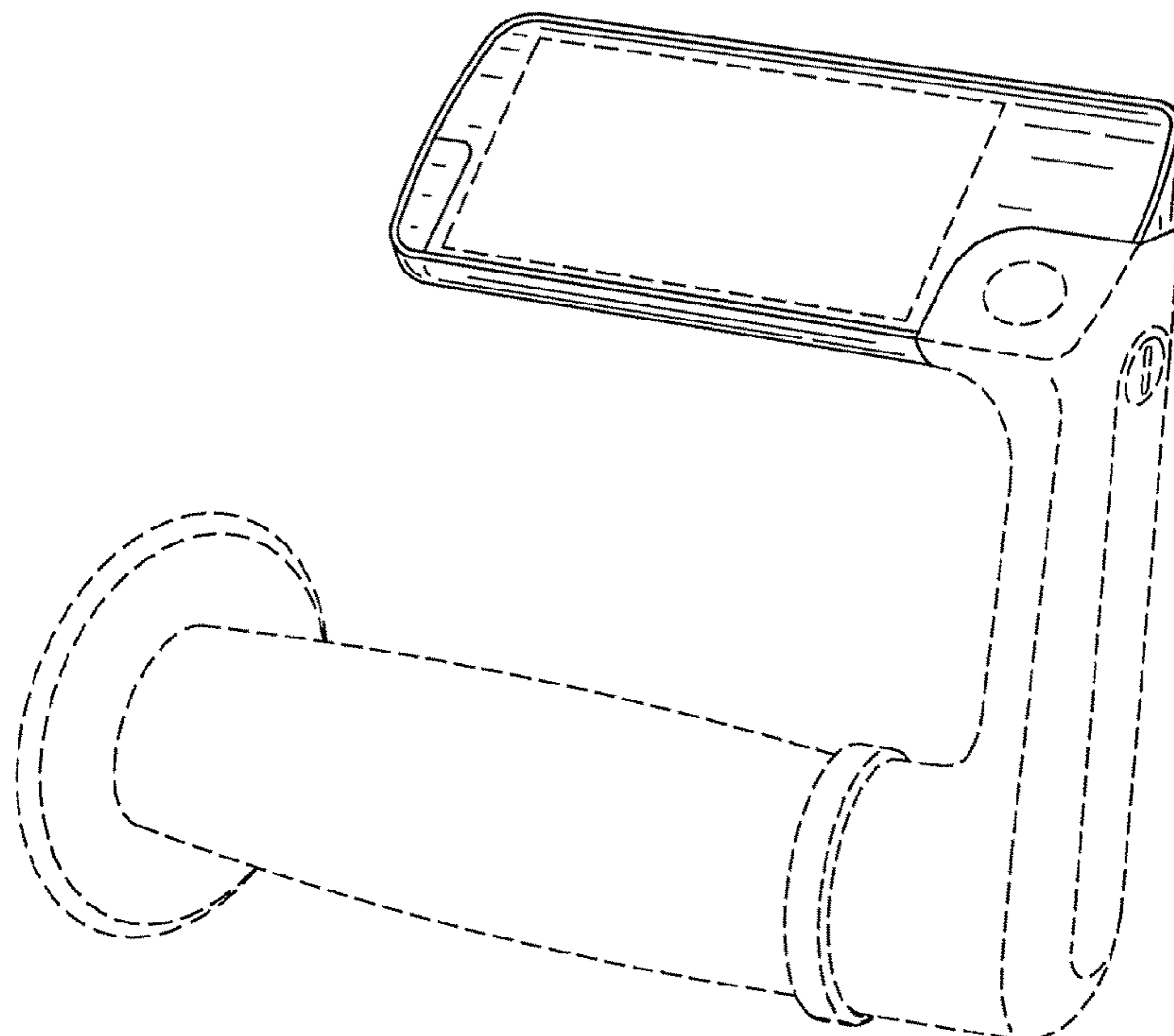

FIG. 1

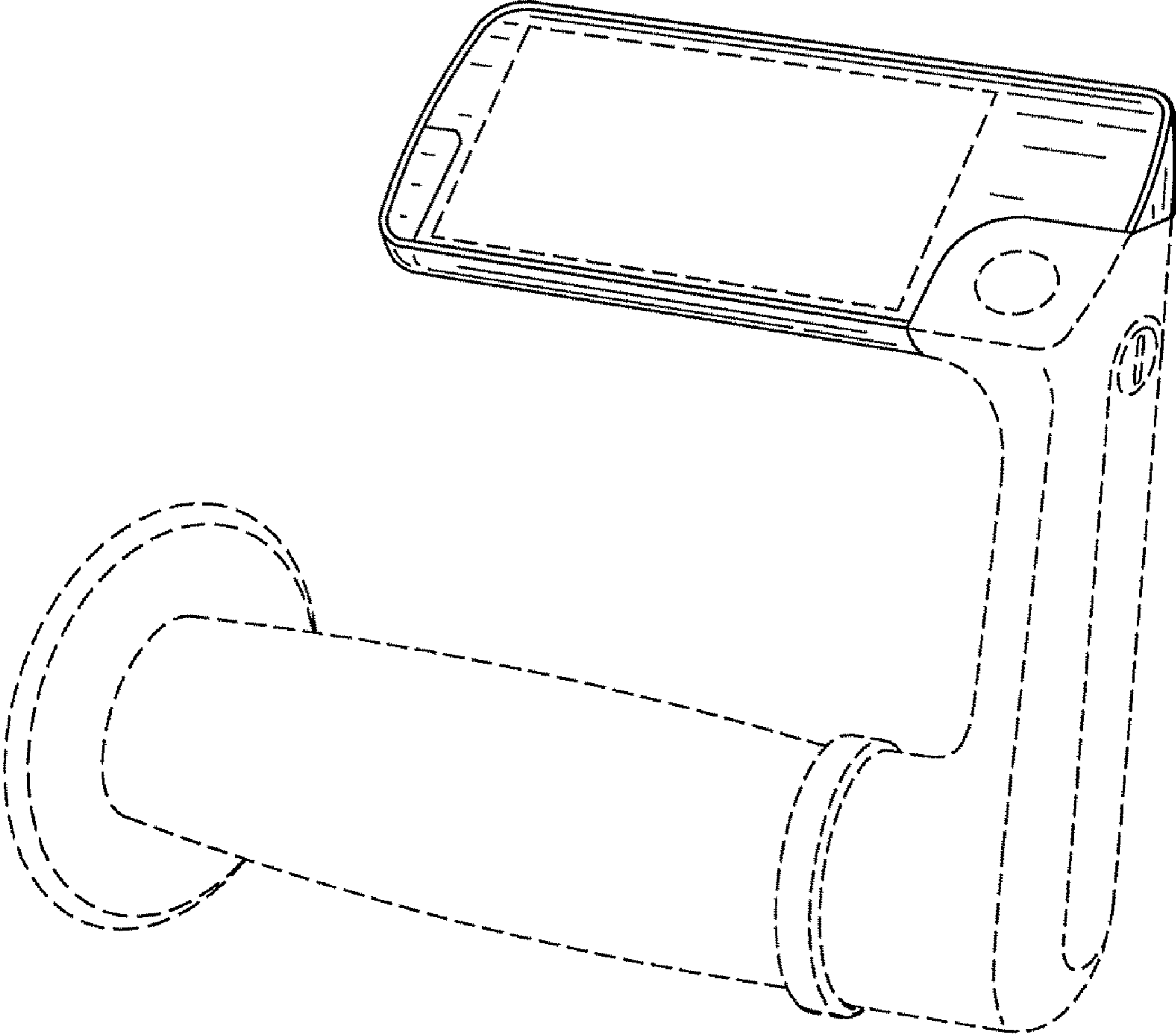

FIG. 2

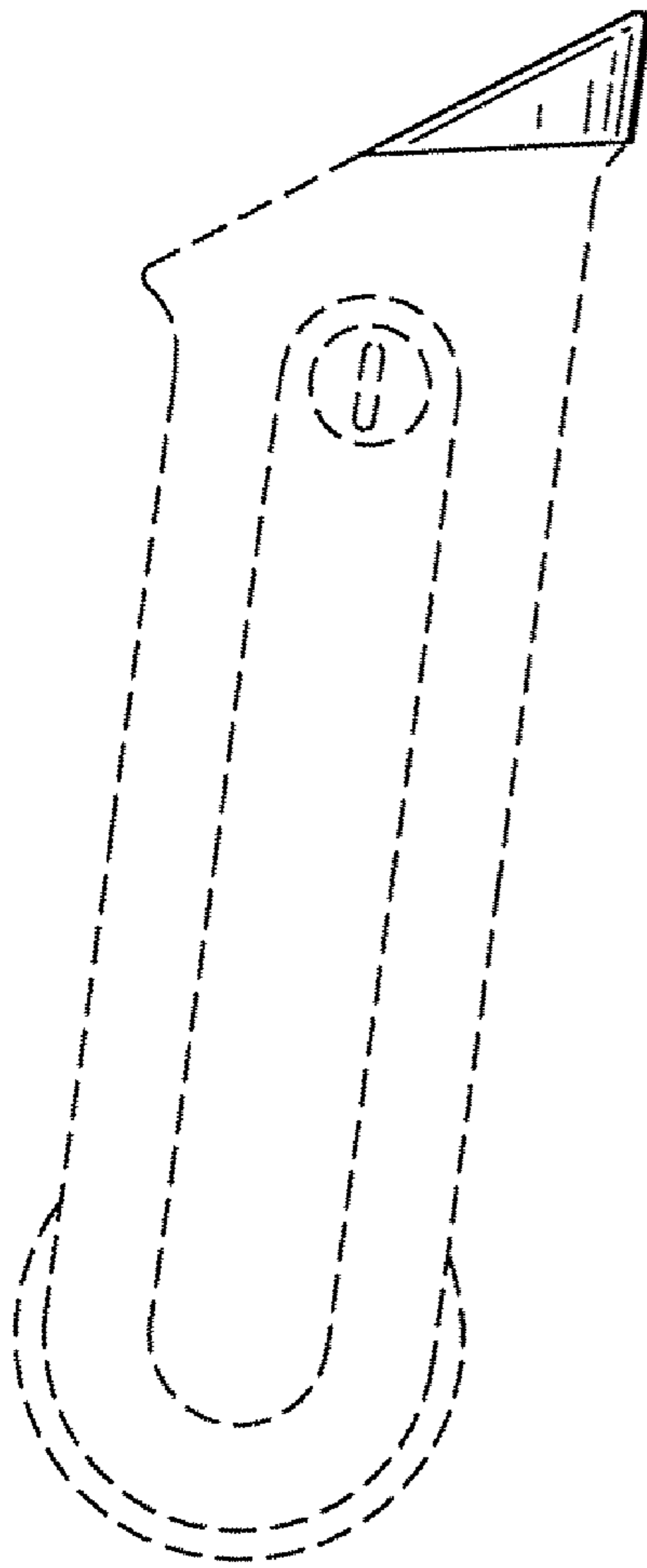

FIG. 3

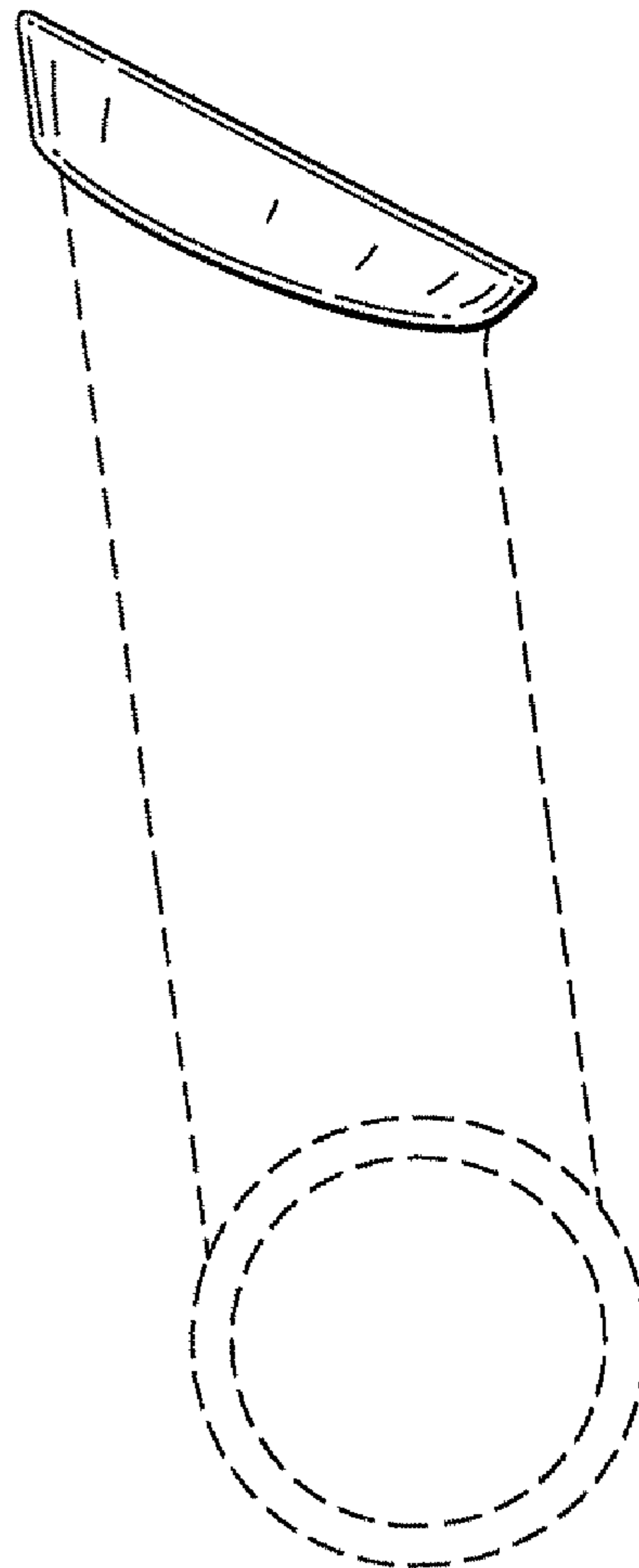

FIG. 4

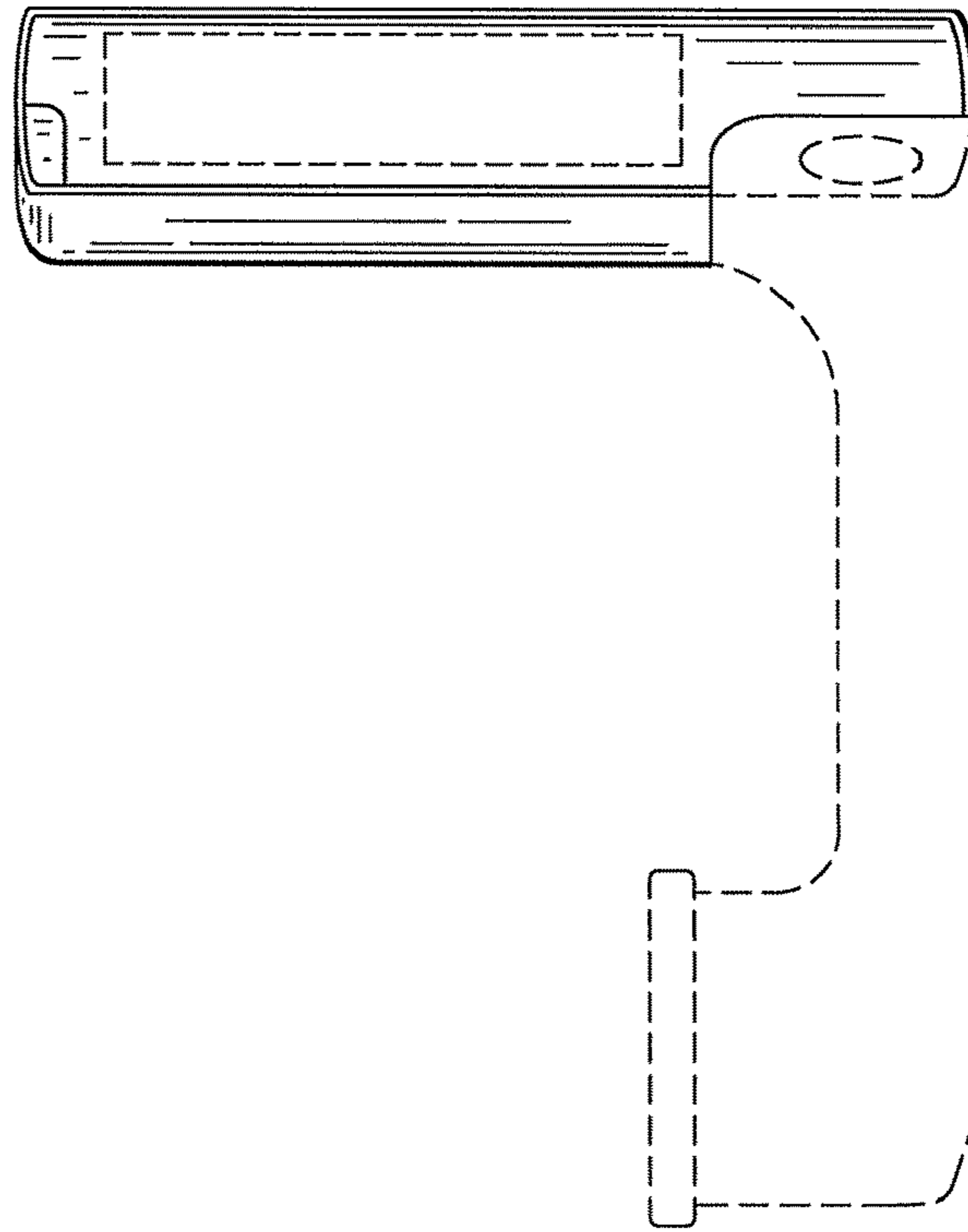

FIG. 5

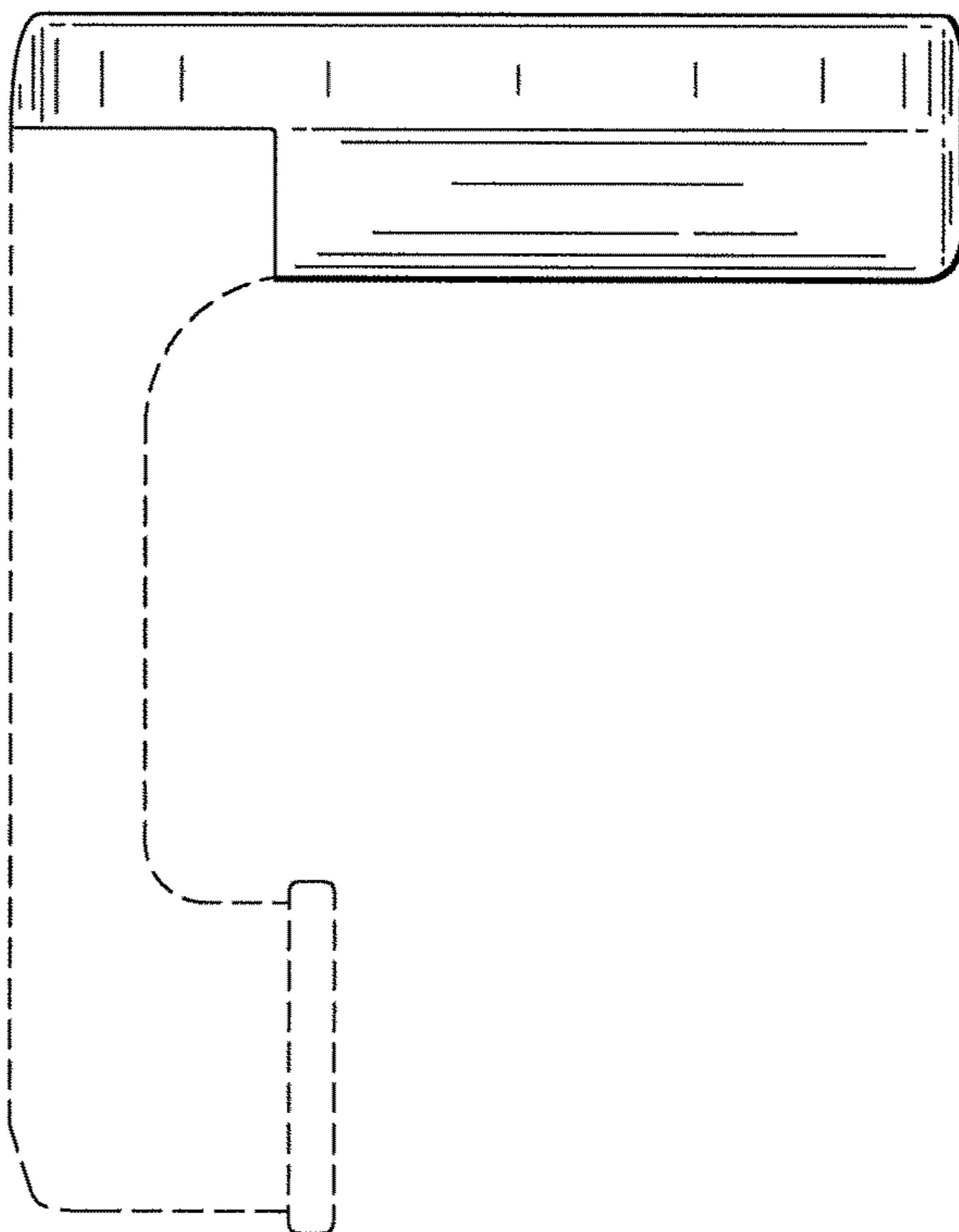

FIG. 6

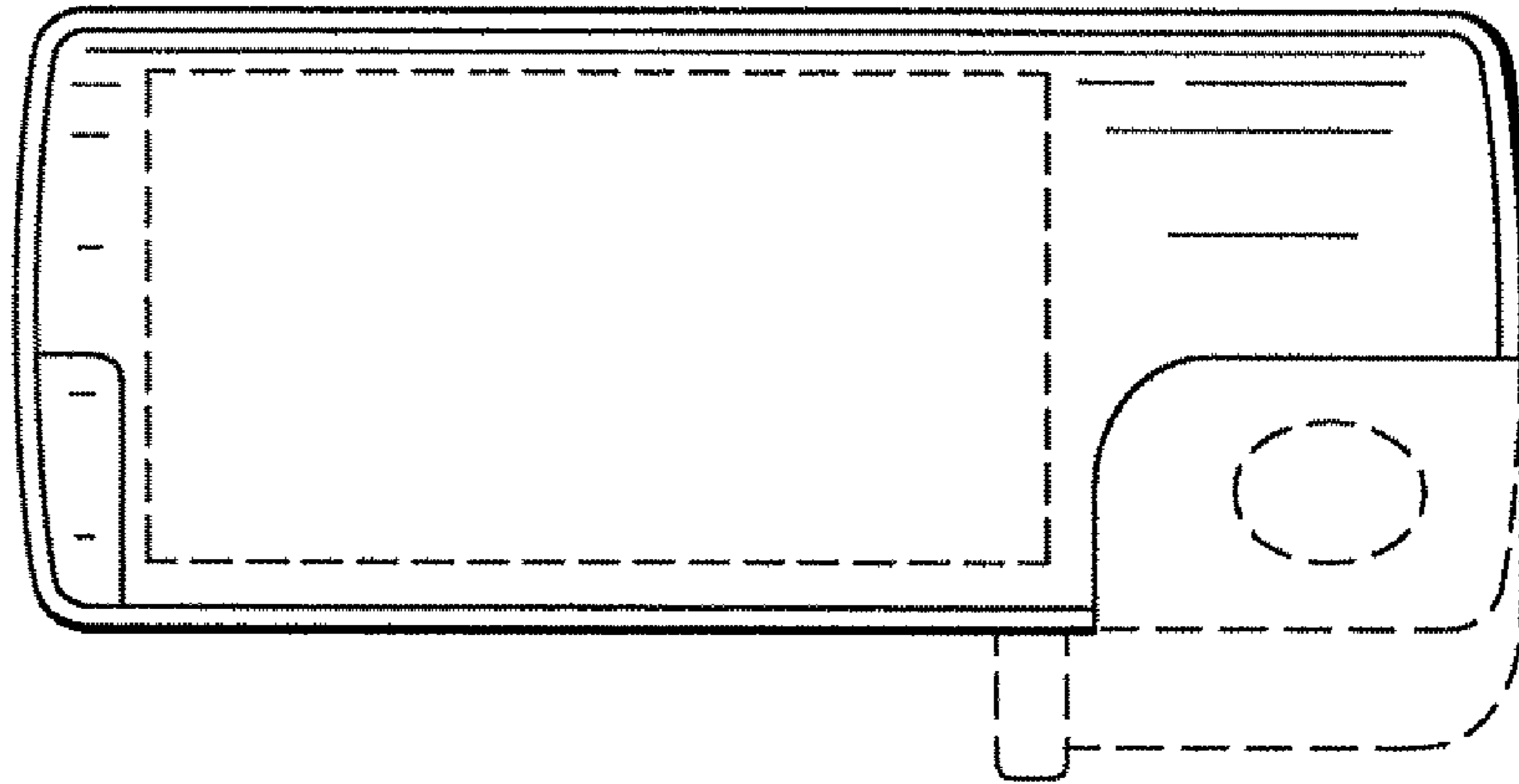

FIG. 7

