



US00D625198S

(12) **United States Design Patent**  
**Hall**

(10) **Patent No.:** **US D625,198 S**

(45) **Date of Patent:** **\*\* Oct. 12, 2010**

(54) **ANTI-BACTERIAL FOGGER**

(76) **Inventor:** **Jason David Hall**, 242 Rosewood Dr., Dalton, GA (US) 30721

(\*\*) **Term:** **14 Years**

(21) **Appl. No.:** **29/349,166**

(22) **Filed:** **Mar. 15, 2010**

(51) **LOC (9) Cl.** ..... **09-01**

(52) **U.S. Cl.** ..... **D9/691; D9/690**

(58) **Field of Classification Search** ..... D9/682-694, D9/516-575, 434-436, 447-450, 600-681, D9/763-783; D23/213-228; 222/129, 135, 222/153.01, 153.03, 153.04, 153.09, 153.11-153.14, 222/631, 635, 209, 211-213, 215, 321.7-321.9, 222/372, 373, 378, 379, 383.1, 384-386, 222/398, 400.7, 400.8, 401, 402.1-402.25

See application file for complete search history.

(56) **References Cited**

**U.S. PATENT DOCUMENTS**

- D93,940 S \* 11/1934 McManus ..... D9/500
- 2,116,077 A \* 5/1938 Mauguy et al. .... 222/212
- 2,959,325 A \* 11/1960 Beard, Jr. .... 222/1
- 3,107,826 A \* 10/1963 Kruck ..... 222/402.13
- D209,480 S \* 12/1967 Wallace ..... D9/772
- 3,853,248 A \* 12/1974 Williamson ..... 222/402.12
- D236,684 S \* 9/1975 Hebblethwaite ..... D9/690
- D240,112 S \* 6/1976 O'Neil ..... D9/692

- D241,816 S \* 10/1976 Kusakawa ..... D9/690
- D247,772 S \* 4/1978 Sexton, Jr. .... D9/772
- D273,563 S \* 4/1984 Jeans et al. .... D9/522
- D309,710 S \* 8/1990 Groves ..... D9/503
- D383,382 S \* 9/1997 Meshberg ..... D9/690
- 5,875,921 A \* 3/1999 Osgar et al. .... 222/1
- 6,264,120 B1 \* 7/2001 Wintering et al. .... 239/333
- D480,629 S \* 10/2003 Cabrera ..... D9/688

**FOREIGN PATENT DOCUMENTS**

GB 2021360 \* 3/1993

\* cited by examiner

*Primary Examiner*—Catherine Tuttle

(74) *Attorney, Agent, or Firm*—Richard L. Mikesell

(57) **CLAIM**

The ornamental design for an anti-bacterial fogger, as shown and described.

**DESCRIPTION**

FIG. 1: is a top right perspective view;

FIG. 2: is a top plan view;

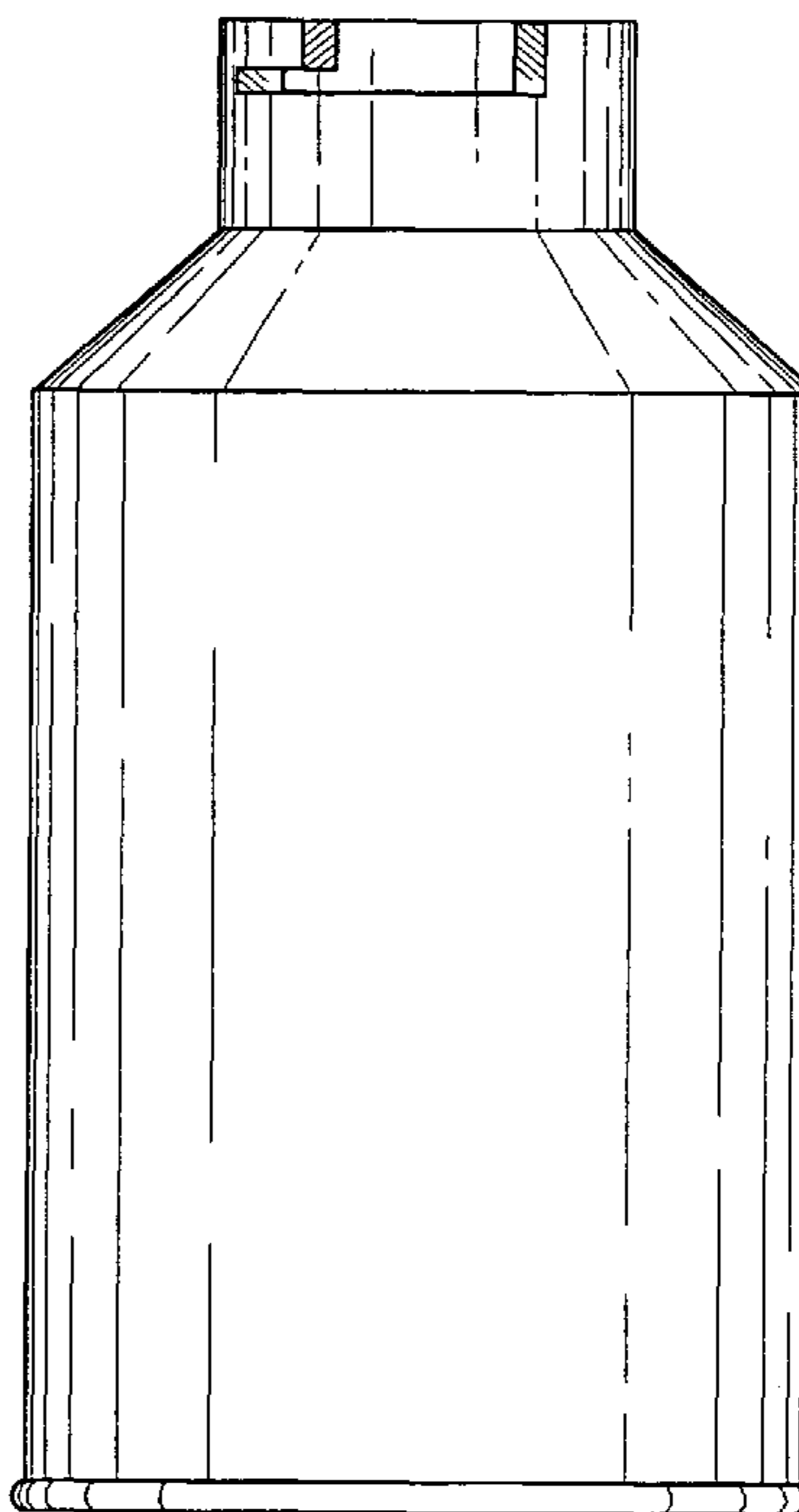
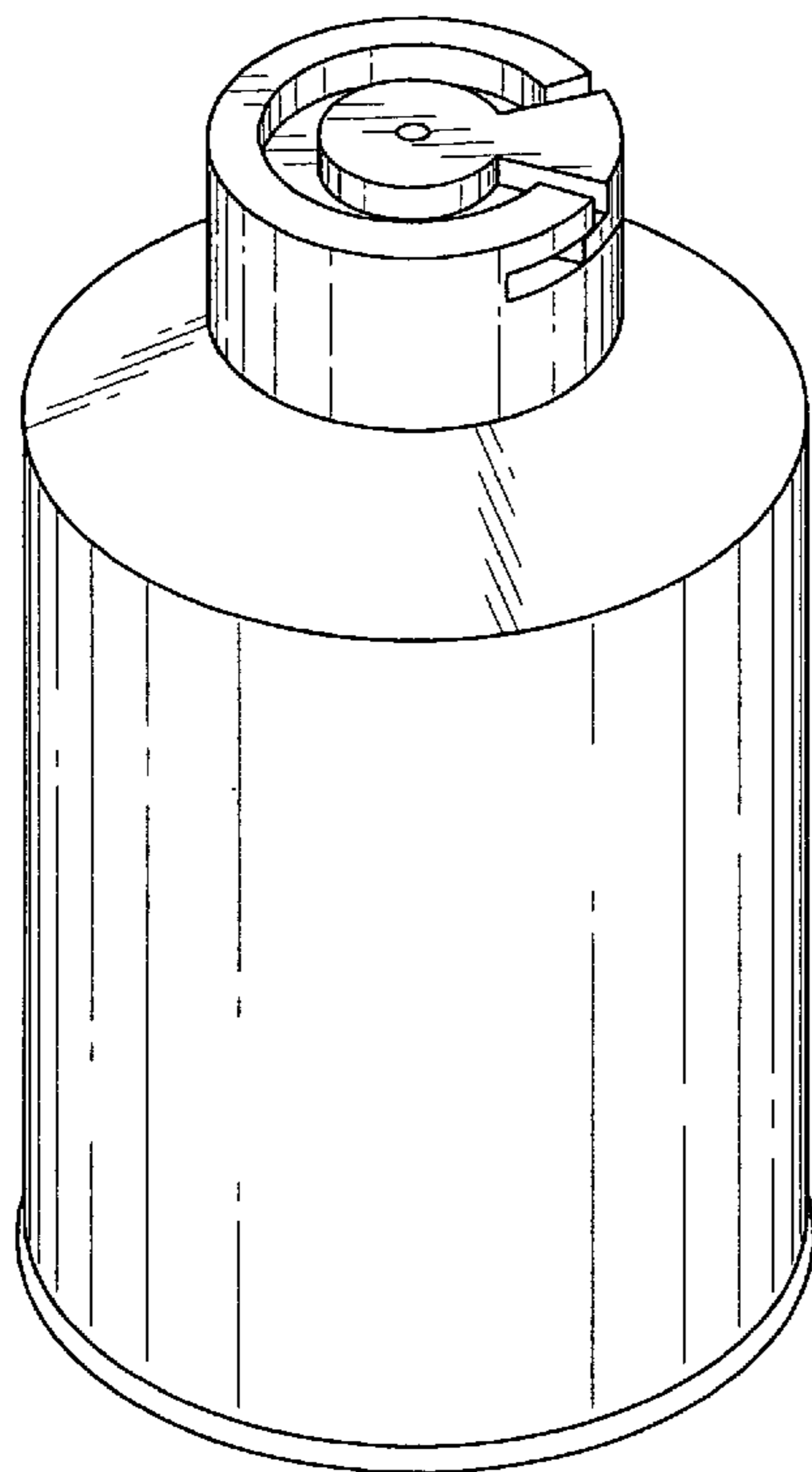
FIG. 3: is a bottom plan view;

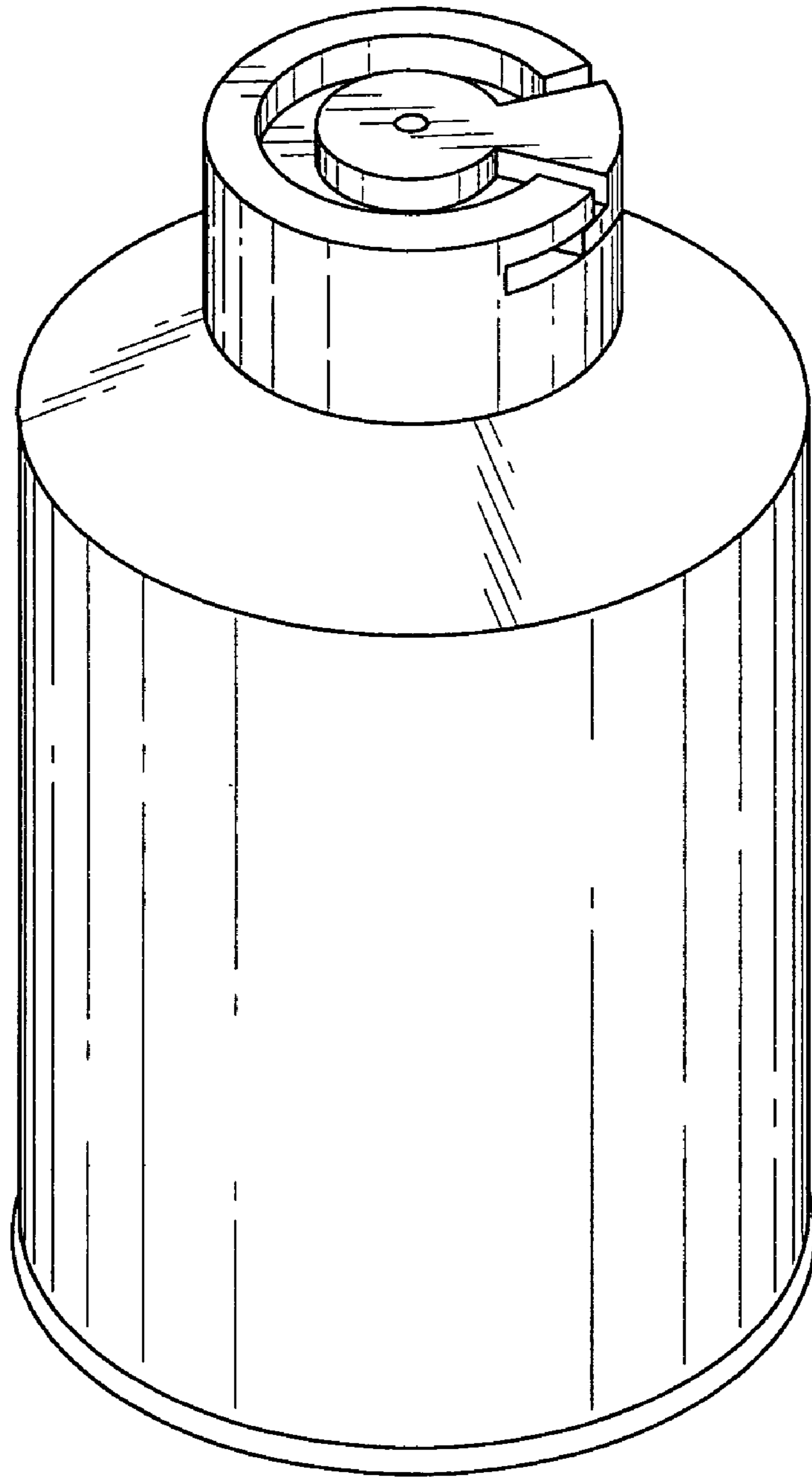
FIG. 4: is a front elevation; and,

FIG. 5: is a right side elevation.

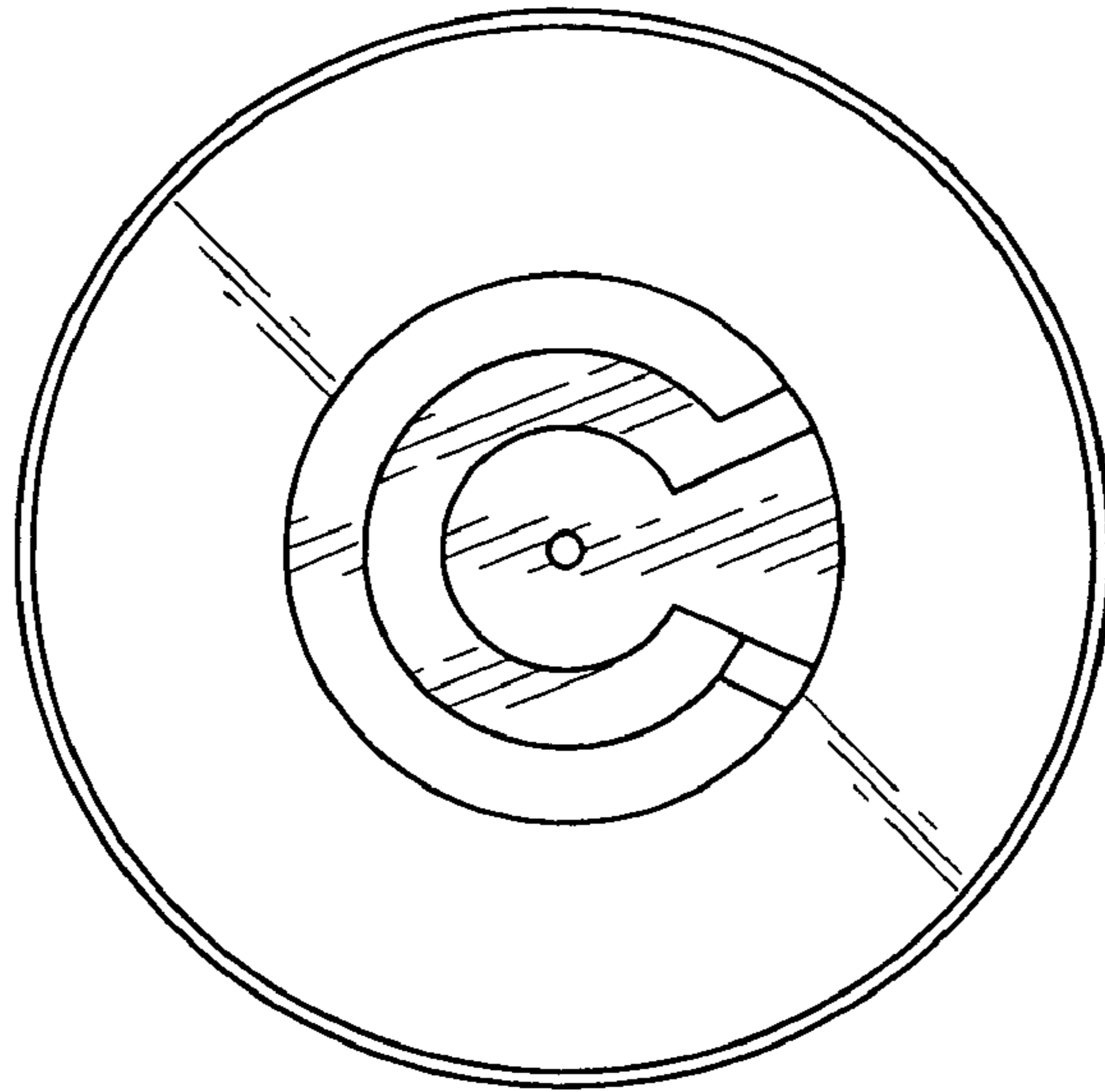
The surfaces opposite to the view shown in FIG. 1 continue the configuration and surface appearance of the portions shown.

**1 Claim, 4 Drawing Sheets**

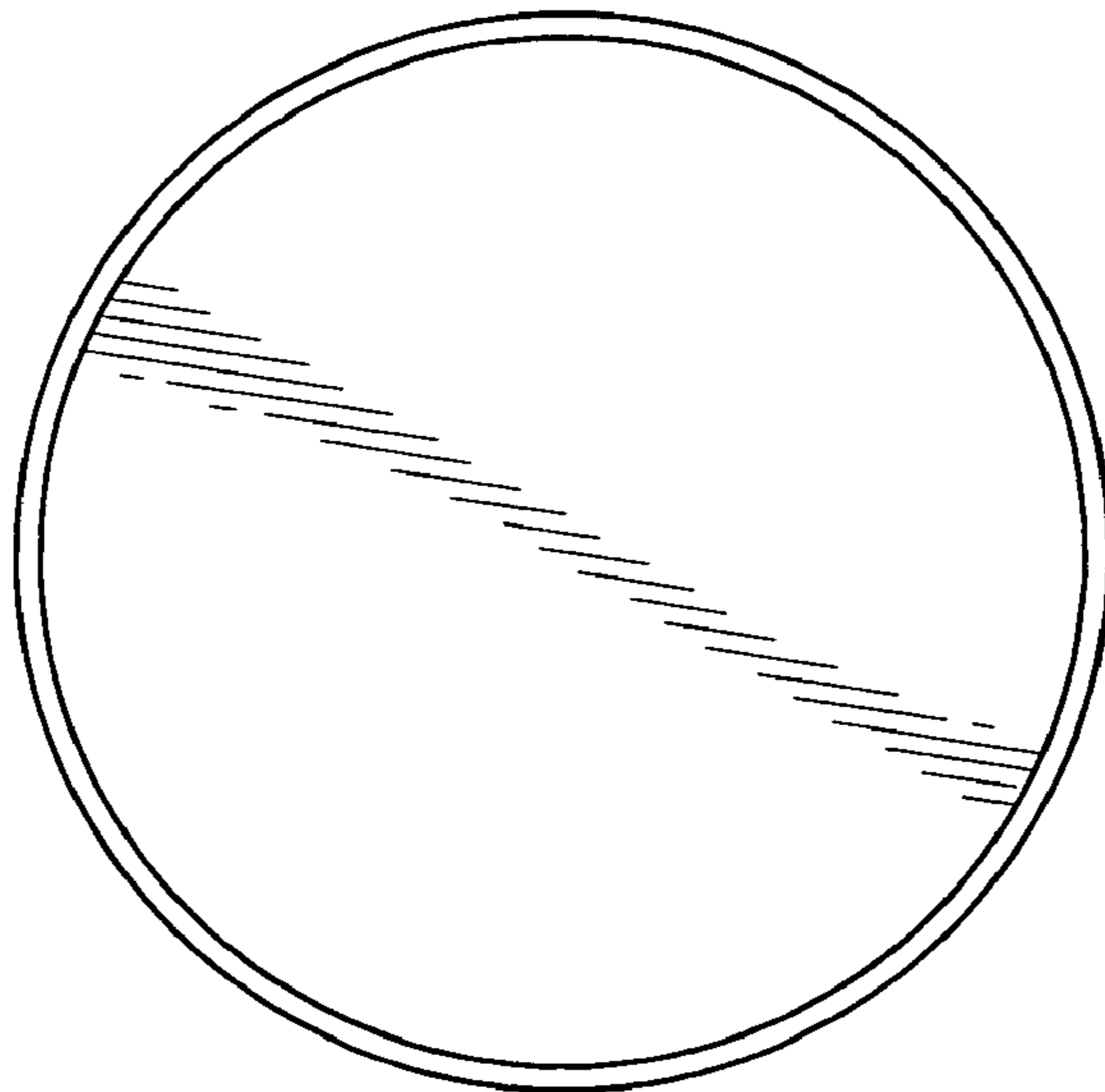




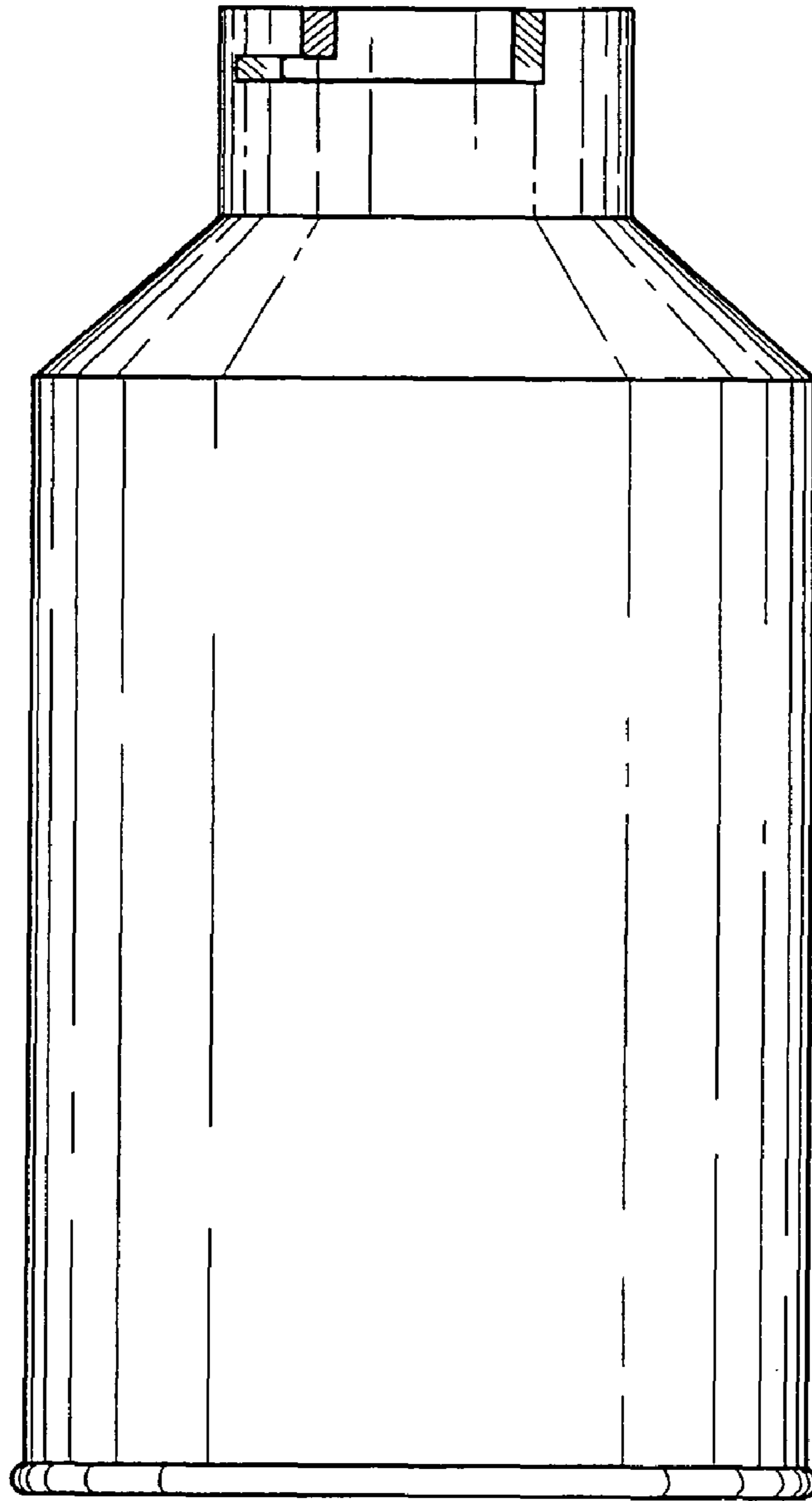
**Fig. 1**



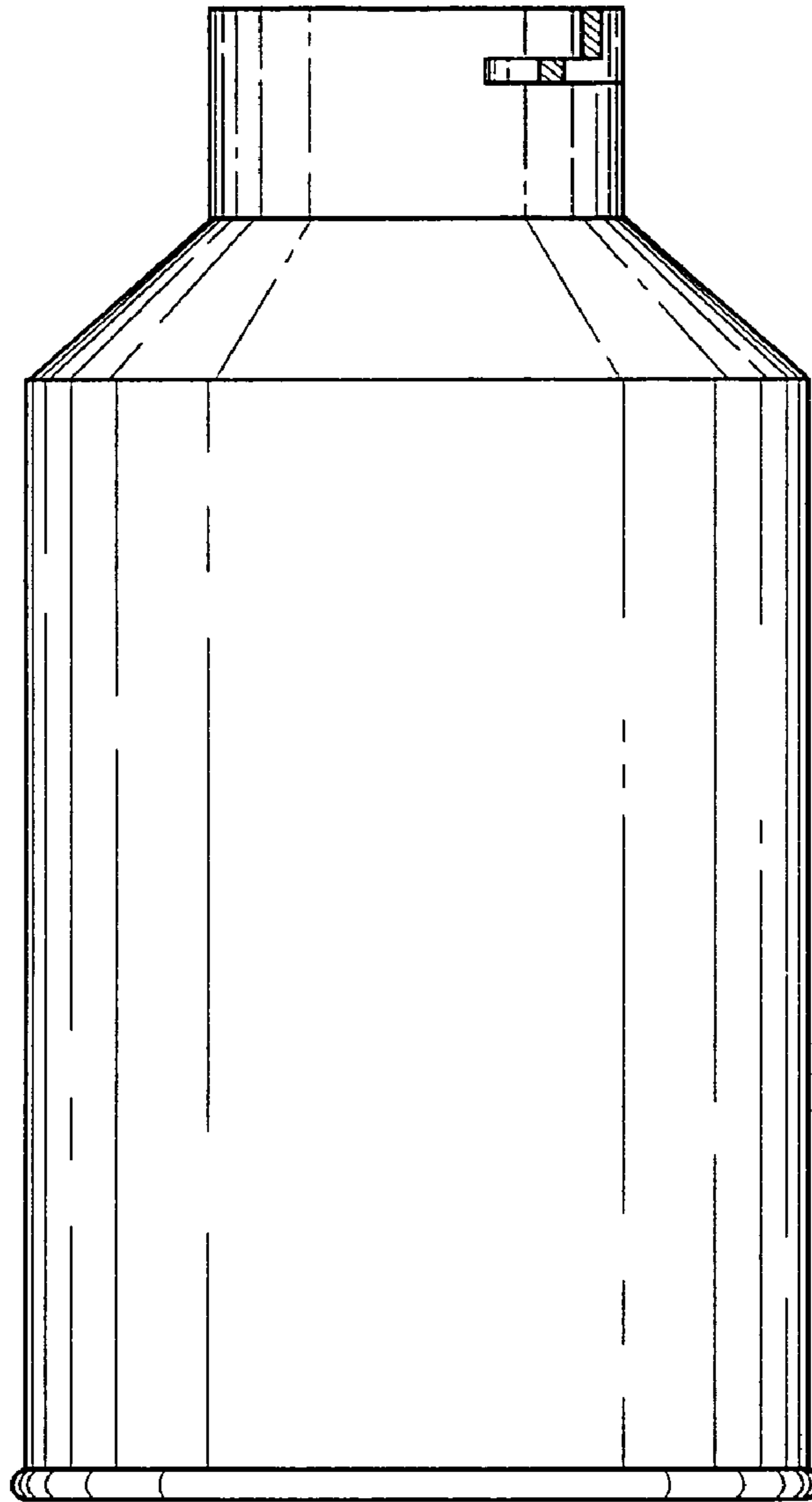
**Fig. 2**



**Fig. 3**



**Fig. 4**



***Fig. 5***