



US00D625171S

(12) **United States Design Patent**  
**Kiely**

(10) **Patent No.:** **US D625,171 S**

(45) **Date of Patent:** **\*\* Oct. 12, 2010**

(54) **SUPPORT CLAMP**

(75) **Inventor:** **Kenneth M. Kiely**, Milford, CT (US)

(73) **Assignee:** **Bridgeport Fittings, Inc.**, Stratford, CT (US)

(\*\*) **Term:** **14 Years**

(21) **Appl. No.:** **29/348,194**

(22) **Filed:** **Dec. 8, 2009**

(51) **LOC (9) Cl.** ..... **08-05**

(52) **U.S. Cl.** ..... **D8/356**

(58) **Field of Classification Search** ..... D8/105,  
D8/107, 333, 349, 354, 356, 358, 360, 360.1,  
D8/367, 372, 373, 382, 383, 394-396, 400;  
D13/133, 139.4, 153, 155; 24/18, 20 W,  
24/23 W, 115 R, 129 C, 130, 131 R, 197,  
24/561; 52/220.7; 174/135, 153 G, 650,  
174/656; 211/86.01, 87.01, 94.01; 242/400.1,  
242/405.1, 405.2, 600, 603; 248/65, 74.1-74.4,  
248/201, 214, 215, 229.26

See application file for complete search history.

(56) **References Cited**

**U.S. PATENT DOCUMENTS**

2,267,449 A \* 12/1941 Eby ..... 439/411  
3,350,862 A \* 11/1967 Nutting ..... 55/493  
4,247,163 A \* 1/1981 Lumpp et al. .... 385/136  
D365,510 S \* 12/1995 Kiely et al. .... D8/373  
5,872,335 A \* 2/1999 Mullen, Jr. .... 174/653  
D409,082 S \* 5/1999 Donahue ..... D8/373  
D458,592 S \* 6/2002 Gust et al. .... D13/155

D470,461 S \* 2/2003 Liang ..... D13/151  
D554,237 S \* 10/2007 Lewis et al. .... D23/259  
7,394,021 B2 \* 7/2008 Magno, Jr. .... 174/59  
D604,242 S \* 11/2009 Kiely ..... D13/133  
2009/0025977 A1 \* 1/2009 Anderson et al. .... 174/653  
2009/0242270 A1 \* 10/2009 Rumsey ..... 174/650

\* cited by examiner

*Primary Examiner*—Robert M Spear

*Assistant Examiner*—Karen Acker

(74) *Attorney, Agent, or Firm*—Alfred A. Fressola; Ware, Fressola, Van Der Sluys & Adolphson LLP

(57) **CLAIM**

The ornamental design for a support clamp, as shown and described.

**DESCRIPTION**

FIG. 1 is a perspective view of the support clamp of my design;

FIG. 2 is a further perspective view thereof looking from the side of FIG. 1;

FIG. 3 is a front elevational view thereof;

FIG. 4 is a side elevational view thereof, the opposite side being a mirror image thereof;

FIG. 5 is a rear elevational view thereof;

FIG. 6 is a top plan view thereof; and,

FIG. 7 is a bottom plan view thereof.

The broken lines in the drawings represent unclaimed environmental subject matter.

**1 Claim, 2 Drawing Sheets**

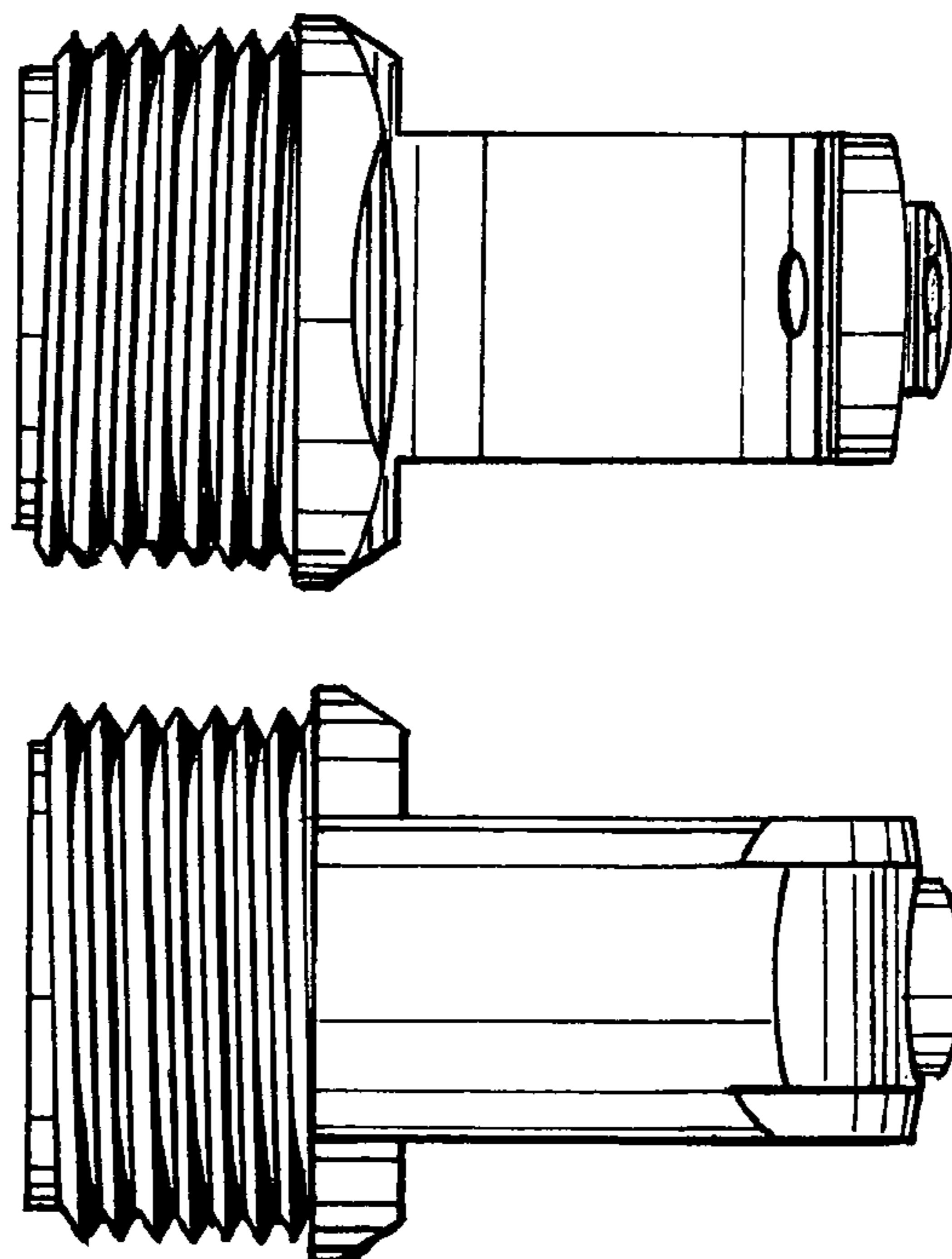

**FIG. 1**

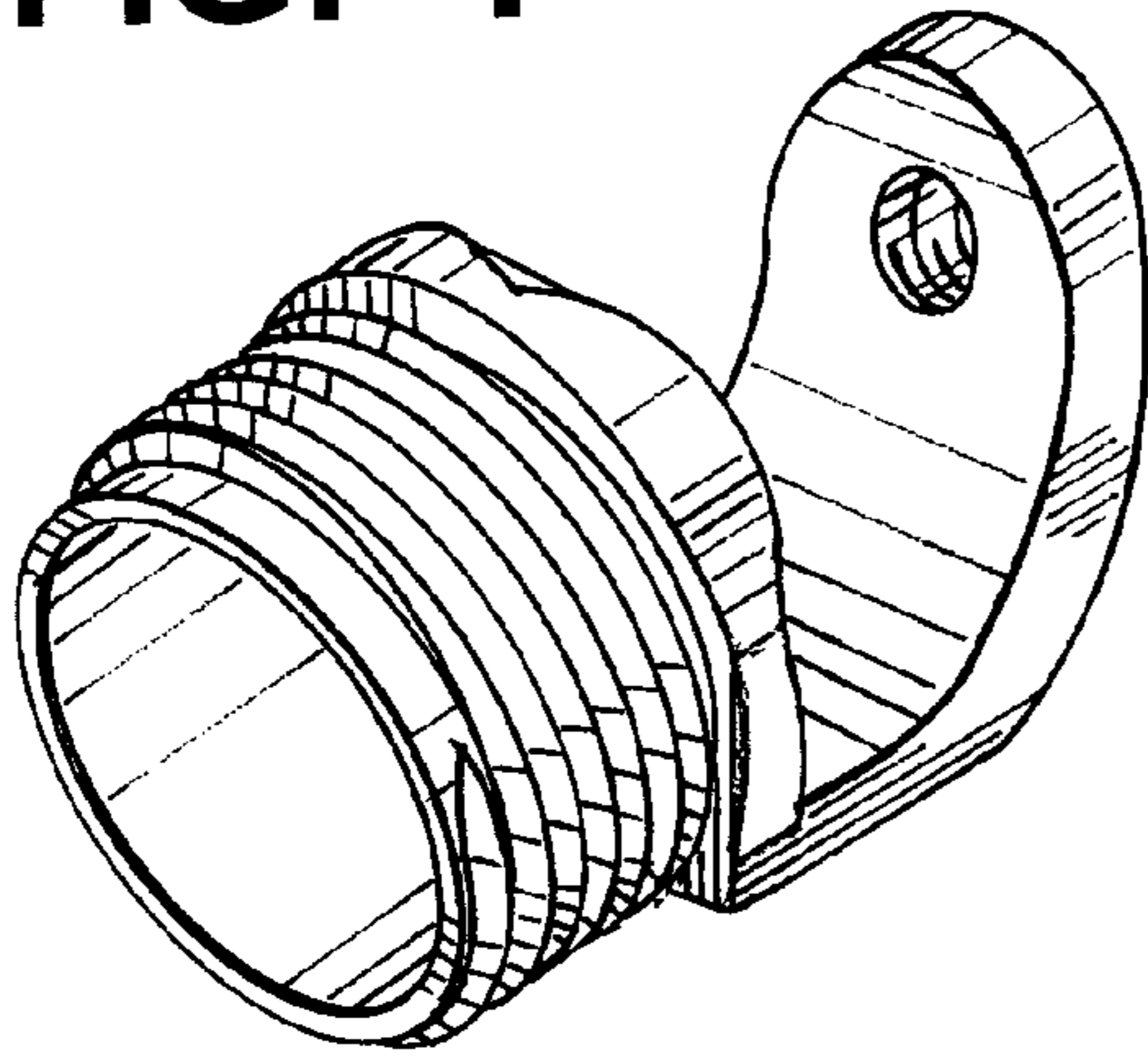

**FIG. 2**

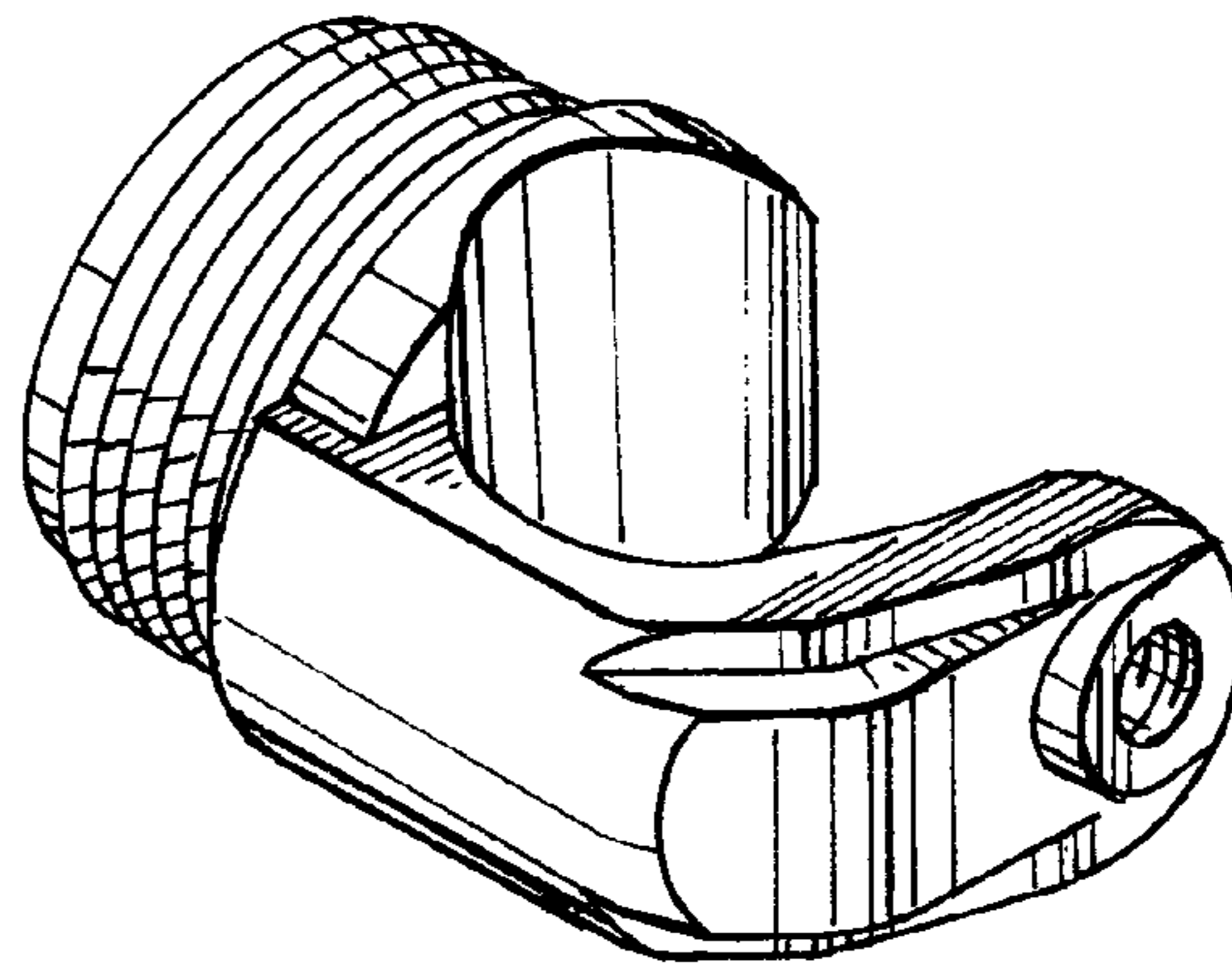

**FIG. 3**

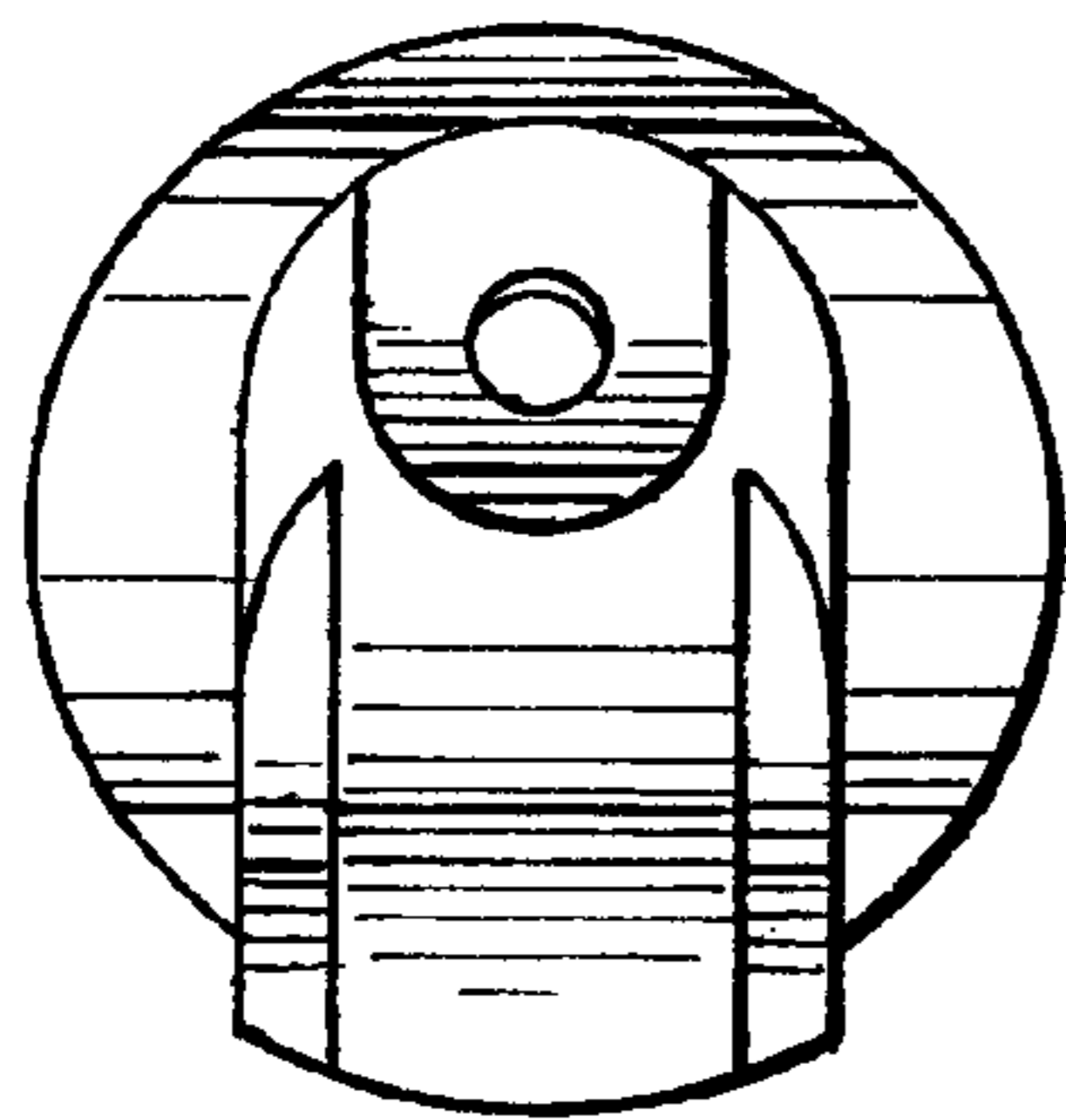

**FIG. 4**

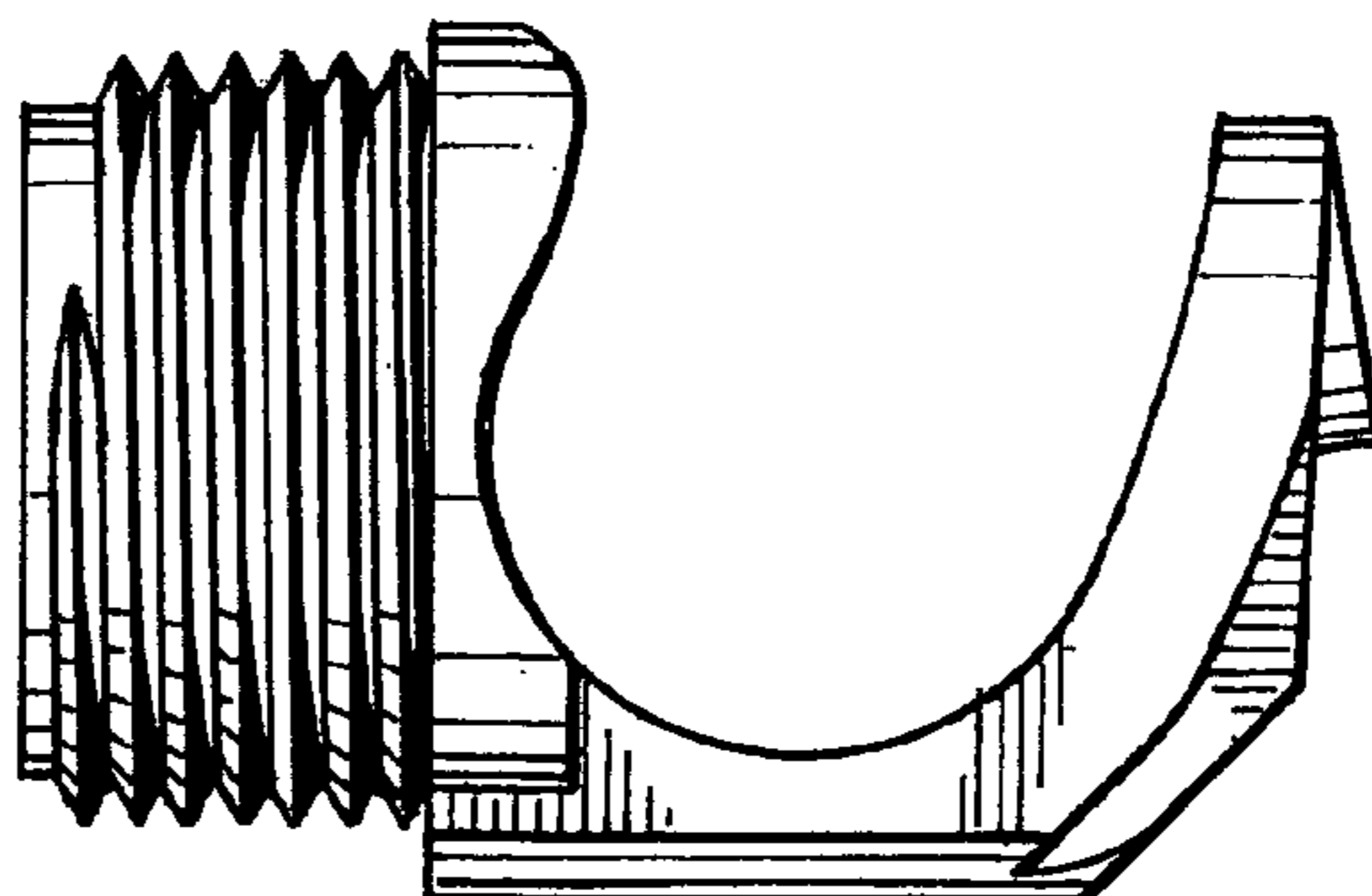

**FIG. 5**

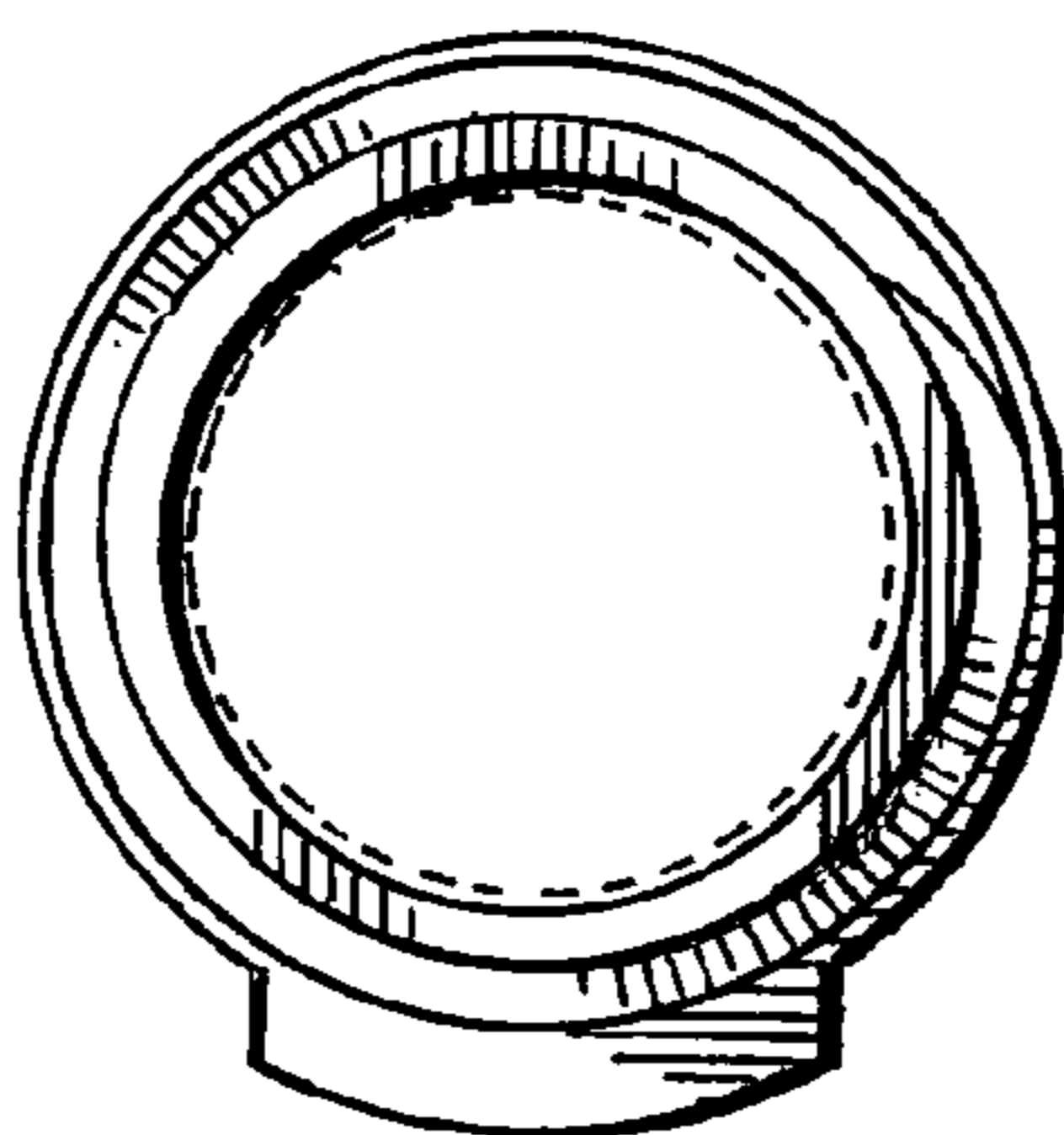

**FIG. 6**

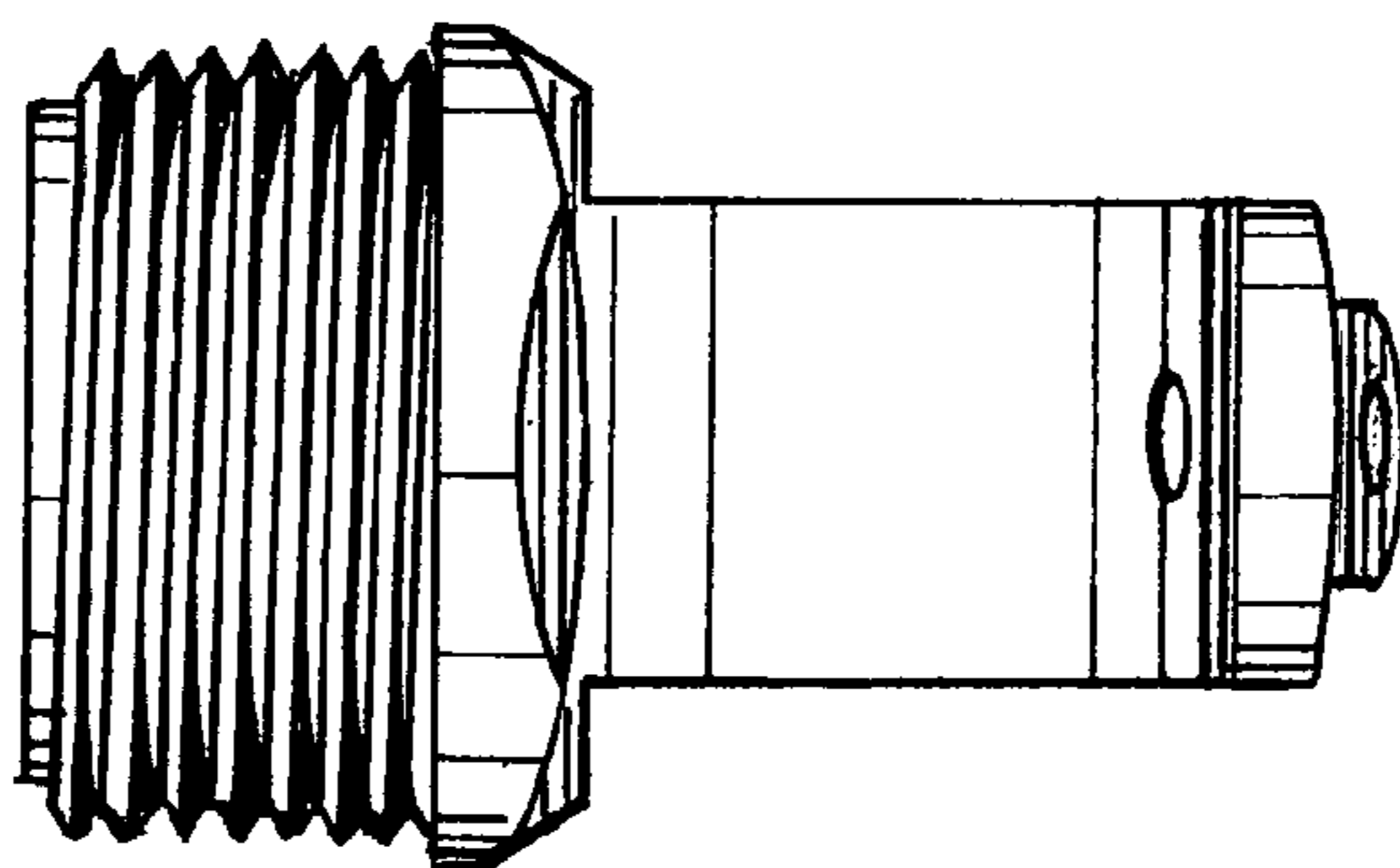

**FIG. 7**

