



US00D625014S

(12) **United States Design Patent**
Hansen et al.

(10) **Patent No.:** **US D625,014 S**
(45) **Date of Patent:** **** Oct. 5, 2010**

(54) **MEDICAL DEVICE STAND DOCKING HEAD**

(75) Inventors: **Joshua M. Hansen**, Everett, WA (US);
Daniel Davidson, Seattle, WA (US);
Richard A. Fine, Mercer Island, WA (US)

(73) Assignee: **SonoSite, Inc.**, Bothell, WA (US)

(**) Term: **14 Years**

(21) Appl. No.: **29/357,524**

(22) Filed: **Mar. 12, 2010**

(51) **LOC (9) Cl.** **24-01**

(52) **U.S. Cl.** **D24/186**

(58) **Field of Classification Search** D24/107,
D24/158, 160, 185-186, 231, 232, 111, 169,
D24/217; 128/915-916, 922, 660.01, 660.02,
128/660.03, 660.07, 653; 600/437-457;
248/918; D14/434, 447, 217; D13/123,
D13/107-108; D10/52

See application file for complete search history.

(56) **References Cited**

U.S. PATENT DOCUMENTS

D354,277 S * 1/1995 Kuzumoto et al. D14/434
(Continued)

Primary Examiner—T. Chase Nelson

Assistant Examiner—Mark Cavanna

(74) *Attorney, Agent, or Firm*—Fulbright & Jaworski L.L.P.

(57) **CLAIM**

The ornamental design for a medical device stand docking head, as shown and described.

DESCRIPTION

This application is related to copending U.S. application Ser. No. 29/357,526, filed concurrently herewith and entitled “Medical Device Stand Docking Station,” and U.S. patent application Ser. No. 12/616,642, filed Nov. 11, 2009 and entitled “Charging Station for Cordless Ultrasound Cart,” the disclosures of which are incorporated herein by reference.

FIG. 1 depicts a perspective view of a medical device stand docking head of our new design, with the point of connection for interfacing with a medical device stand docking station, the switch interlock, and the rear portion for attaching to a

medical device stand shown in phantom for environmental purposes only and forming no part of the claimed embodiment;

FIG. 2 is a front elevation view of the medical device stand docking head of FIG. 1, with the point of connection for interfacing with a medical device stand docking station, the switch interlock, and the rear portion for attaching to a medical device stand shown in phantom for environmental purposes only and forming no part of the claimed embodiment;

FIG. 3 is a rear elevation view of the medical device stand docking head of FIG. 1, with the point of connection for interfacing with a medical device stand docking station and the rear portion for attaching to a medical device stand shown in phantom for environmental purposes only and forming no part of the claimed embodiment;

FIG. 4 is a left elevation view of the medical device stand docking head of FIG. 1, with the rear portion for attaching to a medical device stand shown in phantom for environmental purposes only and forming no part of the claimed embodiment;

FIG. 5 is a right elevation view of the medical device stand docking head of FIG. 1, with the rear portion for attaching to a medical device stand shown in phantom for environmental purposes only and forming no part of the claimed embodiment;

FIG. 6 is a top plan view of the medical device stand docking head of FIG. 1, with the rear portion for attaching to a medical device stand shown in phantom for environmental purposes only and forming no part of the claimed embodiment; and,

FIG. 7 is a bottom plan view of the medical device stand docking head of FIG. 1, with the point of connection for interfacing with a medical device stand docking station and the rear portion for attaching to a medical device stand shown in phantom for environmental purposes only and forming no part of the claimed embodiment.

It should be understood that the labels used herein for describing orientation (e.g., front, rear, top, bottom, left, and right) are merely for reference, and the design may be disposed in any manner and still be within the scope of the present invention. The portions of the article in broken lines are shown for illustrative purposes only and form no part of the claimed design.

1 Claim, 6 Drawing Sheets

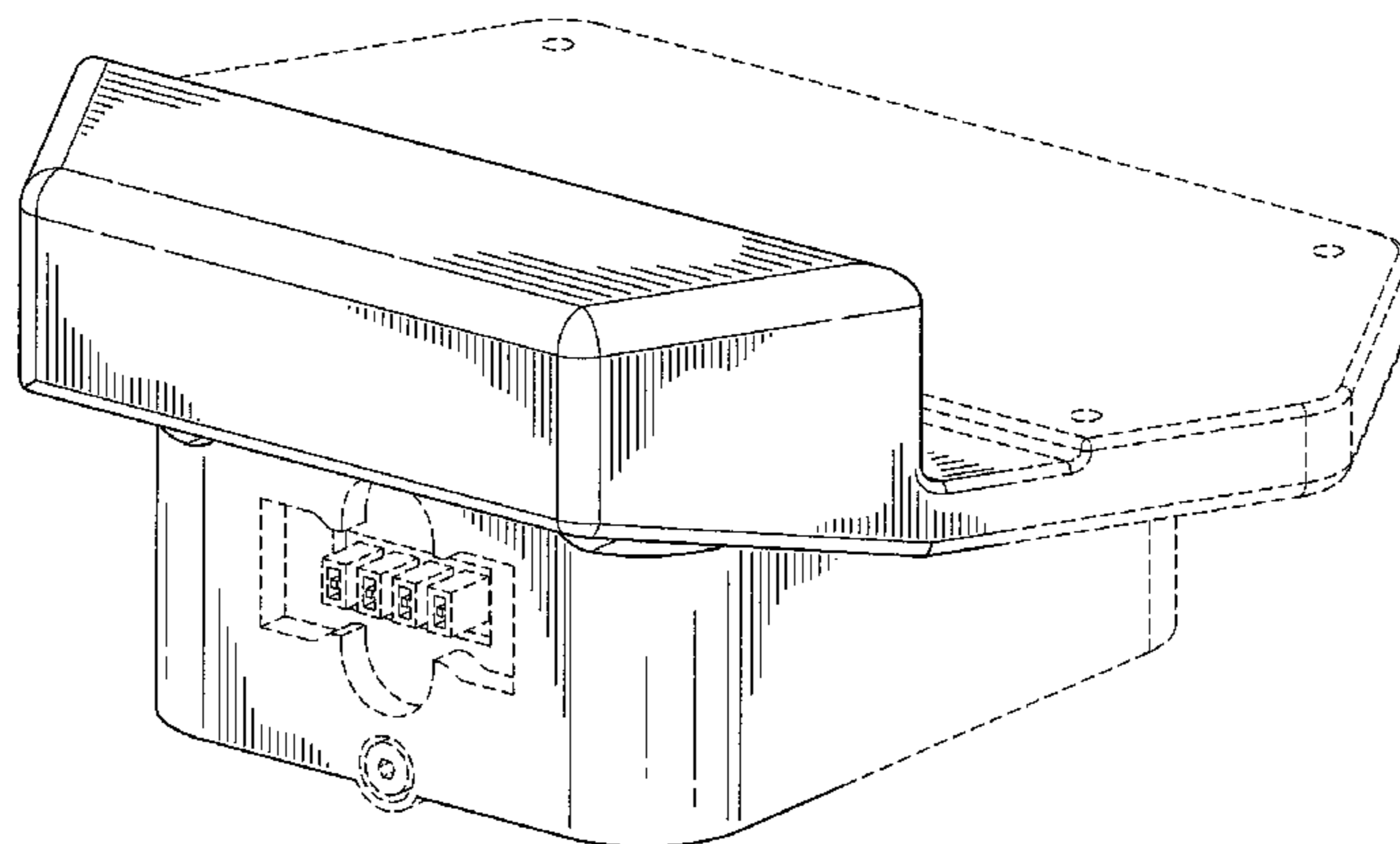

US D625,014 S

Page 2

U.S. PATENT DOCUMENTS

D369,789	S *	5/1996	Lucente et al.	D14/434	D516,026	S *	2/2006	Barrett et al.	D24/186
D411,835	S *	7/1999	Mizusugi et al.	D14/434	7,009,840	B2	3/2006	Clark et al.	
D415,740	S *	10/1999	Lee et al.	D14/434	D544,962	S *	6/2007	Diener et al.	D24/186
D430,882	S *	9/2000	Tsai	D14/434	D546,965	S *	7/2007	Arce et al.	D24/217
D432,082	S *	10/2000	Chang	D13/123	D552,185	S *	10/2007	Hussaini et al.	D14/434
D434,142	S *	11/2000	Cheney et al.	D24/111	D569,981	S *	5/2008	Collins	D24/186
D446,854	S *	8/2001	Cheney et al.	D24/111	D576,999	S *	9/2008	Tofflinger	D14/168
D452,564	S *	12/2001	Micinski et al.	D24/169	D583,820	S *	12/2008	O'Shea	D14/434
D454,131	S *	3/2002	Lord	D14/434	D597,865	S *	8/2009	Bernard et al.	D10/52
D461,814	S *	8/2002	Felix et al.	D13/108	D600,813	S *	9/2009	Bell et al.	D24/169
D466,122	S *	11/2002	Moody	D14/434	D601,258	S *	9/2009	Bell et al.	D24/169
6,493,220	B1	12/2002	Clark et al.		7,594,668	B2	9/2009	Arceta et al.	
D486,492	S *	2/2004	Sheu et al.	D14/447	7,612,999	B2	11/2009	Clark et al.	
6,721,178	B1	4/2004	Clark et al.		7,621,544	B2	11/2009	Rossini	
D506,972	S *	7/2005	Parel et al.	D13/107	D608,350	S *	1/2010	Bo	D14/217
D511,008	S *	10/2005	Ryan	D24/186	D609,349	S *	2/2010	Pelissier et al.	D24/186
6,980,419	B2	12/2005	Smith et al.		D616,890	S *	6/2010	Lewandowski et al.	D14/434

* cited by examiner

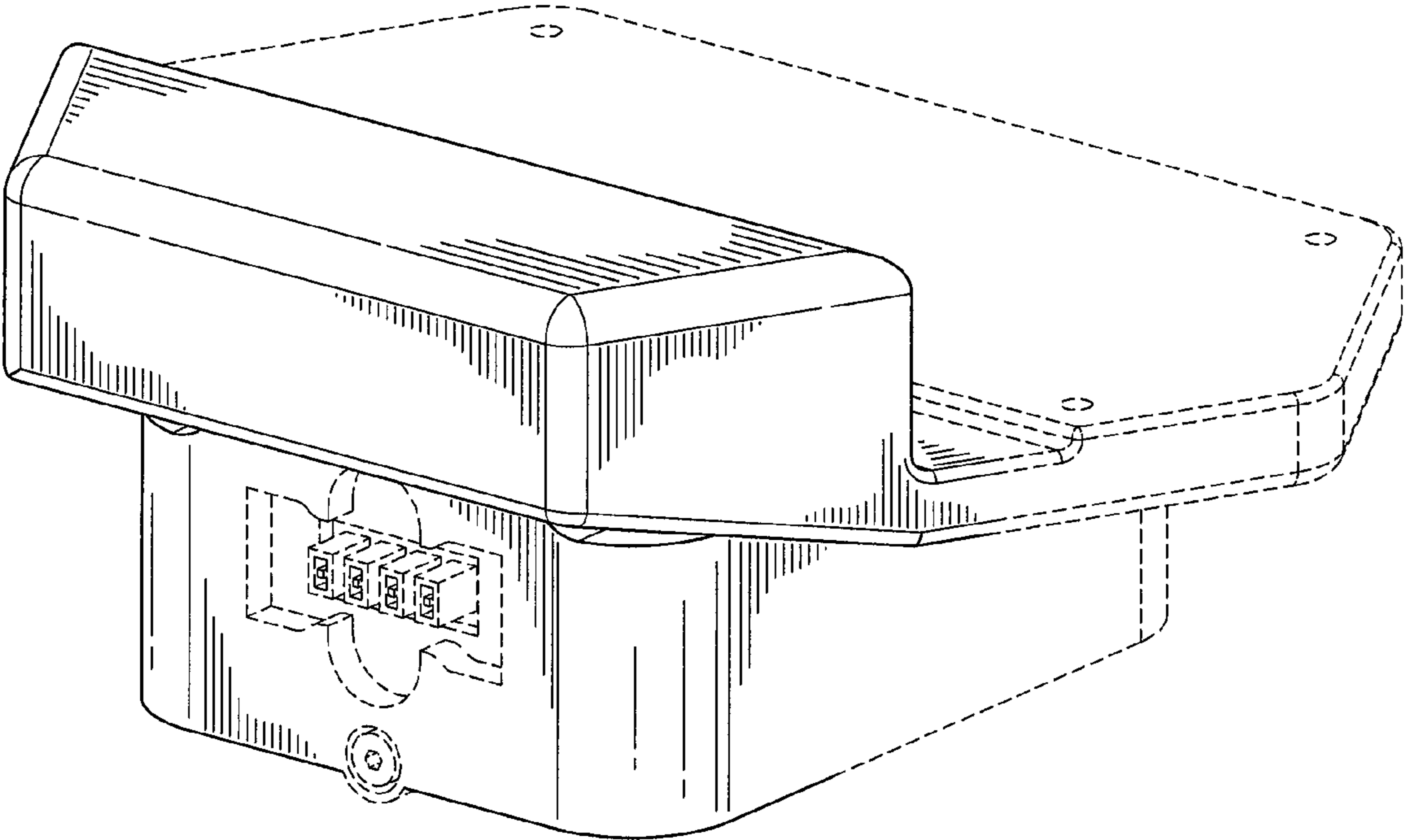

FIG. 1

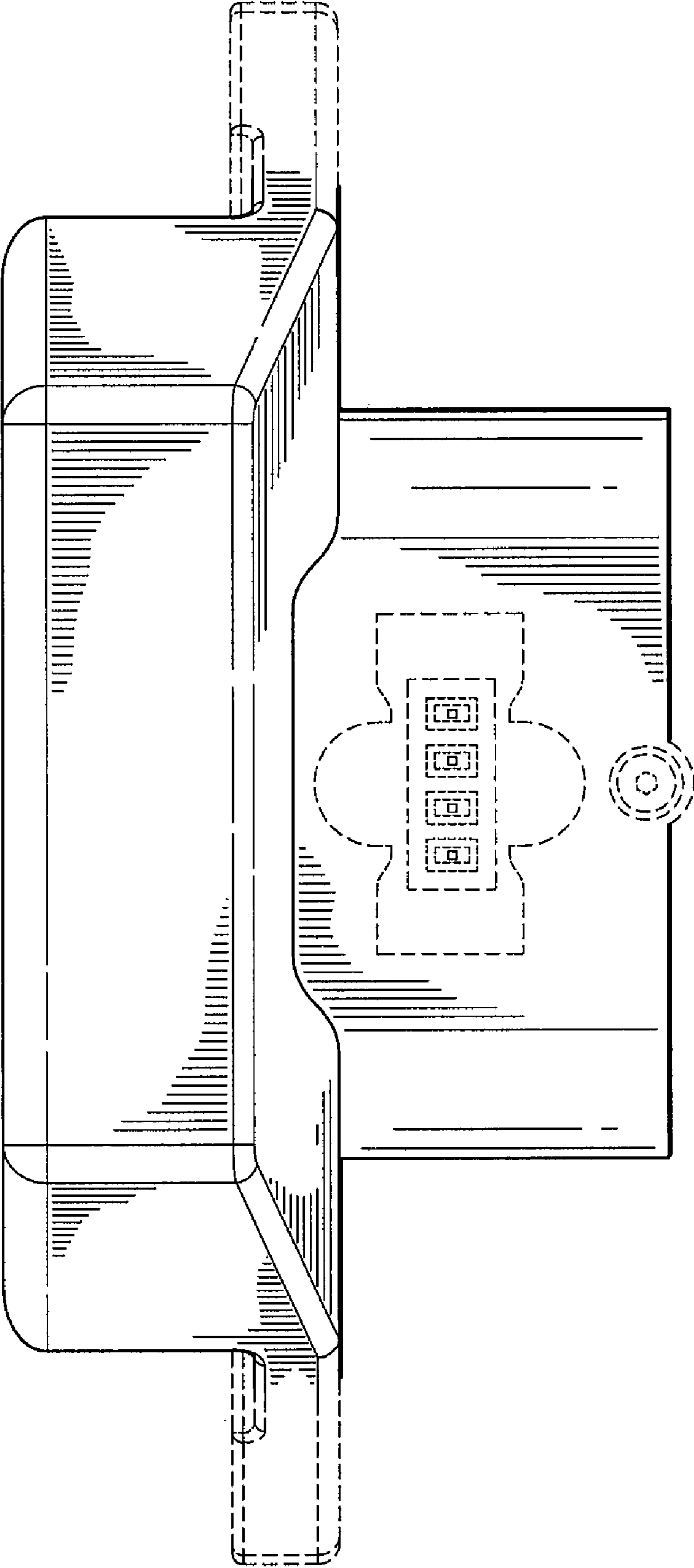

FIG. 2

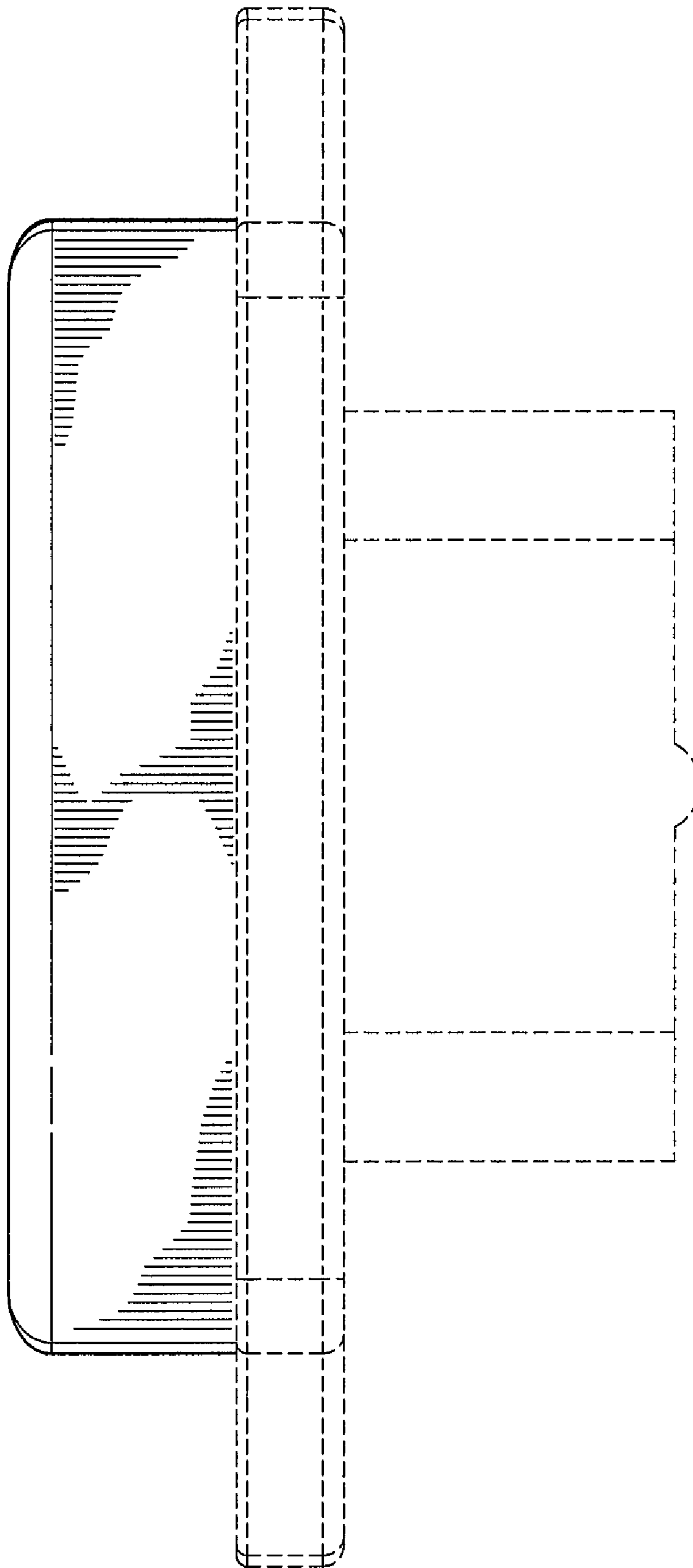

FIG. 3

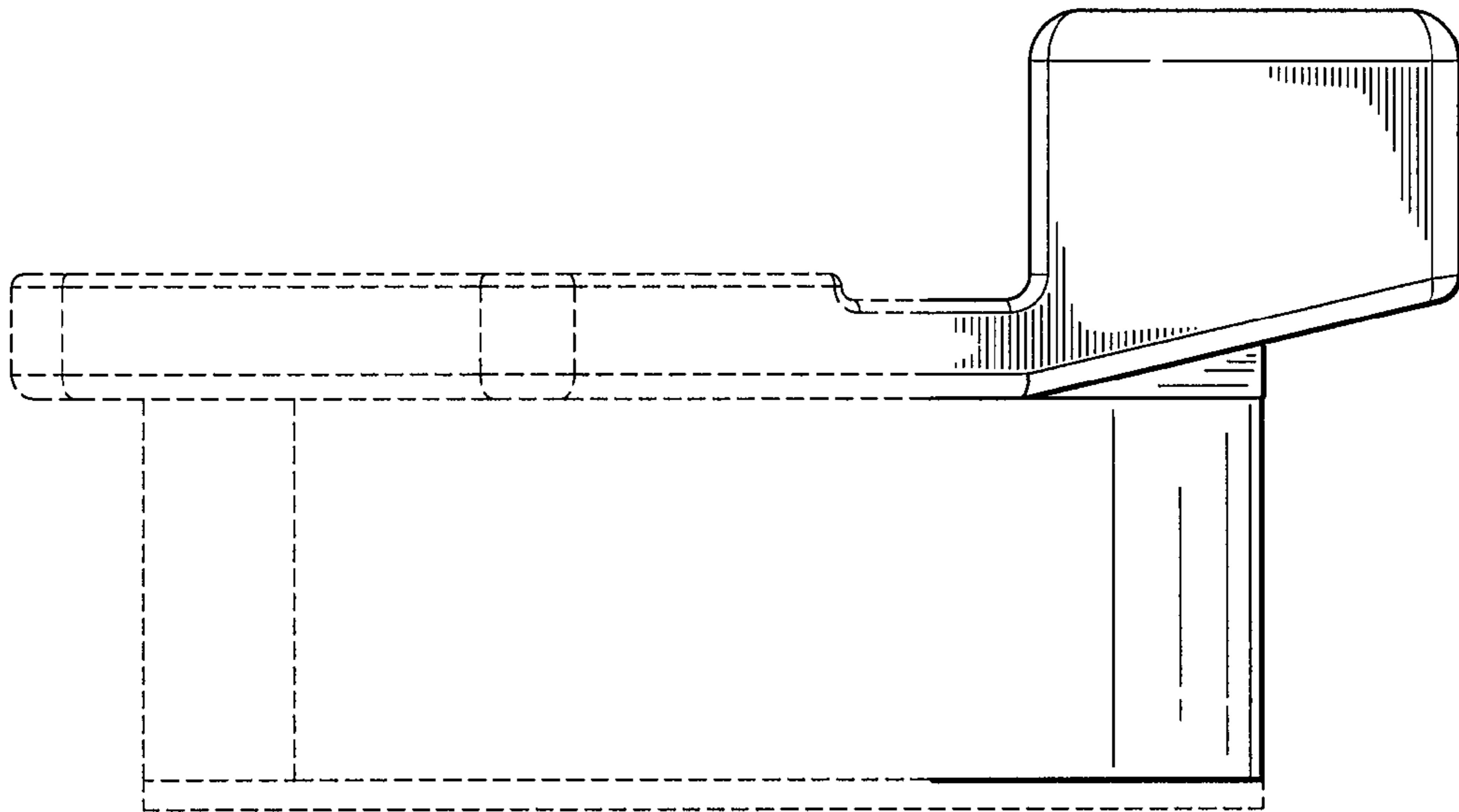

FIG. 4

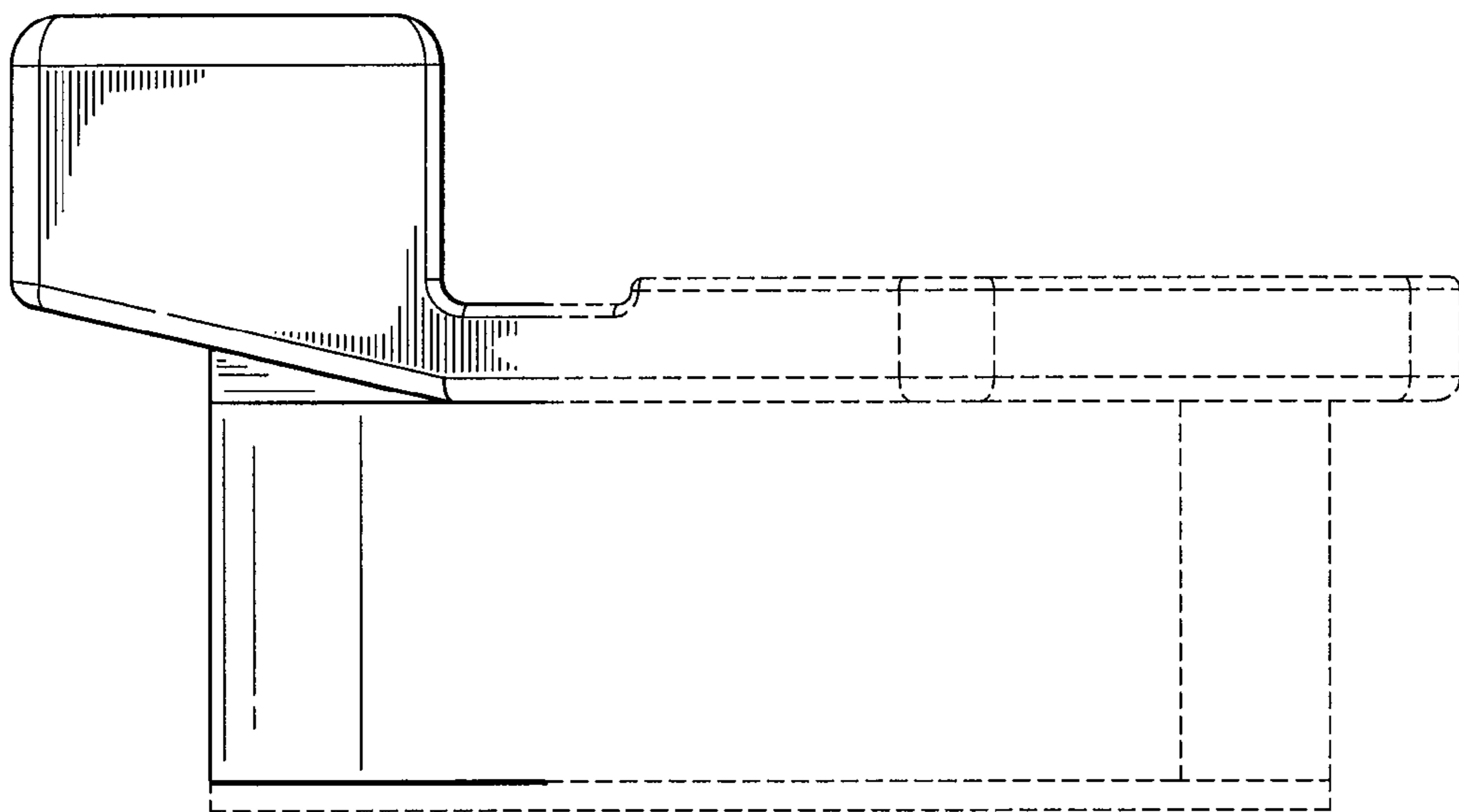

FIG. 5

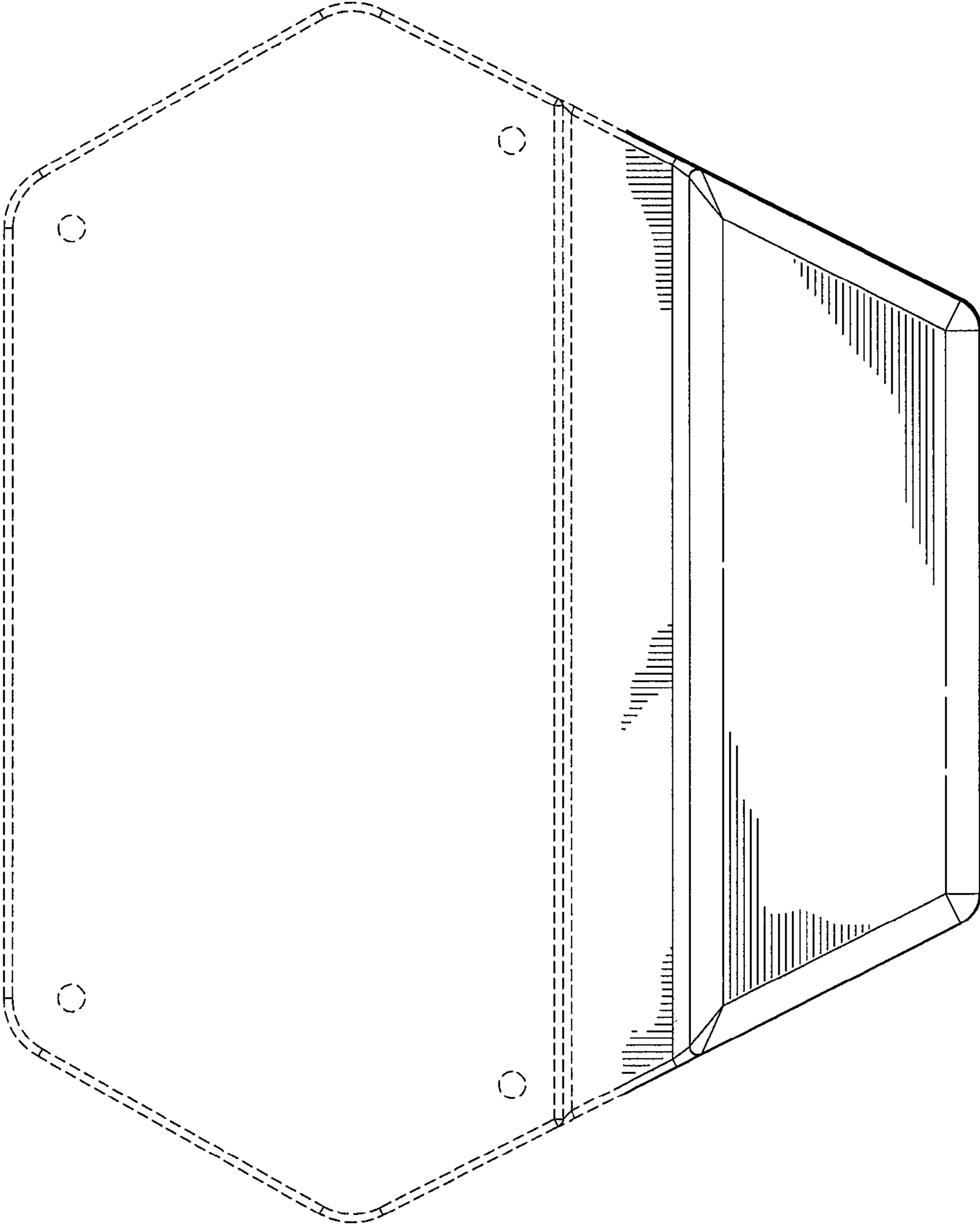

FIG. 6

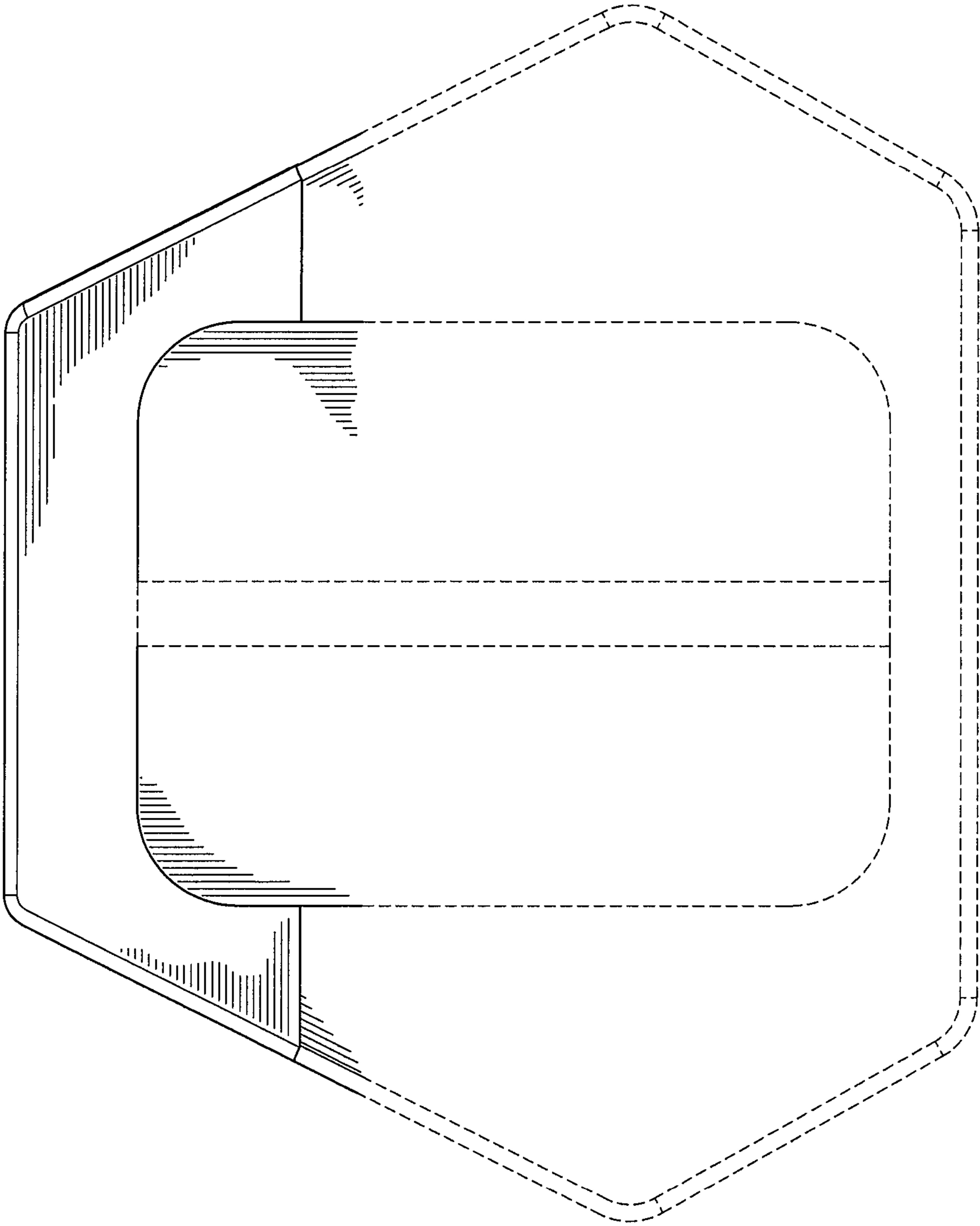

FIG. 7