



US00D624745S

(12) **United States Design Patent**
Henderson

(10) **Patent No.:** **US D624,745 S**
(45) **Date of Patent:** **** Oct. 5, 2010**

(54) **SHOE UPPER**

D614,387 S * 4/2010 Rasmussen D2/972

(75) Inventor: **Jeffrey A. Henderson**, Beaverton, OR (US)

(73) Assignee: **Nike, Inc.**, Beaverton, OR (US)

(**) Term: **14 Years**

(21) Appl. No.: **29/365,979**

(22) Filed: **Jul. 16, 2010**

(51) **LOC (9) Cl.** **02-99**

(52) **U.S. Cl.** **D2/972**

(58) **Field of Classification Search** D2/896,
D2/902, 906-908, 943, 944, 969, 972-974;
36/45-49, 50.1, 77 M, 77 R, 83, 88, 113,
36/114, 126-131

See application file for complete search history.

(56) **References Cited**

U.S. PATENT DOCUMENTS

D283,364 S	4/1986	Gamm	
D298,283 S	11/1988	Swett et al.	
D319,722 S	9/1991	Hatfield	
D322,878 S	1/1992	Hatfield	
D345,253 S	3/1994	Lucas	
D345,452 S	3/1994	Lucas	
D347,109 S	5/1994	Avar	
D348,977 S	7/1994	Koh	
D355,756 S	2/1995	Vestuti	
D361,426 S	8/1995	Baker	
D386,896 S	12/1997	Fogg	
D479,392 S	9/2003	Hillyer	
D481,530 S	11/2003	Hillyer	
D489,168 S	5/2004	Laberge	
D512,213 S	12/2005	Hlavacs	
D543,682 S	6/2007	Matis et al.	
D576,400 S	9/2008	Grenet et al.	
D595,498 S	7/2009	Dolan	
D605,396 S *	12/2009	Henderson D2/972
D610,341 S *	2/2010	Cooper D2/972

OTHER PUBLICATIONS

- Nike Footwear Catalog, Spring 1991, p. 42; published Jun. 1990.
- Nike Footwear Catalog, Late Spring 1994, p. 6; published Sep. 1993.
- Nike Footwear Catalog, Fall 1994, pp. 28, 32, 38 and 104; published Nov. 1993.
- Nike Footwear Catalog, Fall 1997, p. 6; published Dec. 1996.
- Nike Footwear Catalog, Late Spring 1999, p. M9; published Sep. 1998.
- Nike Footwear Catalog, Spring 2000 (#2), pp. M28 and W39; published Jul. 1999.
- Nike Footwear Catalog, Fall 2001, p. W38; published Nov. 2000.

(Continued)

Primary Examiner—Dominic Simone

(74) *Attorney, Agent, or Firm*—Banner & Witcoff, Ltd.

(57) **CLAIM**

The ornamental design for a shoe upper, as shown and described.

DESCRIPTION

FIG. 1 is a front perspective view of a shoe upper showing my new design;

FIG. 2 is a side view thereof; and,

FIG. 3 is a rear perspective view thereof.

The broken lines immediately adjacent to the shaded area represent unclaimed boundaries of the design. The broken lines showing the three eyelet regions and the remainder of the shoe are for environmental purposes only and form no part of the claimed design.

1 Claim, 3 Drawing Sheets

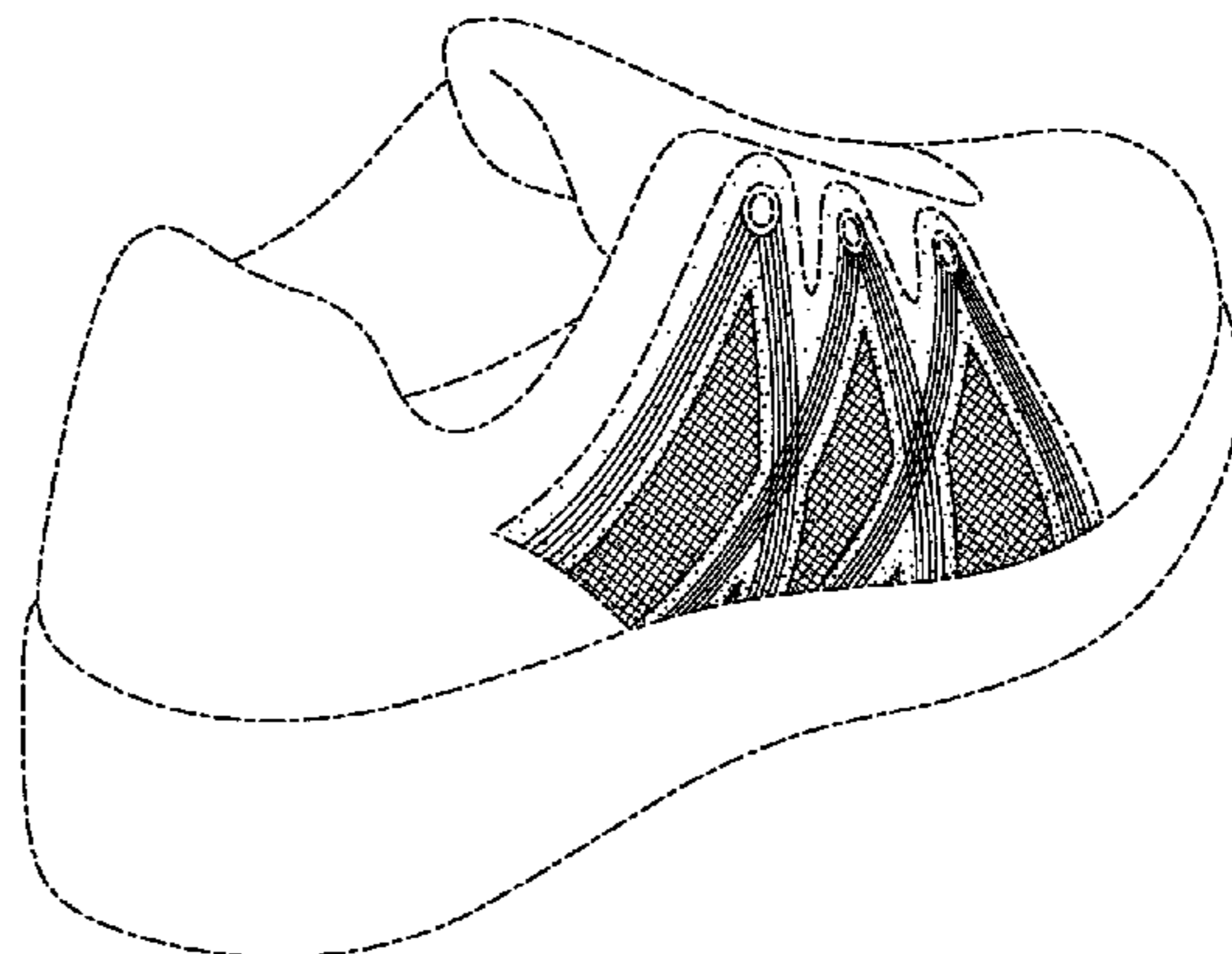
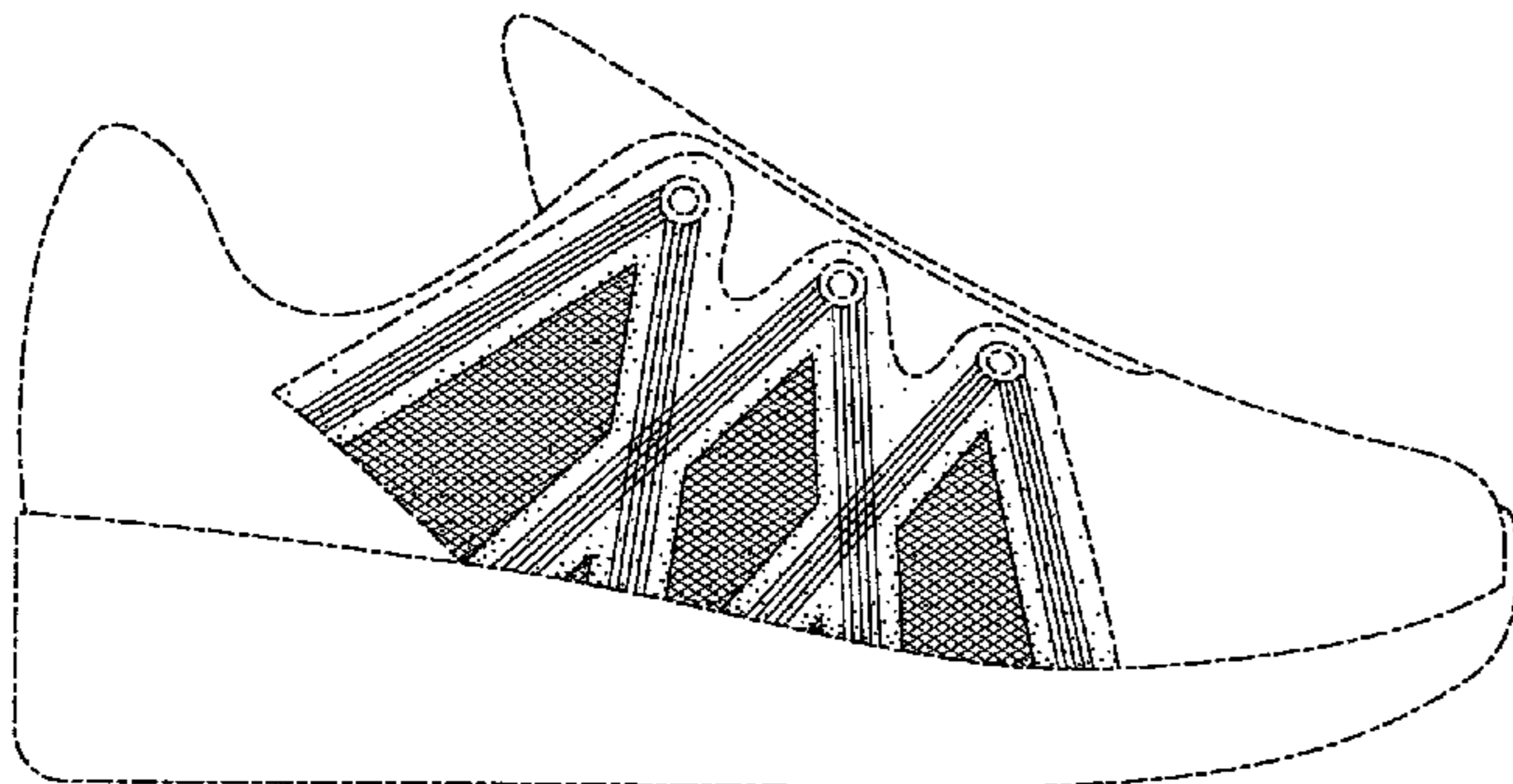

OTHER PUBLICATIONS

Nike Footwear Catalog, Fall 2003, p. M57; published Nov. 2002.
Nike Footwear Catalog, Spring 2005, p. W7; published Jun. 2004.
Nike Footwear Catalog, Holiday 2006, p. 29; published Mar. 2006.
Nike Footwear Catalog, Spring 2008, p. 129; published May 2007.
Nike Footwear Catalog, Holiday 2008, p. 14; published Feb. 2008.

Nike Footwear Catalog, Spring 2009, p. 136; published May 2008.
Nike Footwear Catalog, Summer 2010 Core, p. 11; published Aug. 2009.

Nike Air Max +2009; date unknown but prior to the filing date of the present application.

* cited by examiner

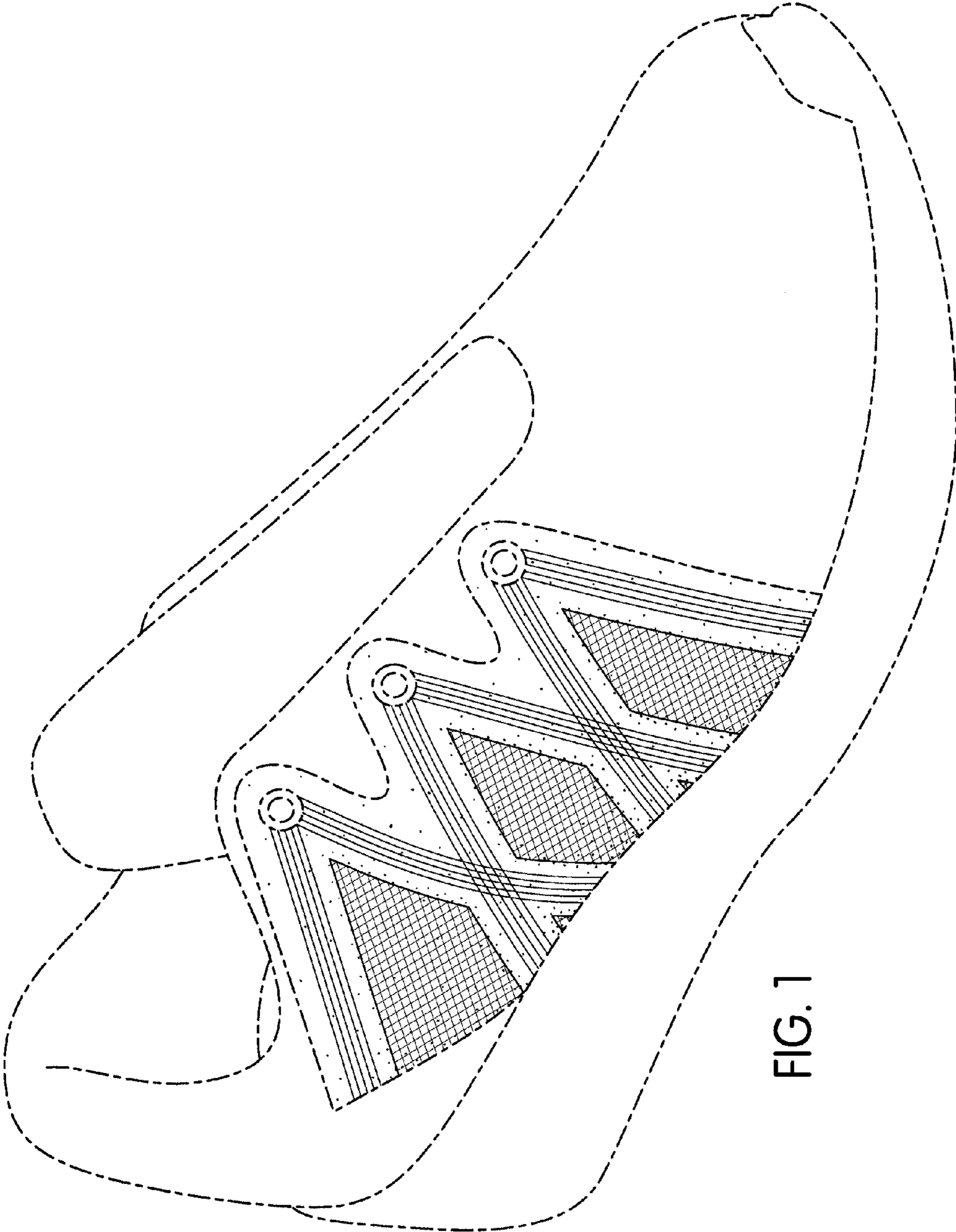

FIG. 1

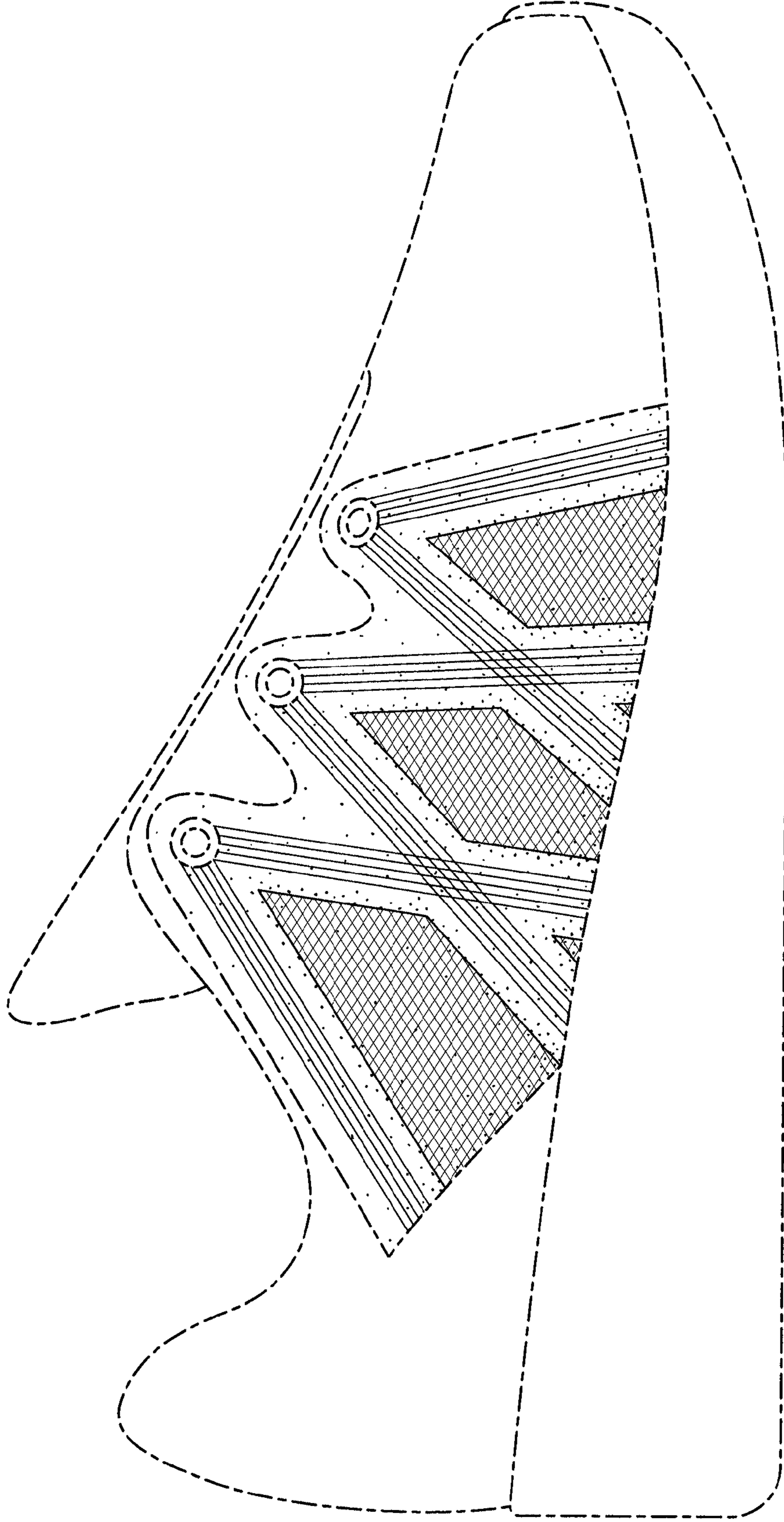

FIG. 2

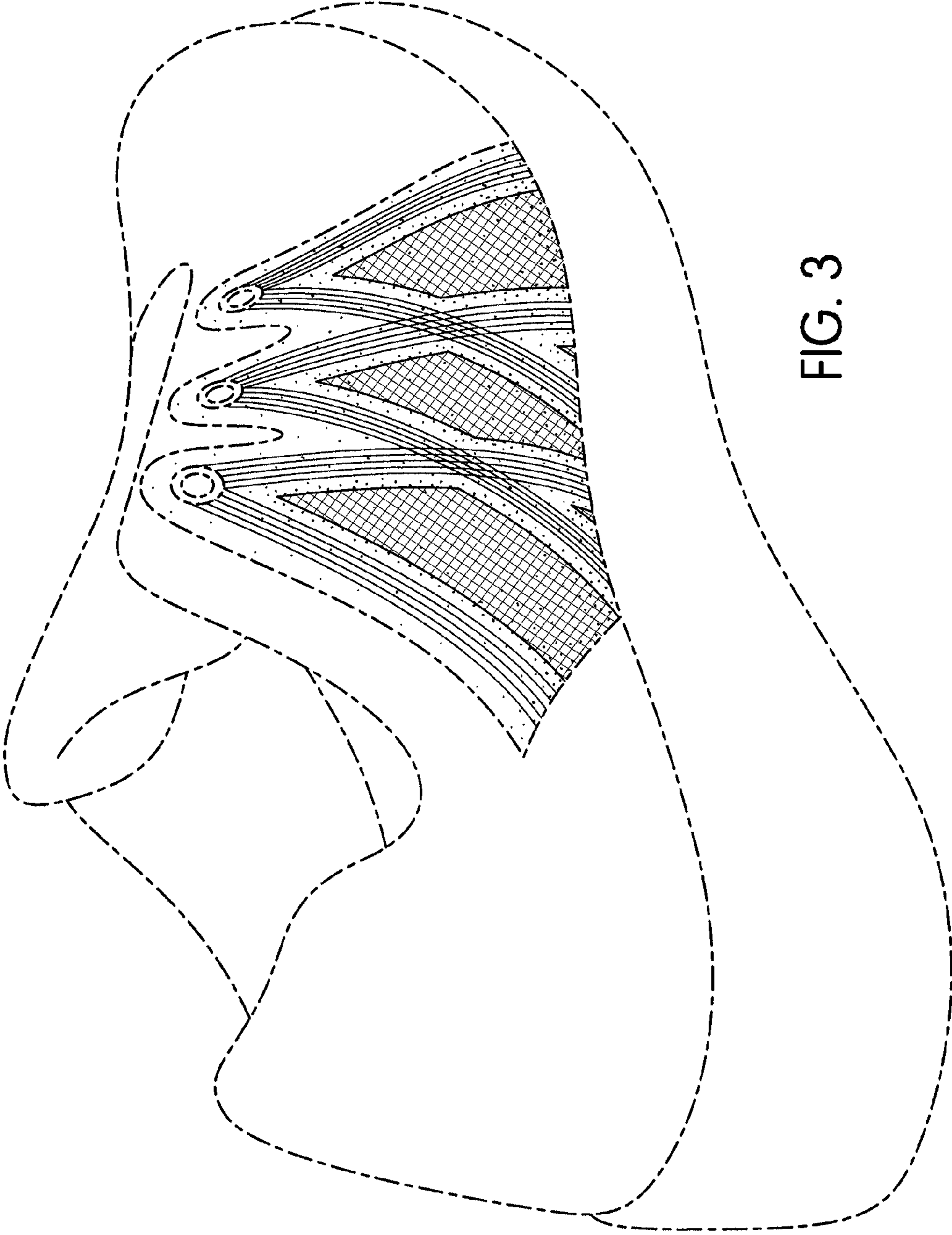

FIG. 3