



US00D624560S

(12) **United States Design Patent**
Suzuki

(10) **Patent No.:** **US D624,560 S**
(45) **Date of Patent:** **** Sep. 28, 2010**

(54) **DIGITAL AUDIO DISK PLAYER**

JP S-1328581 4/2008

(75) Inventor: **Tomohisa Suzuki**, Meguro (JP)

(73) Assignee: **Pioneer Kabushiki Kaisha**, Tokyo (JP)

(**) Term: **14 Years**

(21) Appl. No.: **29/347,232**

(22) Filed: **Nov. 5, 2009**

(30) **Foreign Application Priority Data**

Jul. 14, 2009 (JP) 2009-016027

(51) **LOC (9) Cl.** **14-01**

(52) **U.S. Cl.** **D14/506**

(58) **Field of Classification Search** D14/496,
D14/498-511, 162, 168, 188, 217; 360/99.02,
360/99.07; 369/75.11, 75.21, 77.11, 77.21;
720/601, 612, 619, 649, 655; 455/344, 347-351
See application file for complete search history.

(56) **References Cited**

U.S. PATENT DOCUMENTS

D454,855 S * 3/2002 Nakane D14/168
D505,667 S * 5/2005 Okada D14/502
D512,409 S * 12/2005 Ishizaki D14/168
D512,706 S * 12/2005 Nakane et al. D14/507
D518,022 S * 3/2006 Ishizaki D14/168
D583,798 S * 12/2008 Iijima et al. D14/168

FOREIGN PATENT DOCUMENTS

JP S-1054679 11/1999
JP S-1062032 2/2000
JP S-1118940 8/2001
JP S-1215807 8/2004

OTHER PUBLICATIONS

“Professional Series DVJ-1000”, Brochure; Date Unknown.
“Professional Series CDJ-1000MK3”, Brochure; Date Unknown.
“Professional Series CDJ-800MK2”, Brochure; Date Unknown.
“Professional Series MEP-7000”, Brochure; Date Unknown.
“Performance Series CDJ-200”, Brochure; Date Unknown.
“Performance Series CDJ-100S”, Brochure; Date Unknown.
“Professional Series EFX-I000”, Brochure; Date Unknown.
“Performance Series EFX-500”, Brochure; Date Unknown.
“The Professional CD Player CDJ-1000”, Brochure; Date Unknown.
“The Professional CD Player CDJ-700S”, Brochure; Date Unknown.
“The Performance CD Player CDJ-100S”, Brochure; Date Unknown.

* cited by examiner

Primary Examiner—Nanda Bondade

(74) *Attorney, Agent, or Firm*—Oliff & Berridge, PLC

(57) **CLAIM**

The ornamental design for a digital audio disk player, as shown and described.

DESCRIPTION

FIG. 1 is a perspective view of a digital audio disk player;

FIG. 2 is a top view thereof;

FIG. 3 is bottom view thereof;

FIG. 4 is a front view thereof;

FIG. 5 is a rear view thereof;

FIG. 6 is a left-side view thereof;

FIG. 7 is a right-side view thereof; and,

FIG. 8 is a perspective view thereof in use.

The broken lines depict environmental subject matter only and form no part of the claimed design.

1 Claim, 8 Drawing Sheets

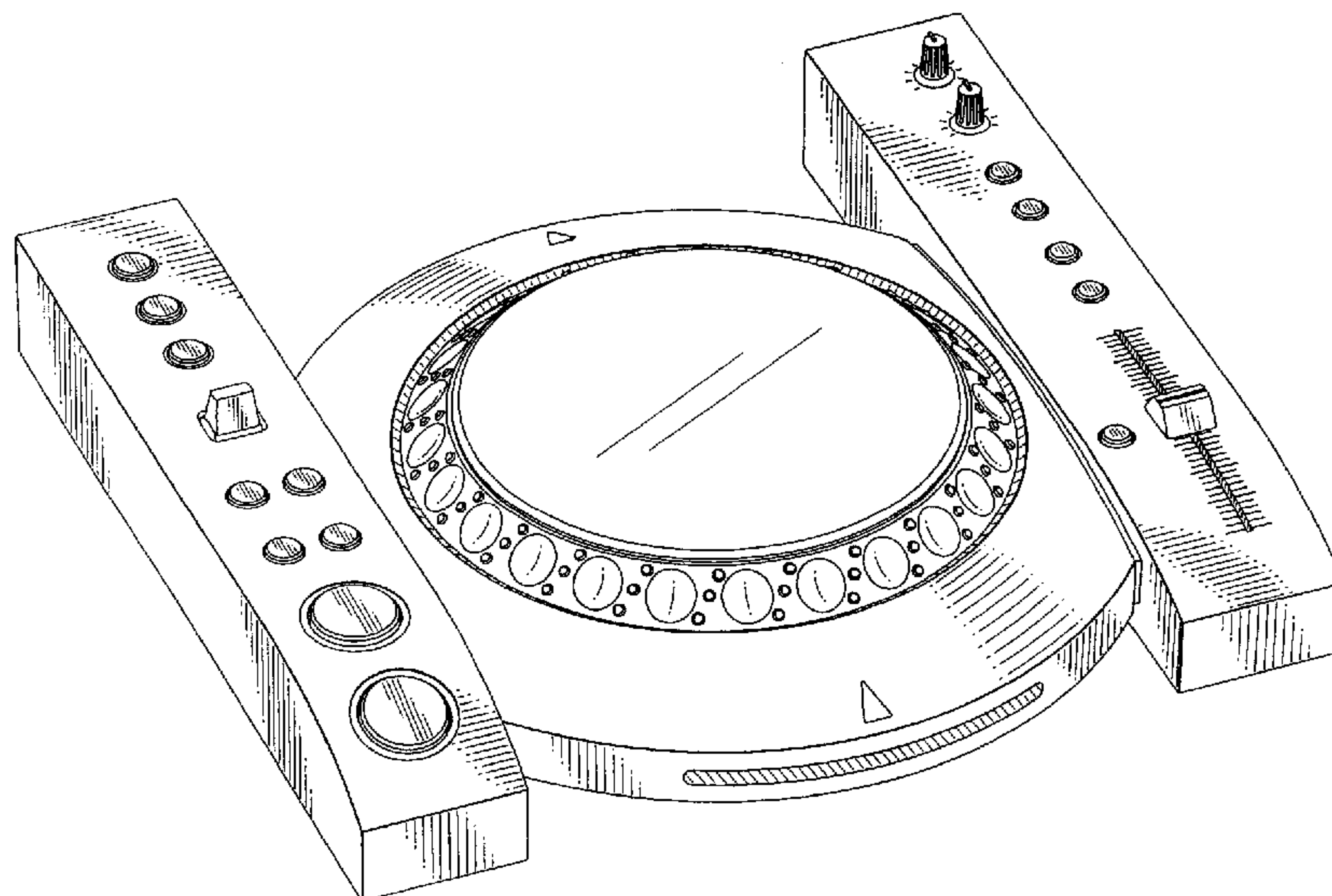

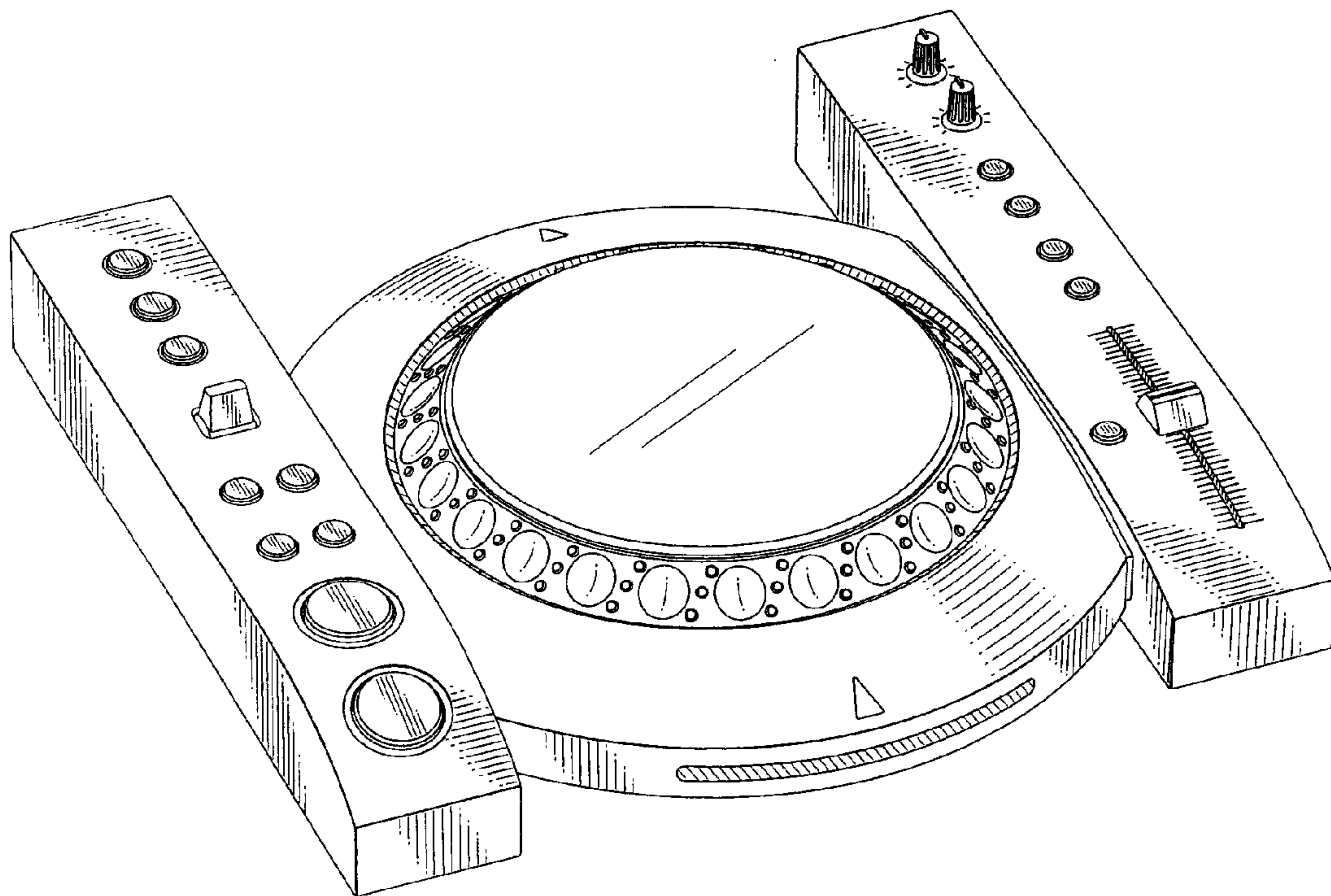

FIG. 1

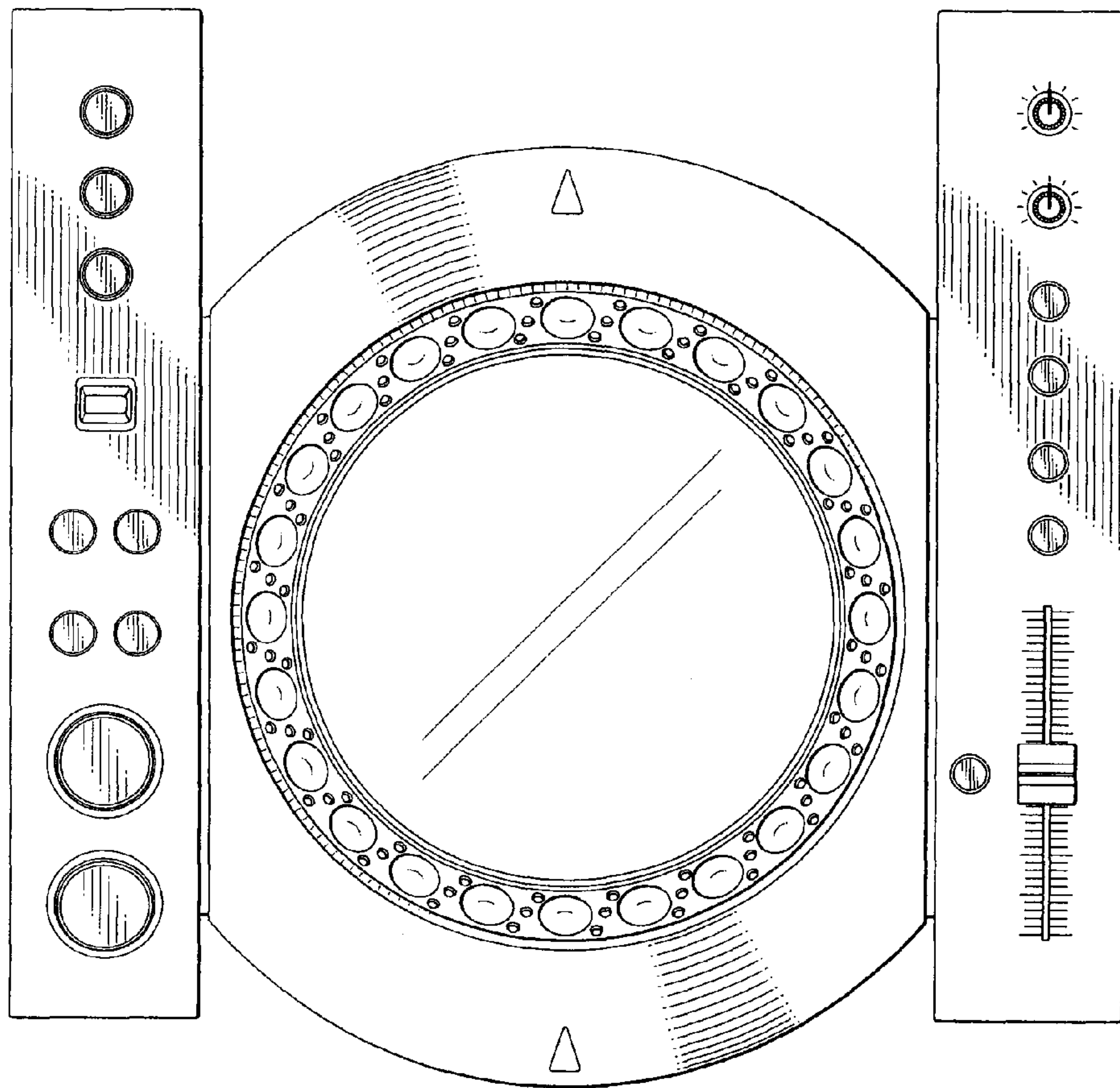

FIG. 2

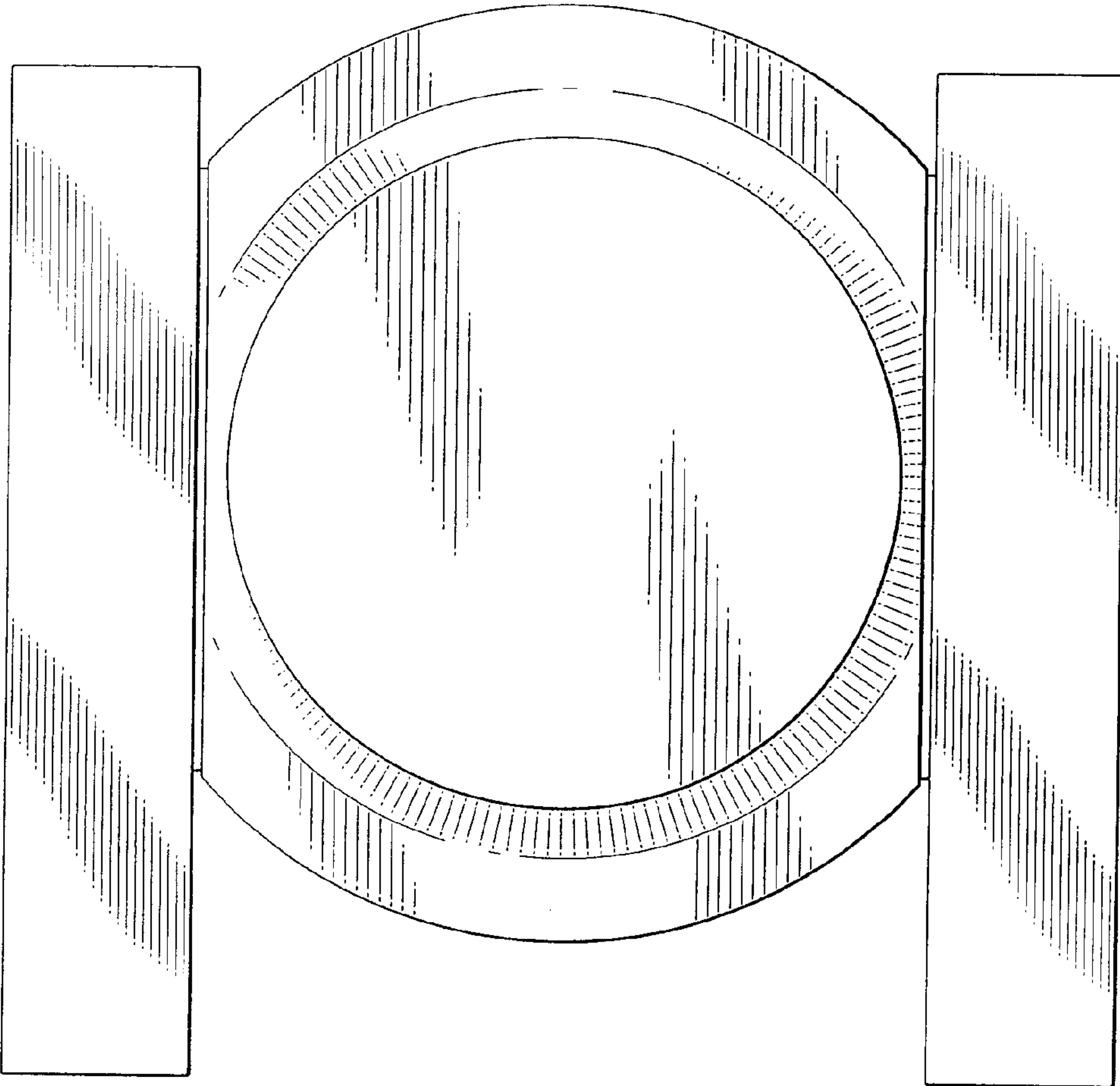

FIG. 3

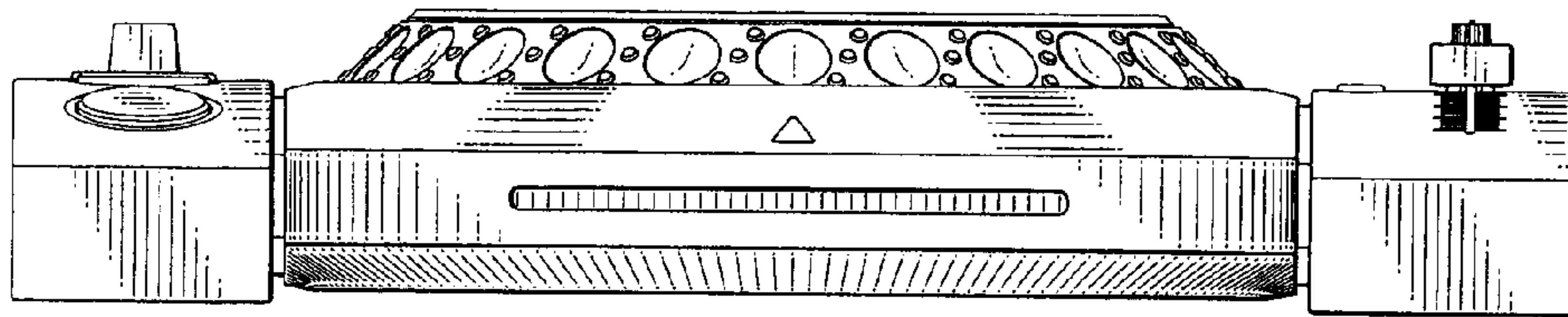

FIG. 4

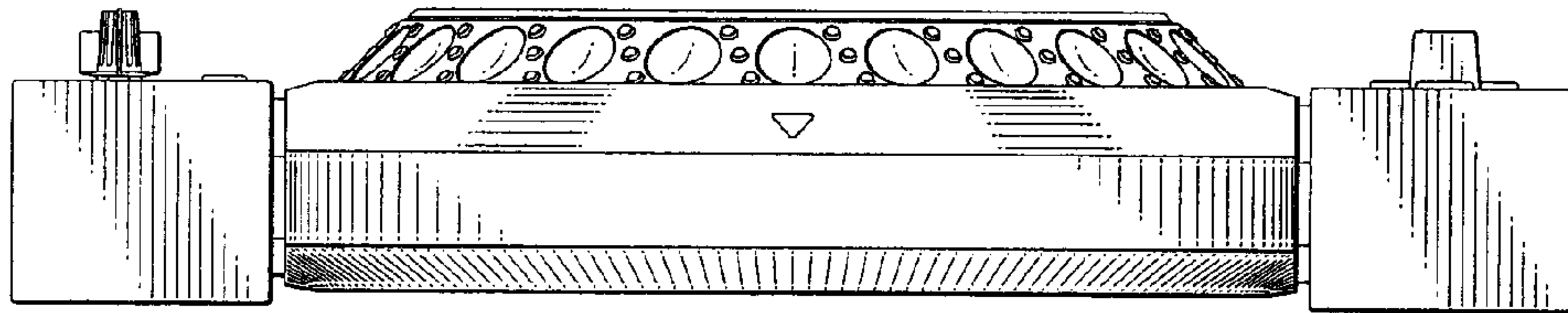

FIG. 5

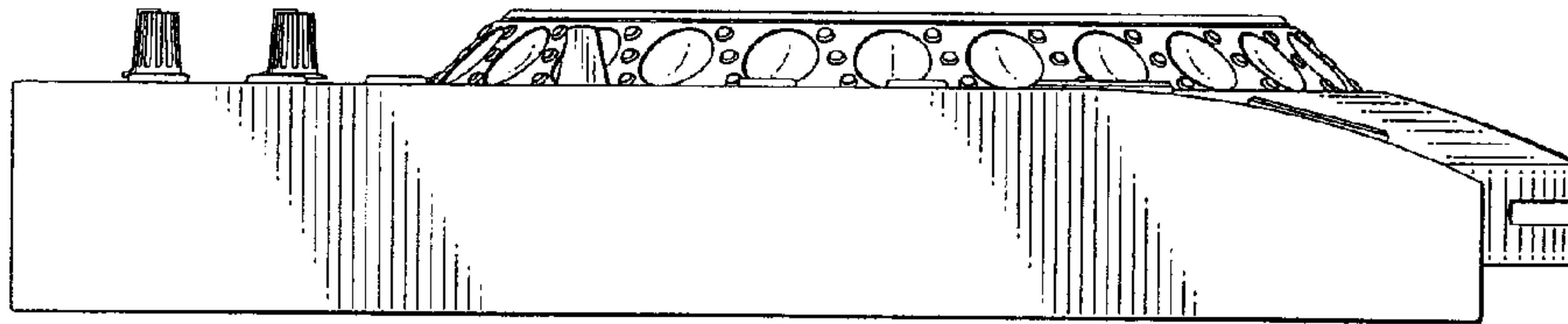

FIG. 6

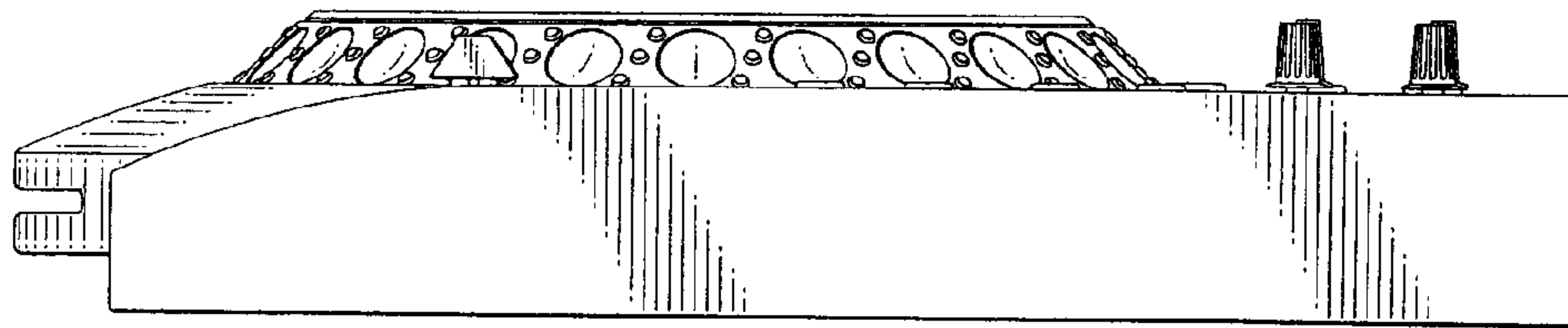

FIG. 7

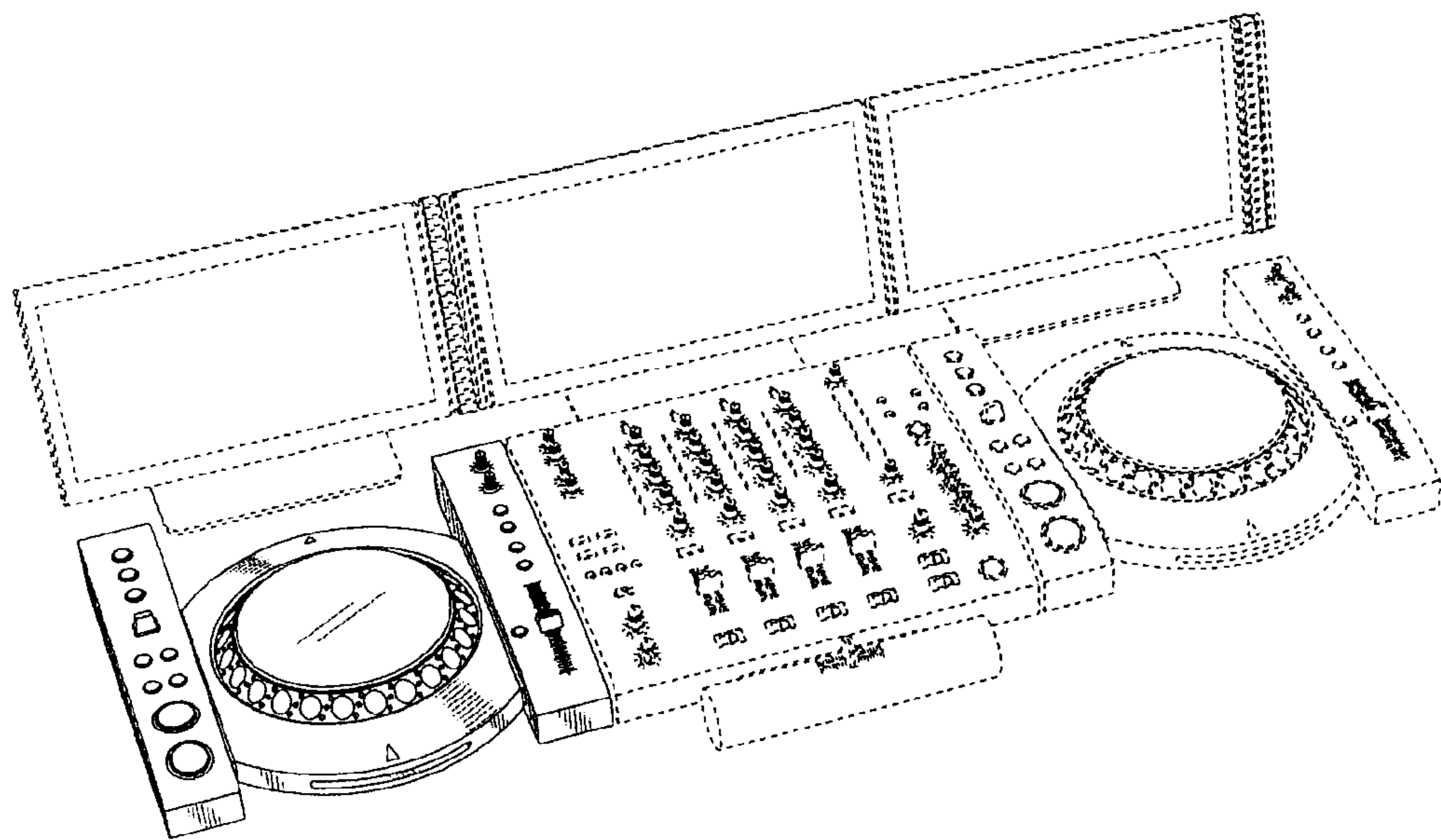

FIG. 8