



US00D624534S

(12) **United States Design Patent**  
**Harrington**

(10) **Patent No.:** **US D624,534 S**

(45) **Date of Patent:** **\*\* Sep. 28, 2010**

(54) **AUDIO ADAPTER PLATE FOR AN  
AUTOMOBILE RADIO**

(76) **Inventor:** **Steven L. Harrington**, 3106 N. Puente  
Ave., Fullerton, CA (US) 92835

(\*\*) **Term:** **14 Years**

(21) **Appl. No.:** **29/350,486**

(22) **Filed:** **Nov. 17, 2009**

(51) **LOC (9) Cl.** ..... **14-01**

(52) **U.S. Cl.** ..... **D14/258**

(58) **Field of Classification Search** ..... D14/496,  
D14/498-511, 168, 188, 157, 217, 257, 258;  
360/99.02, 99.07; 369/75.11, 75.21, 77.11,  
369/77.21; 720/601, 612, 619, 649, 655;  
455/344, 347-351

See application file for complete search history.

(56) **References Cited**

**U.S. PATENT DOCUMENTS**

D395,313 S *	6/1998	Alves et al.	.....	D14/258
D483,753 S *	12/2003	Goodsene et al.	.....	D14/257
D529,479 S *	10/2006	Wolf et al.	.....	D14/188
D558,195 S *	12/2007	Divine et al.	.....	D14/257

\* cited by examiner

*Primary Examiner*—Nanda Bondade  
(74) *Attorney, Agent, or Firm*—QuickPatents, Inc.; Kevin Prince

(57) **CLAIM**

What is claimed is the ornamental design for a audio adapter plate for an automobile radio, as shown and described.

**DESCRIPTION**

FIG. 1 is a perspective view of a audio adapter plate for an automobile radio, showing the new design;

FIG. 2 is a right-side elevational view thereof, the left-side elevational view being a mirror image thereof;

FIG. 3 is a front elevational view thereof;

FIG. 4 is a top plan view thereof;

FIG. 5 is a rear elevational view thereof; and,

FIG. 6 is a bottom plan view thereof.

FIGS. 2 and 3 are on an enlarged scale and FIG. 1 is on a reduced scale.

The broken lines showing a radio in FIG. 1 are included for the purpose of illustrating the invention in use, and form no part of the claimed design.

**1 Claim, 2 Drawing Sheets**

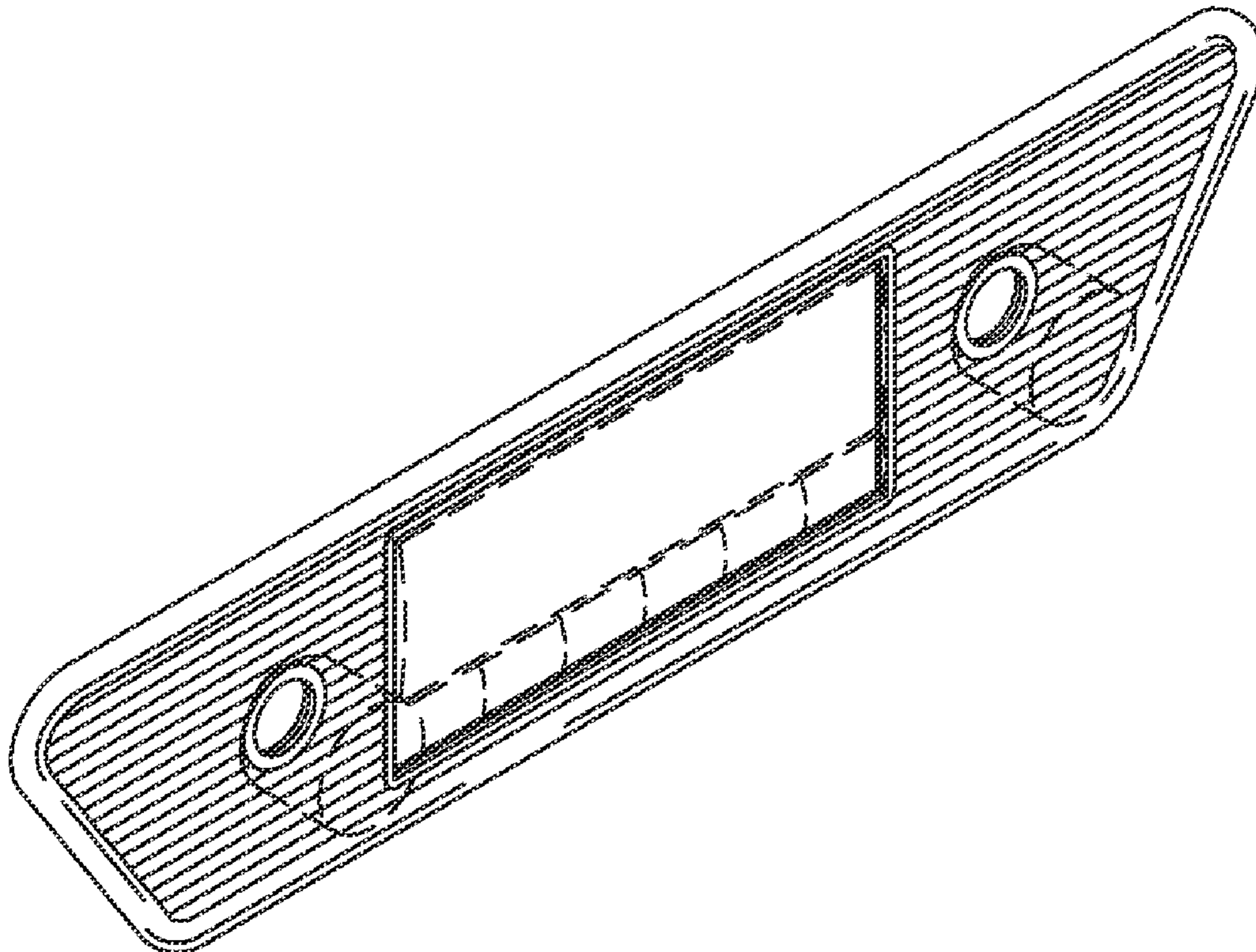

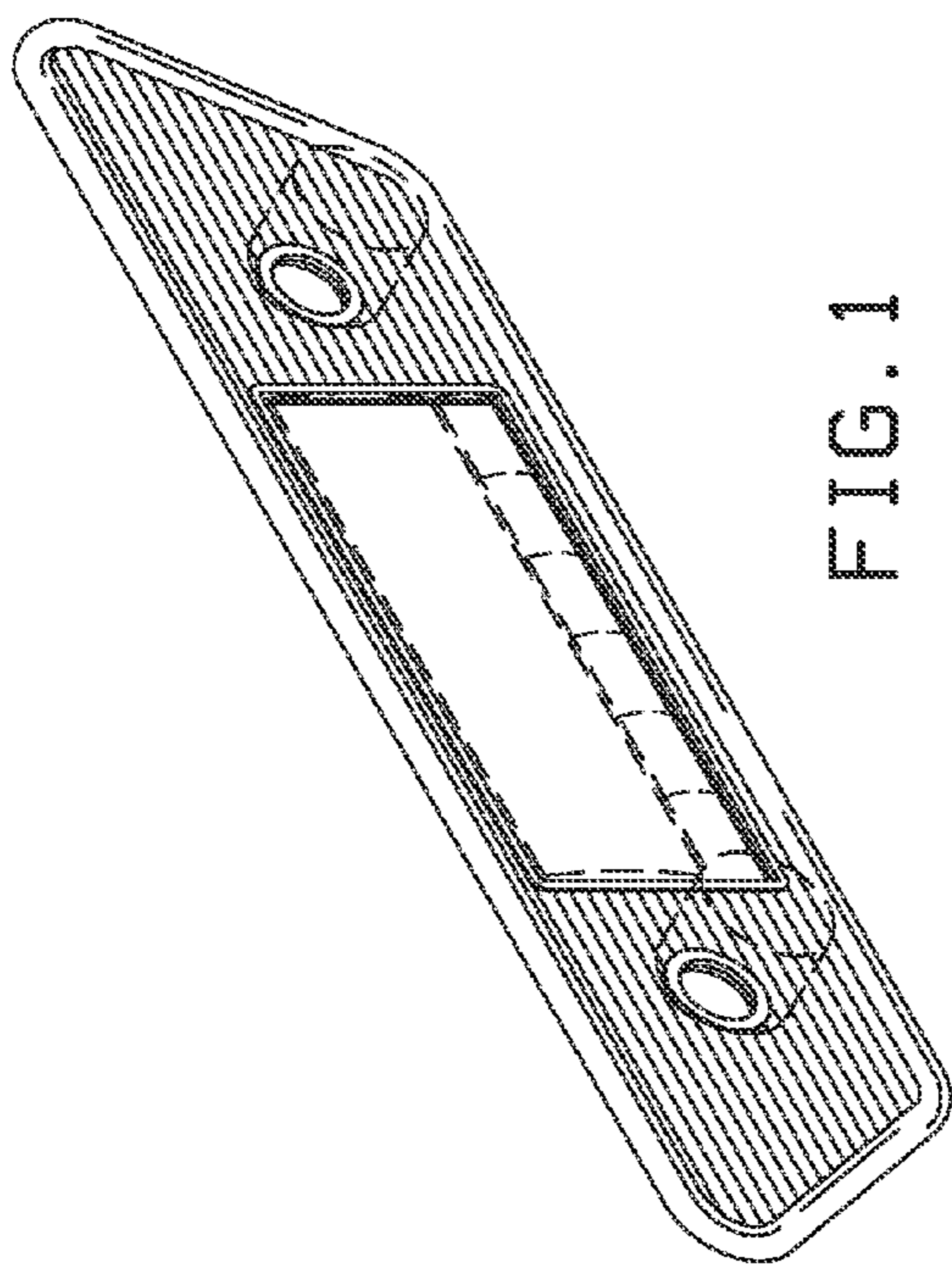

FIG. 1



FIG. 2

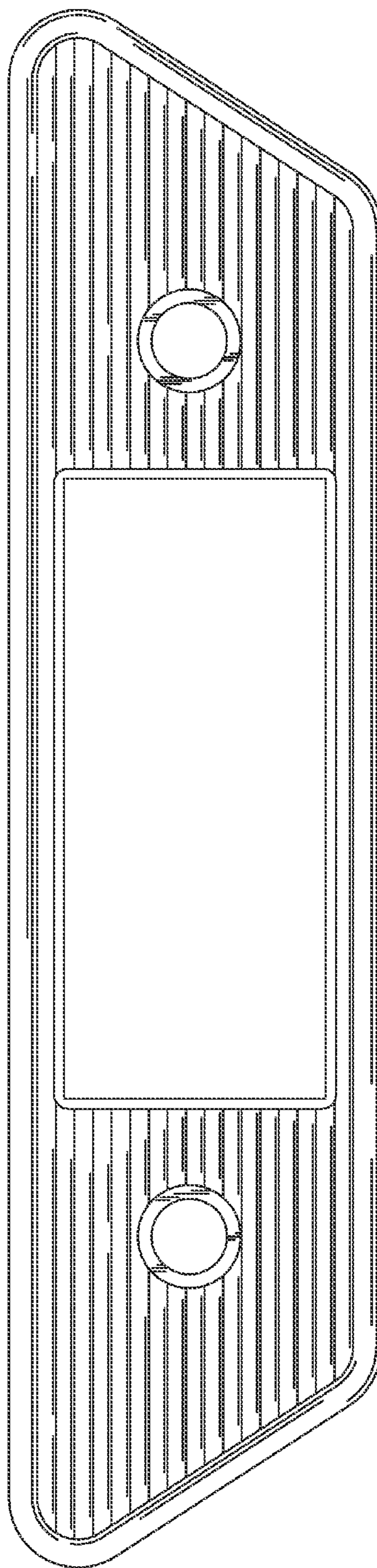

FIG. 3

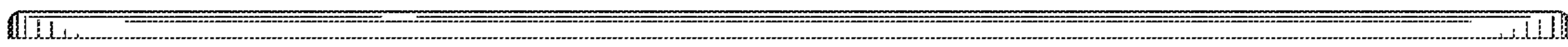

FIG. 4

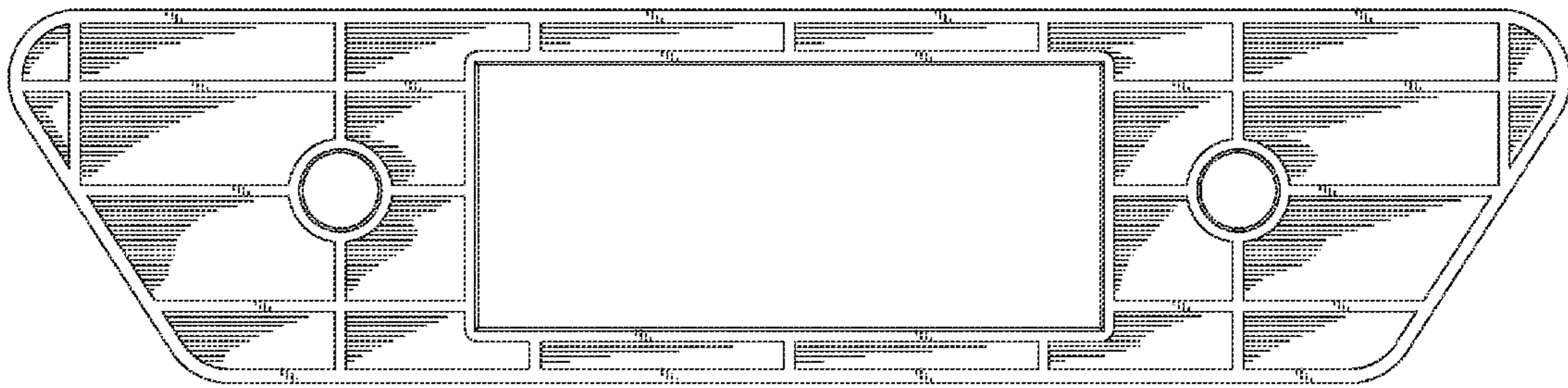

FIG. 5

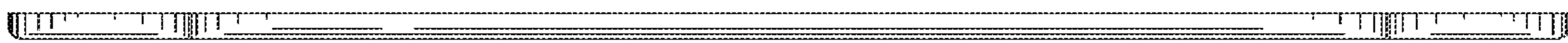

FIG. 6