



US00D624483S

(12) **United States Design Patent**
Schuephaus et al.

(10) **Patent No.:** **US D624,483 S**

(45) **Date of Patent:** **** Sep. 28, 2010**

(54) **CEILING LINING PANEL FOR AN AIRCRAFT CABIN**

(75) Inventors: **Florian Schuephaus**, Hamburg (DE);
Silvan Fiedler, Ulm (DE)

(73) Assignee: **Airbus Deutschland GmbH**, Hamburg (DE)

(**) Term: **14 Years**

(21) Appl. No.: **29/332,422**

(22) Filed: **Feb. 16, 2009**

Related U.S. Application Data

(62) Division of application No. 29/295,859, filed on Oct. 9, 2007.

(30) **Foreign Application Priority Data**

Apr. 18, 2007 (EM) 000709142

(51) **LOC (9) Cl.** **12-07**

(52) **U.S. Cl.** **D12/345**

(58) **Field of Classification Search** D12/317-319,
D12/322-324, 326, 343, 345, 400, 195, 183,
D12/418, 415, 190, 192; 114/78, 189; D25/52;
244/117 R, 119, 126, 129.1, 129.3; 296/200-201
See application file for complete search history.

(56) **References Cited**

U.S. PATENT DOCUMENTS

D244,018 S * 4/1977 Greiss et al. D12/195

D516,496 S * 3/2006 Guard et al. D12/345

D600,623 S * 9/2009 Fiedler et al. D12/345

D600,624 S * 9/2009 Fiedler et al. D12/345

D605,103 S * 12/2009 Schuephaus et al. D12/345

* cited by examiner

Primary Examiner—Ian Simmons

Assistant Examiner—Dana L Sipos

(74) *Attorney, Agent, or Firm*—Wood, Herron & Evans, L.L.P.

(57) **CLAIM**

The ornamental design for a ceiling lining panel for an aircraft cabin, as shown and described.

DESCRIPTION

FIG. 1 is a front elevation view of a ceiling lining panel for an aircraft cabin showing our new design; and,

FIG. 2 is a front perspective view thereof.

The evenly dashed broken lines in the drawings illustrate the portions of the design that form no part of the claim. The dot-dash broken lines in the drawings define the bounds of the claim and form no part thereof.

1 Claim, 2 Drawing Sheets

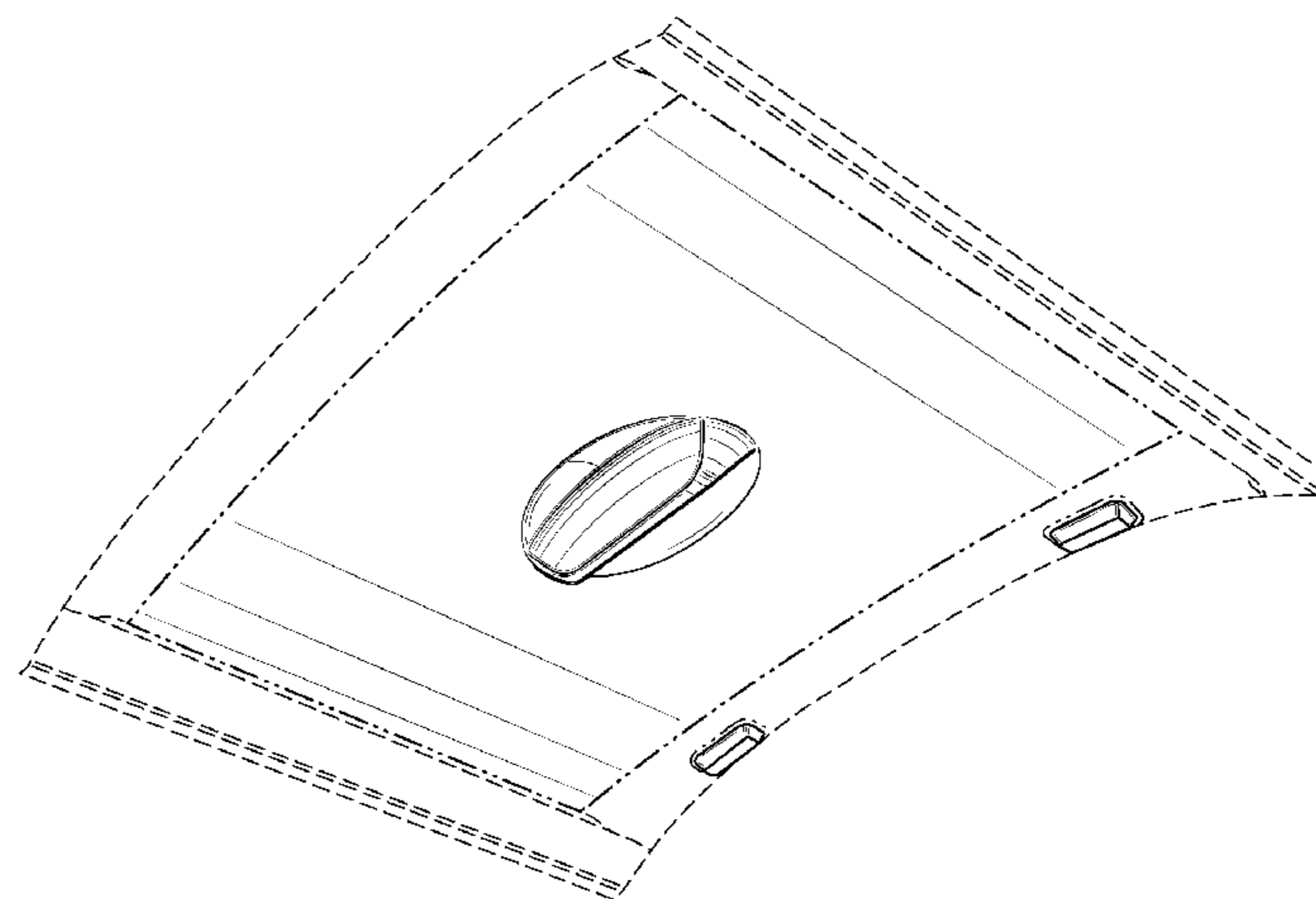
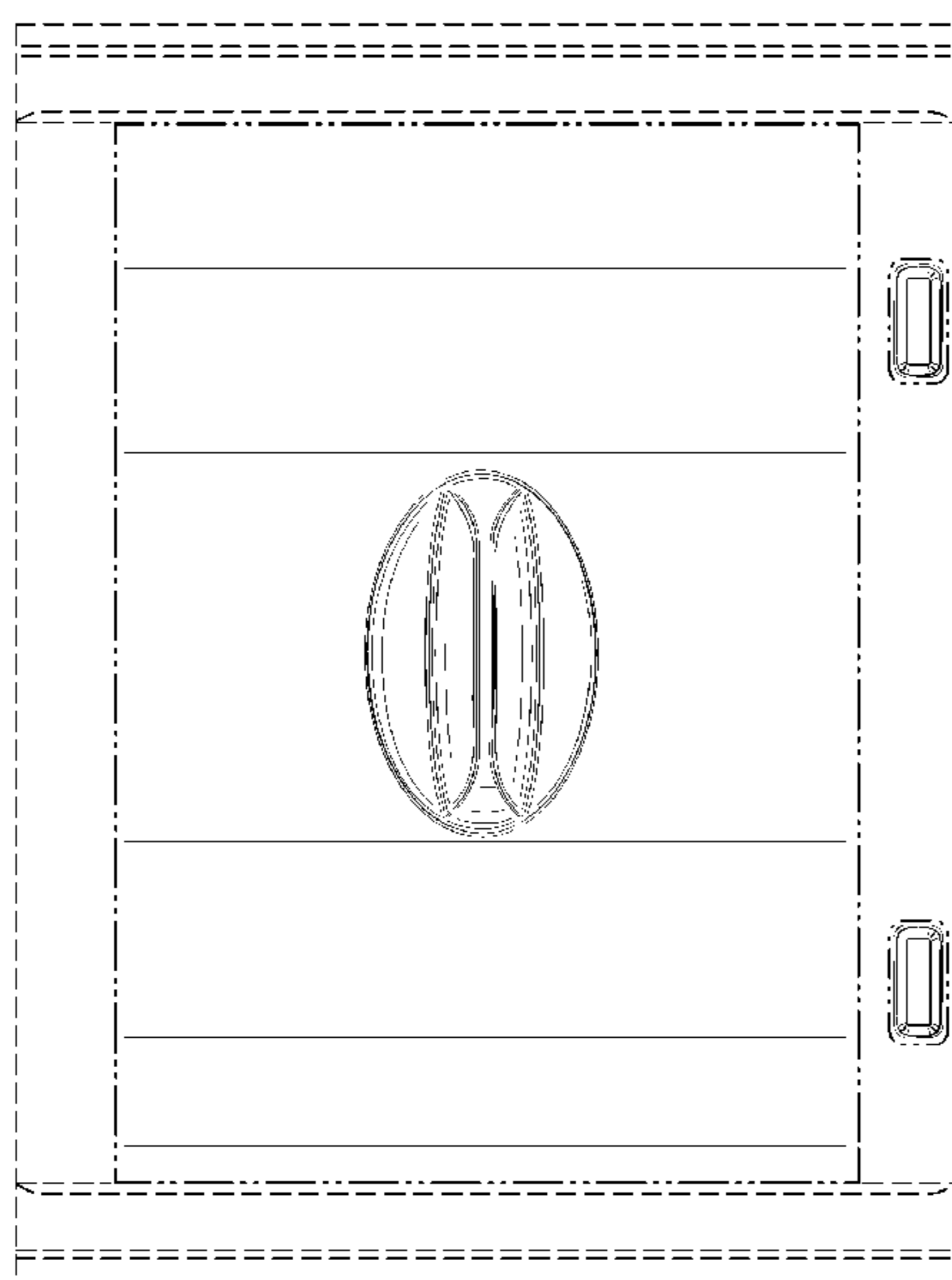

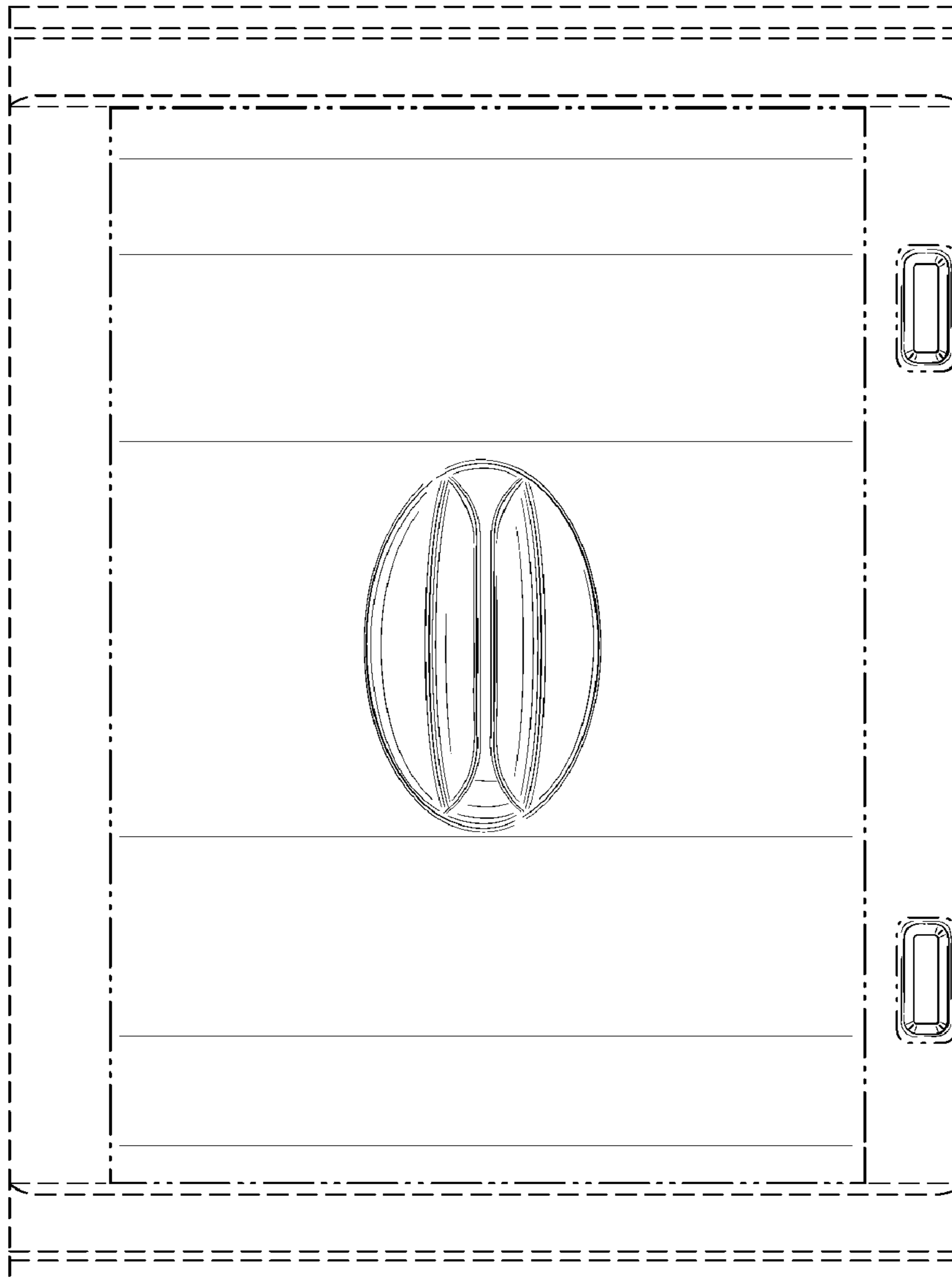

FIG. 1

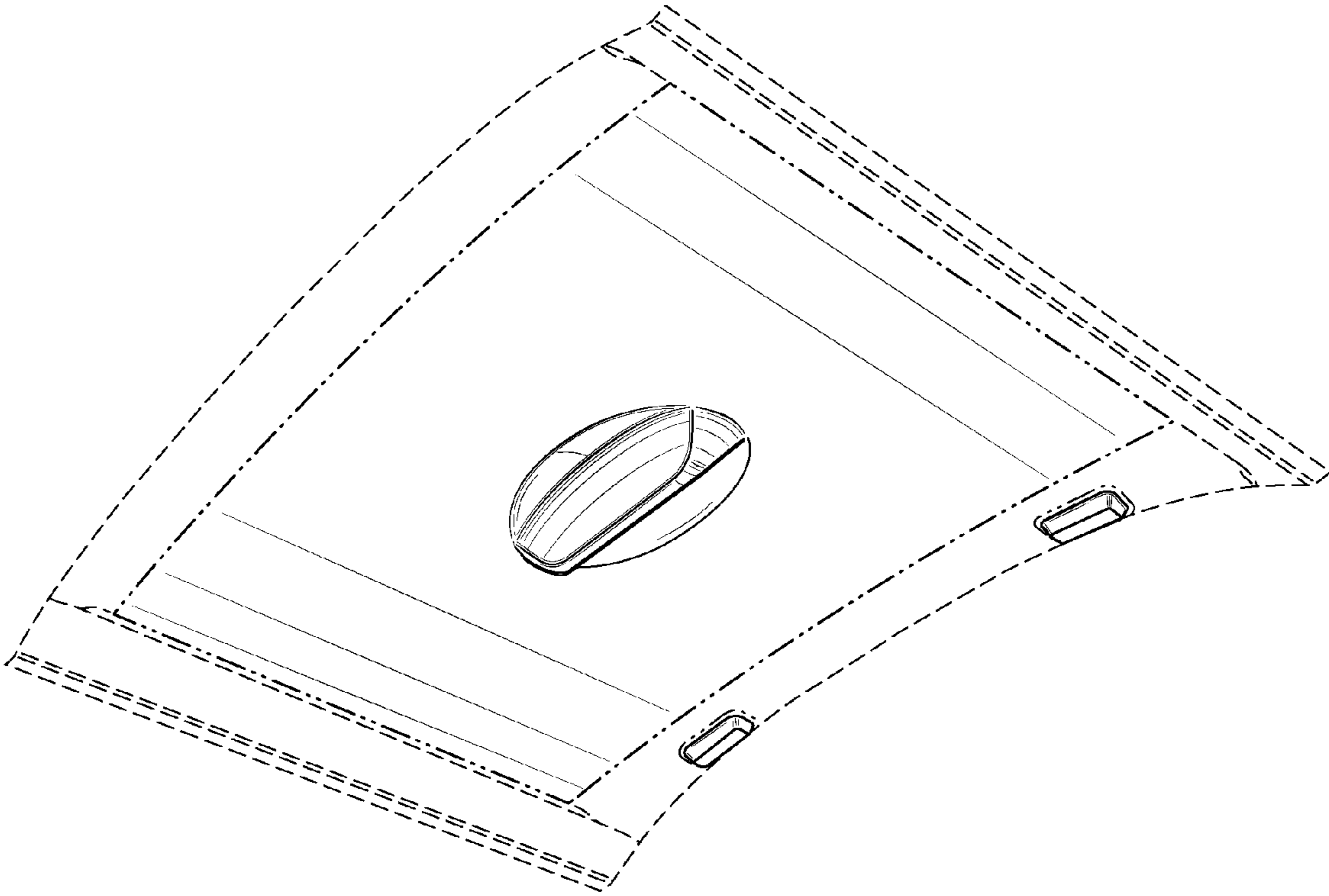

FIG. 2