

US00D624465S

(12) **United States Design Patent**  
**Noble et al.**

(10) **Patent No.:** **US D624,465 S**

(45) **Date of Patent:** **\*\* Sep. 28, 2010**

(54) **SUSPENSION ASSEMBLY**

(75) Inventors: **Shawn D. Noble**, Naperville, IL (US);  
**Michael P. Robinson**, Chicago, IL (US);  
**Ashley T. Dudding**, Yorkville, IL (US);  
**Michael Brannigan**, Narbeth, PA (US);  
**Christopher W. Forrest**, Auburn, IN (US)

(73) Assignee: **Henrickson USA, L.L.C.**, Itasca, IL (US)

(\*\*) Term: **14 Years**

(21) Appl. No.: **29/339,134**

(22) Filed: **Jun. 24, 2009**

(51) **LOC (9) Cl.** ..... **12-16**

(52) **U.S. Cl.** ..... **D12/159**

(58) **Field of Classification Search** ..... D12/118,  
D12/400, 161, 159, 160; 188/281, 298, 297,  
188/315, 316, 274, 286; 267/195, 136, 64.15,  
267/217; 464/173; D21/76; 293/134

See application file for complete search history.

(56) **References Cited**

**U.S. PATENT DOCUMENTS**

3,279,820 A 10/1966 Hickman  
6,659,438 B2 \* 12/2003 Michael et al. .... 267/294  
D610,952 S \* 3/2010 Noble et al. .... D12/159

**OTHER PUBLICATIONS**

Hendrickson, A Boler Company, Hendrickson Frame Hanger Selection Guide, May 1990.  
Hendrickson, A Boler Company, Hendrickson RS Series, Single Axle Suspension, Sep. 1995.  
Hendrickson, RS Series Rubber Load Cushion, Only Hendrickson makes choosing a heavy-duty suspension this easy, Jun. 1993.  
Hendrickson, A Boler Company, HN Series Technical Sales Publication, Jun. 1997.  
Hendrickson Suspension, RS Series rubber load cushion, Jul. 1991.  
Hendrickson Mfg., Tandem Division, Wide spread equalizing beams, sales bulletin, May 1981.

Hendrickson Mfg. Co., Tandem Division, Hendrickson Tandem Suspensions for GMC Trucks, Aug. 1979.  
Hendrickson, The Boler Company, RS Frame Hanger, Dec. 1997.  
Hendrickson, A Boler Company, RS Series Rubber Load Cushion Suspensions, Mar. 1996.  
Hendrickson, A Boler Company, RS Series Rubber Load Cushion Suspensions, Jul. 1996.  
Hendrickson, A Boler Company, RS Series Rubber Load Cushion, Mar. 1998.  
Hendrickson Suspension, HN Series Premium Rubber, Hendrickson introduces a completely new concept in Walking Beam Suspension, Jun. 1993.  
Hendrickson Suspension, A Boler Company, Hendrickson HNT Series, Feb. 1992.  
Hendrickson Suspension, Sales Engineering Update, Mar. 1993.  
Hendrickson Truck Suspension Systems, A Boler Company, RS Series Rubber Load Cushion, Dec. 1996.  
Hendrickson Truck Suspension Systems, A Boler Company, RS Series Rubber Load Cushion, Apr. 1998.  
Hendrickson Truck Suspension Systems, A Boler Company, HN Series VariRate Spring System, May 1997.  
Hendrickson Truck Suspension Systems, A Boler Company, HN Series VariRate Spring System, Nov. 1997.  
Hendrickson Truck Suspension Systems, A Boler Company, HN Series VariRate Spring System, Sep. 1998.  
Hendrickson Truck Suspension Systems, A Boler Company, HN Series VariRate Spring System, Jul. 1999.  
Hendrickson, HN Series VariRate Spring System, Nov. 2000.  
Hendrickson, HN Series VariRate Spring System, Nov. 2005.  
Hendrickson Truck Suspension Systems, A Boler Company, HN 402, Feb. 1996.  
Hendrickson Truck Suspension Systems, A Boler Company, R Series Solid Mount, Jul. 1999.  
Hendrickson Truck Suspension Systems, A Boler Company, RS Series Rubber Load Cushion, Jun. 1999.  
Hendrickson, Haulmaax Heavy Duty Suspension, Oct. 2001.  
Hendrickson, Haulmaax Heavy Duty Suspension, Dec. 2003.  
Hendrickson, Haulmaax Heavy Duty Suspension, Mar. 2005.  
Hendrickson, Haulmaax Heavy Duty Suspension, Jan. 2007.  
Hendrickson, Haulmaax Heavy Duty Suspension, Mar. 2008.  
Hendrickson, Assembly Instructions Haulmaax, Subject: Kit Nos. 64178-003 & 004, Feb. 2003.  
Hendrickson, Assembly Instructions Haulmaax, Subject: Tie-bar Bolster Spring Kit Nos. 64179-037, Jun. 2006.  
Hendrickson, Assembly Instructions Haulmaax, Subject: Outboard Frame Bracket for Paccar Vehicles Built after May 1, 2005 through Aug. 31, 2006, Oct. 2006.  
Hendrickson, Assembly Instructions Haulmaax Saddle Assembly, Subject: Service Kit No. 57974-048, Dec. 2008.

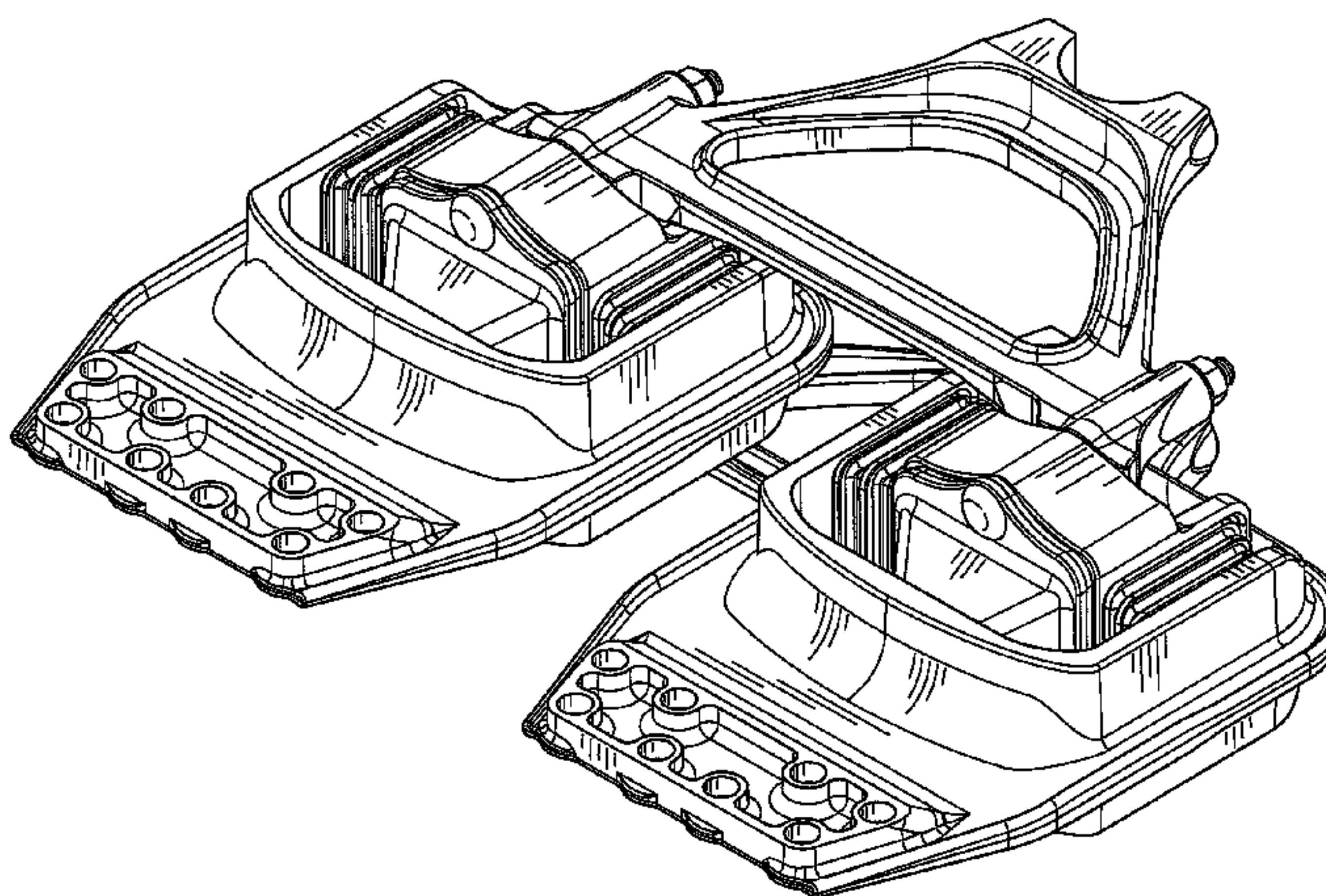
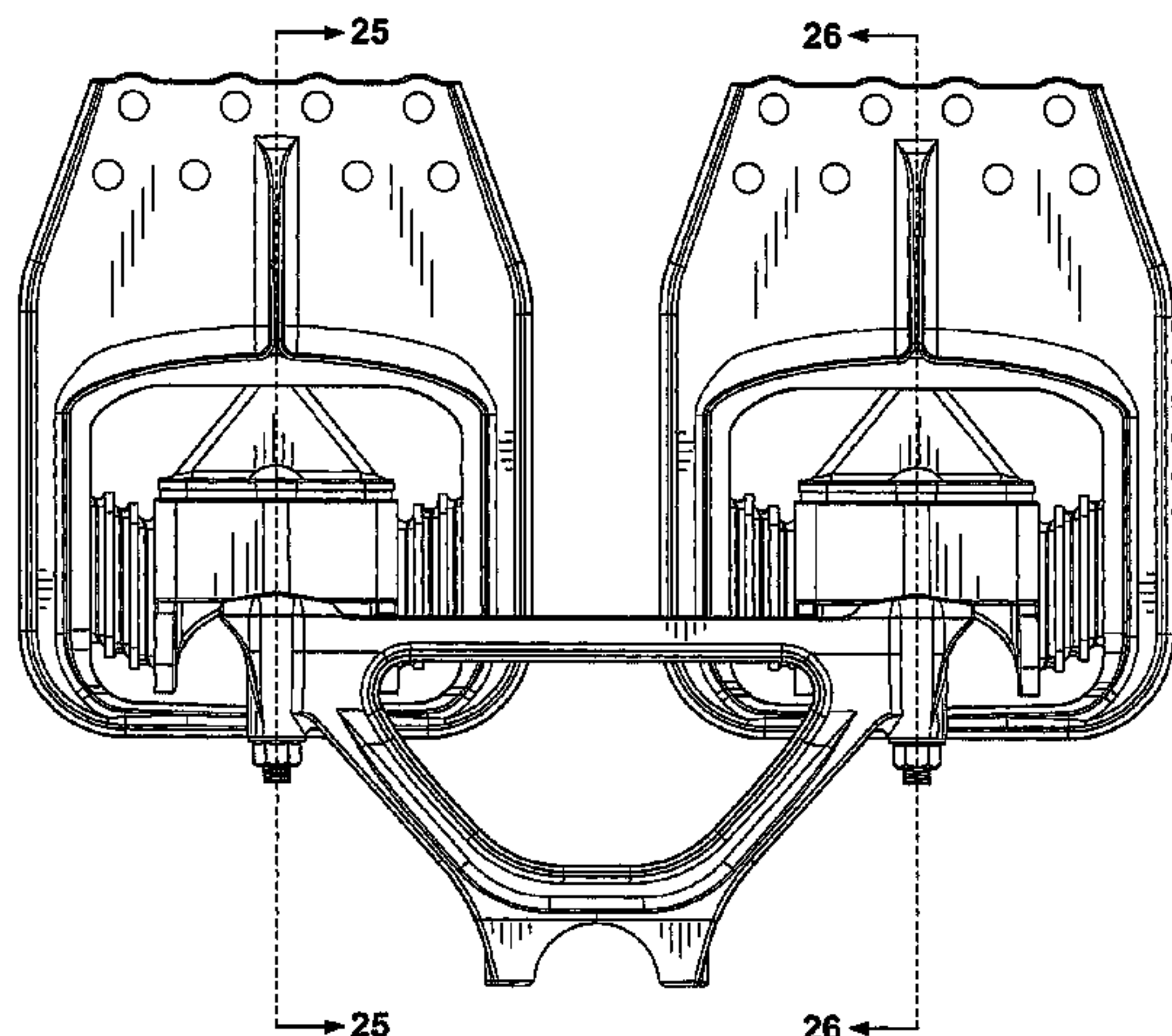



Hendrickson, Technical Bulletin HN 402/462/522, Subject: Auxiliary Spring Shim Design, Oct. 2000.  
 Hendrickson, Technical Bulletin HN 402/462/522, Subject: Auxiliary Spring Shim Design, Dec. 2000.  
 Hendrickson, Technical Bulletin HN 402/462/522, Subject: Auxiliary Spring Shim Design, Jun. 2006.  
 Hendrickson, Technical Bulletin Haulmaax Series, Subject: Mandatory Shock Applications, Nov. 2004.  
 Hendrickson, Technical Bulletin R, RS, RT/RTE 46K Capacity, Subject: 46K Heavy-Duty Beam Option, Dec. 2004.  
 Hendrickson, Technical Bulletin Haulmaax, Subject: 54" Equalizing Beam Assembly, Oct. 2005.  
 Hendrickson, Technical Bulletin Haulmaax 460, Subject: Bolster Spring Assembly with Tie-bar, Jun. 2006.  
 Hendrickson Truck Suspension Systems, A Boler Company, Sales engineering update, Subject: HN-402/462 Auxiliary Spring Assembly, Aug. 1998.  
 Hendrickson Truck Suspension Systems, A Boler Company, Sales engineering update, Subject: Model Designation and Discontinuation, Aug. 1999.  
 Hendrickson Truck Suspension Systems, A Boler Company, Sales engineering update, Subject: Equalizer Beam, Aug. 1999.  
 Hendrickson, Parts List RS Series, Nov. 2004.  
 Hendrickson, Parts List Haulmaax, May 2002.  
 Hendrickson, Parts List Haulmaax, Jul. 2003.  
 Hendrickson, Parts List Haulmaax, Jul. 2006.  
 Hendrickson, Parts List Haulmaax, Dec. 2007.  
 Hendrickson, Parts List RS 400/460/480/520 Jan. 1998.  
 Hendrickson, Parts List HN 402/462, Sep. 1997.  
 Hendrickson, Parts List HN Series, Dec. 2004.  
 Hendrickson Truck Suspension Systems, A Boler Company, Technical Publication RS-340 thru 520, Subject: Springing: Frame Hangers, Load Cushions and Saddle Assembly, Jul. 1993.  
 Hendrickson Truck Suspension Systems, A Boler Company, Technical Publication HN Series Truck & Trailer Suspension No: 17730-198, Mar. 1993.  
 Hendrickson, Technical Procedure HN/HNT-400/460 Truck & Trailer Suspension in Production Nov. 1988-Sep. 1996, Apr. 1998.  
 Hendrickson Truck Suspension Systems, A Boler Company, Technical Publication HN 402 Series, Subject: Service Instructions, Aug. 1996.  
 Hendrickson Truck Suspension Systems, A Boler Company, Technical Publication HN 402/462 Series, Subject: Service Instructions, Aug. 1998.  
 Hendrickson, Technical Procedure Haulmaax, Subject: Service Instructions, May 2002.  
 Hendrickson, Technical Procedure Haulmaax, Subject: Service Instructions, Jun. 2007.  
 Hendrickson, Technical Procedure Haulmaax, Subject: Pre-delivery Inspection and Preventive Maintenance, Apr. 2006.  
 Hendrickson, Technical Procedure Haulmaax, Subject: Service Instructions, Dec. 2007.  
 Hendrickson, Technical Procedure R/RS/RT Heavy Duty, Subject: 650K/850K/1000K Pound Capacity Beam End Connection Tightening Torque Procedure, Jul. 2006.  
 Hendrickson, RS Series Rubber Load Cushion, Feb. 2000.  
 MOR/ryde, The MOR/ryde Steer and Drive Axle Suspension Systems, Mar. 7, 2008.  
 MOR/ryde, Company Profile, downloaded from the World Wide Web at <http://www.morrydede.com/php/about/profile/php> on Feb. 28, 2008.  
 MOR/ryde, T/A Modular Rubber Suspension System, Service Manual, Mar. 5, 2003.  
 MOR/ryde, Tandem Axle Rubber Suspension Sytem, Service Manual, Suspension Codes: T01-01 and L01-01, Mar. 5, 2003.  
 MOR/ryde, RL Rubber Leaf Suspension System, Owner's Manual, Mar. 12, 2003.  
 MOR/ryde, Commercial Trailer Suspension, Jun. 1973.  
 MOR/ryde, School Bus Suspension, Aug. 1973.  
 MOR/ryde, a rubber spring . . . heart of the Mor/ryde system, Aug. 1973.  
 Jorn, Technology in Rubber—Metal, Sep. 29, 2008.  
 Hendrickson, Parts List RS Series, Apr. 2008.

Hendrickson, Technical Procedure, R/RS Heavy Duty, Subject: 85K/100K/120K lbs Capacity Tightening Torque for Torque Rod and Saddle Assembly Fasteners, Oct. 2008.  
 U.S. Appl. No. 12/334,195, entitled "Modular Suspension System and Components Thereof" and filed Dec. 12, 2008.  
 U.S. Appl. No. 12/045,069, entitled "Elastomeric Spring Vehicle Suspension" and filed Mar. 10, 2008.  
 U.S. Appl. No. 29/329,354, entitled "Suspension Assembly" and filed Dec. 12, 2008.  
 U.S. Appl. No. 29/339,132, entitled "Spring Housing" and filed Jun. 24, 2009.  
 Hendrickson, HN FR Series, HN FR Suspension 42-58K Fire/Rescue, Feb. 2009.  
 Hendrickson, Haulmaax Heavy-Duty Suspension, Jan. 2009.  
 Kenworth Truck Company, Haulmaax, May 14, 2009.  
 U.S. Appl. No. 29/329,357 entitled "Spring Housing for a Suspension" and filed Dec. 12, 2008.  
 U.S. Appl. No. 29/339,128 entitled "Spring Mount" and filed Jun. 24, 2009.  
 U.S. Appl. No. 29/337,977 entitled "Spring Mount for a Suspension" and filed Jun. 2, 2009.  
 U.S. Appl. No. 29/337,974 entitled "Progressive Rate Spring for a Suspension" and filed Jun. 2, 2009.  
 U.S. Appl. No. 29/337,985 entitled "Spring Housing for a Suspension" and filed Jun. 2, 2009.  
 U.S. Appl. No. 29/337,973 entitled "Saddle for a Suspension" and filed Jun. 2, 2009.  
 U.S. Appl. No. 29/315,182 entitled "Suspension Assembly" and filed Jun. 2, 2009.  
 U.S. Appl. No. 29/329,338 entitled "Shear Spring for a Suspension" and filed Dec. 12, 2008.  
 U.S. Appl. No. 29/329,343 entitled "Saddle for a Suspension" and filed Dec. 12, 2008.  
 U.S. Appl. No. 29/329,359 entitled "Progressive Rate Spring for a Suspension" and filed December 12, 2008.

\* cited by examiner

*Primary Examiner*—T. Chase Nelson  
*Assistant Examiner*—Michael A Pratt  
 (74) *Attorney, Agent, or Firm*—McDonnell Boehnen Hulbert & Berghoff LLP

(57) **CLAIM**

The ornamental design for a suspension assembly, as shown and described.

**DESCRIPTION**

FIG. 1 is an elevational view showing a front side of a suspension assembly having the inventive design, and FIG. 1 includes section lines 25—25 and 26—26;

FIG. 2 is a bottom view of the suspension assembly shown in FIG. 1;

FIG. 3 is an elevational view showing the left side of the suspension assembly shown in FIG. 1, and FIG. 3 includes section lines 19—19, 20—20, and 21—21;

FIG. 4 is an elevational view showing the right side of the suspension assembly shown in FIG. 1, and FIG. 4 includes section lines 17—17, 18—18, and 22—22;

FIG. 5 is a top view of the suspension assembly shown in FIG. 1;

FIG. 6 is an elevational view showing the back side of the suspension assembly shown in FIG. 1, and FIG. 6 includes section lines 10—10, 11—11, 12—12, 13—13, 14—14, 15—15, 16—16, 23—23, 24—24, 27—27, 28—28, 29—29, 30—30, 31—31, and 32—32;



FIG. 7 is a perspective view showing the top, back side, and right side of the suspension assembly shown in FIG. 1;

FIG. 8 is a perspective view showing the top, front side, and left side of the suspension assembly shown in FIG. 1;

FIG. 9 is another perspective view showing the top, back side, and right side of the suspension assembly shown in FIG. 1;

FIG. 10 is a sectional view of the suspension assembly shown in FIG. 6, taken along section lines 10—10 thereof;

FIG. 11 is a sectional view of the suspension assembly shown in FIG. 6, taken along section lines 11—11 thereof;

FIG. 12 is a sectional view of the suspension assembly shown in FIG. 6, taken along section lines 12—12 thereof;

FIG. 13 is a sectional view of the suspension assembly shown in FIG. 6, taken along section lines 13—13 thereof;

FIG. 14 is a sectional view of the suspension assembly shown in FIG. 6, taken along section lines 14—14 thereof;

FIG. 15 is a sectional view of the suspension assembly shown in FIG. 6, taken along section lines 15—15 thereof;

FIG. 16 is a sectional view of the suspension assembly shown in FIG. 6, taken along section lines 16—16 thereof;

FIG. 17 is a sectional view of the suspension assembly shown in FIG. 4, taken along section lines 17—17 thereof;

FIG. 18 is a sectional view of the suspension assembly shown in FIG. 4, taken along section lines 18—18 thereof;

FIG. 19 is a sectional view of the suspension assembly shown in FIG. 3, taken along section lines 19—19 thereof;

FIG. 20 is a sectional view of the suspension assembly shown in FIG. 3, taken along section lines 20—20 thereof;

FIG. 21 is a sectional view of the suspension assembly shown in FIG. 3, taken along section lines 21—21 thereof;

FIG. 22 is a sectional view of the suspension assembly shown in FIG. 4, taken along section lines 22—22 thereof;

FIG. 23 is a sectional view of the suspension assembly shown in FIG. 6, taken along section lines 23—23 thereof;

FIG. 24 is a sectional view of the suspension assembly shown in FIG. 6, taken along section lines 24—24 thereof;

FIG. 25 is a sectional view of the suspension assembly shown in FIG. 1, taken along section lines 25—25 thereof;

FIG. 26 is a sectional view of the suspension assembly shown in FIG. 1, taken along section lines 26—26 thereof;

FIG. 27 is a sectional view of the suspension assembly shown in FIG. 6, taken along section lines 27—27 thereof;

FIG. 28 is a sectional view of the suspension assembly shown in FIG. 6, taken along section lines 28—28 thereof;

FIG. 29 is a sectional view of the suspension assembly shown in FIG. 6, taken along section lines 29—29 thereof;

FIG. 30 is a sectional view of the suspension assembly shown in FIG. 6, taken along section lines 30—30 thereof;

FIG. 31 is a sectional view of the suspension assembly shown in FIG. 6, taken along section lines 31—31 thereof; and,

FIG. 32 is a sectional view of the suspension assembly shown in FIG. 6, taken along section lines 32—32 thereof.

The section lines shown in FIG. 1, FIG. 3, FIG. 4, and FIG. 6 form no part of the claimed design.

**1 Claim, 17 Drawing Sheets**

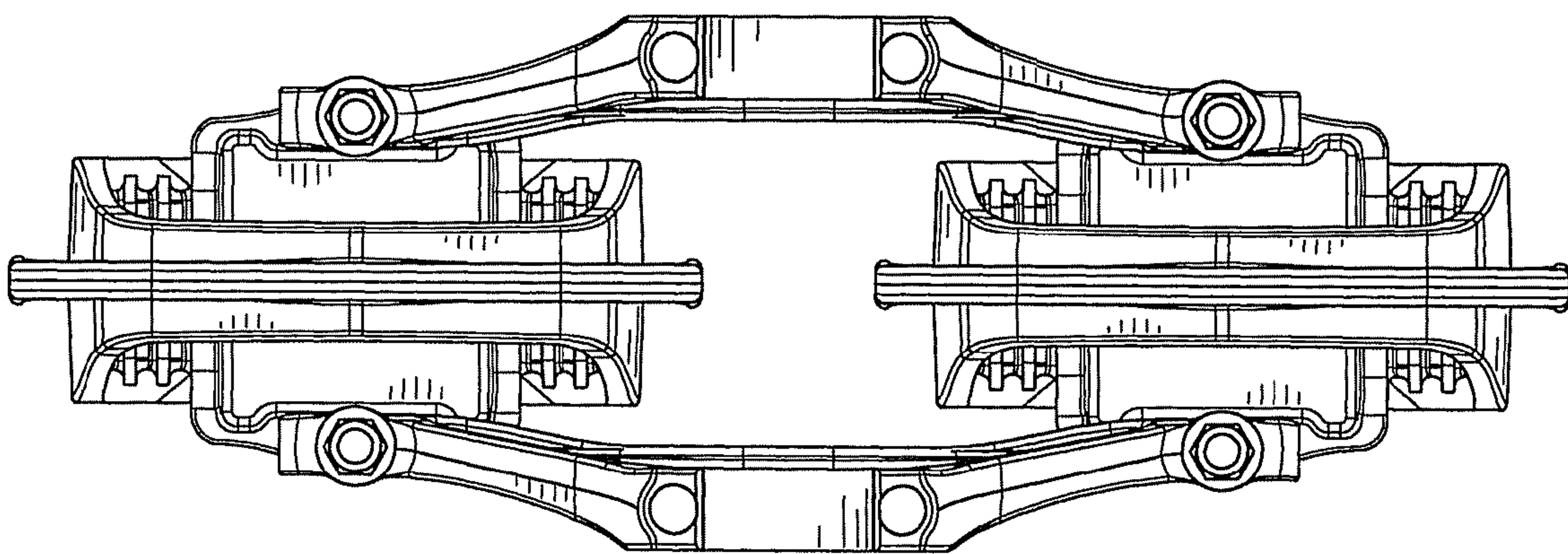
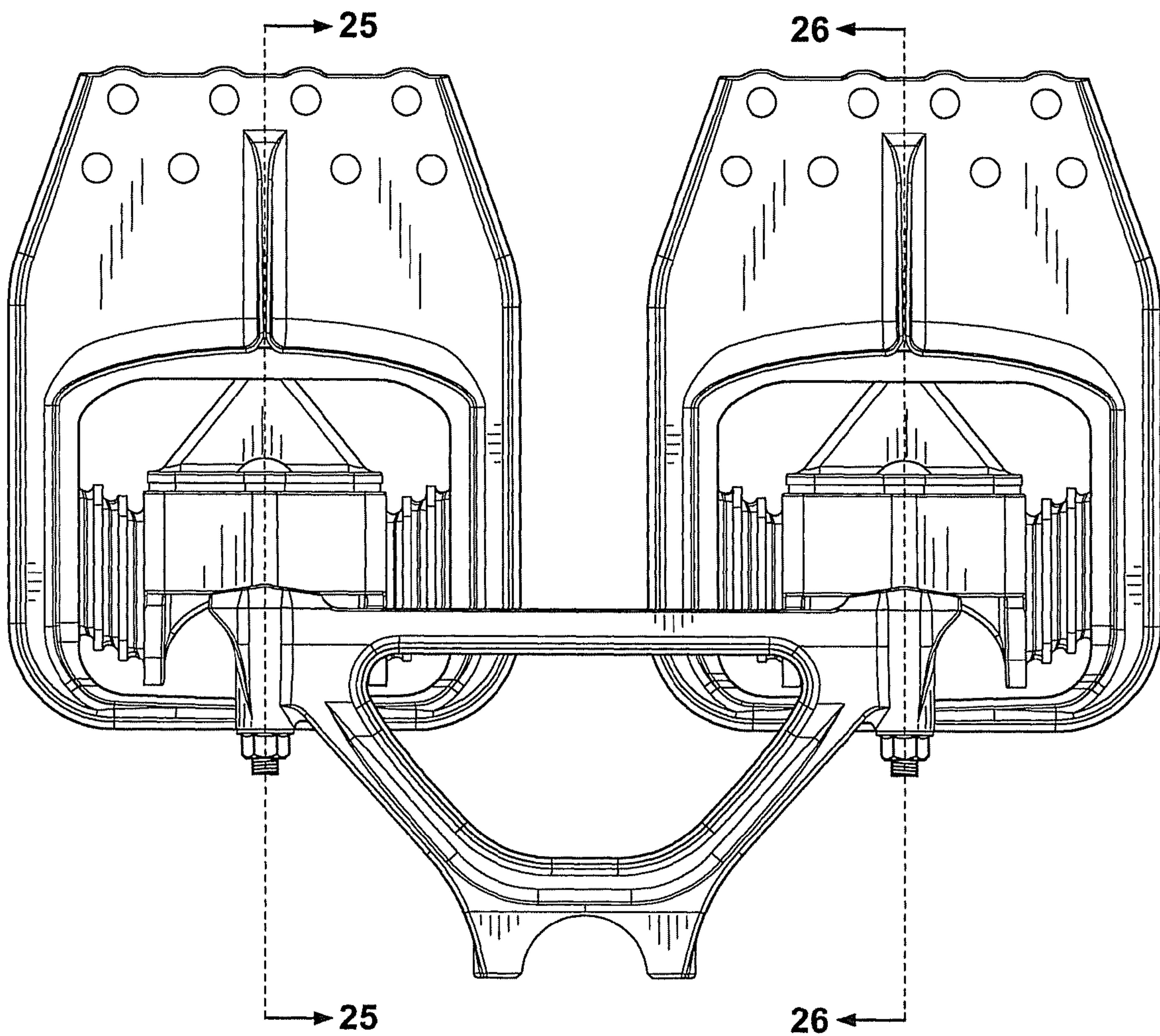



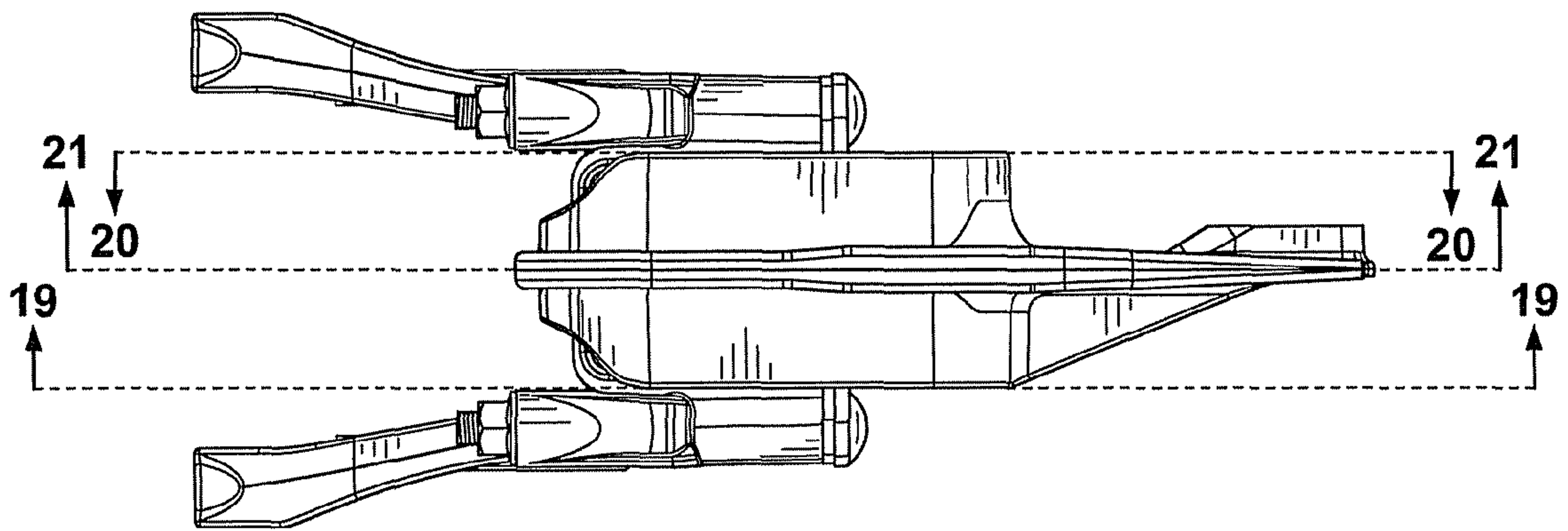

FIG. 3

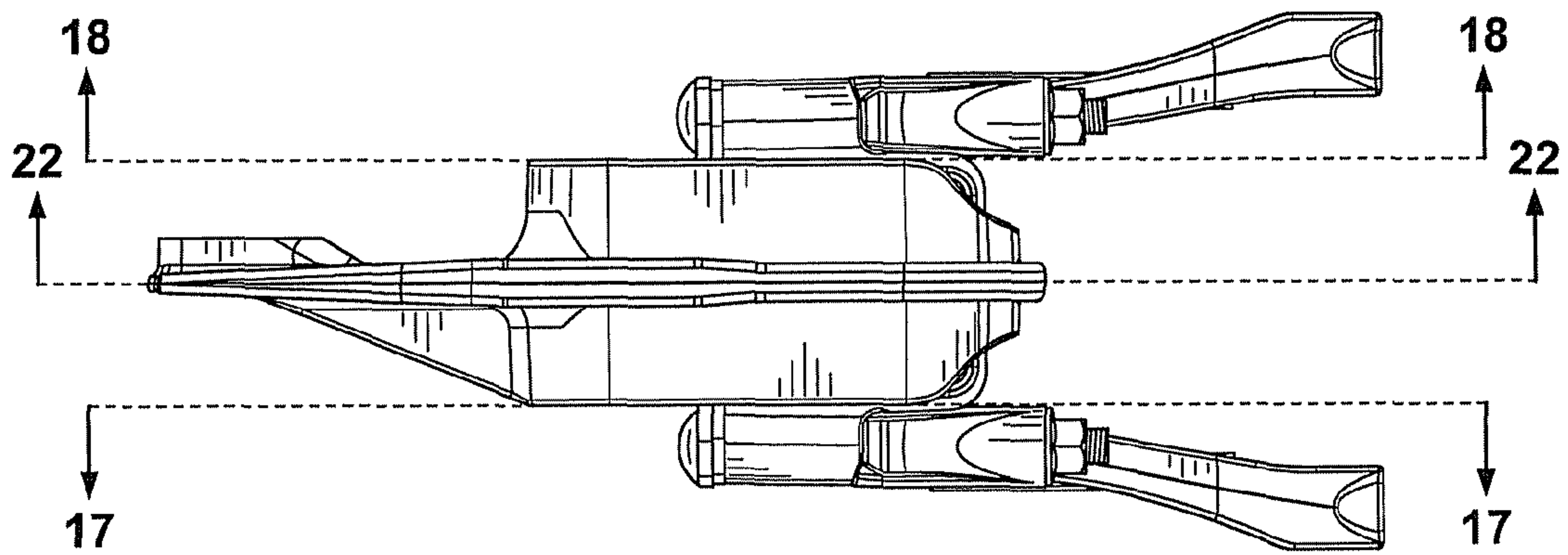

FIG. 4

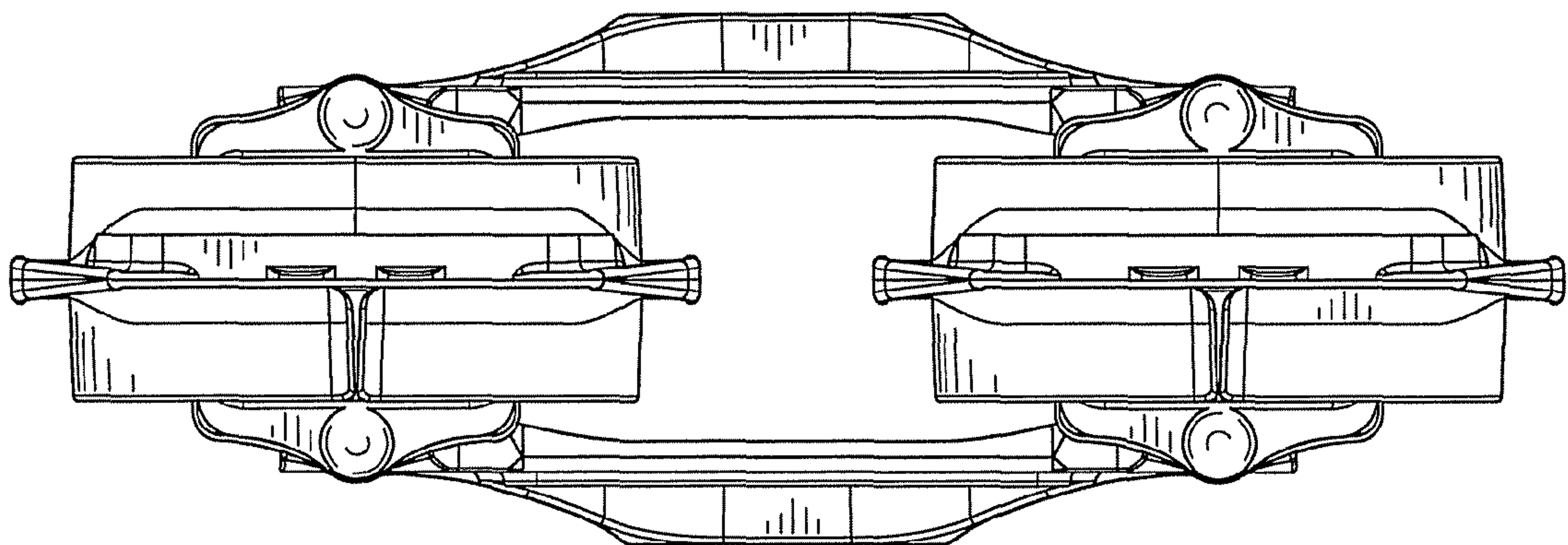

FIG. 5

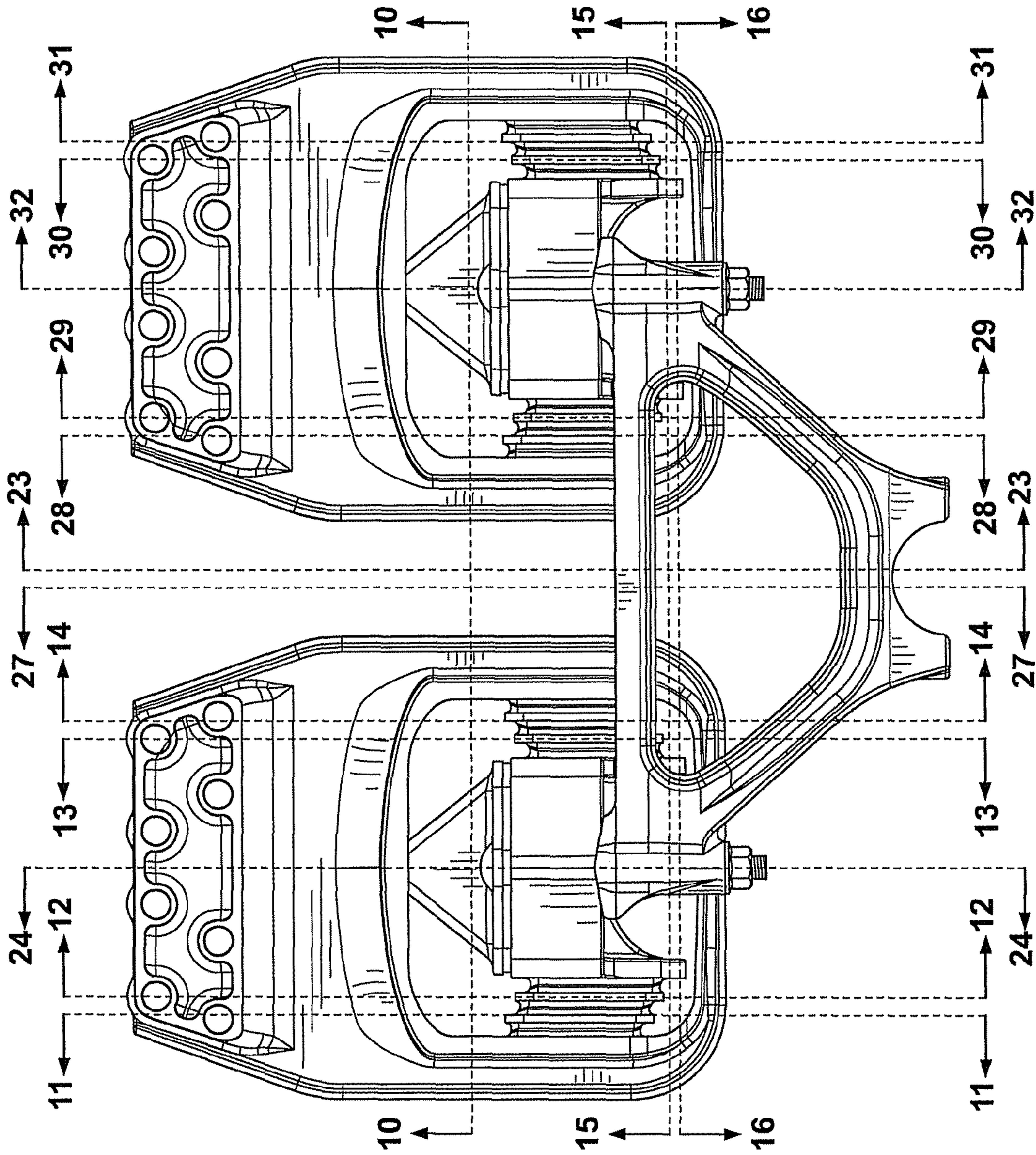

FIG. 6



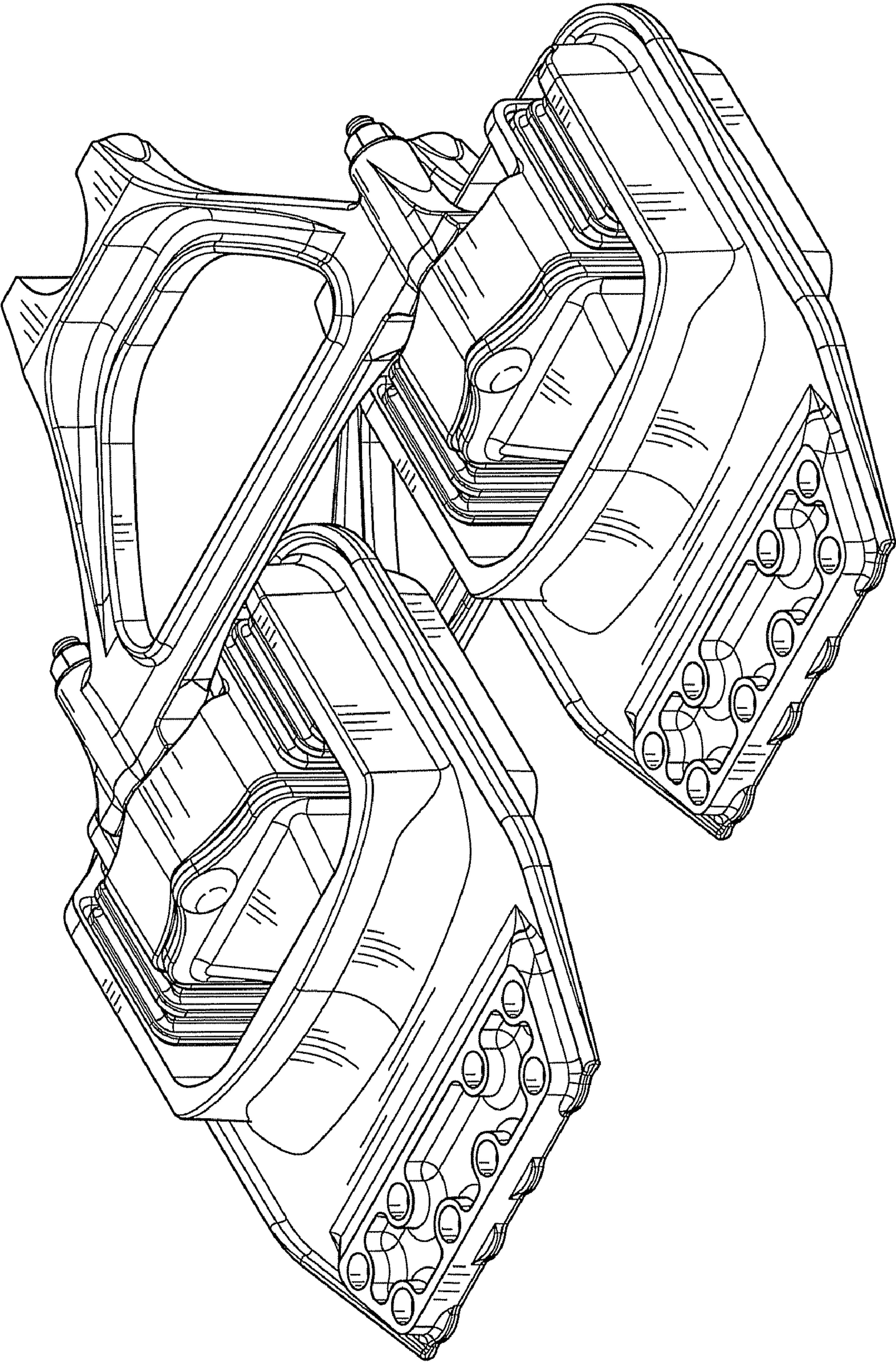

FIG. 7



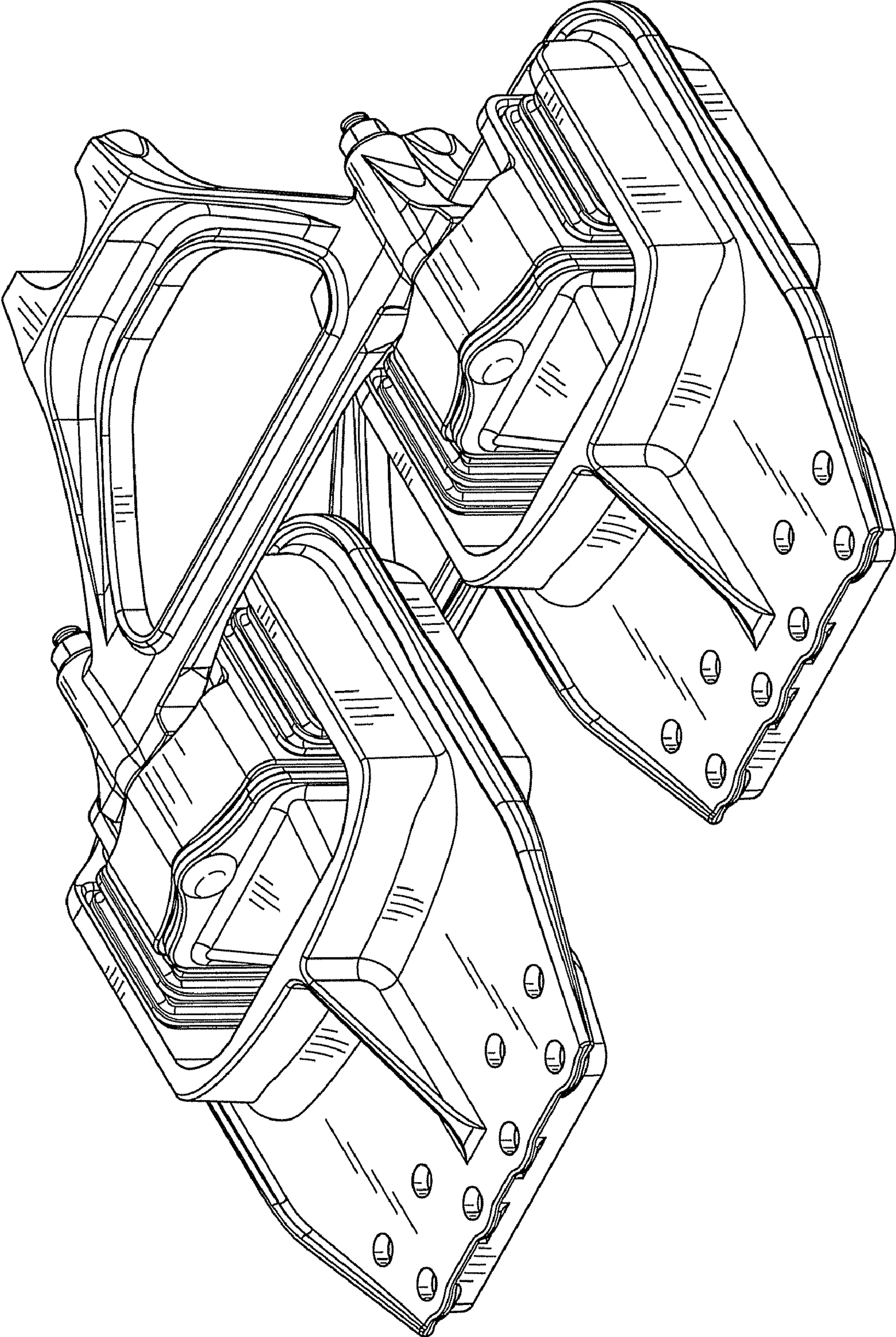

FIG. 8



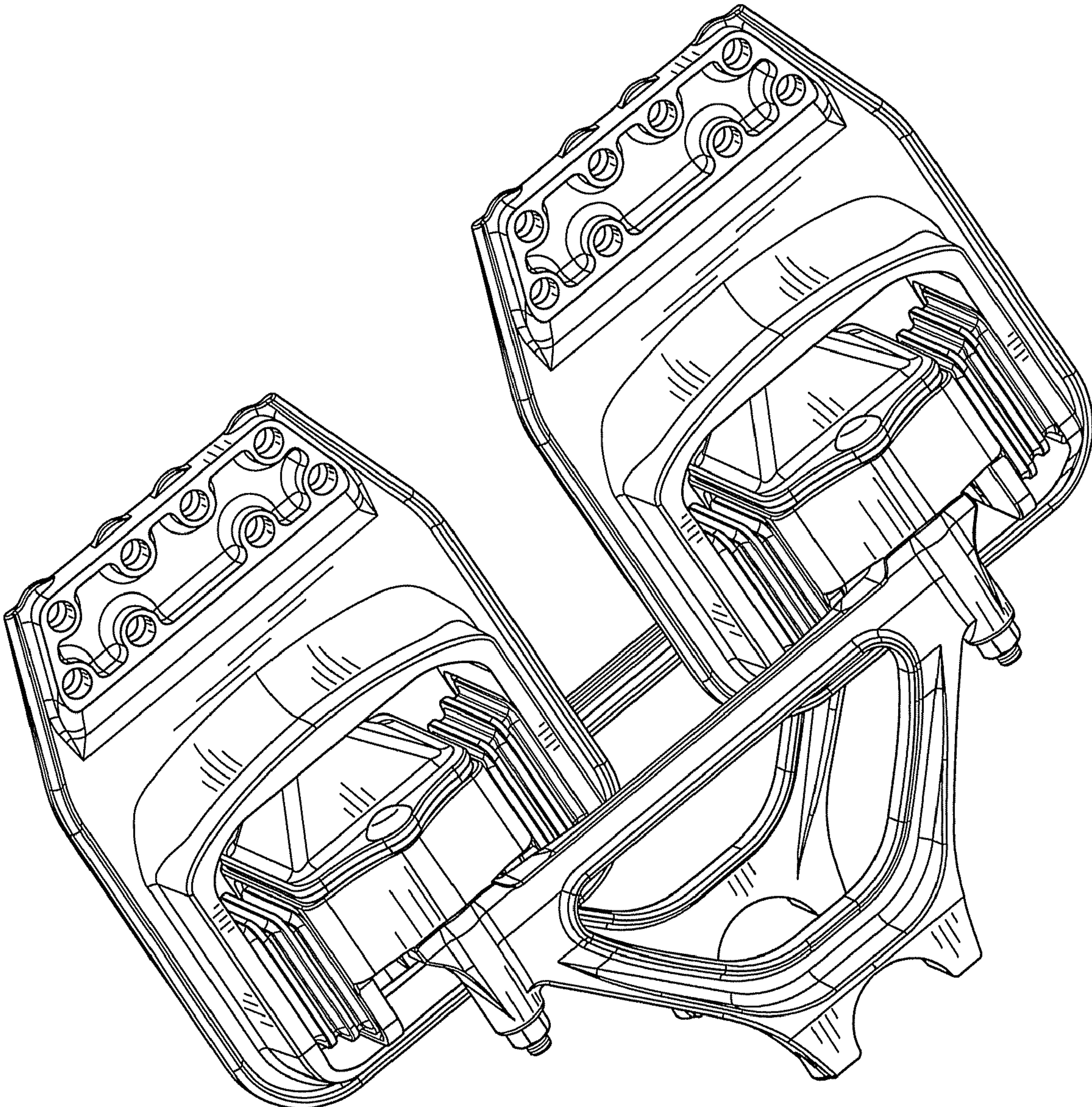

FIG. 9

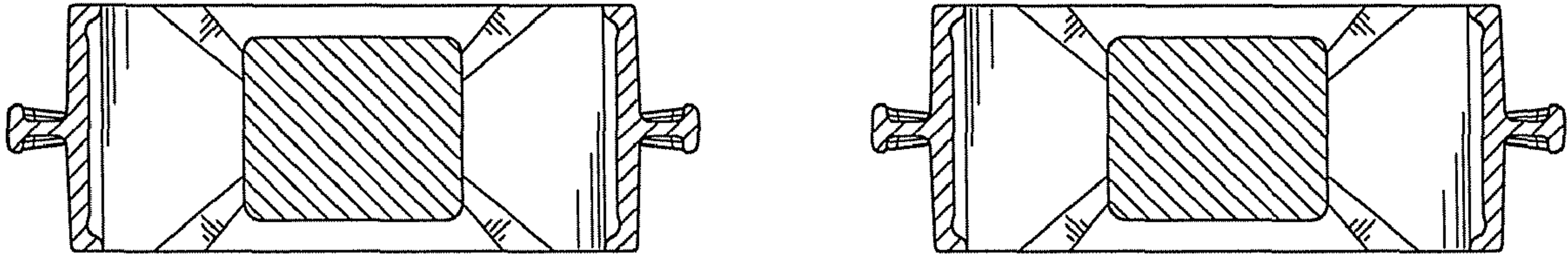

FIG. 10

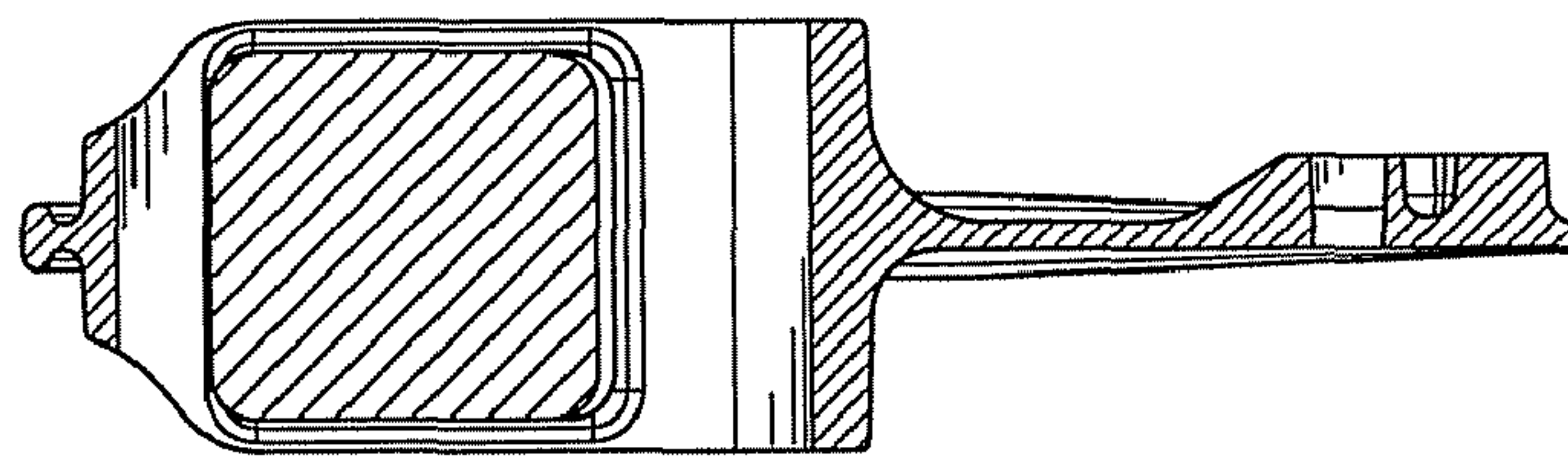

FIG. 11

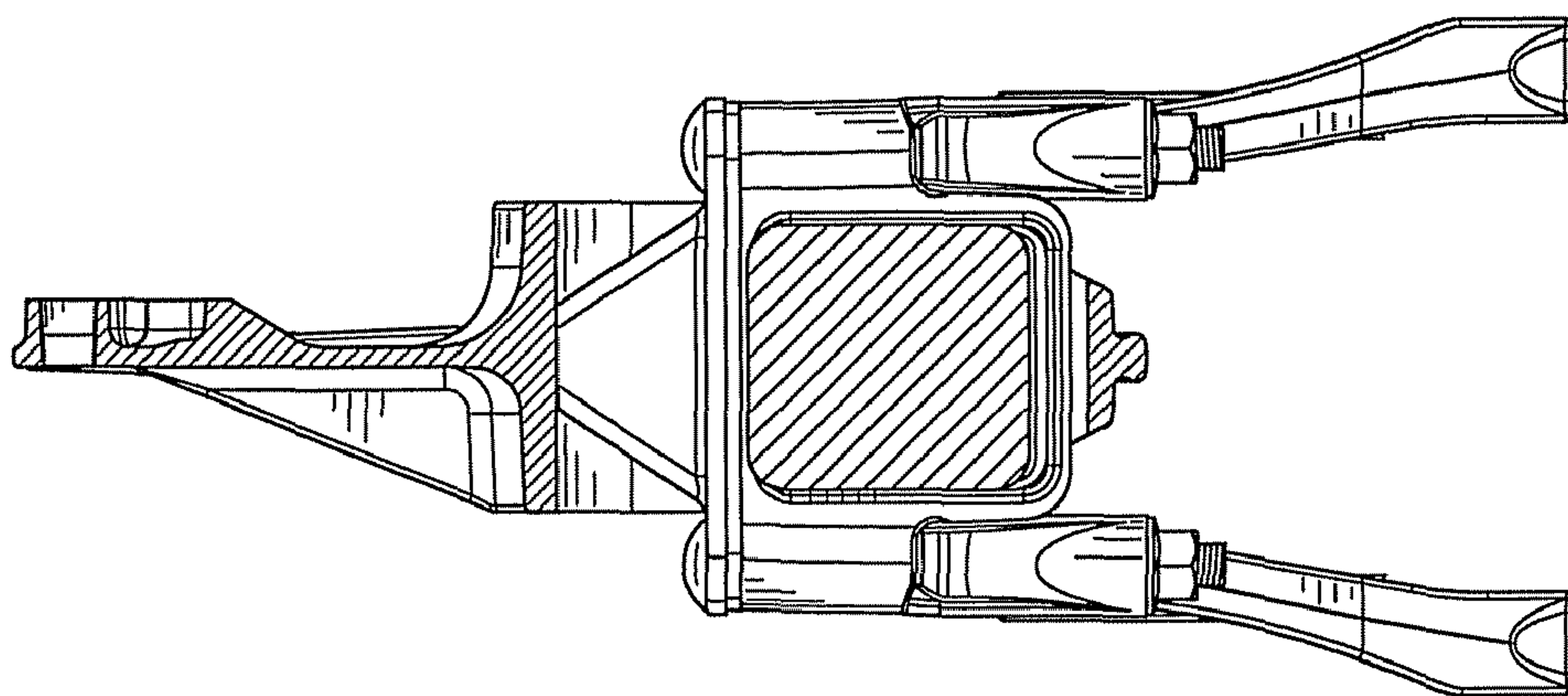

FIG. 12



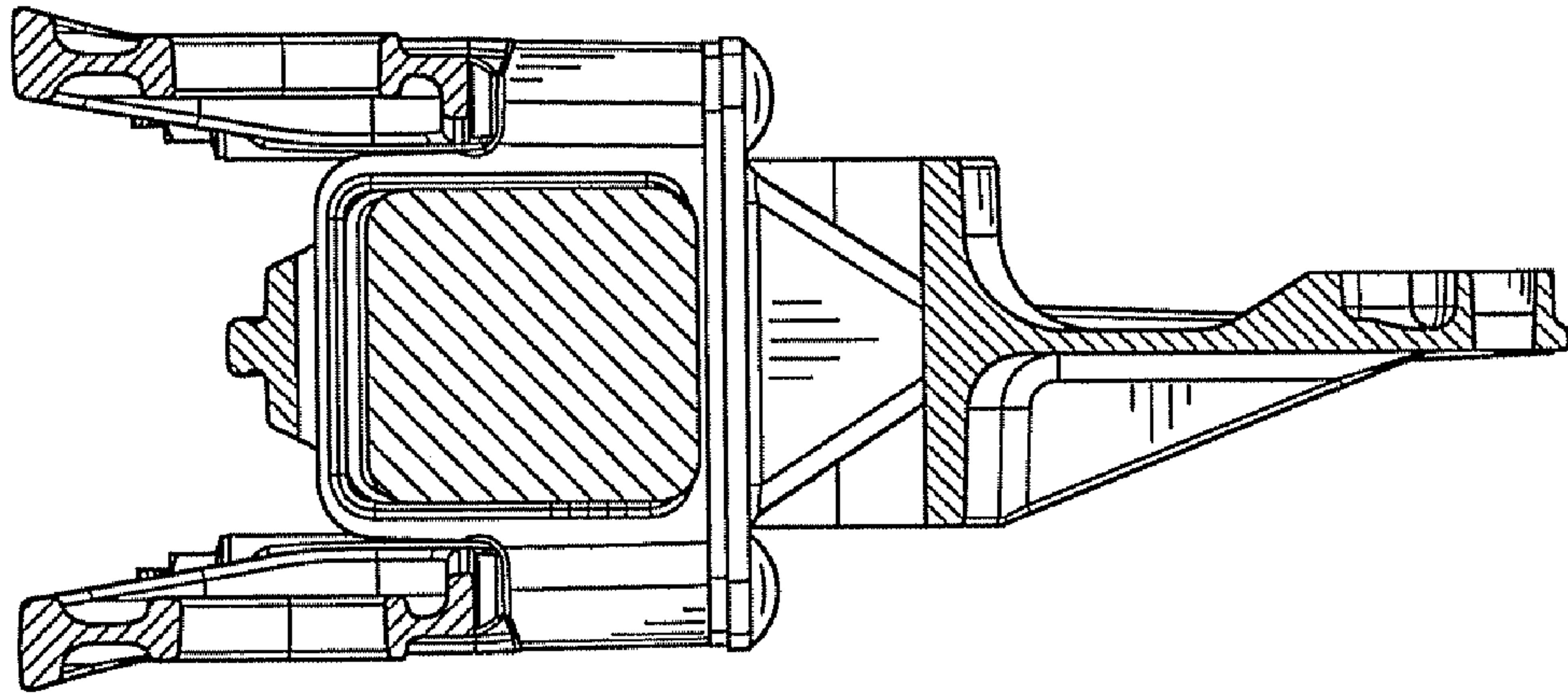

FIG. 13

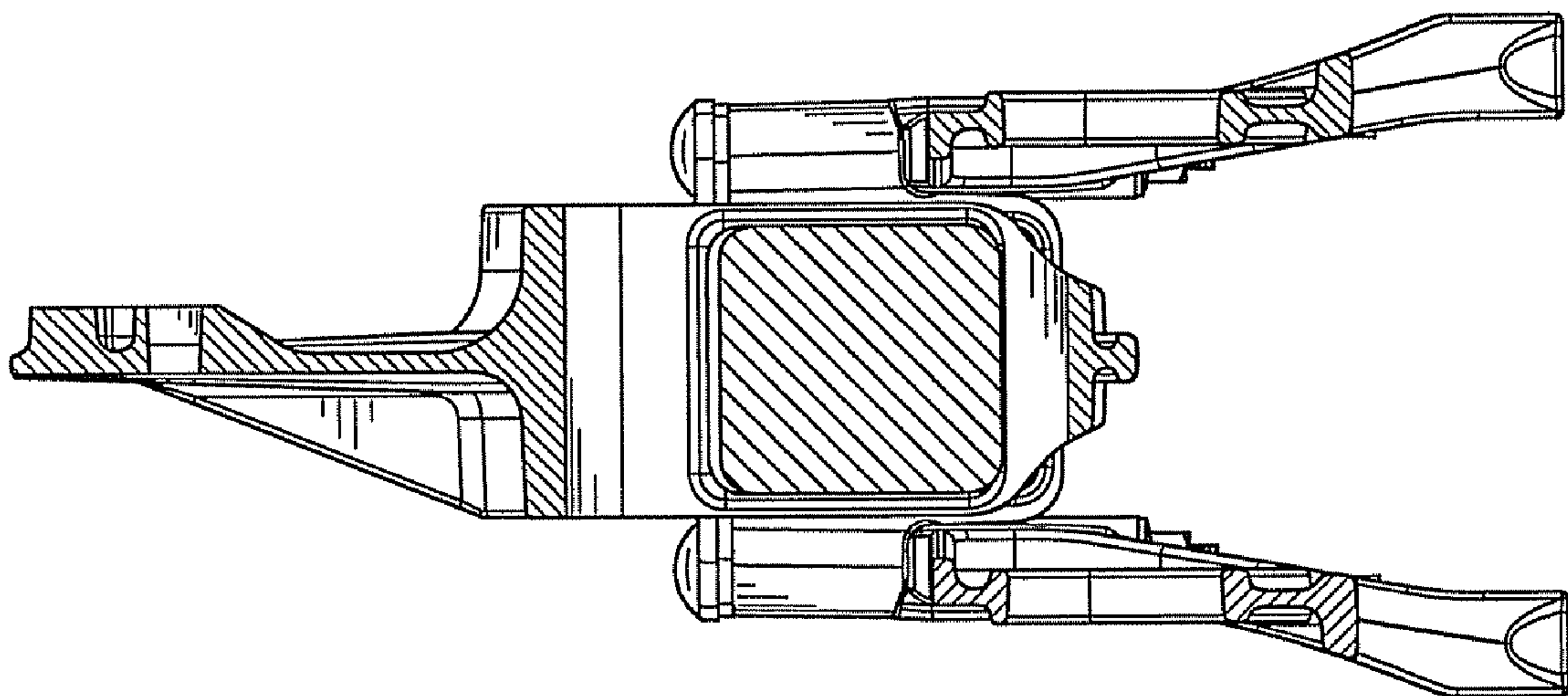

FIG. 14

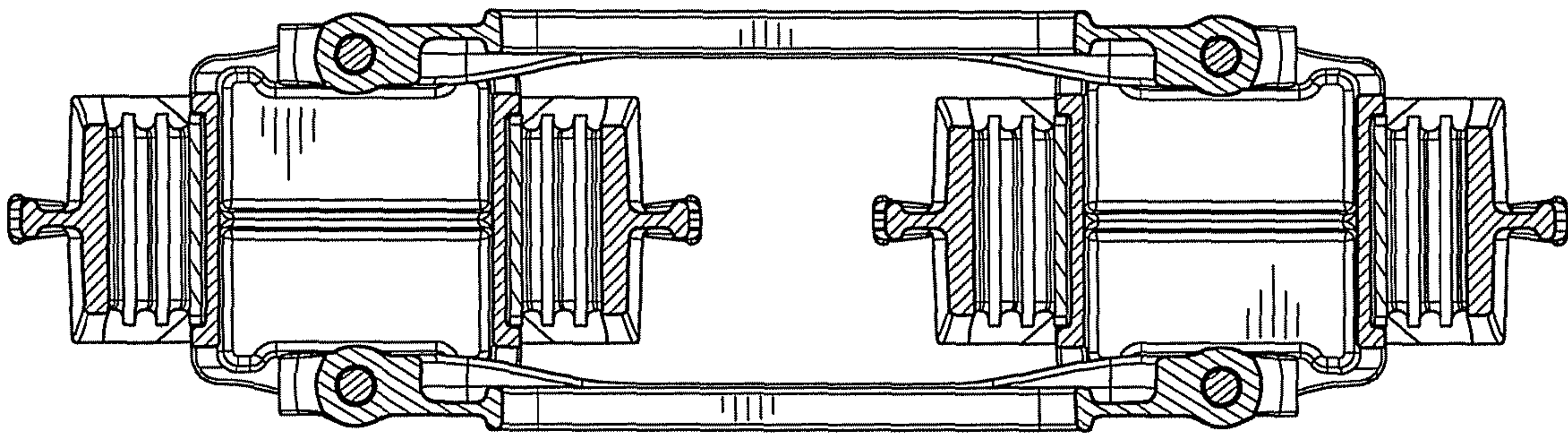

FIG. 15

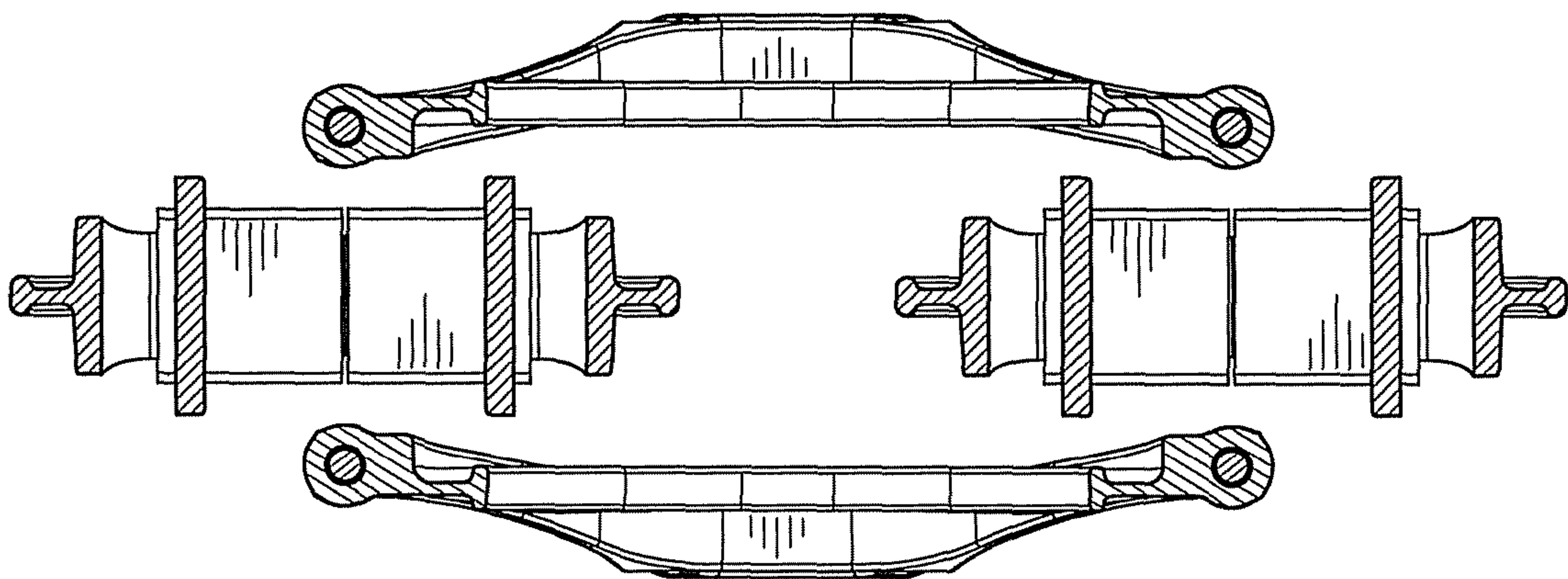

FIG. 16



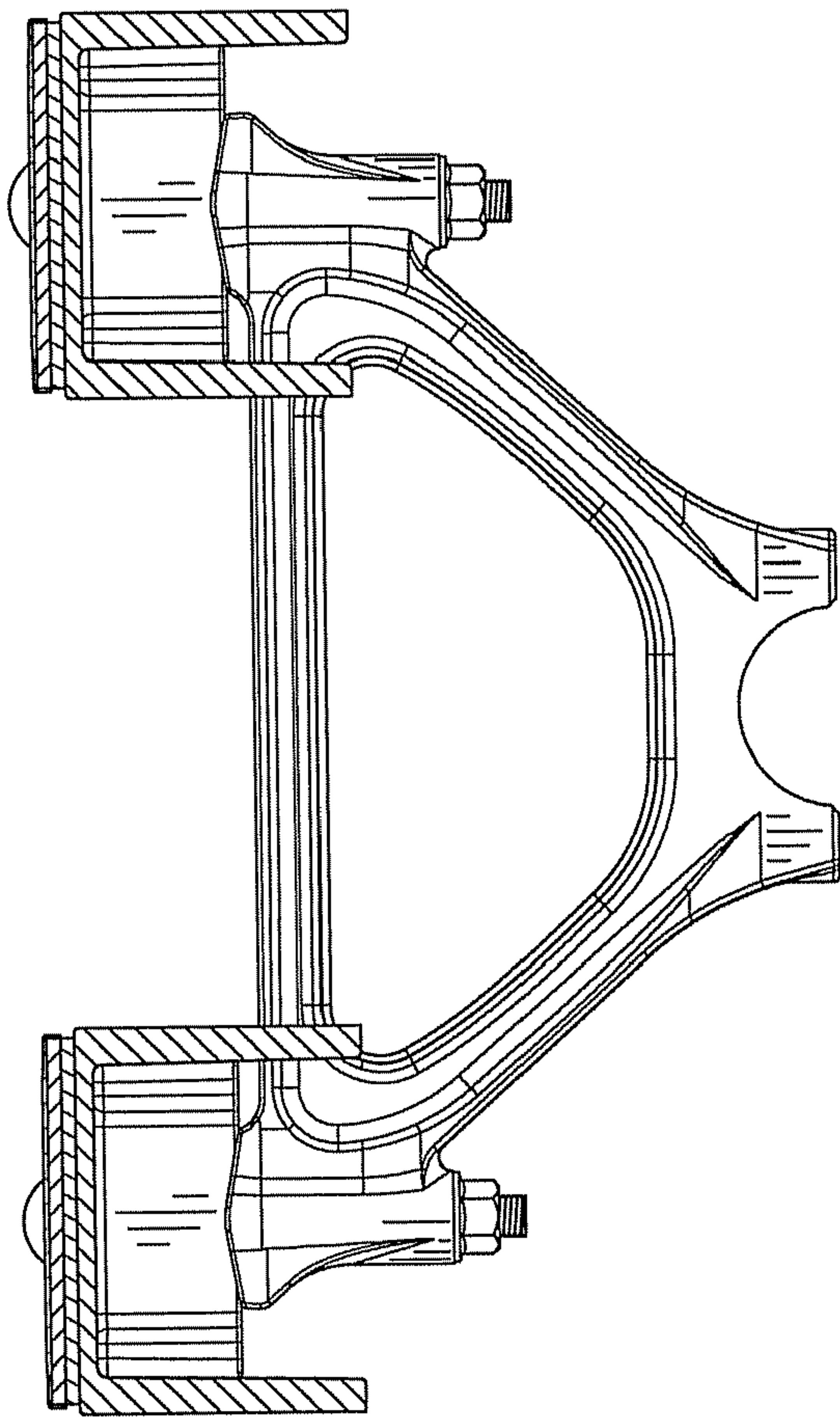

FIG. 17

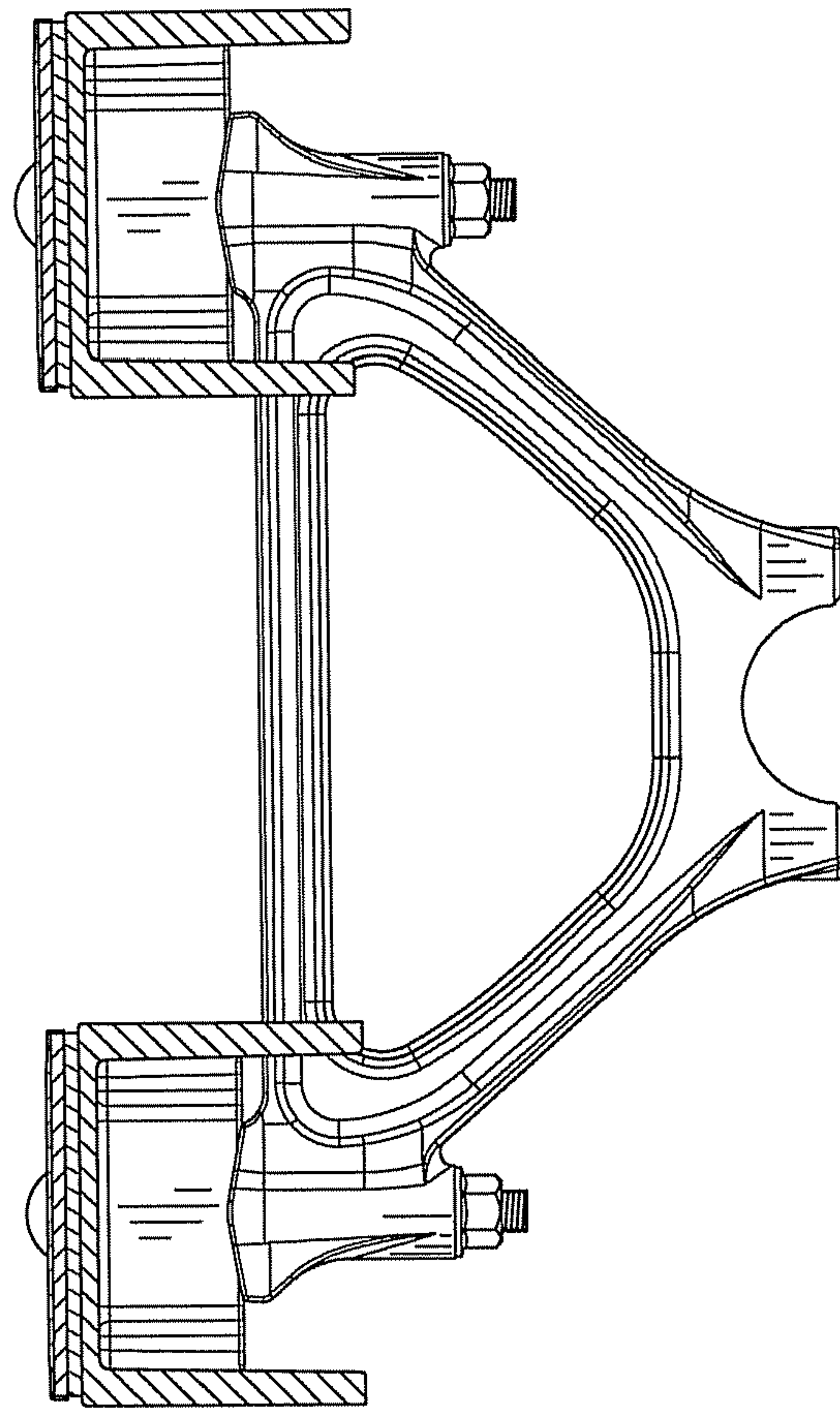

FIG. 18

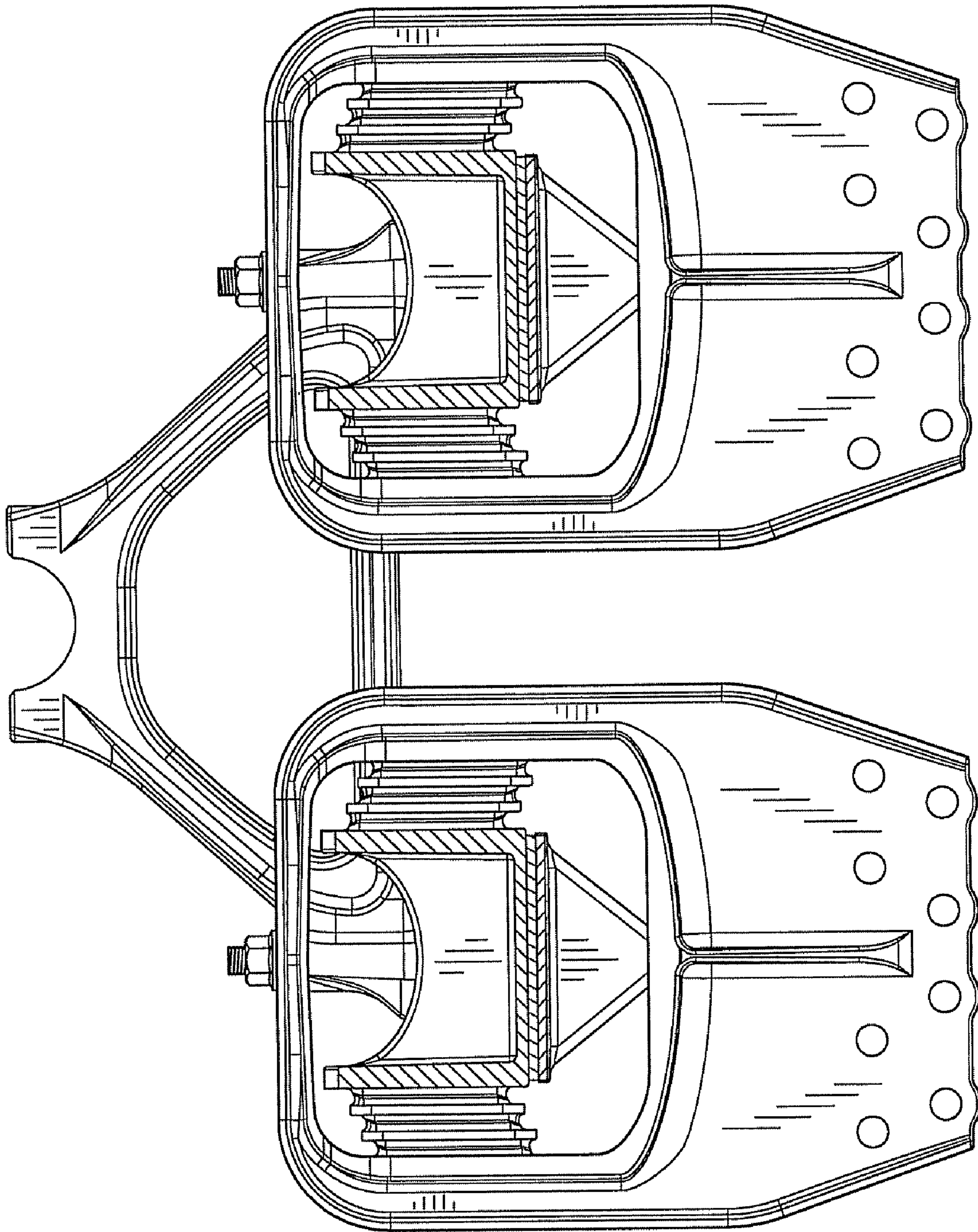

FIG. 19



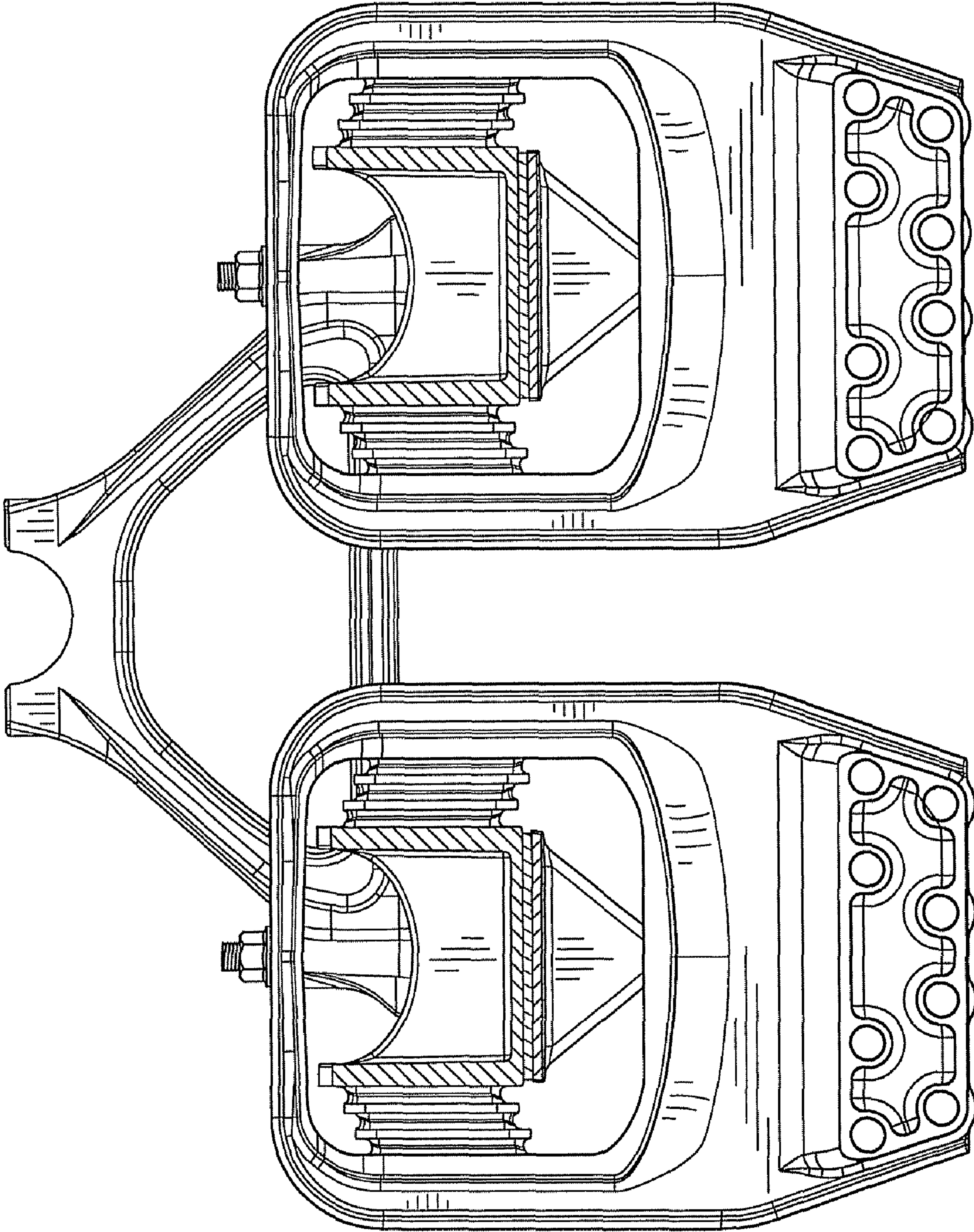

FIG. 20



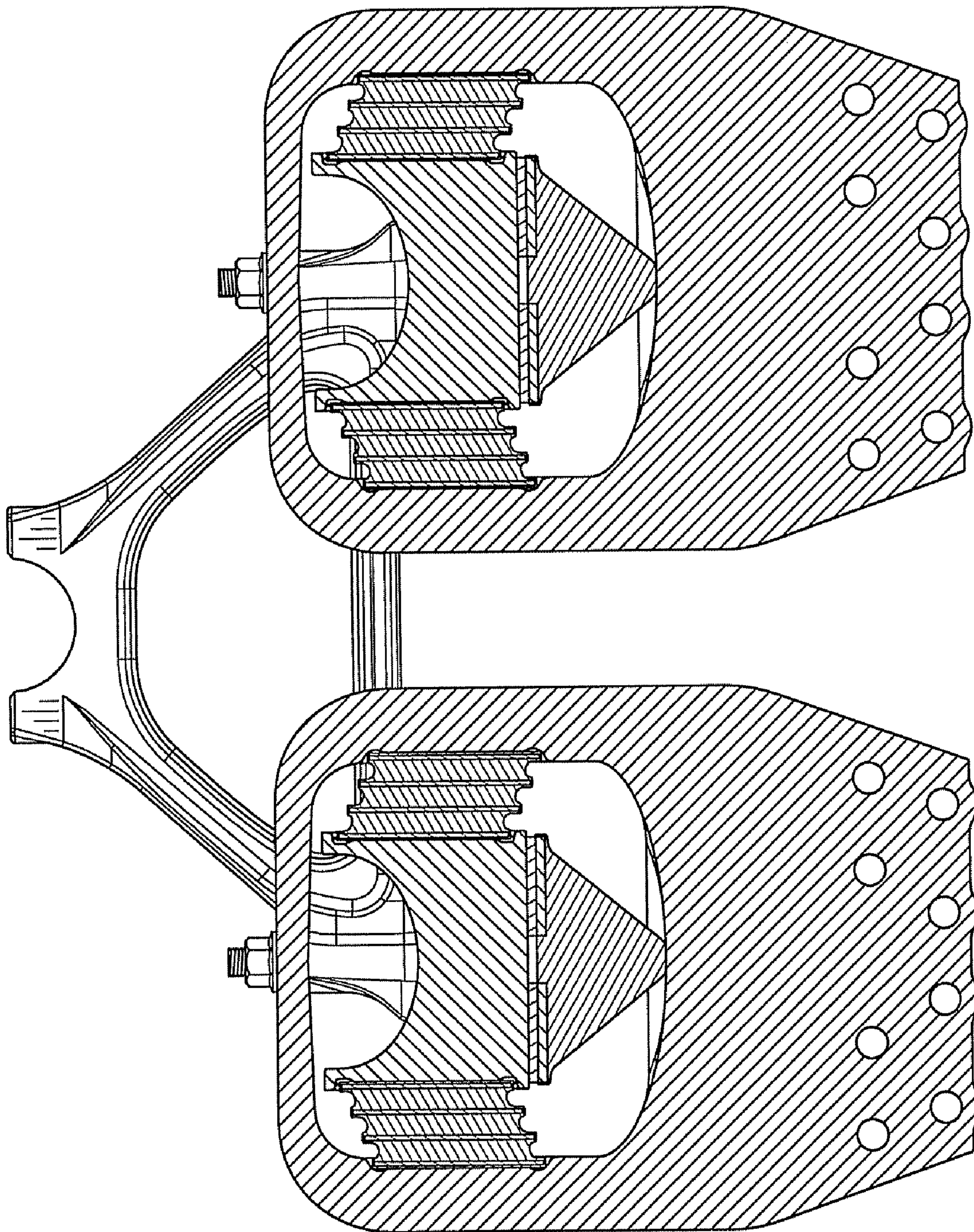

FIG. 21



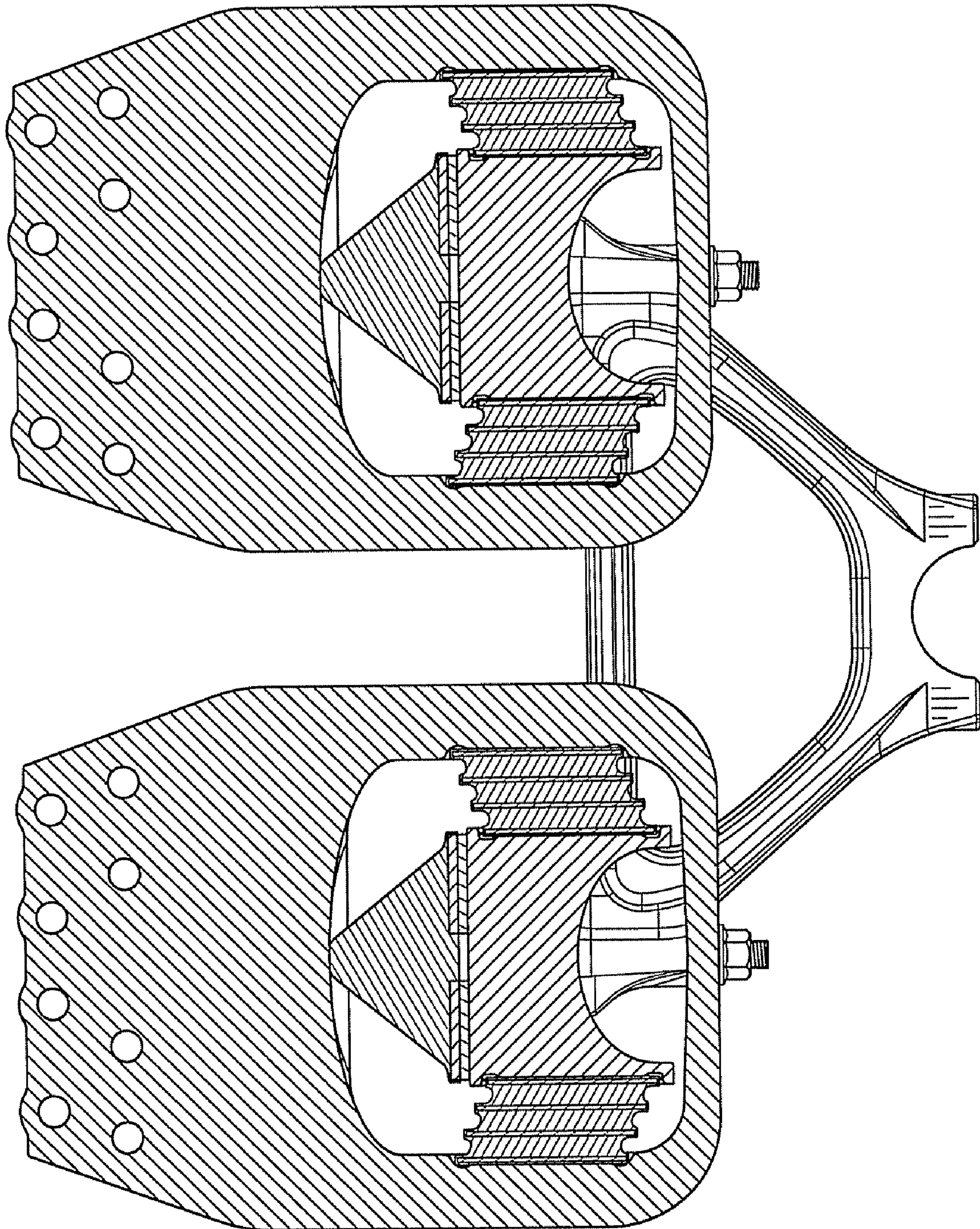

FIG. 22

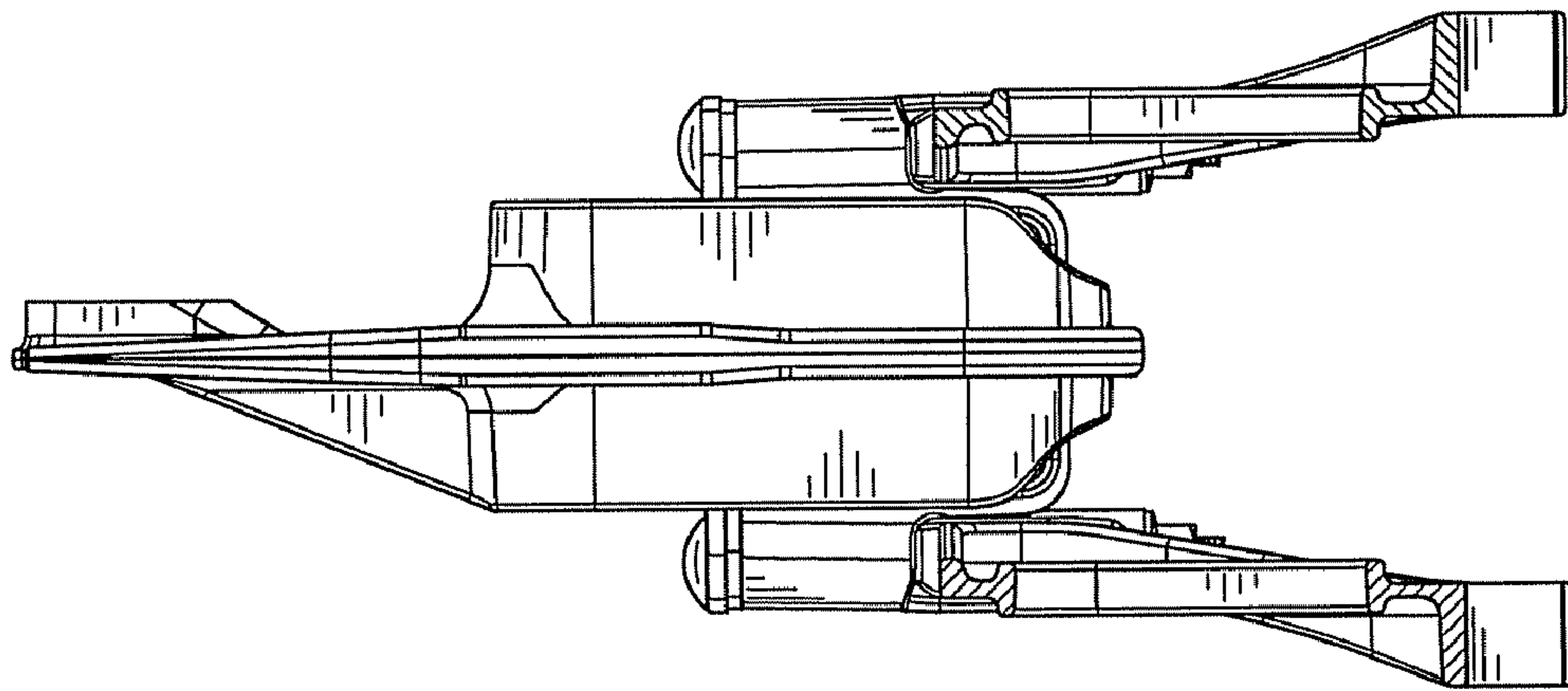

FIG. 23

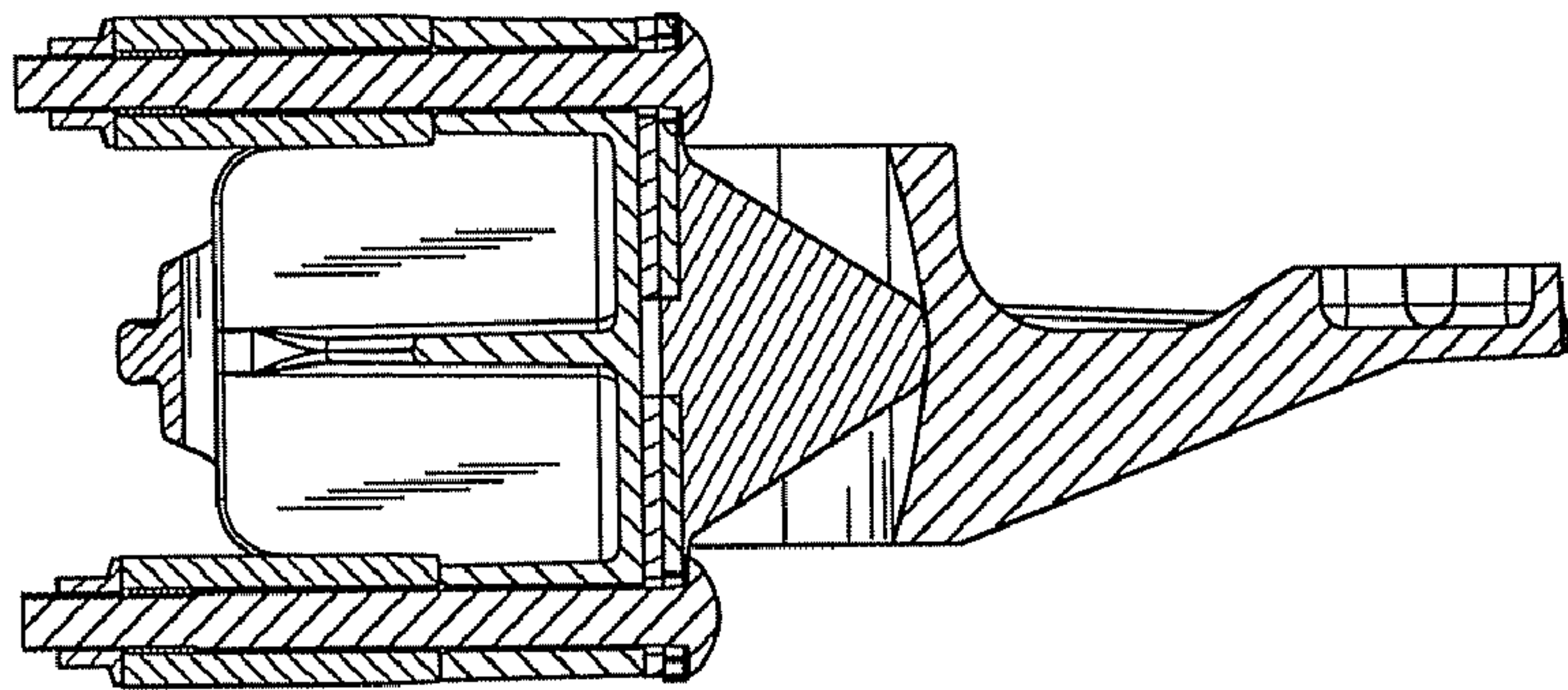

FIG. 24

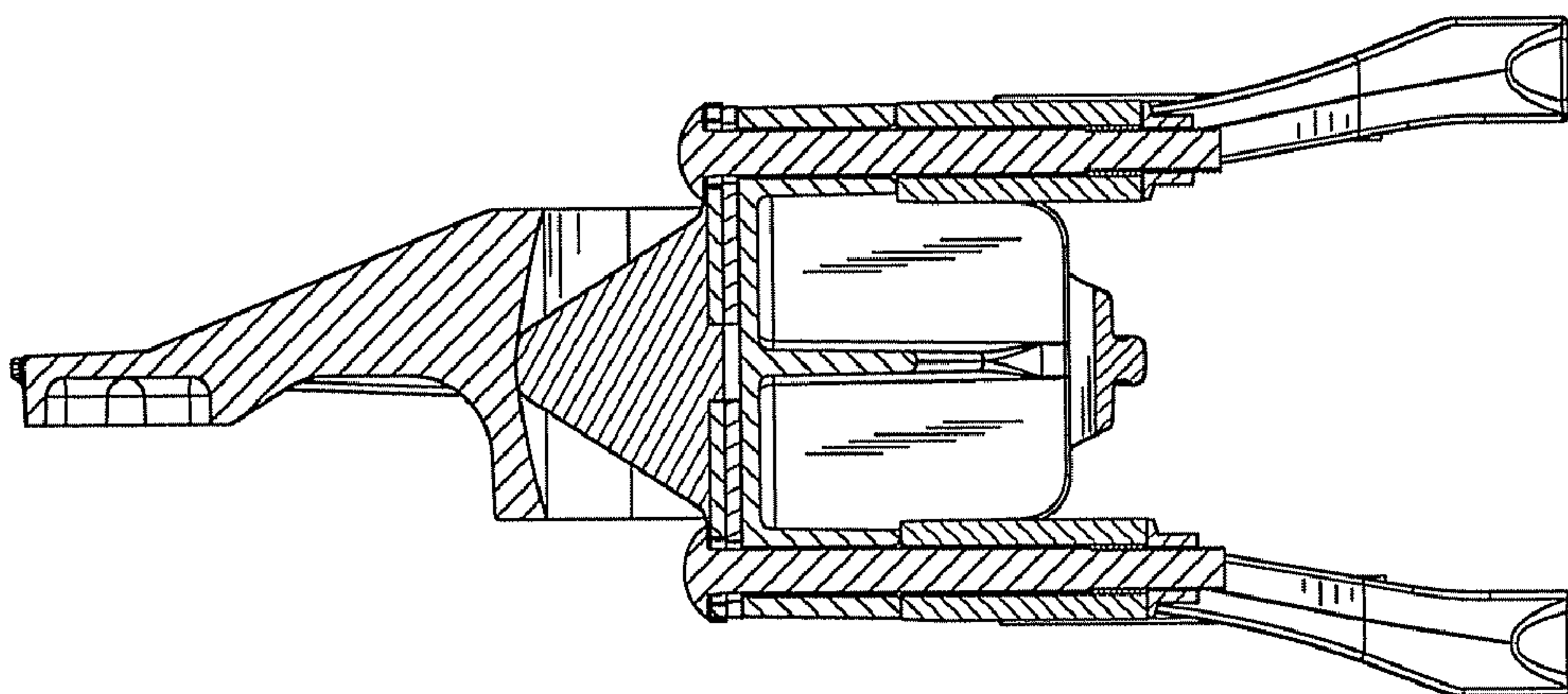

FIG. 25



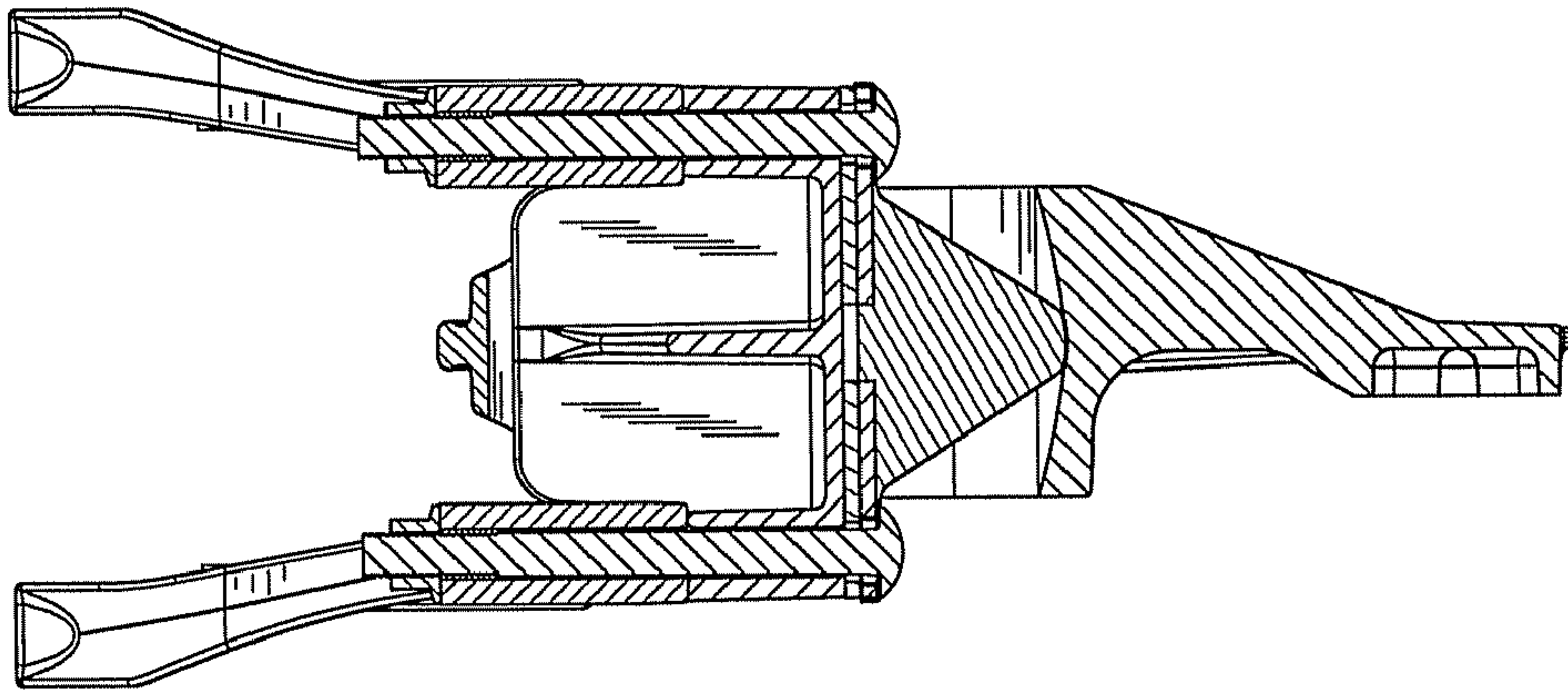

FIG. 26

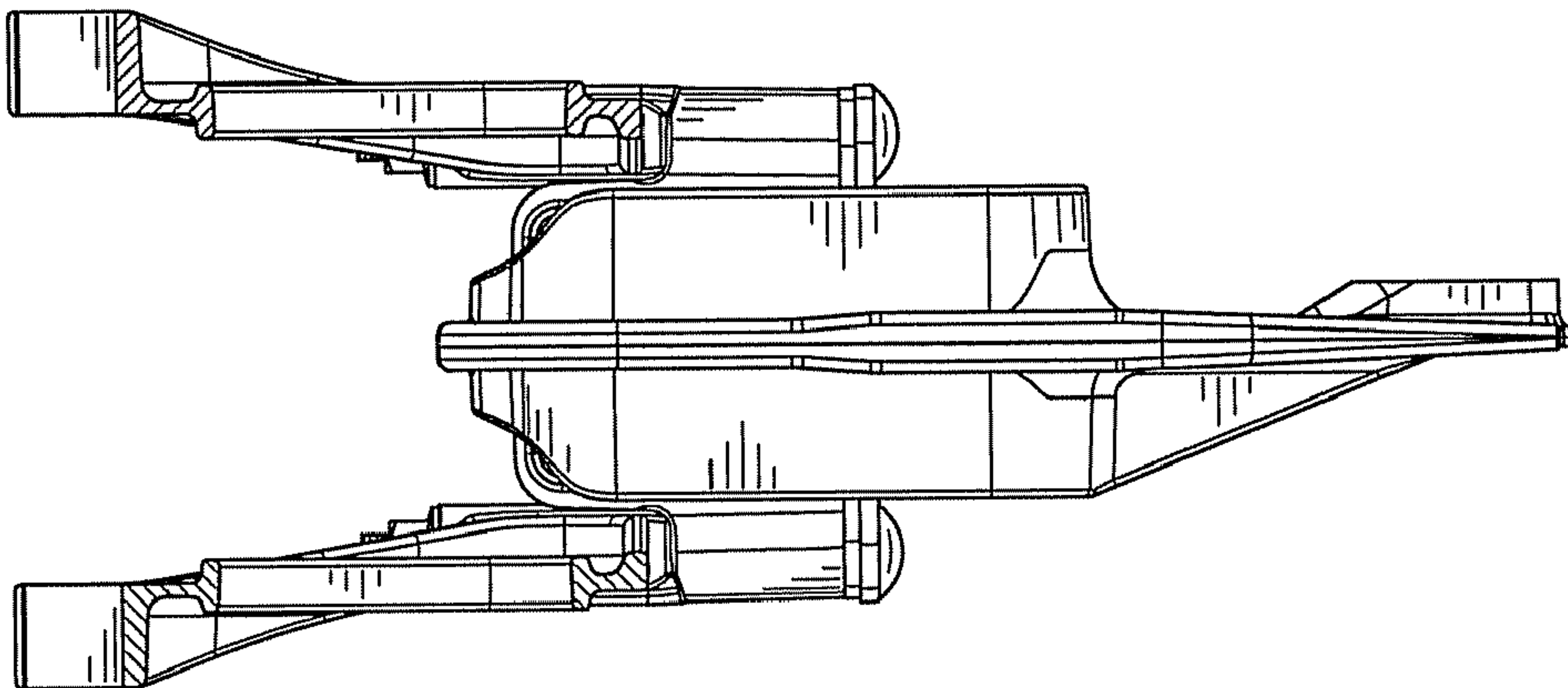

FIG. 27

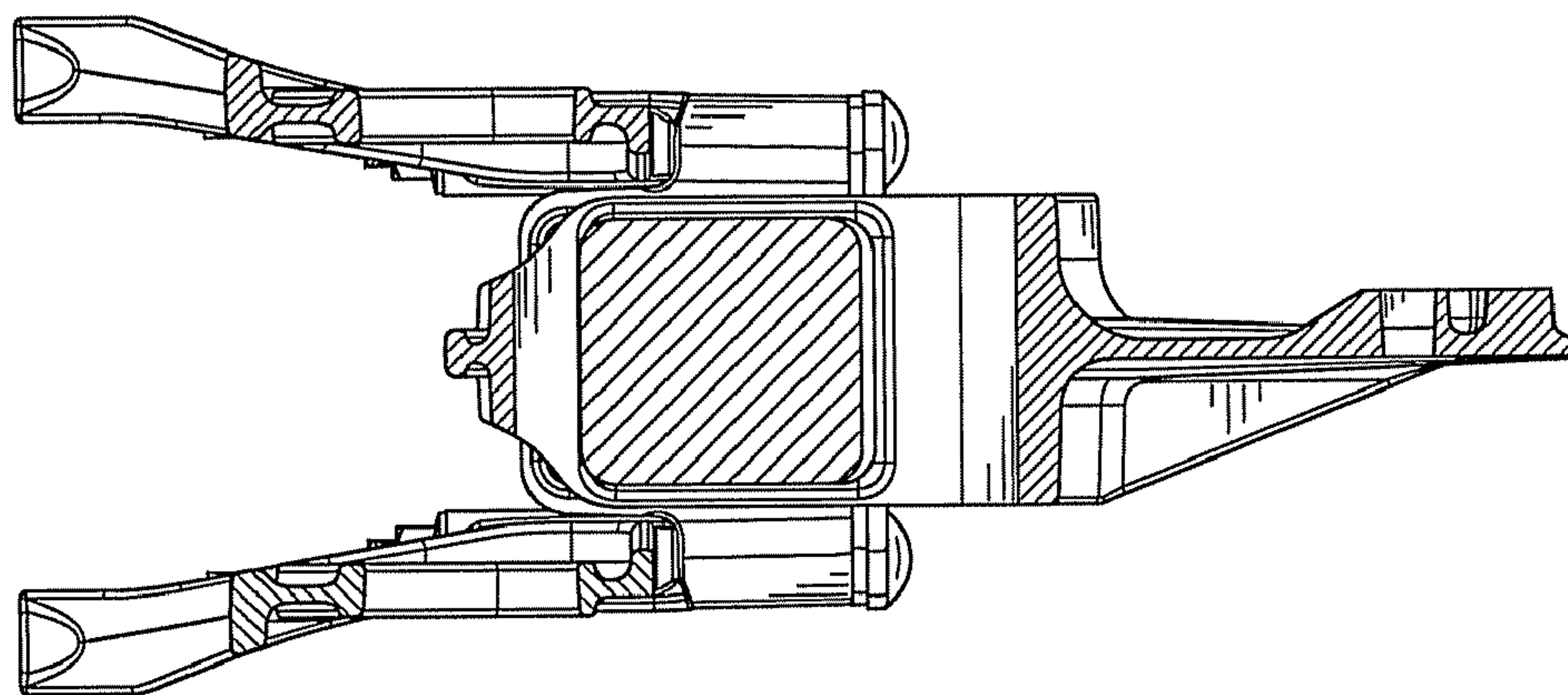

FIG. 28

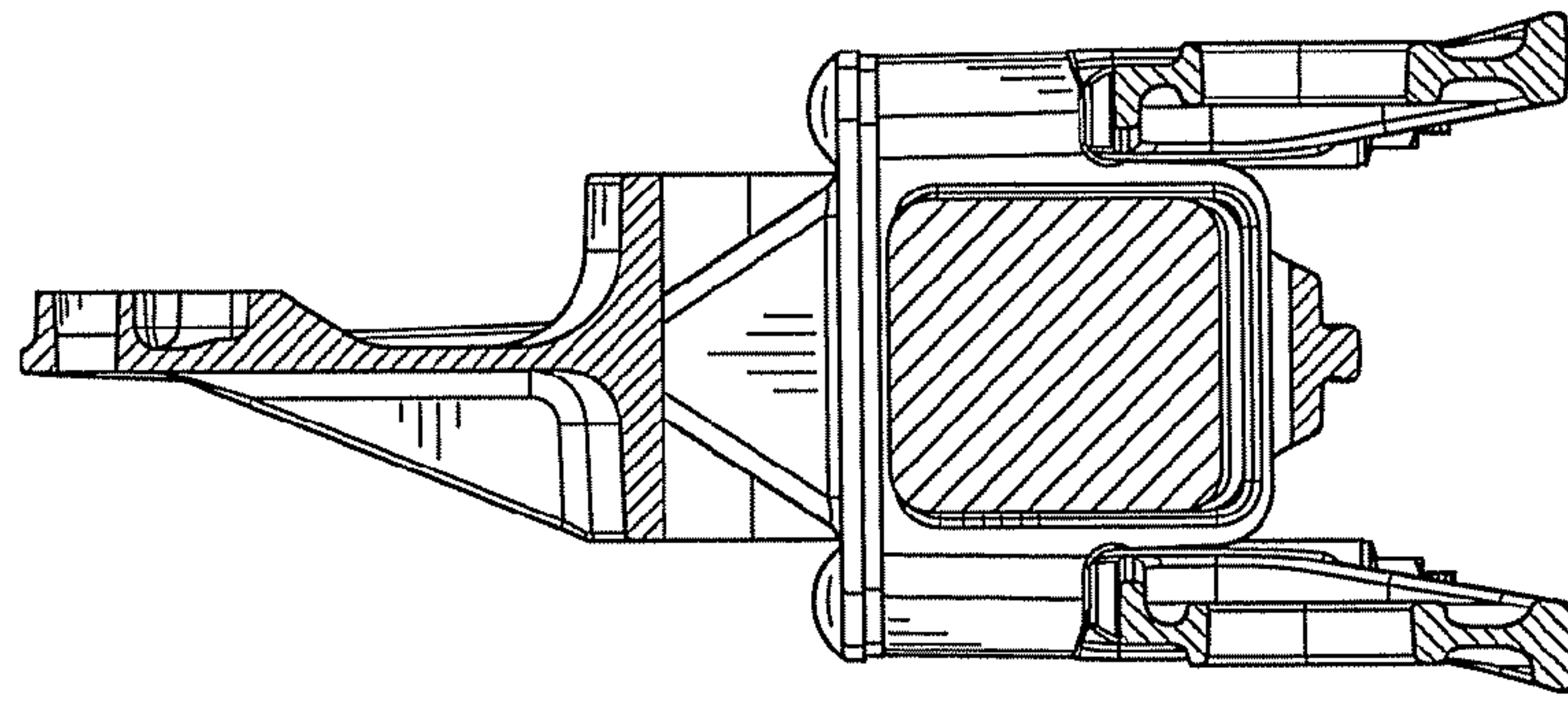

FIG. 29

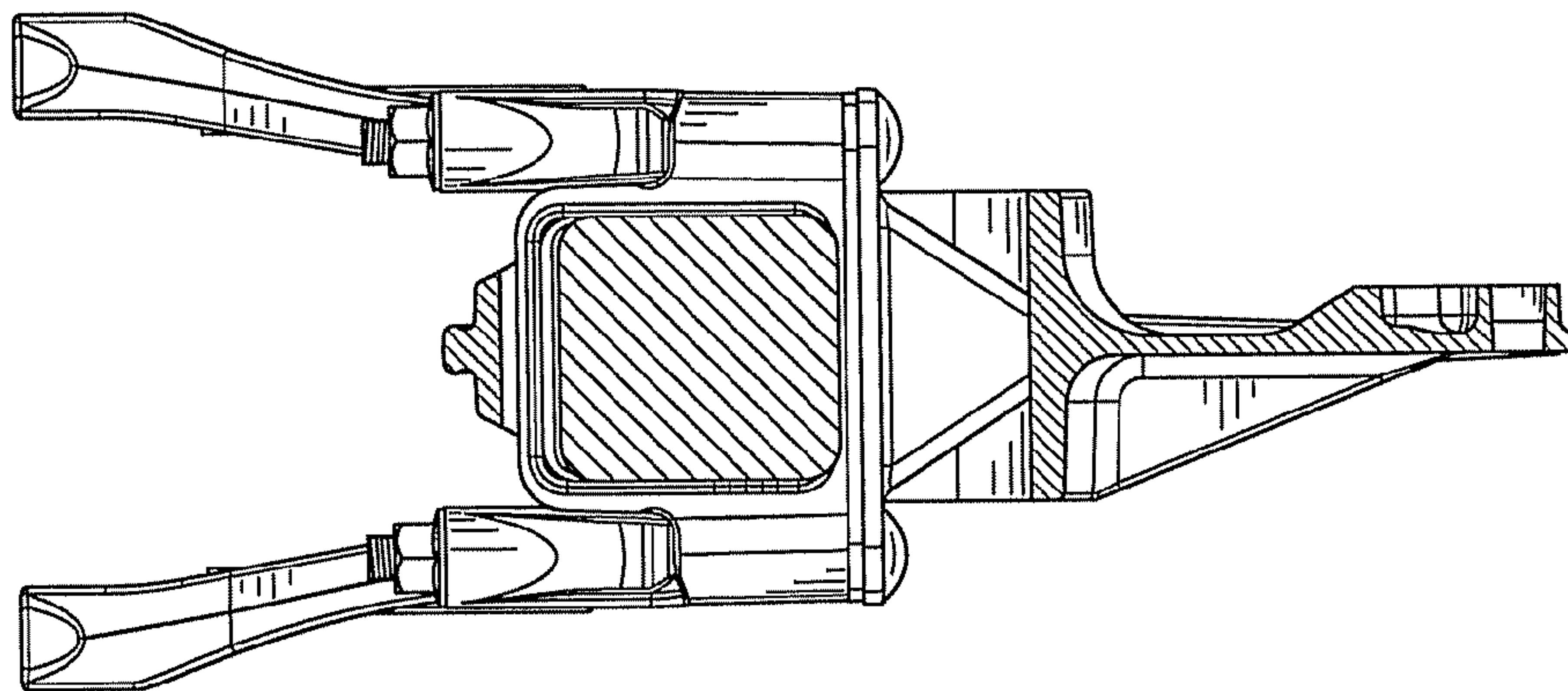

FIG. 30

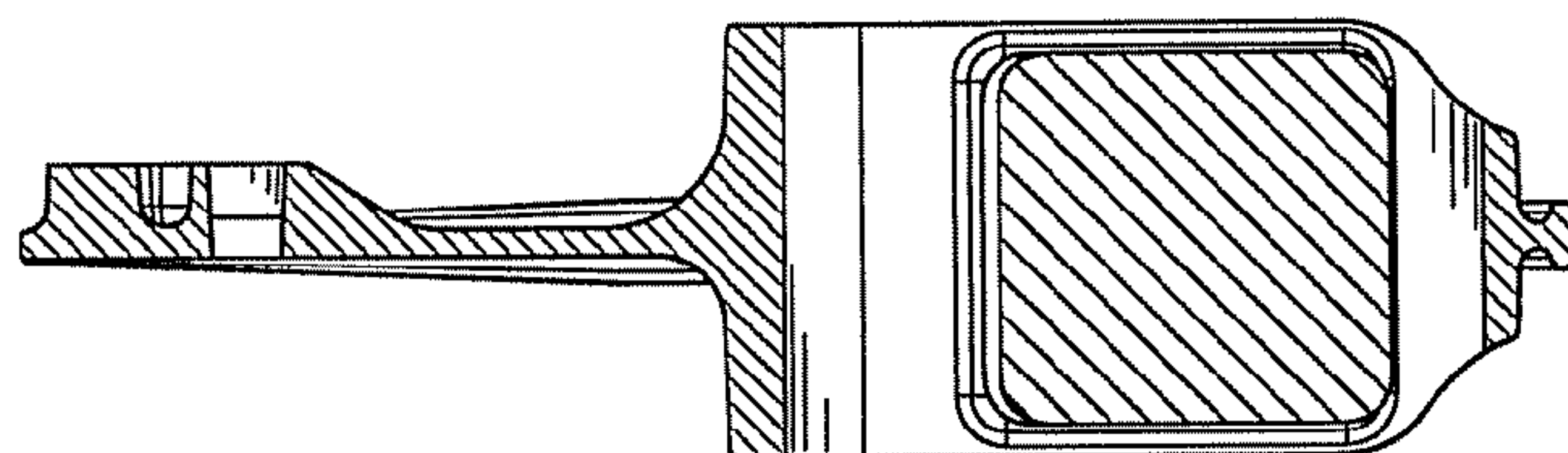

FIG. 31

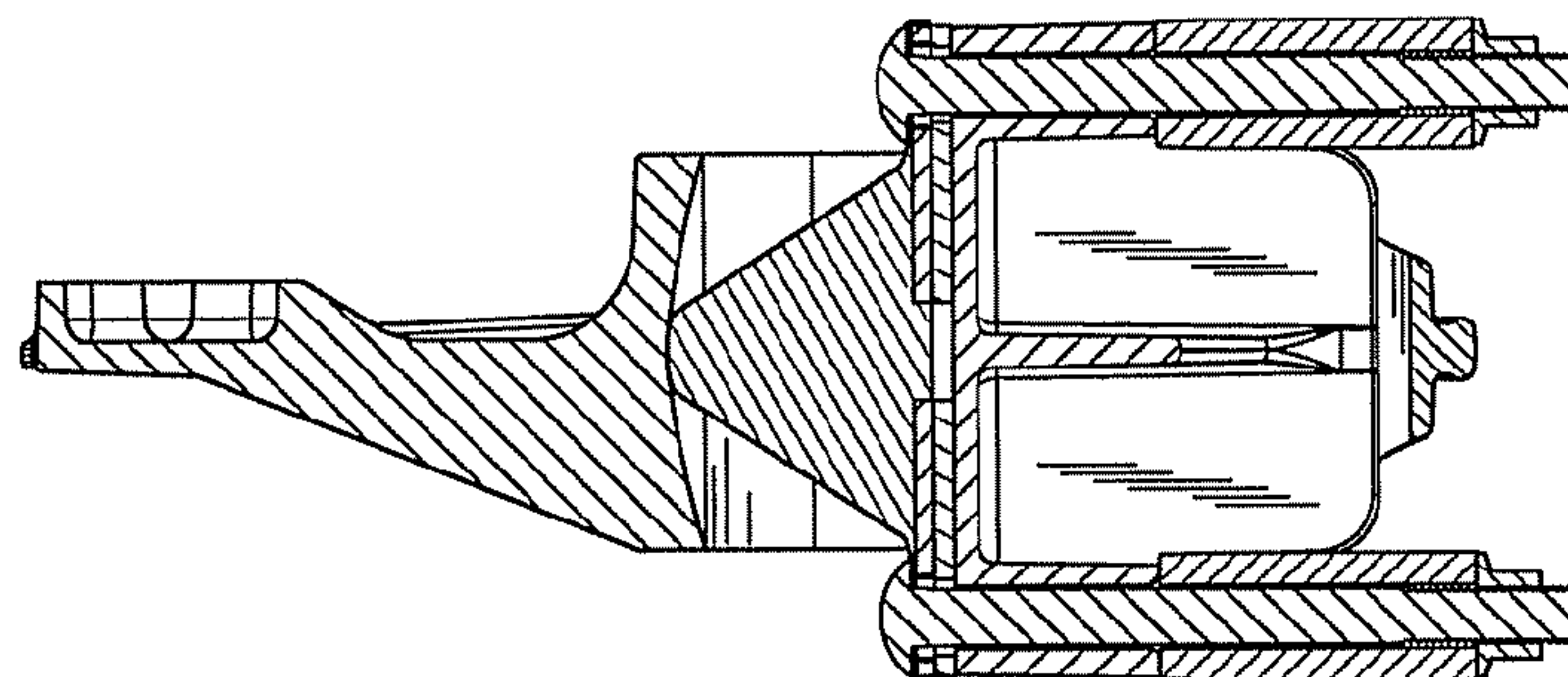

FIG. 32



UNITED STATES PATENT AND TRADEMARK OFFICE  
**CERTIFICATE OF CORRECTION**

PATENT NO. : D624,465 S  
APPLICATION NO. : 29/339134  
DATED : September 28, 2010  
INVENTOR(S) : Shawn D. Noble et al.

Page 1 of 1

It is certified that error appears in the above-identified patent and that said Letters Patent is hereby corrected as shown below:

Replace the Assignee name listed on the Patent with Hendrickson USA, L.L.C., Itasca, IL (US)

Signed and Sealed this  
Twenty-fifth Day of January, 2011

A handwritten signature in black ink that reads "David J. Kappos". The signature is written in a cursive style with a large initial "D" and "K".

David J. Kappos  
*Director of the United States Patent and Trademark Office*