



US00D624136S

(12) **United States Design Patent**
Chen

(10) **Patent No.:** **US D624,136 S**

(45) **Date of Patent:** **** Sep. 21, 2010**

(54) **WHEEL SKATE DEVICE**

(76) **Inventor:** **Shane Chen**, 4901 NW. Camas
Meadows Dr., Camas, WA (US) 98607

(**) **Term:** **14 Years**

(21) **Appl. No.:** **29/332,331**

(22) **Filed:** **Feb. 13, 2009**

(51) **LOC (9) Cl.** **21-02**

(52) **U.S. Cl.** **D21/760**

(58) **Field of Classification Search** D21/563,
D21/760, 763, 764, 771, 779; D12/107;
280/11.19, 11.24, 11.212, 11.204, 11.201,
280/11.209, 809, 811, 828, 29, 200

See application file for complete search history.

(56) **References Cited**

U.S. PATENT DOCUMENTS

| | | | | | |
|-----------|-----|---------|--------------|-------|------------|
| 1,023,882 | A * | 4/1912 | Schiesari | | 280/11.204 |
| 2,520,793 | A * | 8/1950 | Blackwell | | 280/11.24 |
| 2,675,243 | A * | 4/1954 | King | | 280/11.24 |
| 2,931,012 | A * | 3/1960 | Kosach | | 362/464 |
| 3,663,031 | A * | 5/1972 | Young | | 280/11.24 |
| D226,440 | S * | 3/1973 | Bentley | | D21/763 |
| D233,619 | S * | 11/1974 | Kelling | | D21/763 |
| 4,108,451 | A * | 8/1978 | Scheck, Sr. | | 280/11.212 |
| 4,363,493 | A * | 12/1982 | Veneklasen | | 280/11.204 |
| 4,709,937 | A * | 12/1987 | Lin et al. | | 280/11.209 |
| D324,252 | S * | 2/1992 | Williamson | | D21/763 |
| 5,106,110 | A * | 4/1992 | Williamson | | 280/11.212 |
| D347,044 | S * | 5/1994 | Slack et al. | | D21/763 |
| D393,037 | S * | 3/1998 | Priester | | D21/771 |

| | | | | | |
|-----------|------|--------|-----------------|-------|-----------|
| 5,779,247 | A * | 7/1998 | Anselmo | | 280/11.24 |
| 6,382,640 | B1 * | 5/2002 | Killian | | 280/11.24 |
| D535,714 | S * | 1/2007 | Cheng et al. | | D21/763 |
| D567,318 | S * | 4/2008 | Farrelly et al. | | D21/763 |

* cited by examiner

Primary Examiner—Cynthia M Chin

(74) *Attorney, Agent, or Firm*—Steven J. Adamson

(57) **CLAIM**

The ornamental design for a wheel skate device, as shown and described.

DESCRIPTION

FIG. 1 is a top plan view of the wheel skate device according to my new design;

FIG. 2 is a front elevational view thereof, the rear elevational view being a mirror image of FIG. 2;

FIG. 3 is a left side elevational view thereof, the right side elevational view being a mirror image of FIG. 3;

FIG. 4 is a bottom plan view thereof;

FIG. 5 is a perspective view thereof; and,

FIG. 6 is a top plan view of the wheel skate device according to a slight variation of my new design, wherein the only difference from the design shown in FIGS. 1-5 is the symmetry of the foot platform.

The broken lines immediately adjacent the shaded areas represent the bounds of the claim and all other broken lines represent unclaimed portions of the design. None of the broken lines form a part of the claimed design.

1 Claim, 3 Drawing Sheets

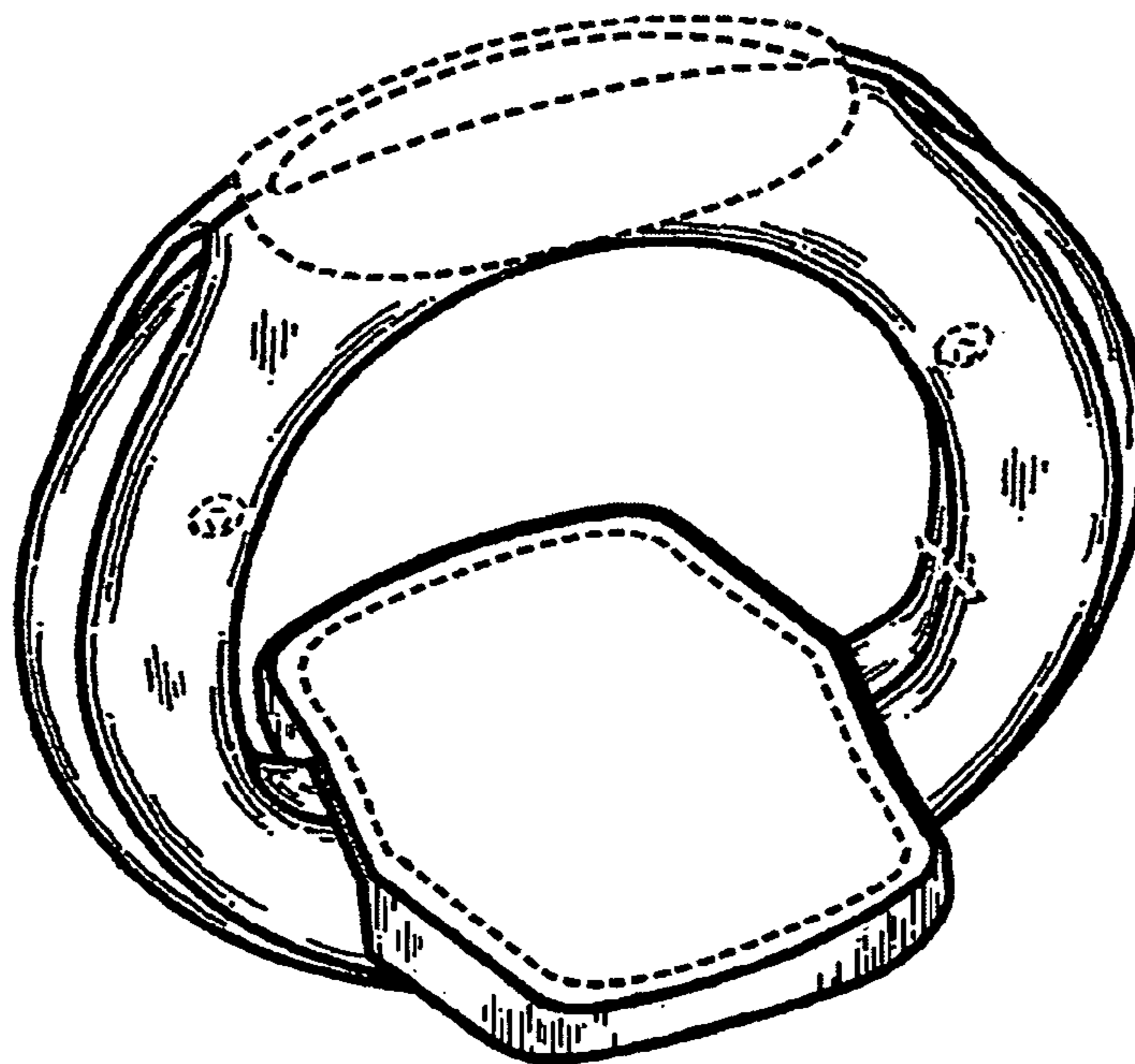

Fig. 1

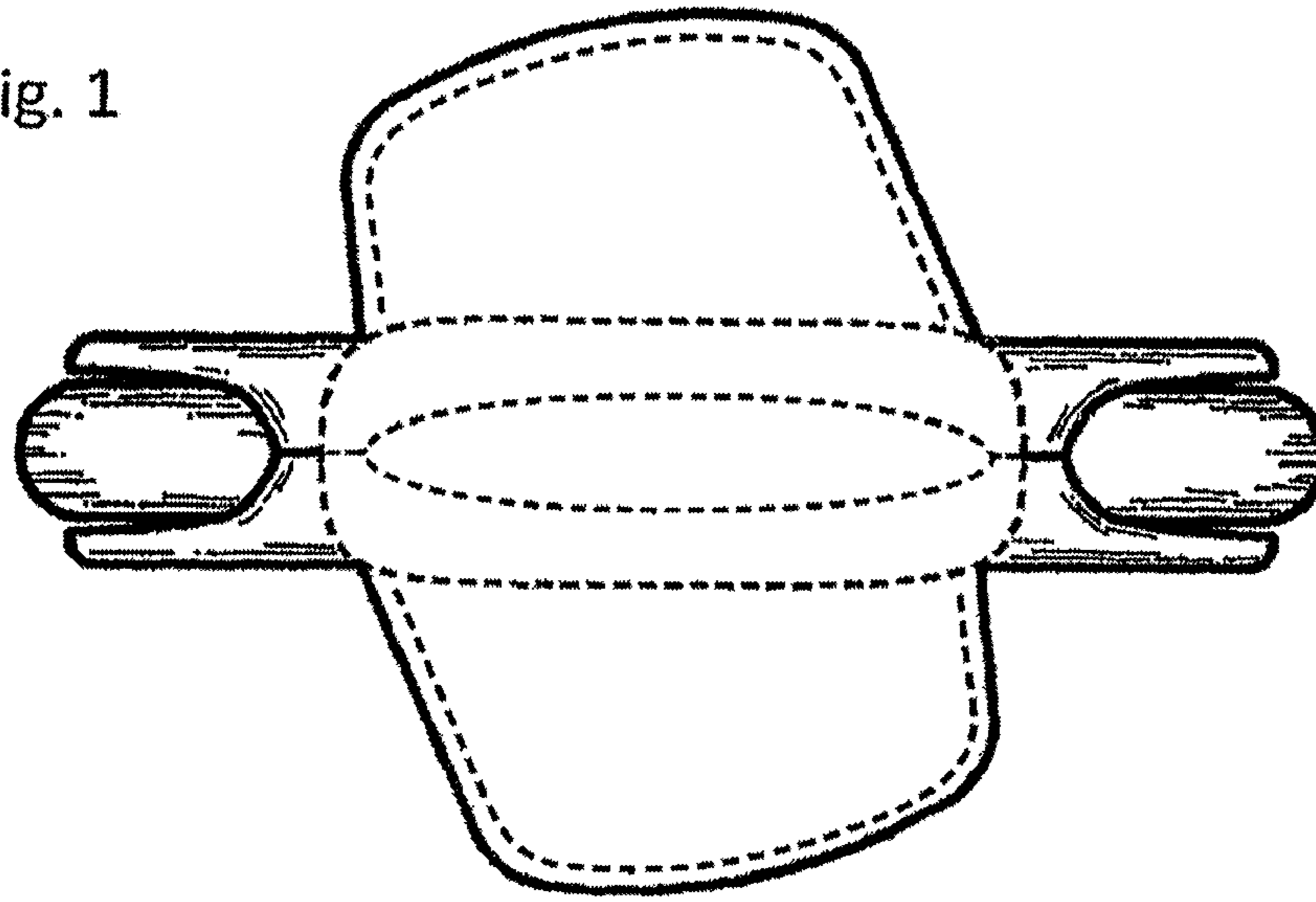

Fig. 6

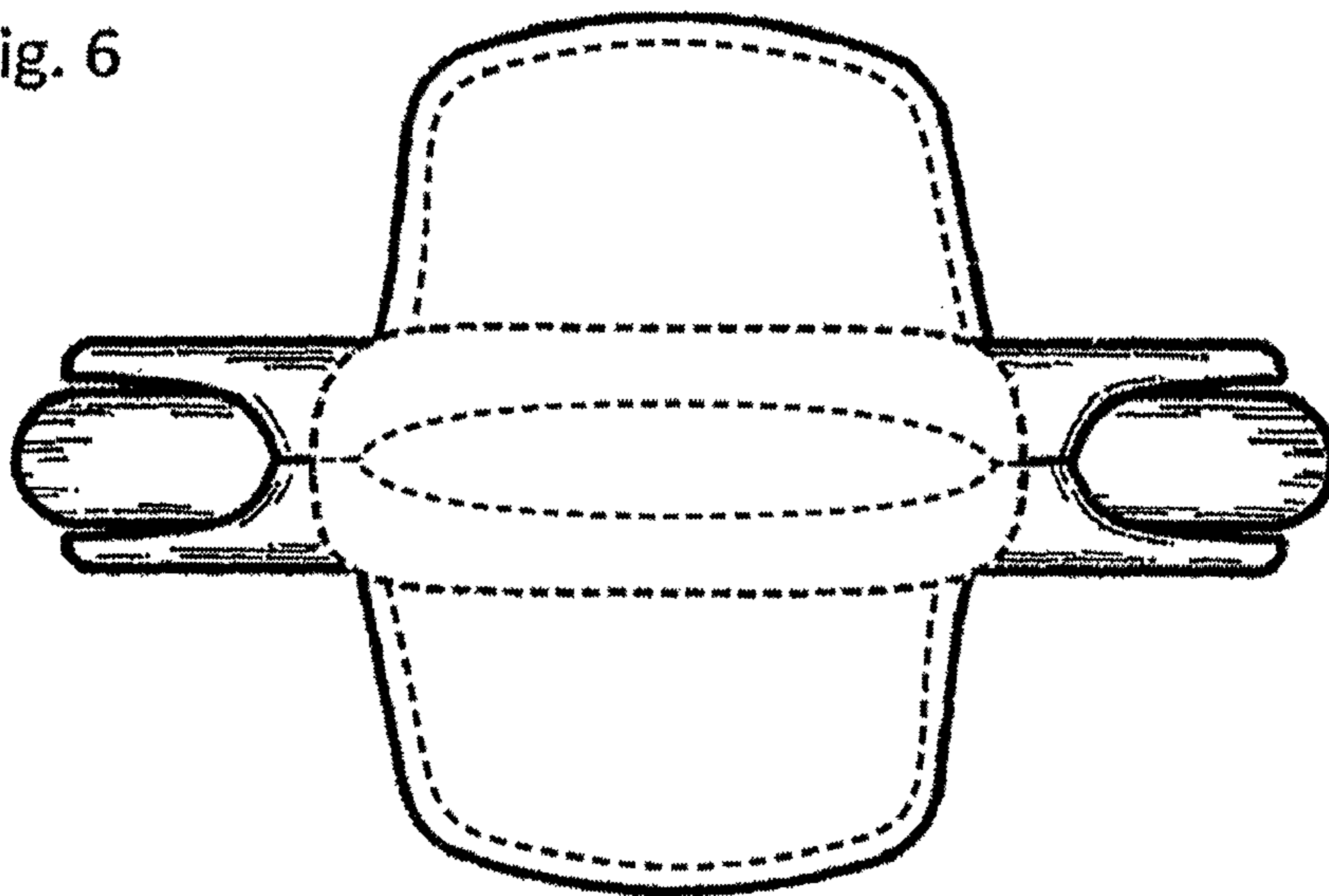

Fig. 2

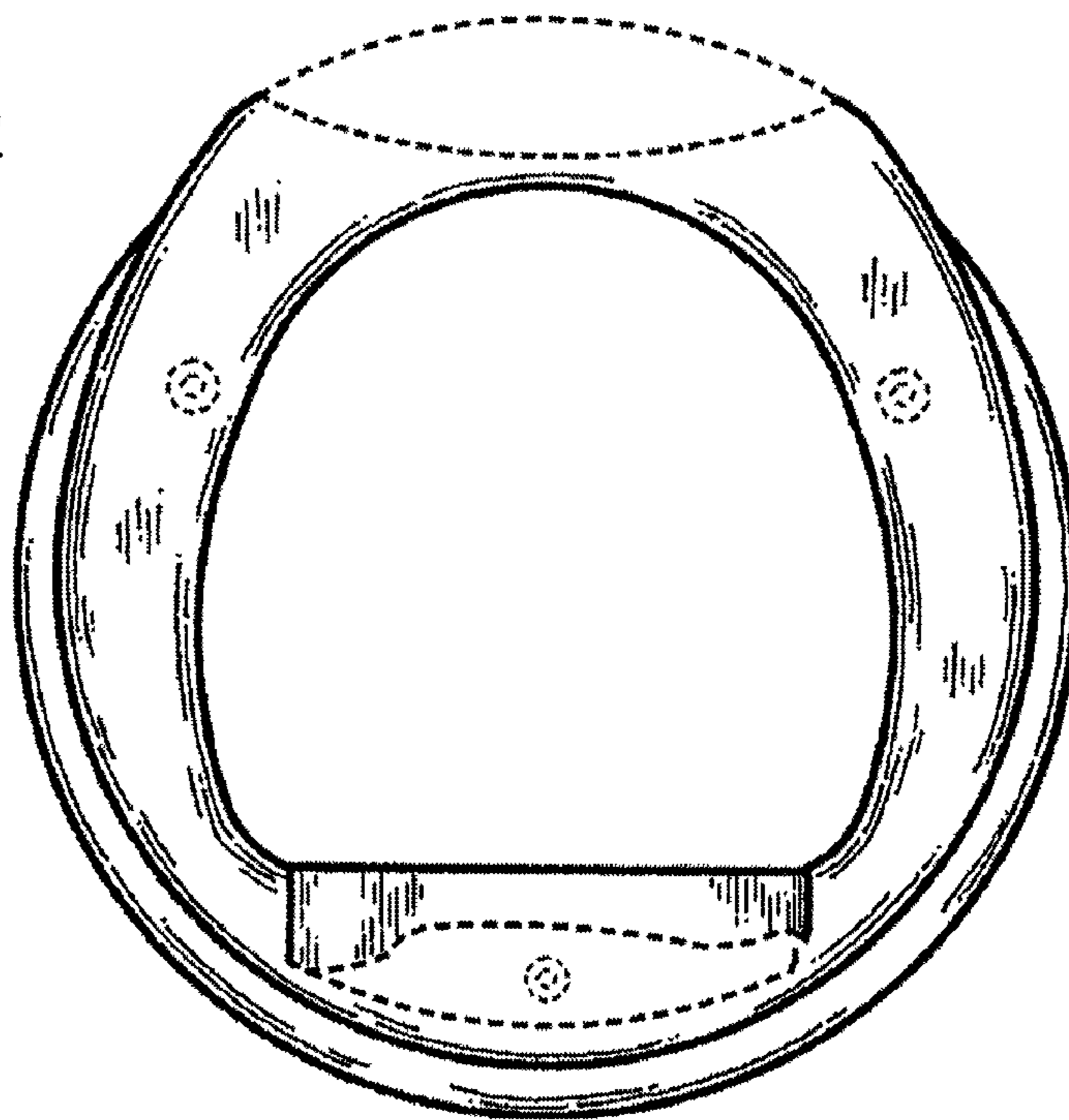

Fig. 3

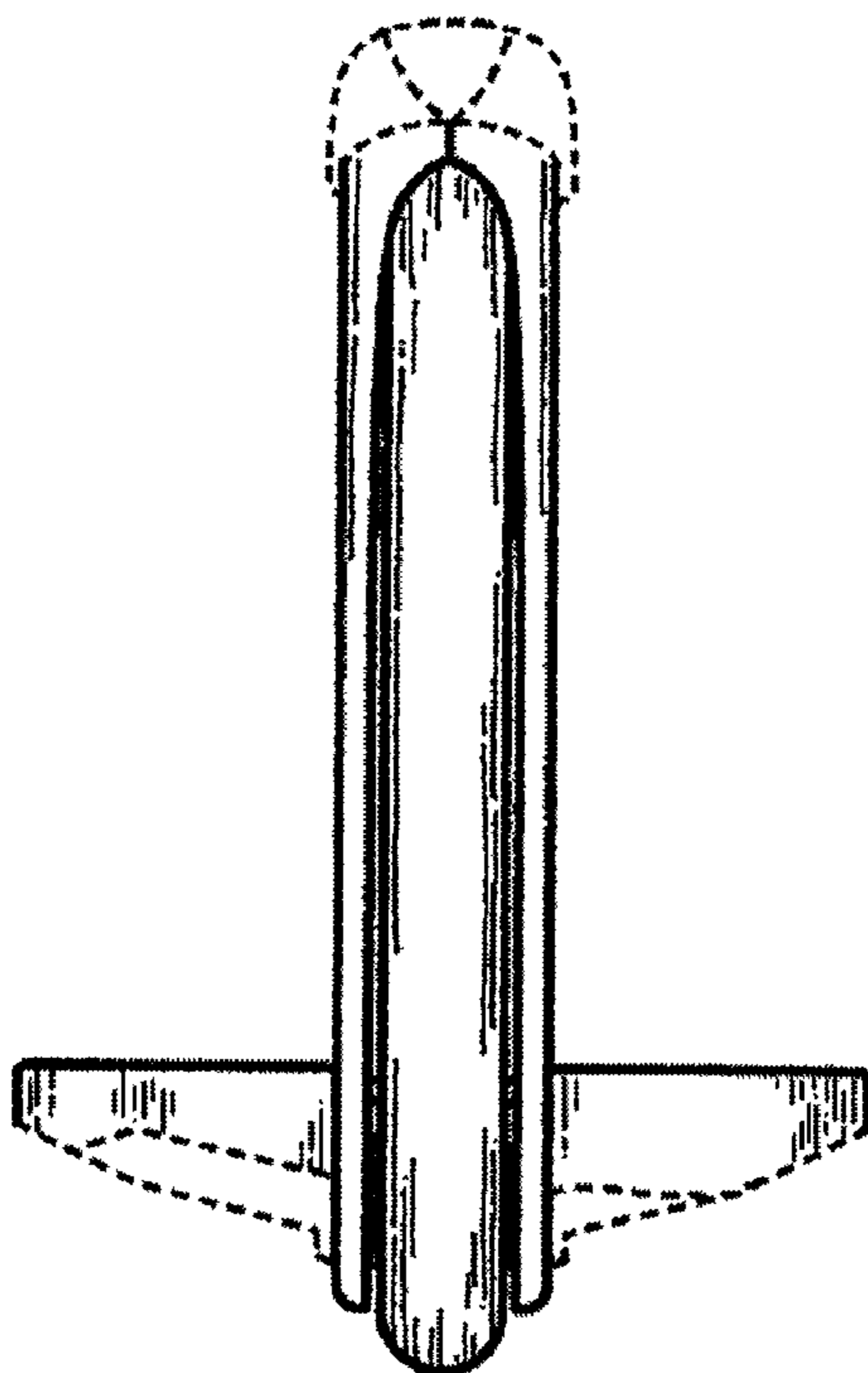

Fig. 4

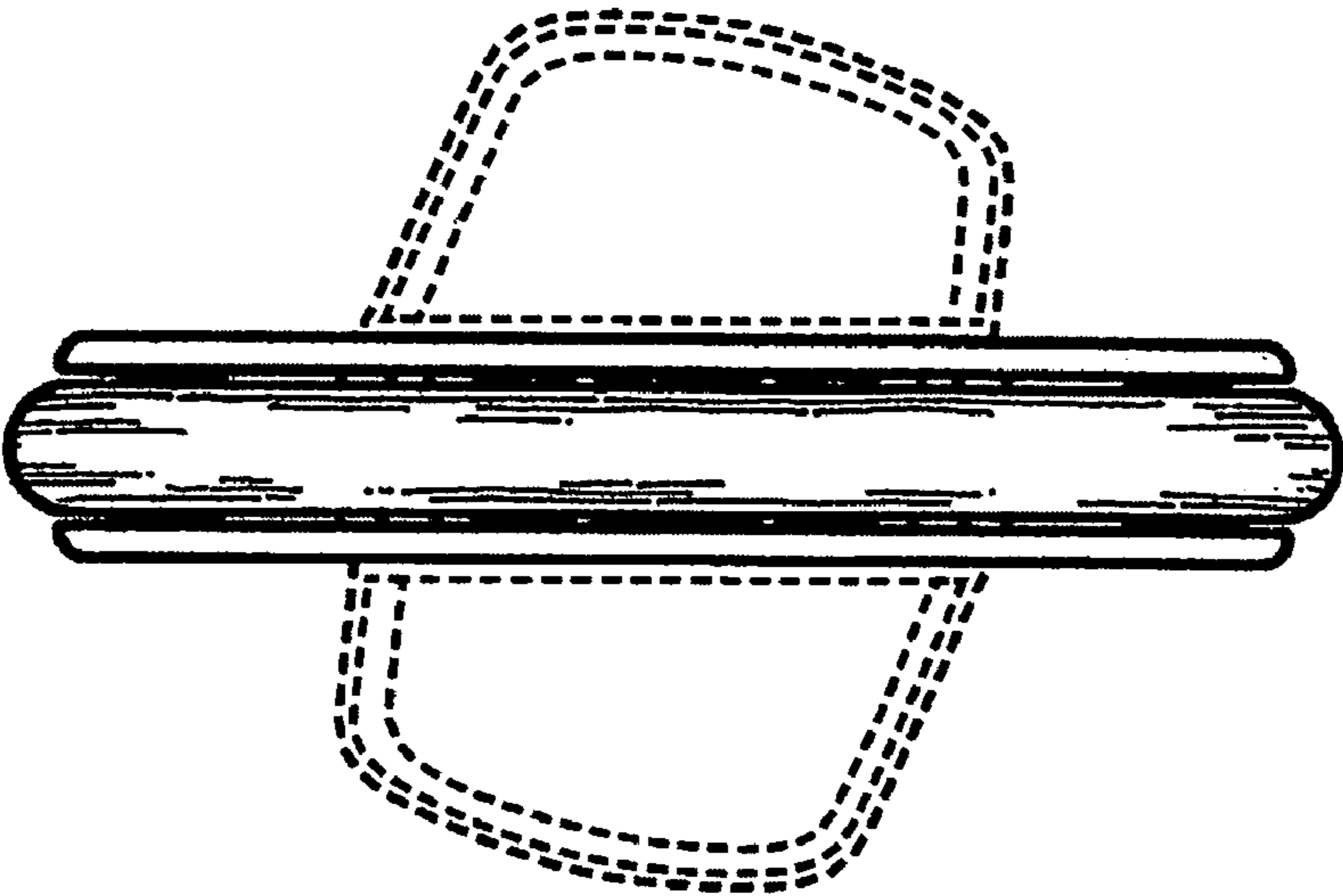

Fig. 5

