



US00D624003S

(12) **United States Design Patent**
Saint-Jalmes et al.

(10) **Patent No.:** **US D624,003 S**
(45) **Date of Patent:** **** Sep. 21, 2010**

(54) **AIRCRAFT BELLY FAIRING**

(75) Inventors: **Bruno Saint-Jalmes**, Toulouse (FR);
Jason Zaneboni, Blagnac (FR);
Bernard Rumeau, Cornebarrieu (FR)

(73) Assignee: **Airbus SAS**, Blagnac Cedex (FR)

(**) Term: **14 Years**

(21) Appl. No.: **29/343,964**

(22) Filed: **Sep. 22, 2009**

Related U.S. Application Data

(63) Continuation-in-part of application No. 29/335,123,
filed on Apr. 9, 2009.

(51) **LOC (9) Cl.** **12-07**

(52) **U.S. Cl.** **D12/345**

(58) **Field of Classification Search** D12/181,
D12/319, 345; 244/129.1, 130; 440/66
See application file for complete search history.

(56) **References Cited**

U.S. PATENT DOCUMENTS

D177,029 S *	3/1956	Frost et al.	D12/340
D274,142 S *	6/1984	McNab et al.	D12/345
D295,970 S *	5/1988	McNab et al.	D12/345
D338,442 S *	8/1993	Callan	D12/181
D370,456 S *	6/1996	Buchsel et al.	D12/340
D375,925 S *	11/1996	Griffin	D12/181
D497,586 S *	10/2004	Ferguson	D12/345
D497,786 S *	11/2004	Concari	D8/68
D582,832 S *	12/2008	Dornier	D12/337

OTHER PUBLICATIONS

ATR Pictures Media Gallery, ATR GIE [online], 2008, [retrieved on
Aug. 4, 2009]. Retrieved from the Internet: < URL: <http://www.atr.fr/public/atr/html/media/pictures.php>>.

Q400 NextGen, Bombardier [online], 1997-2008, [retrieved on Aug.
4, 2009]. Retrieved from the Internet: <URL: <http://www.q400.com/q400/en/home.jsp>>.

Turbo Prop Airliner Production List; J Roach, A.B. Eastwood
[online], [retrieved on Aug. 4, 2009]. Retrieved from the Internet: <
URL: <http://www.tahs.com/books/turbo.htm>>.

* cited by examiner

Primary Examiner—Cathron C. Brooks

Assistant Examiner—Maurice Stevens

(74) *Attorney, Agent, or Firm*—Olser, Hoskin & Harcourt
LLP

(57) **CLAIM**

The ornamental design for an aircraft belly fairing, as shown
and described.

DESCRIPTION

FIG. 1 is a perspective view taken from a top, left side of an
aircraft belly fairing according to our new design;

FIG. 2 is a left side elevation view thereof;

FIG. 3 is a right side elevation view thereof;

FIG. 4 is a bottom plan view thereof;

FIG. 5 is a front elevation view thereof;

FIG. 6 is a rear elevation view thereof;

FIG. 7 is a perspective view taken from a top, front, left side
of the aircraft belly fairing of FIG. 1 shown on an aircraft
shown in broken lines;

FIG. 8 is a left side elevation view of FIG. 7;

FIG. 9 is a right side elevation view of FIG. 7;

FIG. 10 is a bottom plan view of FIG. 7;

FIG. 11 is a front elevation view of FIG. 7; and,

FIG. 12 is a rear elevation of FIG. 7.

Throughout the Figures, broken lines showing environment
or structure are for illustrative purposes only and form no part
of the claimed design.

1 Claim, 12 Drawing Sheets

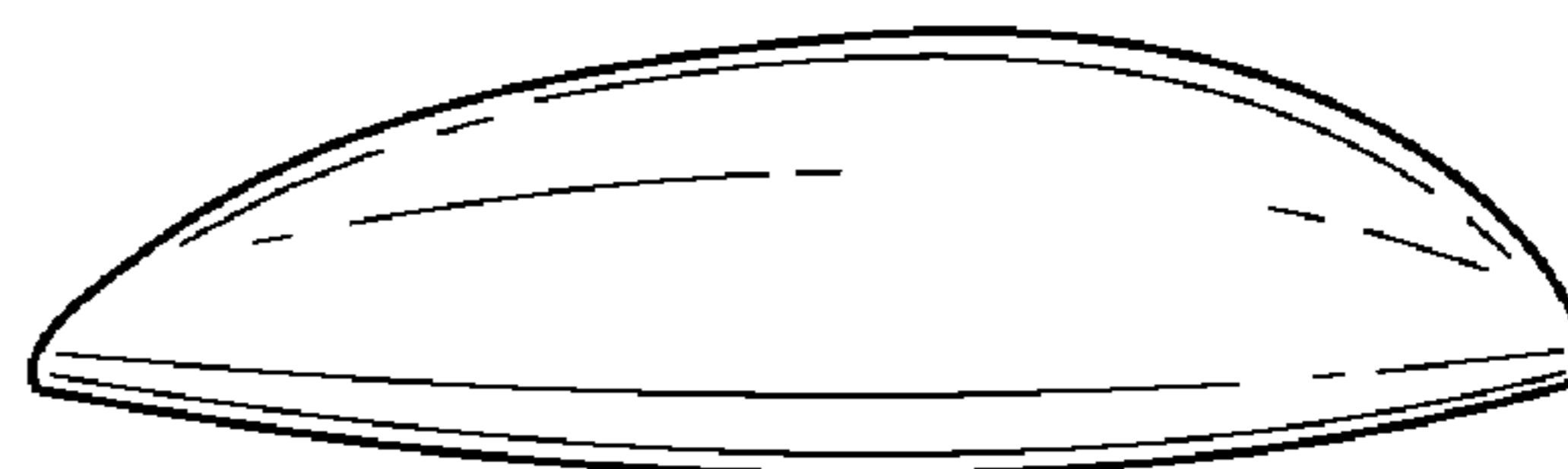
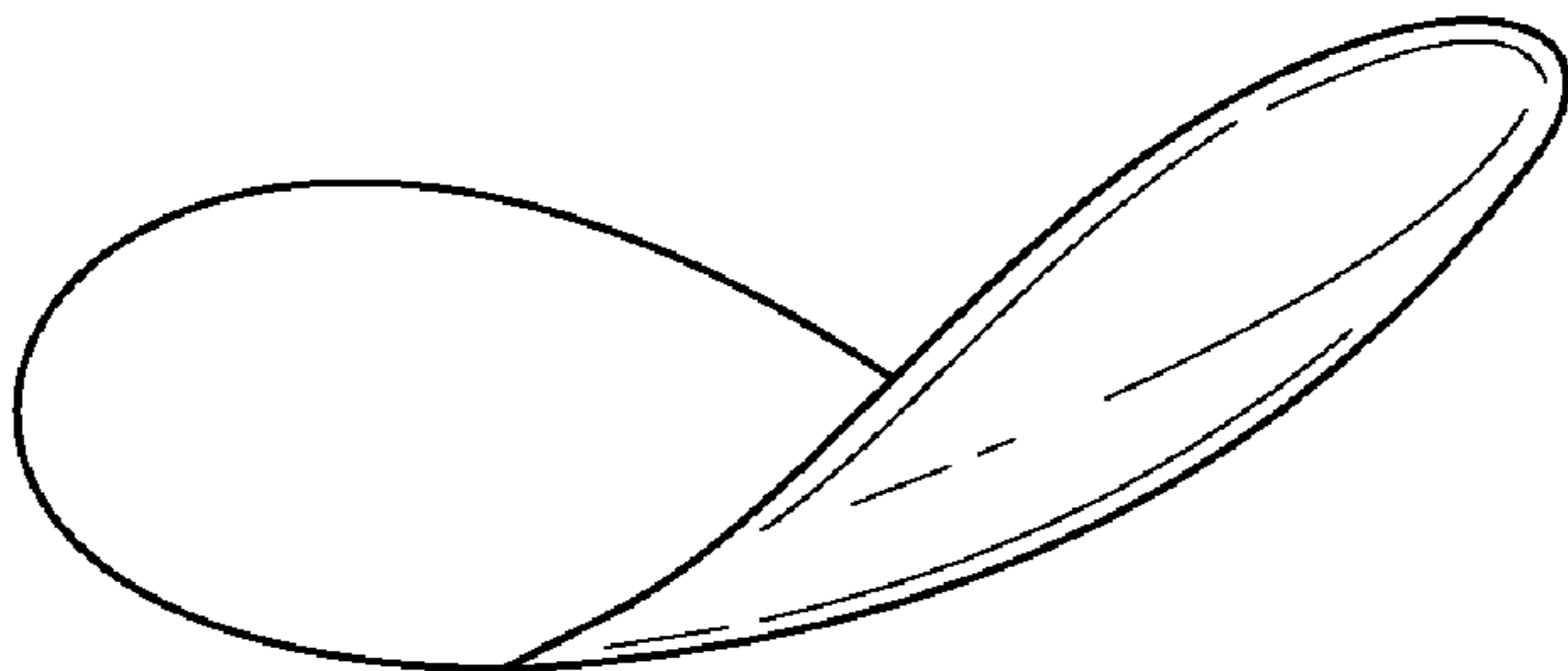



FIG. 1

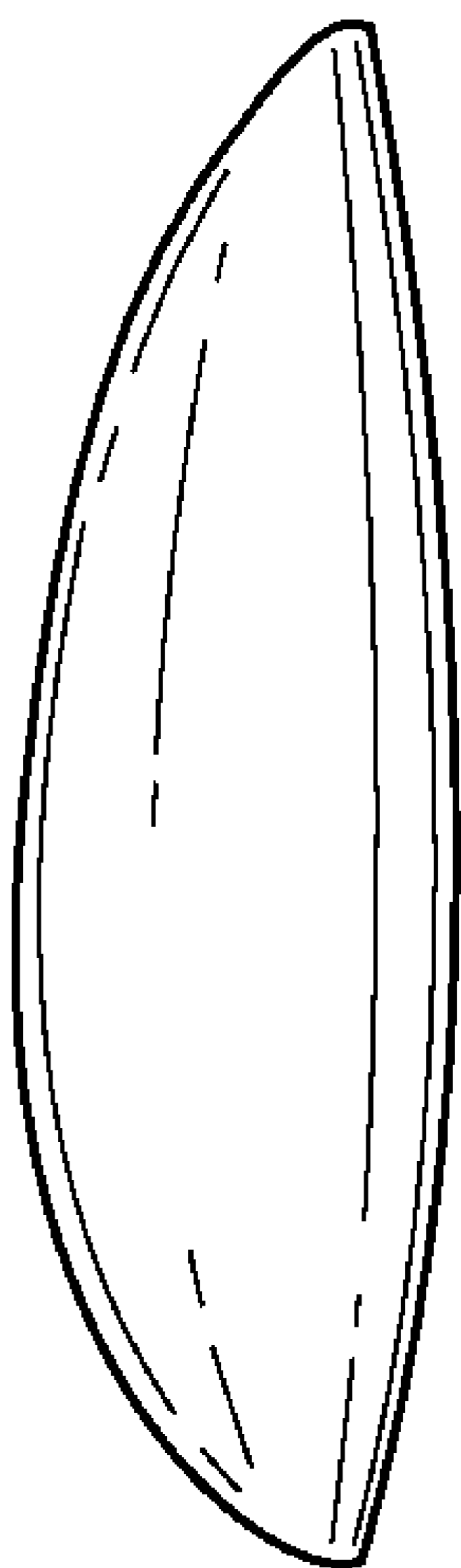

FIG. 2

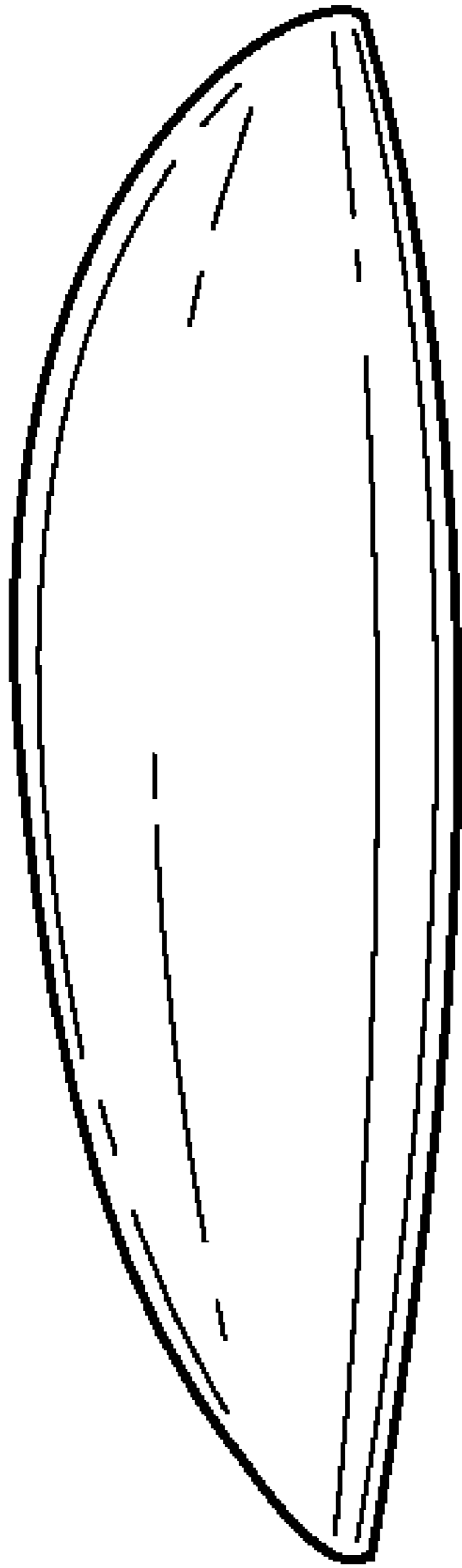

FIG. 3

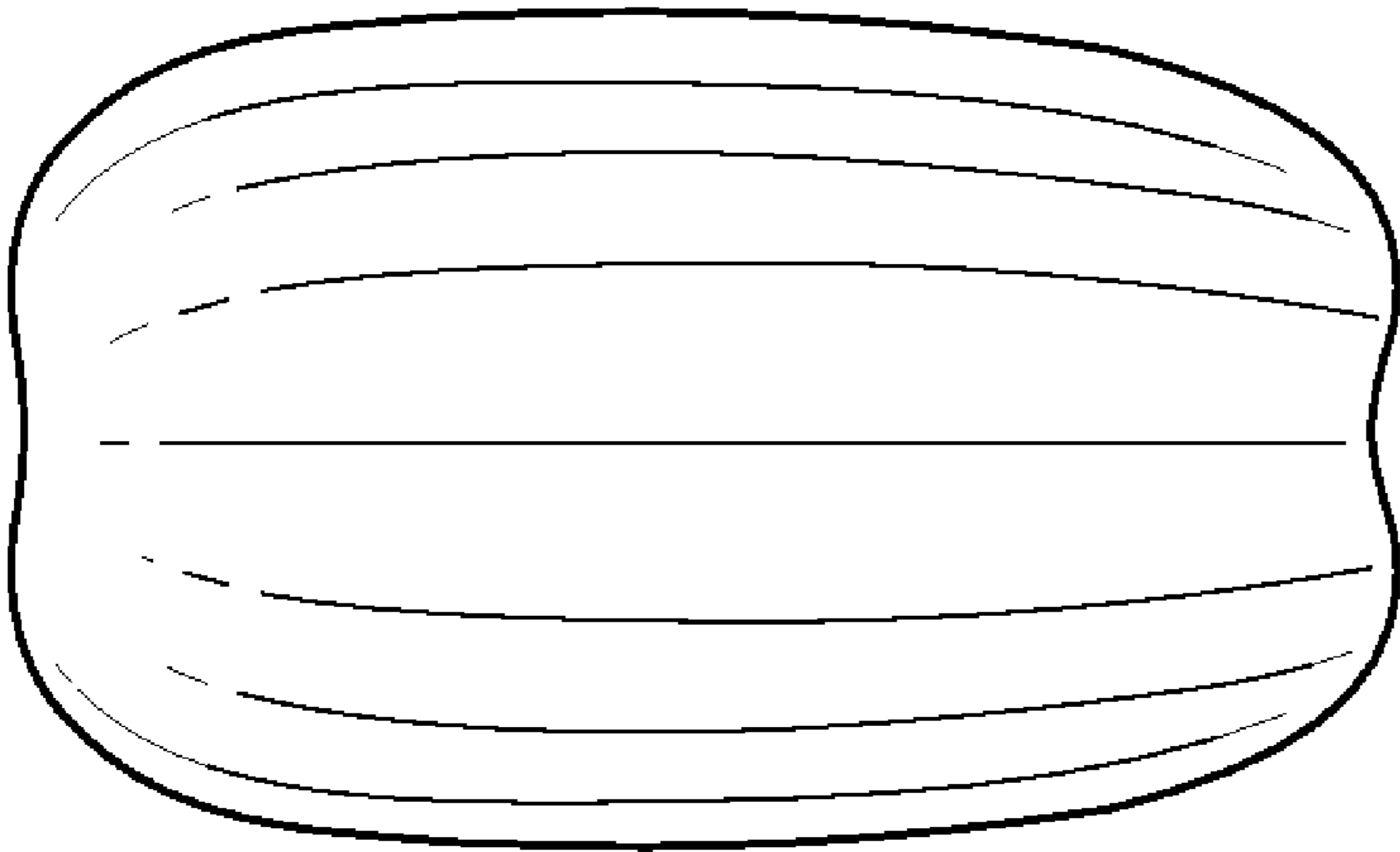

FIG. 4

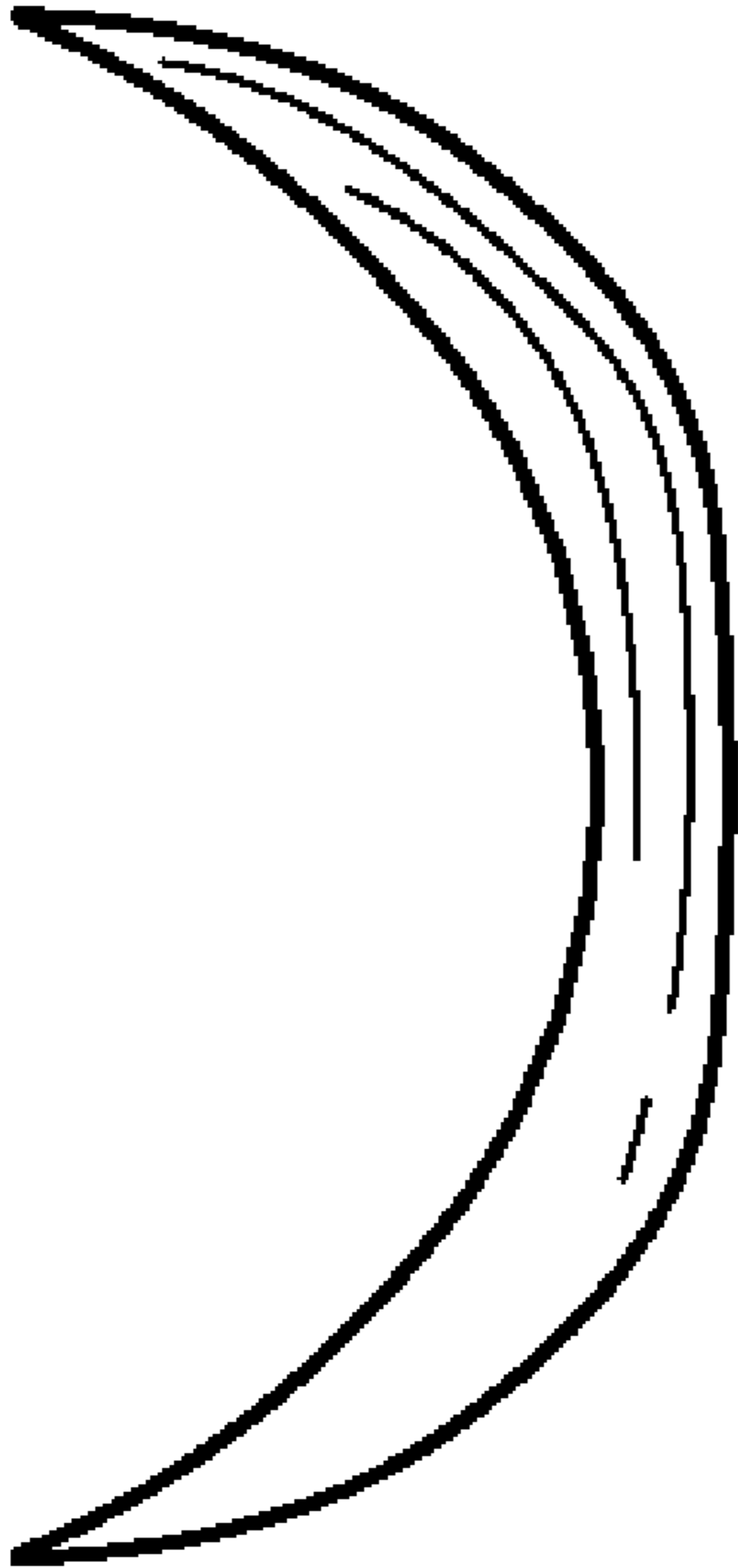

FIG. 5

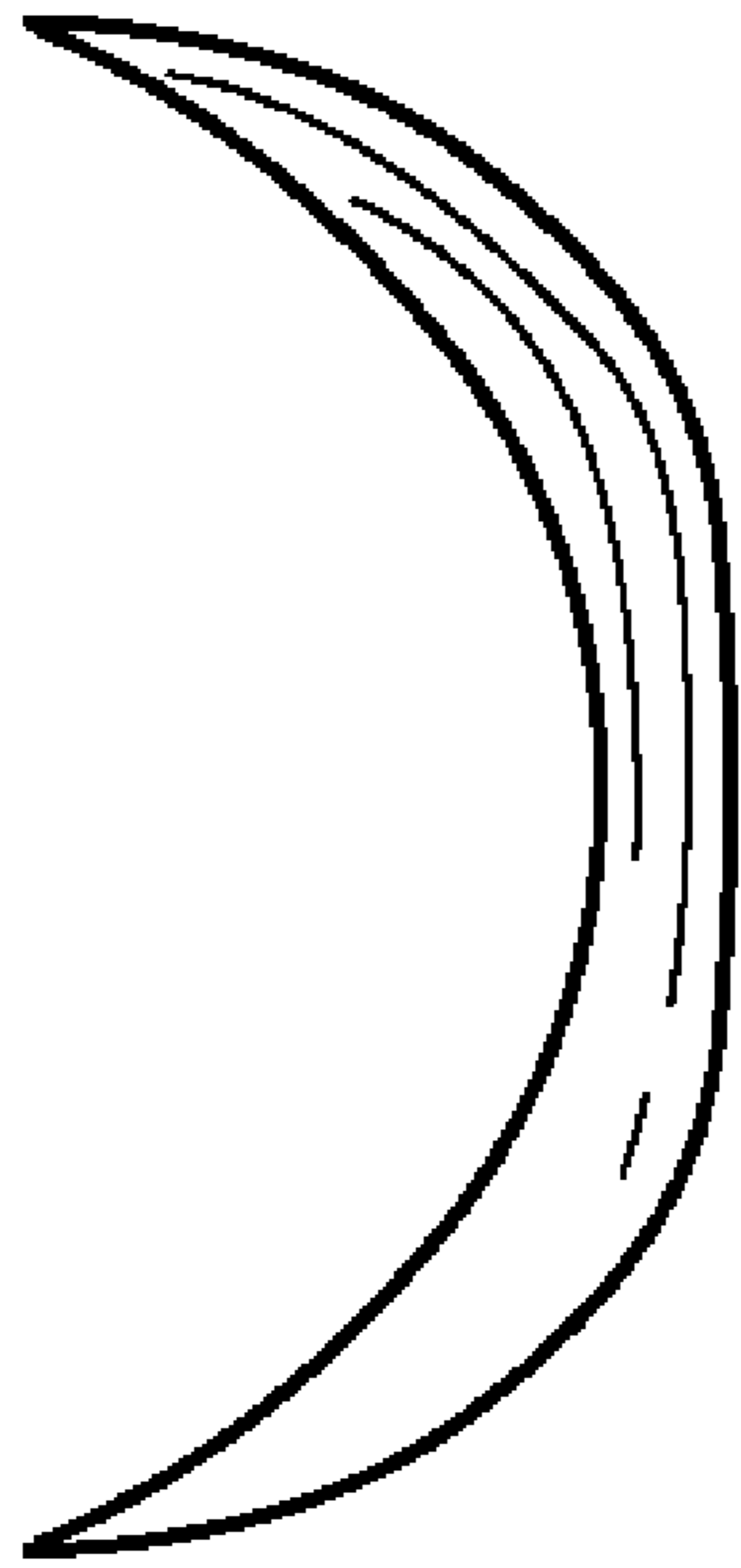

FIG. 6



FIG. 7

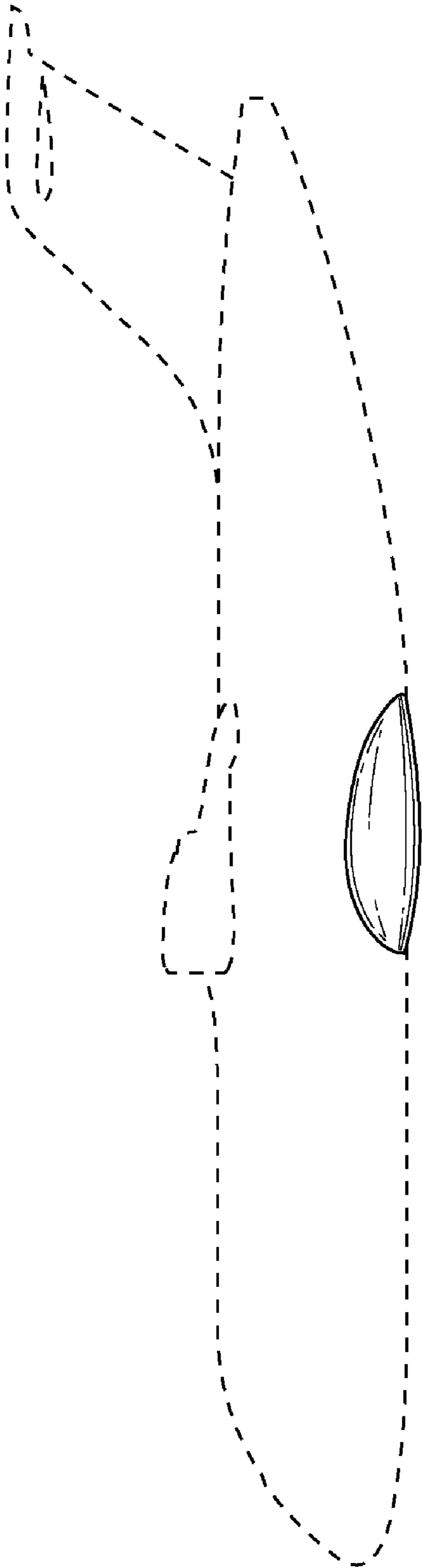

FIG. 8

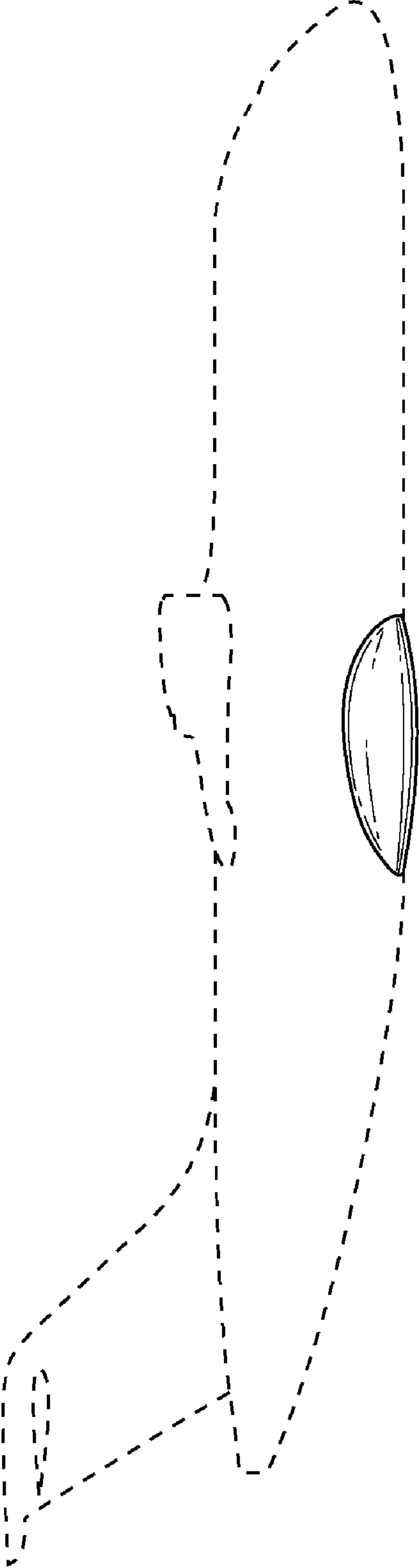

FIG. 9

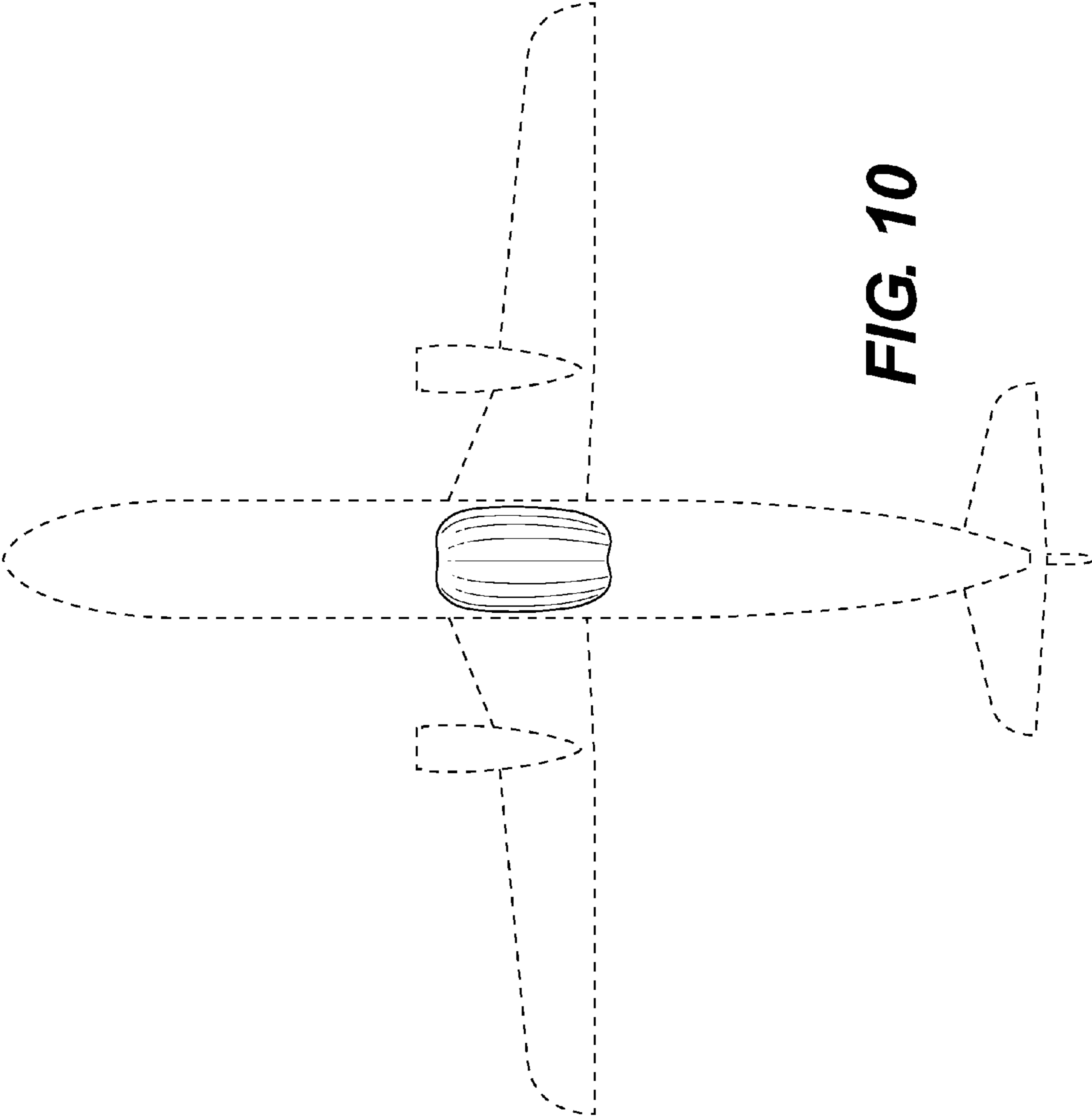

FIG. 10

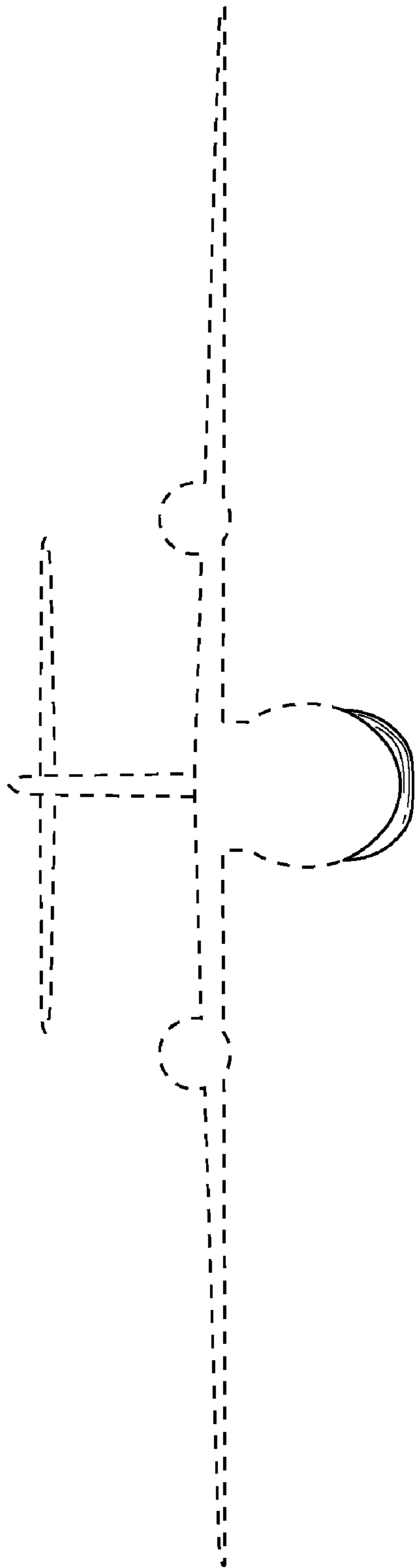

FIG. 11

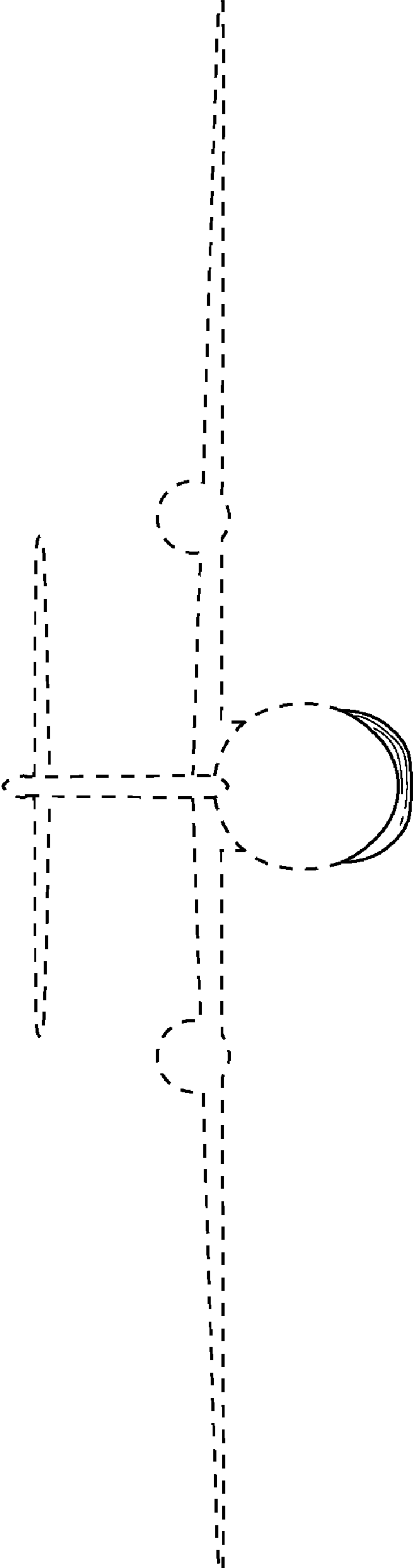

FIG. 12