



US00D623849S

(12) **United States Design Patent**
Chorazewitz et al.

(10) **Patent No.:** **US D623,849 S**

(45) **Date of Patent:** **** Sep. 21, 2010**

(54) **BOTTLE DOCKER**

* cited by examiner

(76) Inventors: **Steven D. Chorazewitz**, 25019 Arden Park Dr., Farmington Hills, MI (US) 48336; **Cheryl M. Chorazewitz**, 25019 Arden Park Dr., Farmington Hills, MI (US) 48336

Primary Examiner—Catherine R Oliver
(74) *Attorney, Agent, or Firm*—Kohn & Associates, PLLC

(57) **CLAIM**

The ornamental design for a bottle docker, as shown and described.

(**) Term: **14 Years**

(21) Appl. No.: **29/341,886**

DESCRIPTION

(22) Filed: **Aug. 14, 2009**

(51) **LOC (9) Cl.** **03-01**

(52) **U.S. Cl.** **D3/215**

(58) **Field of Classification Search** D3/215,
D3/229; D8/356, 371, 394–396; 224/148.1,
224/148.4; 248/312; D19/56, 65
See application file for complete search history.

FIG. 1 is a perspective view of the bottle docker with a bottle being held in broken lines;

FIG. 2 is a front view of the bottle docker;

FIG. 3 is a side view of the bottle docker;

FIG. 4 is a top view of the bottle docker;

FIG. 5 is rear view of the bottle docker;

FIG. 6 is a side view of the bottle docker;

FIG. 7 is a bottom view of the bottle docker; and,

FIG. 8 is a perspective view of the bottle docker.

Any broken line illustration of environmental structure in the drawings is not part of the design sought to be patented.

(56) **References Cited**

U.S. PATENT DOCUMENTS

D404,643 S *	1/1999	Walker	D3/215
6,857,544 B2 *	2/2005	Dahl	224/148.4
6,880,714 B2 *	4/2005	Blanchester	224/148.4
D600,545 S *	9/2009	Quach	D3/215

1 Claim, 3 Drawing Sheets

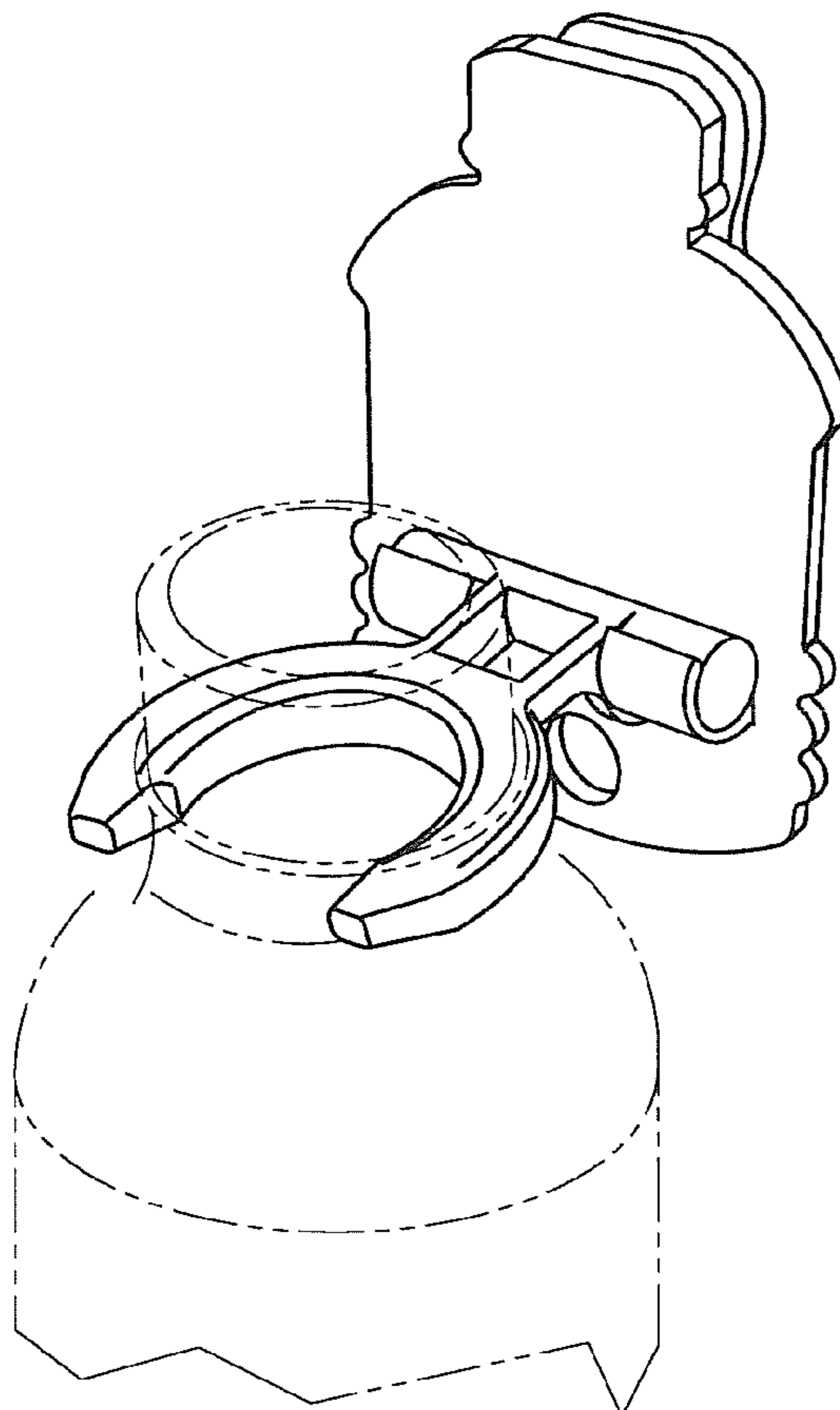

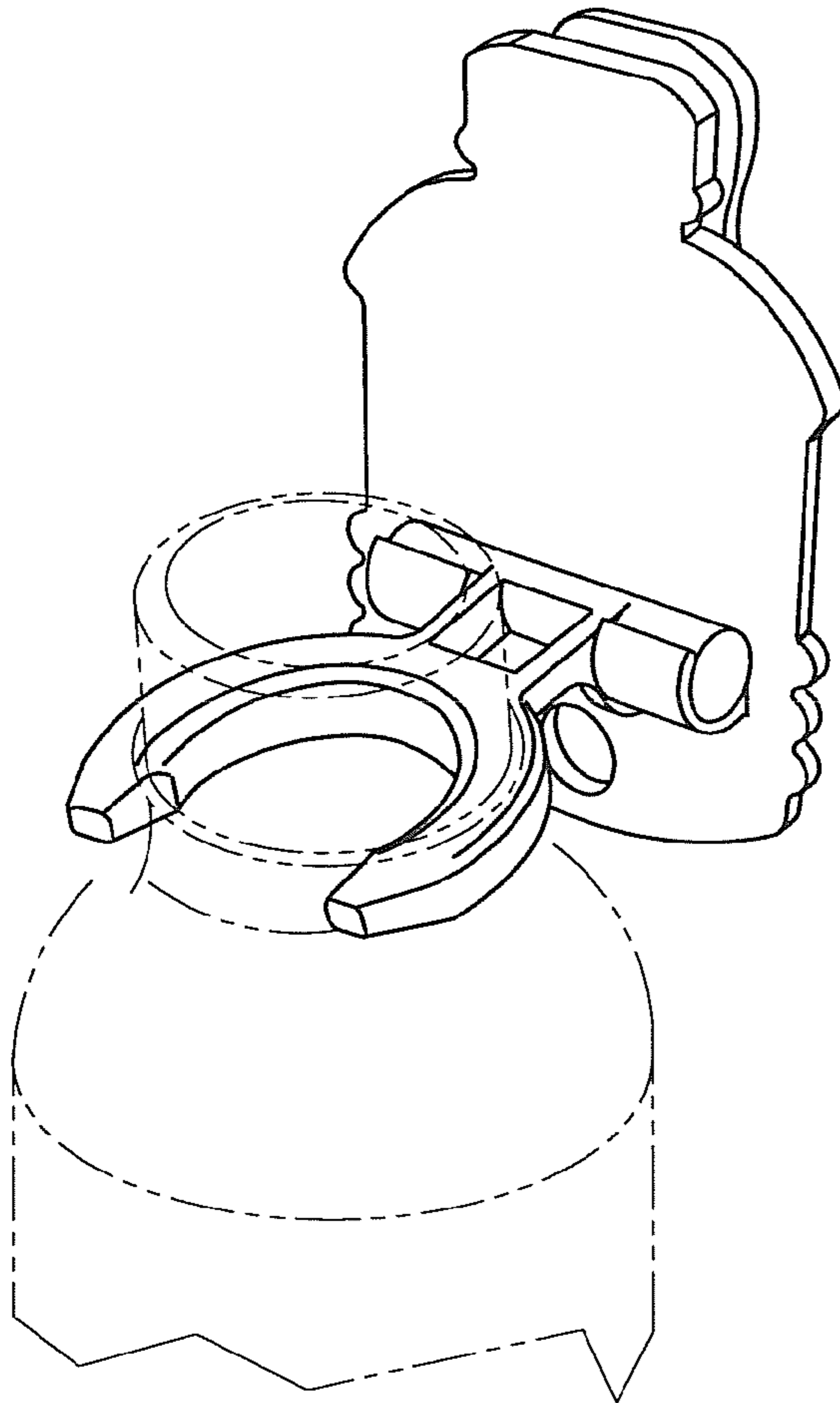

FIG - 1

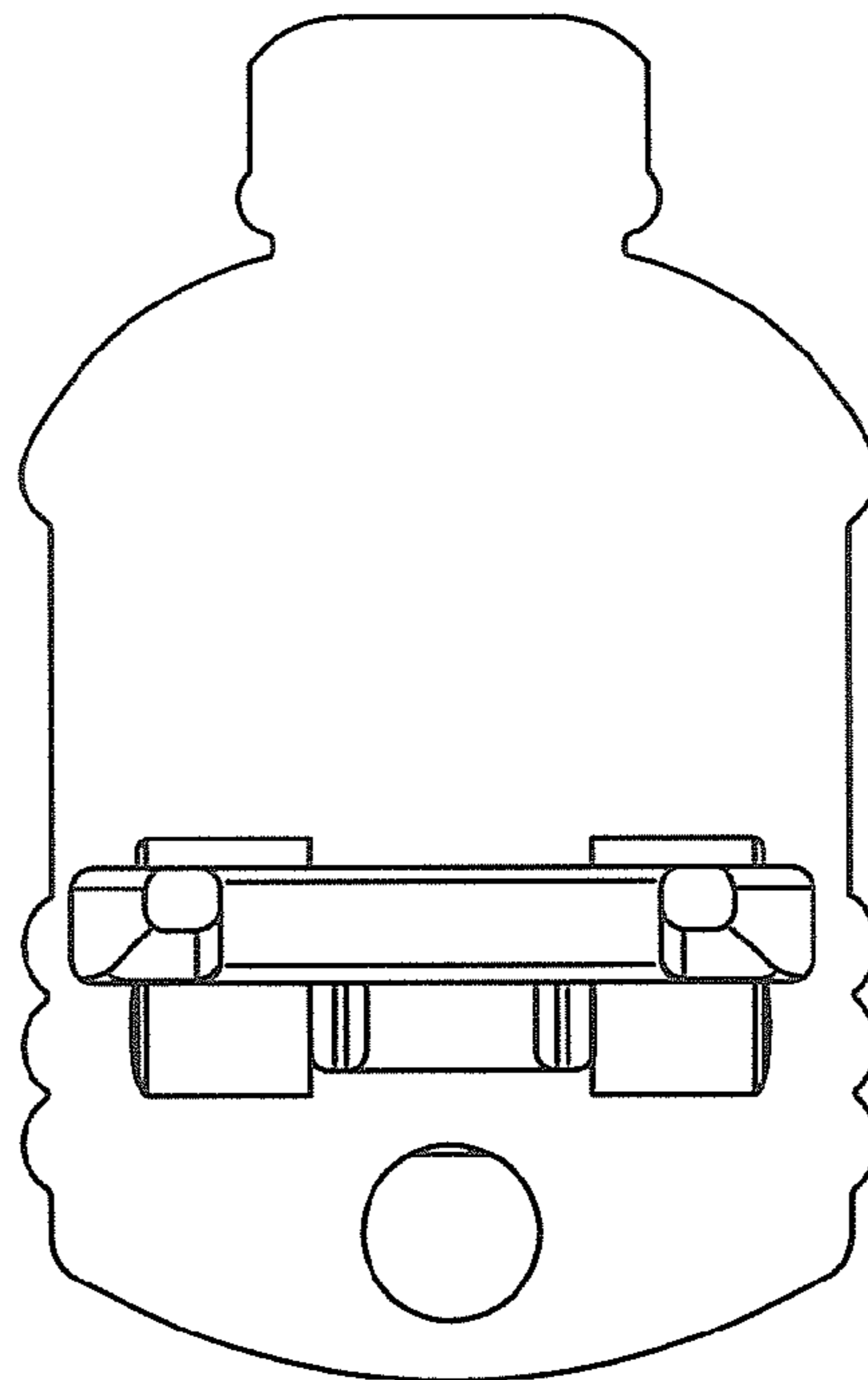

FIG - 2

