



US00D623585S

(12) **United States Design Patent**  
**Giddens**

(10) **Patent No.:** **US D623,585 S**

(45) **Date of Patent:** **\*\* Sep. 14, 2010**

(54) **CARGO BOX LID WITH DOUBLE BEVEL EDGE**

(75) Inventor: **Jimmy Giddens**, Perry, FL (US)

(73) Assignee: **Thule Sweden AB**, Hillerstorp (SE)

(\*\*) Term: **14 Years**

(21) Appl. No.: **29/346,361**

(22) Filed: **Oct. 30, 2009**

(51) **LOC (9) Cl.** ..... **12-99**

(52) **U.S. Cl.** ..... **D12/414.1**

(58) **Field of Classification Search** ..... D12/401-414,  
D12/414.1, 89-93, 16, 96-100; D21/433-434,  
D21/548, 552, 559, 561; D25/38, 43; D6/552,  
D6/513, 567; 135/88.01, 95; 150/165-167,  
150/158; 160/32, 26; 280/770; 296/136.01,  
296/190.08, 190.01-190.02, 114-116, 77.1,  
296/100.01-100.06, 98

See application file for complete search history.

(56) **References Cited**

**U.S. PATENT DOCUMENTS**

3,737,058	A *	6/1973	Johnson	.....	414/537
D259,413	S *	6/1981	Rehkopf	.....	D12/414.1
4,295,481	A *	10/1981	Gee	.....	52/64
D356,200	S *	3/1995	Kern et al.	.....	D34/27
D370,452	S *	6/1996	Beasley	.....	D12/203
5,676,292	A *	10/1997	Miller	.....	224/524
D594,259	S *	6/2009	Swedberg et al.	.....	D6/513
2004/0238087	A1 *	12/2004	Ciapessoni	.....	150/158

\* cited by examiner

*Primary Examiner*—Caron Veynar  
*Assistant Examiner*—Katrina A Kile

(74) *Attorney, Agent, or Firm*—Novak Druce + Quigg LLP

(57) **CLAIM**

I claim the ornamental design for a cargo box lid with double bevel edge, as shown and described.

**DESCRIPTION**

FIG. 1 is an upper perspective view of a cargo box lid with double bevel edge;

FIG. 2 is a front elevational view thereof;

FIG. 3 is a left side elevational view thereof;

FIG. 4 is a top plan view thereof;

FIG. 5 is a bottom plan view thereof;

FIG. 6 is a lower perspective view thereof;

FIG. 7 is a close up view of a portion of the left side view of the design as shown in FIG. 3; and,

FIG. 8 is a close up view of a portion of the upper perspective view of the design shown in FIG. 1.

The right side of the design is a mirror image of left side, and is therefore not shown. The back of the design is a mirror image of the front, and is therefore not shown. The corners of the design, shown in detail in FIGS. 7 and 8, are all the same.

In the drawings, the evenly spaced broken lines in FIGS. 1, 2, 5 and 6 depict portions of a cargo box with double bevel edge that form no part of the claimed design. The dot dot dash broken line in FIGS. 5 and 6 represent the boundary of the claim and form no part of the claimed design.

**1 Claim, 6 Drawing Sheets**

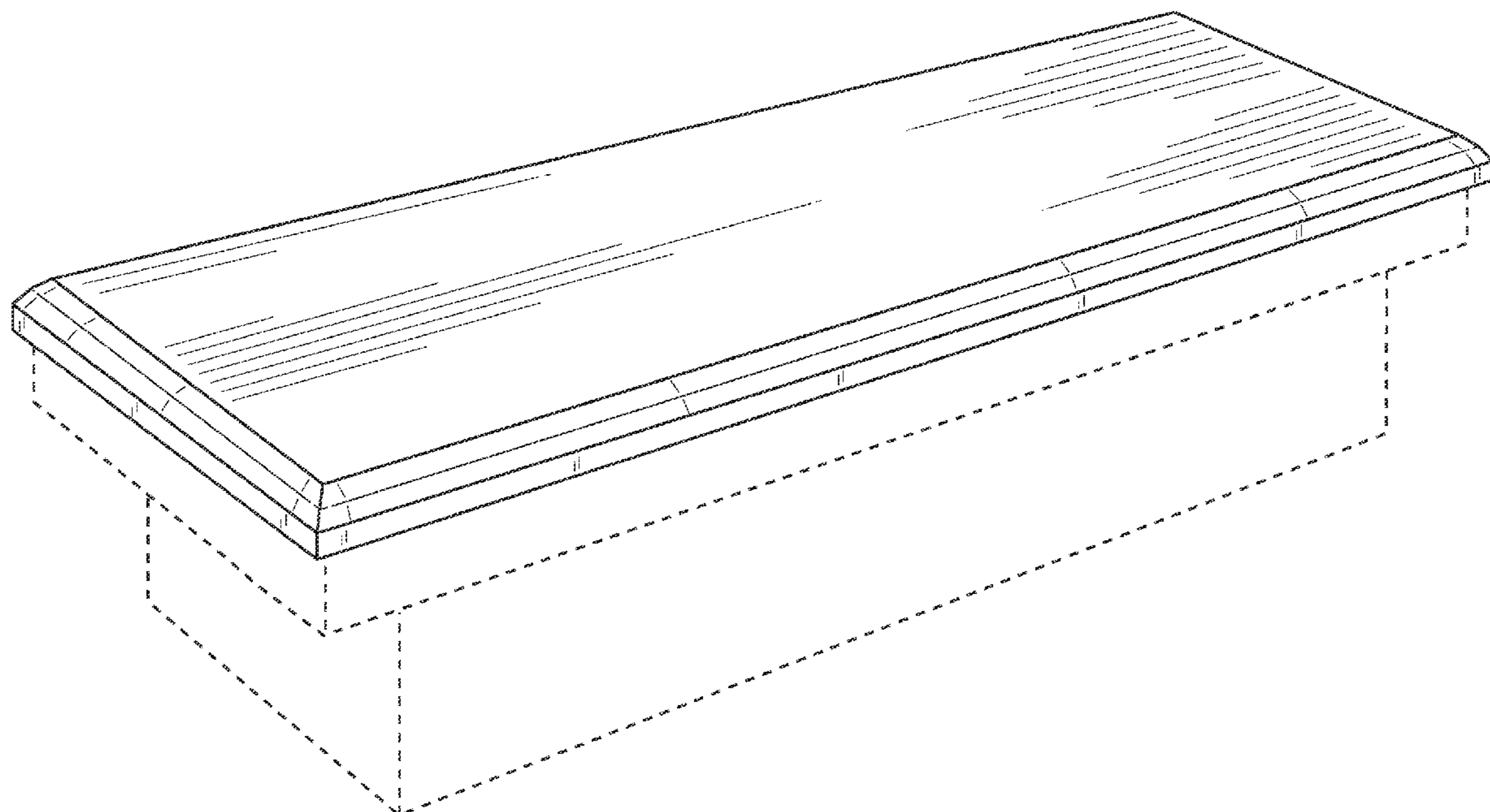

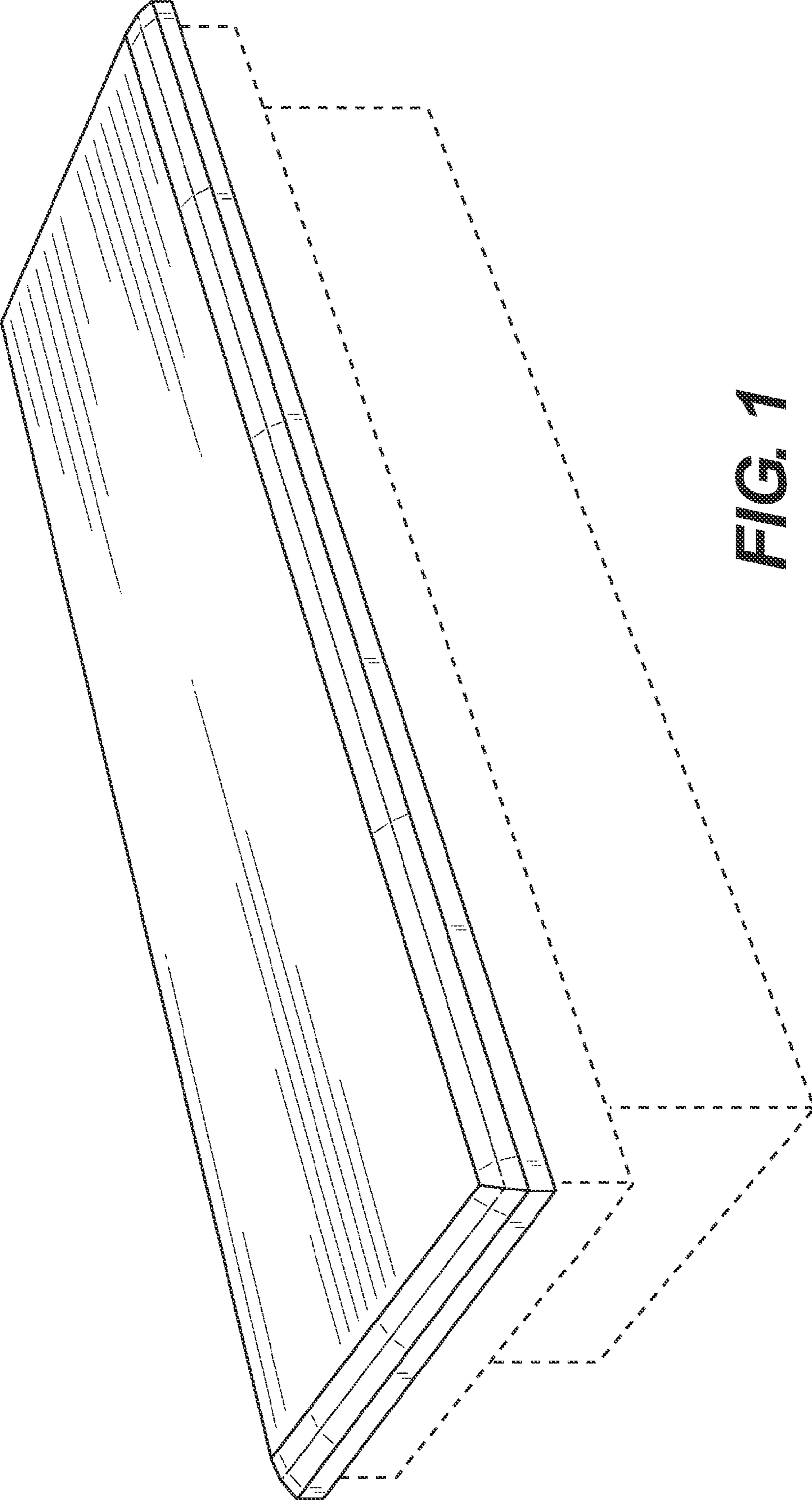
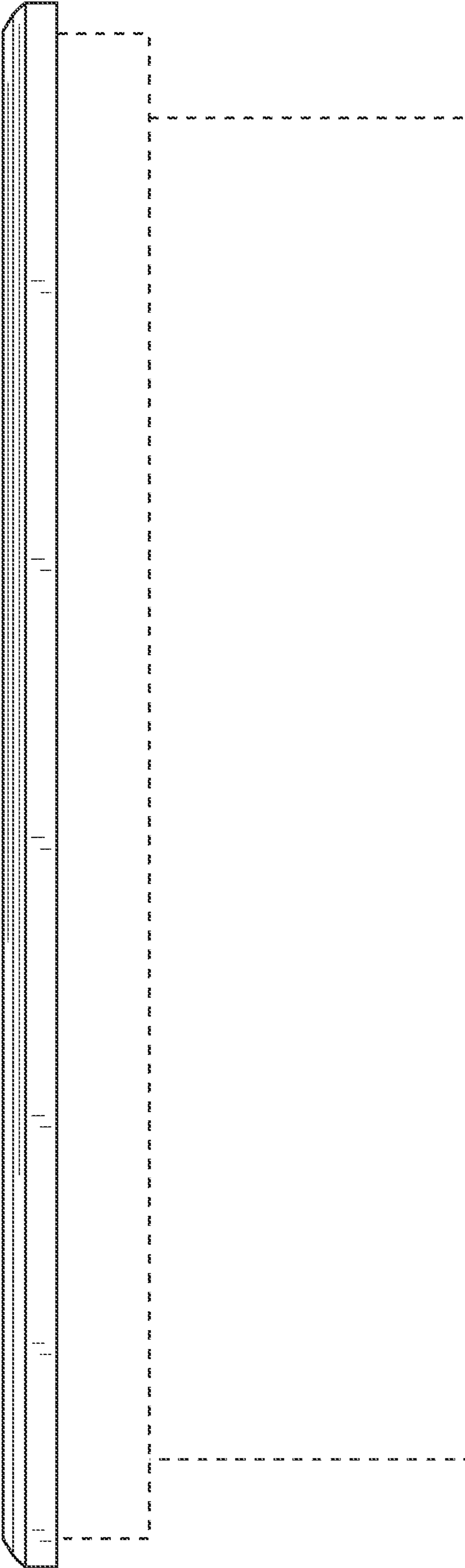
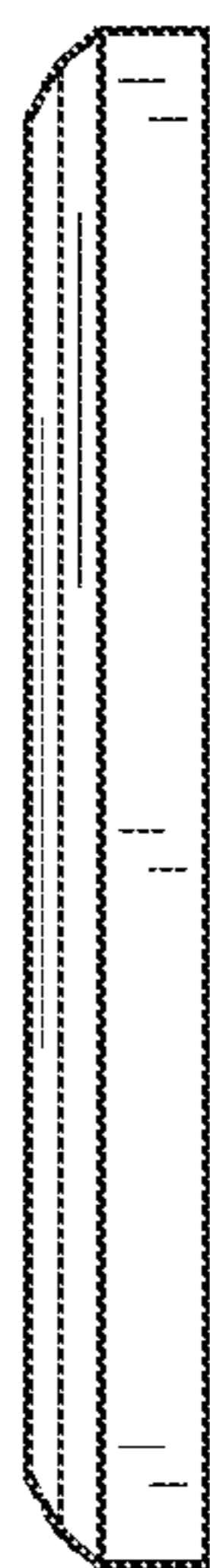

FIG. 1



**FIG. 2**



**FIG. 3**

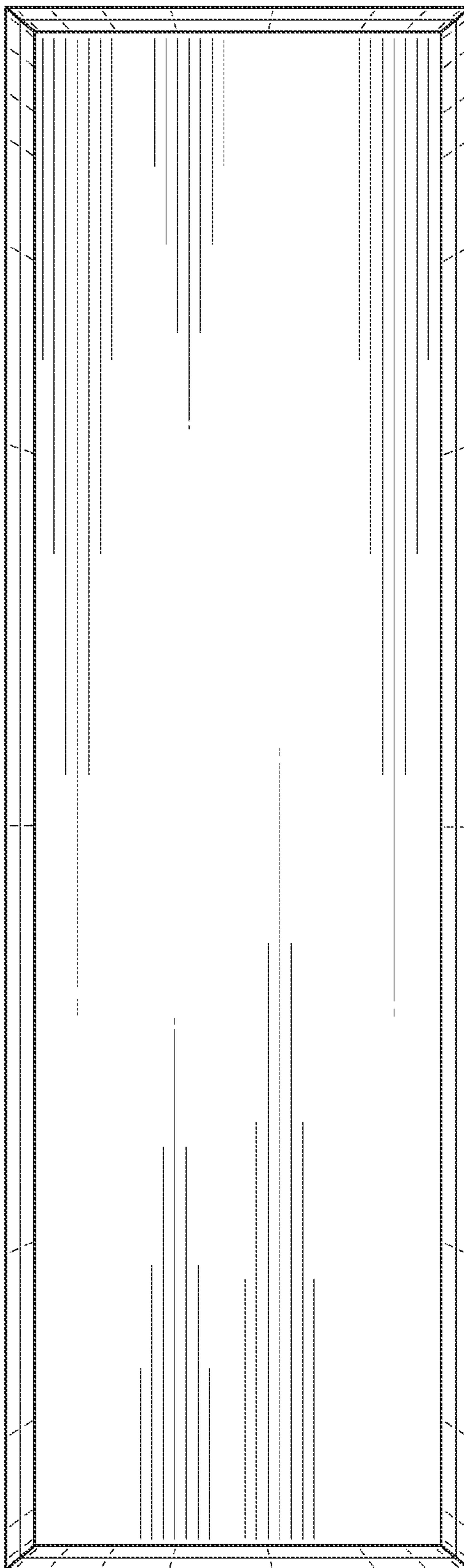

**FIG. 4**

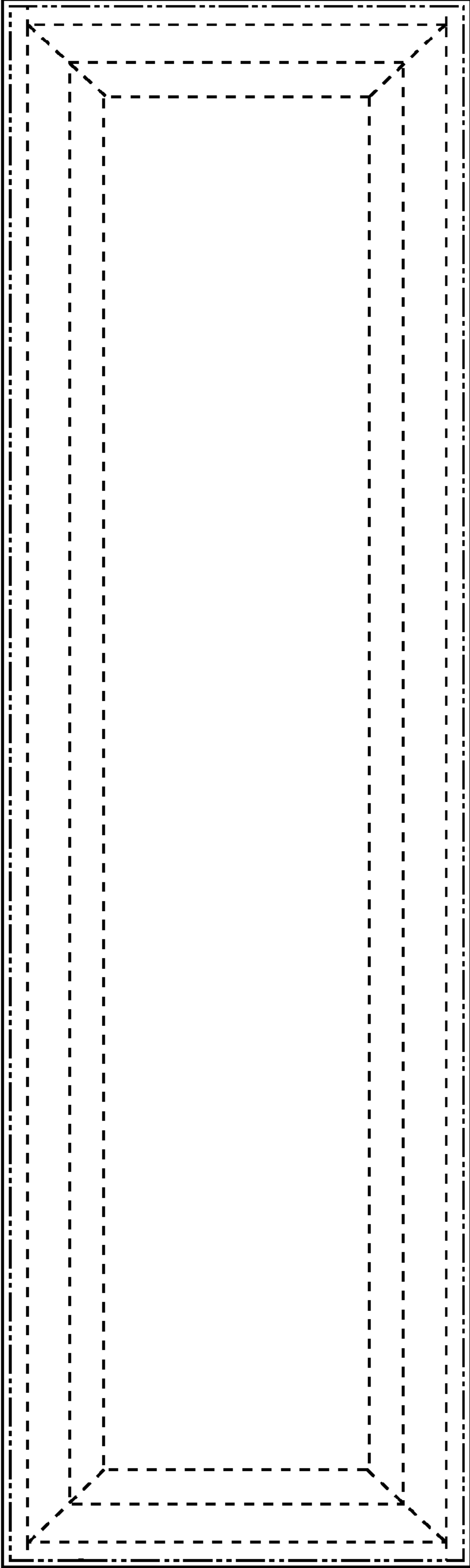

**FIG. 5**

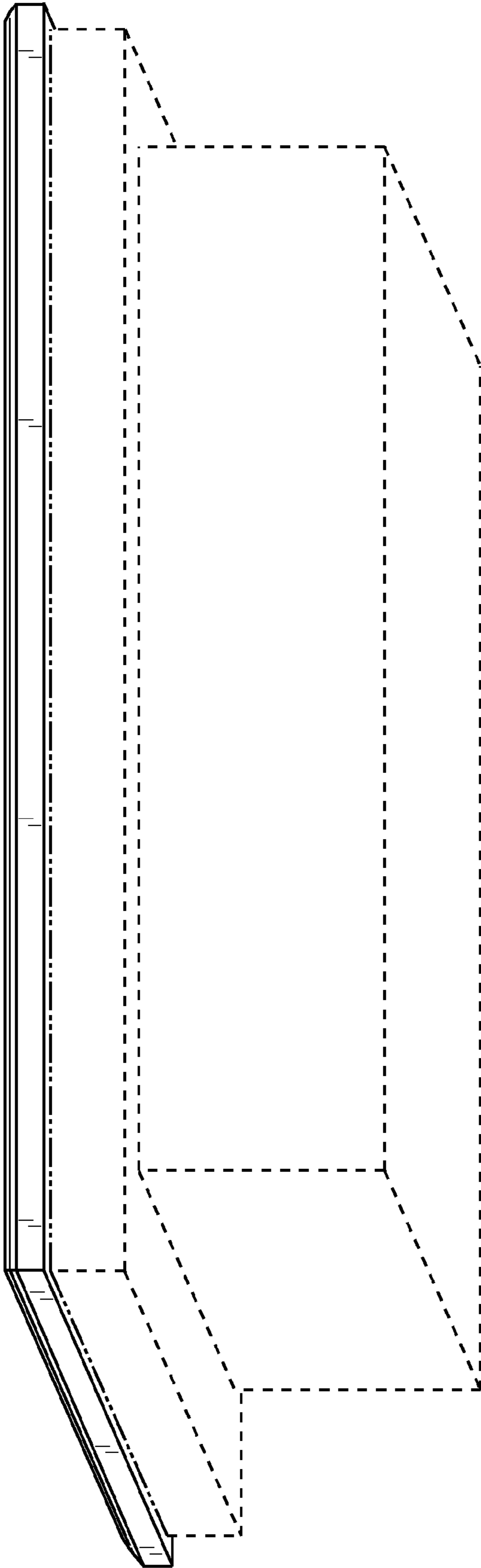

**FIG. 6**

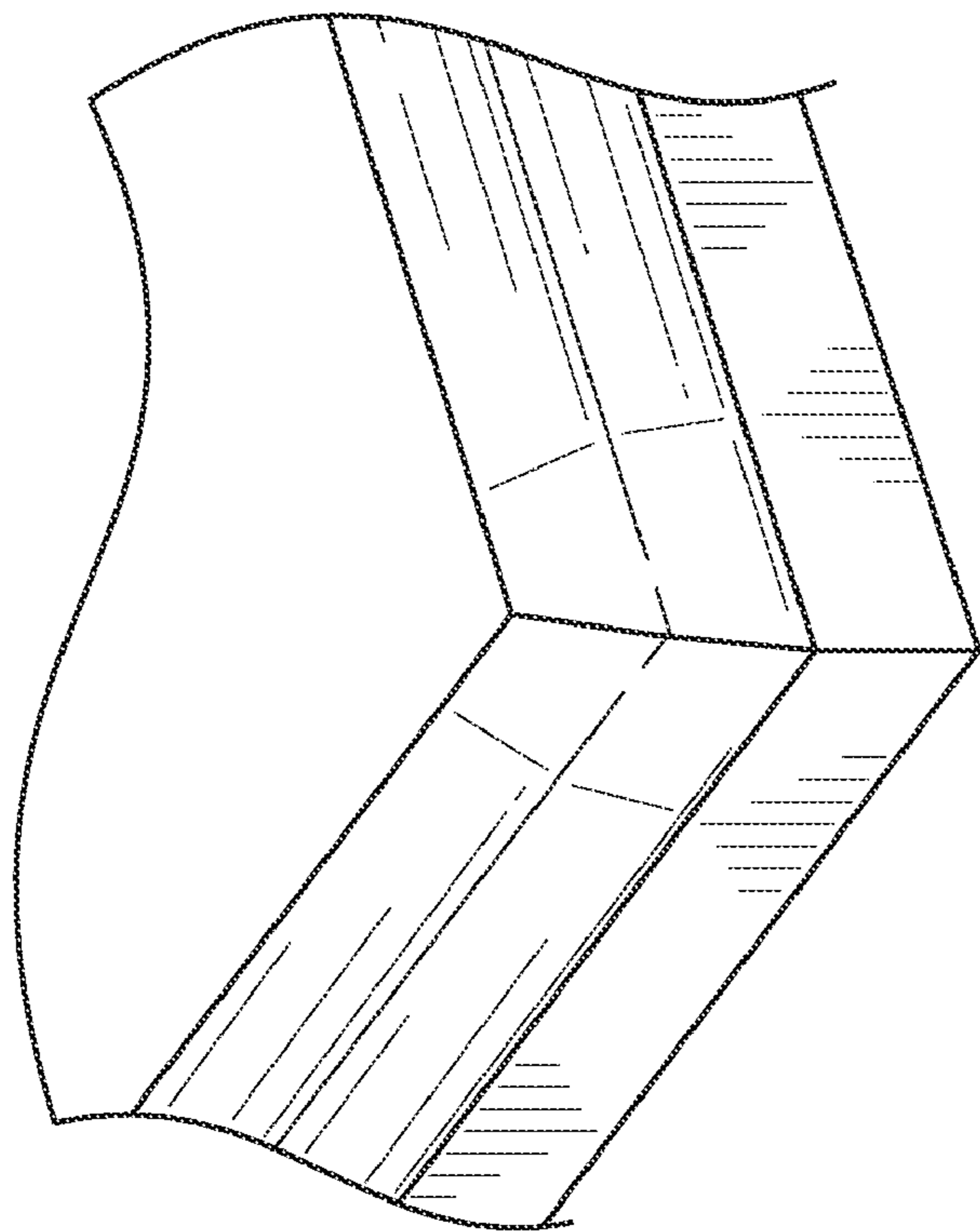

**FIG. 8**

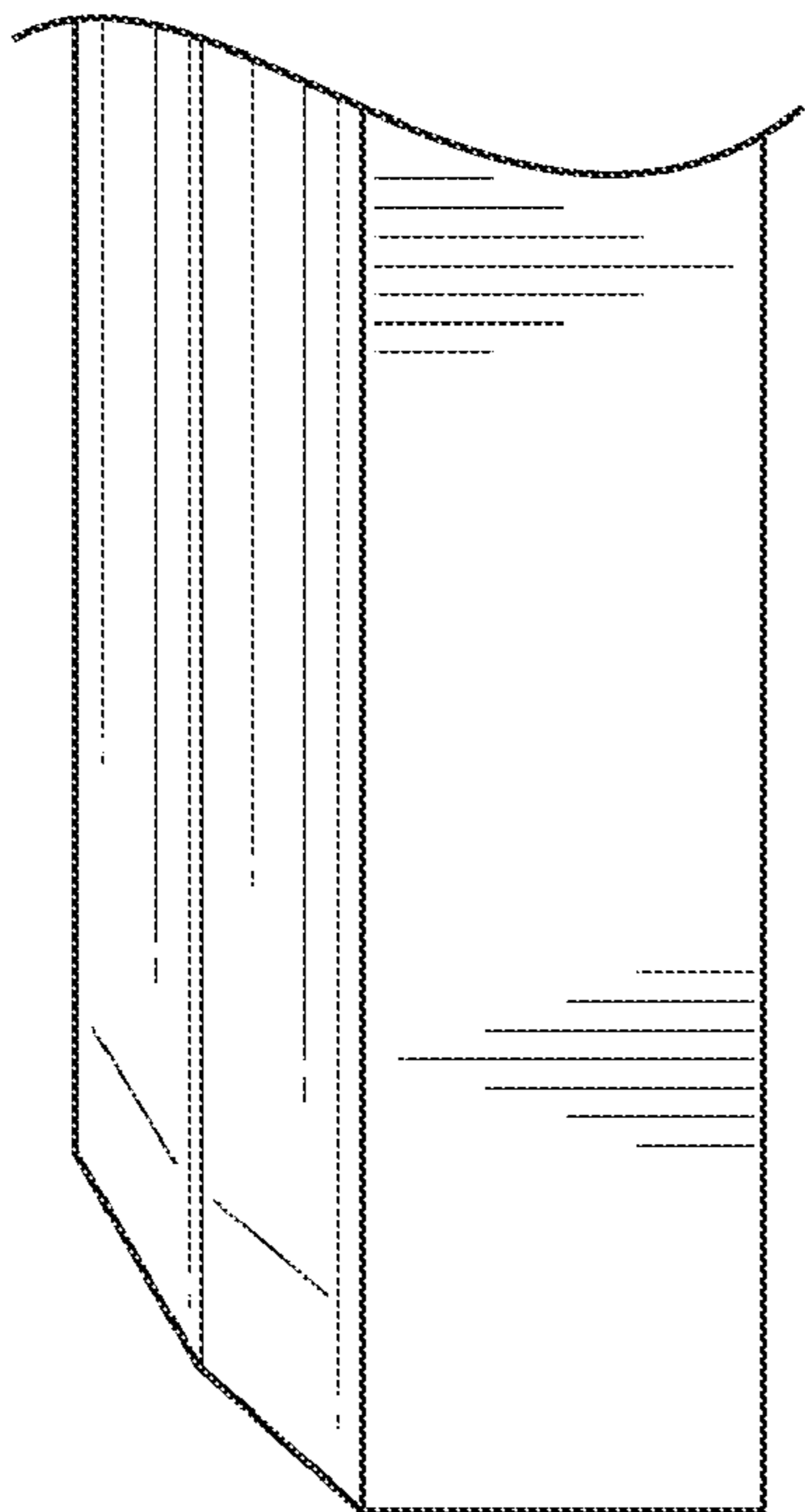

**FIG. 7**