



US00D623583S

(12) **United States Design Patent**  
**Girardi**

(10) **Patent No.:** **US D623,583 S**

(45) **Date of Patent:** **\*\* \*Sep. 14, 2010**

(54) **TOP FOR PICKUP TRUCK**

(75) Inventor: **Levi Girardi**, Sao Paulo (BR)

(73) Assignee: **Estacio Terui**, Sorocaba, Sao Paulo (BR)

(\*\*) Term: **14 Years**

(21) Appl. No.: **29/339,184**

(22) Filed: **Jun. 25, 2009**

(51) **LOC (9) Cl.** ..... **12-16**

(52) **U.S. Cl.** ..... **D12/404**

(58) **Field of Classification Search** ..... D12/400,  
D12/401, 404, 406, 412, 414, 222, 223, 86,  
D12/93, 101; 224/923, 924; 211/10, 124,  
211/2, 4, 85.7; D6/552

See application file for complete search history.

(56) **References Cited**

**U.S. PATENT DOCUMENTS**

D281,488 S *	11/1985	Collins	.....	D12/404
D304,436 S *	11/1989	Pike	.....	D12/404
D324,015 S *	2/1992	Quiniones	.....	D12/404
D324,196 S *	2/1992	Muth	.....	D12/404
D383,432 S *	9/1997	Starr et al.	.....	D12/404
D387,029 S *	12/1997	Heinemann	.....	D12/404
D403,652 S *	1/1999	Starr et al.	.....	D12/404
D432,074 S *	10/2000	Harris	.....	D12/404
D444,445 S *	7/2001	Schroeder	.....	D12/404
6,468,149 B2 *	10/2002	Essig et al.	.....	454/164
D468,682 S *	1/2003	Soldatelli	.....	D12/404

**OTHER PUBLICATIONS**

<http://allpick-up.com.br/fotos/L.200%/o20Triton.jpg> 2009.

[http://www.totalpickup.com.br/pag\\_inicio/capotas/sei\\_06.jpg](http://www.totalpickup.com.br/pag_inicio/capotas/sei_06.jpg) 2009.

[http://www.totalpickup.com.br/pag\\_inicio/capotas/sel\\_04.jpg](http://www.totalpickup.com.br/pag_inicio/capotas/sel_04.jpg) 2009.

[http://www.totalpickup.com.br/pag\\_inicio/capotas/sel\\_02.jpg](http://www.totalpickup.com.br/pag_inicio/capotas/sel_02.jpg) 2009.

[http://www.totalpickup.com.br/pag\\_inicio/capotas/cp\\_novo\\_hilux\\_02.jpg](http://www.totalpickup.com.br/pag_inicio/capotas/cp_novo_hilux_02.jpg) 2009.

[http://www.totalpickup.com.br/pag\\_inicio/capotas/cp\\_novo\\_hilux\\_02.jpg](http://www.totalpickup.com.br/pag_inicio/capotas/cp_novo_hilux_02.jpg) 2009.

[http://www.totalpickup.com.br/pag\\_inicio/capotas/cp\\_novo\\_hilux\\_02.jpg](http://www.totalpickup.com.br/pag_inicio/capotas/cp_novo_hilux_02.jpg) 2009.

[http://www.tronador.com.ar/images/productos/ford/ht\\_media\\_puertal.gif](http://www.tronador.com.ar/images/productos/ford/ht_media_puertal.gif) 2009.

[http://www.tronador.com.ar/images/productor/izusu/ht\\_media\\_puertal.gif](http://www.tronador.com.ar/images/productor/izusu/ht_media_puertal.gif) 2009.

(Continued)

*Primary Examiner*—Caron Veynar

*Assistant Examiner*—Katrina A Kile

(74) *Attorney, Agent, or Firm*—Sughrue Mion, PLLC

(57) **CLAIM**

The ornamental design for a top for pickup truck, as shown.

**DESCRIPTION**

FIG. 1 is a top plan view of a top for a pickup truck showing my new design;

FIG. 2 is a front elevation view thereof;

FIG. 3 is a right elevation view thereof, it being understood that the left side is a mirror view thereof;

FIG. 4 is a rear elevation view thereof;

FIG. 5 is a front perspective view of the right side thereof; and,

FIG. 6 is a rear perspective view of the left side thereof.

**1 Claim, 3 Drawing Sheets**

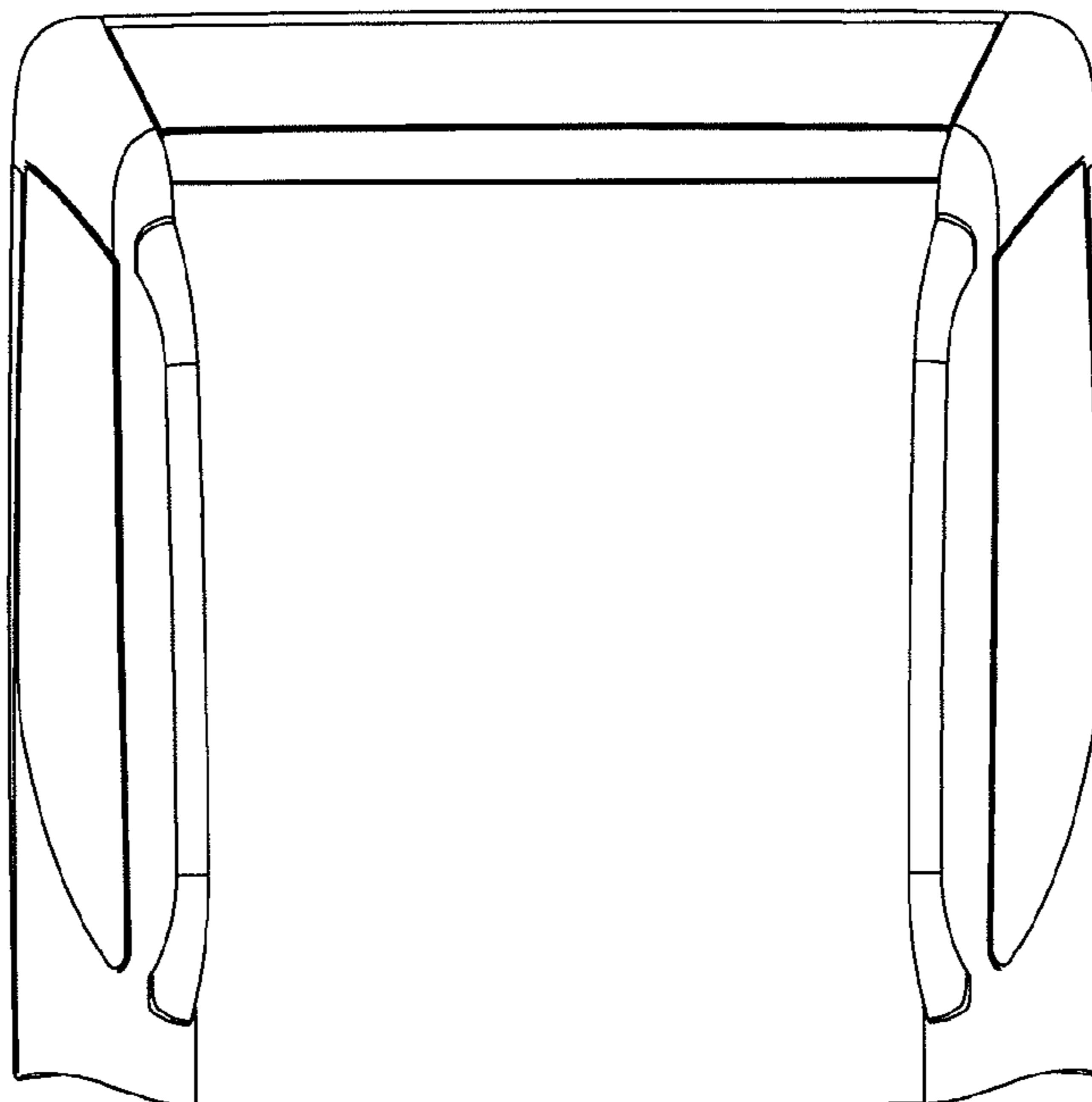

OTHER PUBLICATIONS

[http://www.tronador.com.ar/images/productor/chevorlet/  
ht\\_media\\_puerta.gif](http://www.tronador.com.ar/images/productor/chevorlet/ht_media_puerta.gif) 2009.

<http://www.tronador.com.ar/images/productor/toyota/ht2005.gif>  
2009.

\* cited by examiner

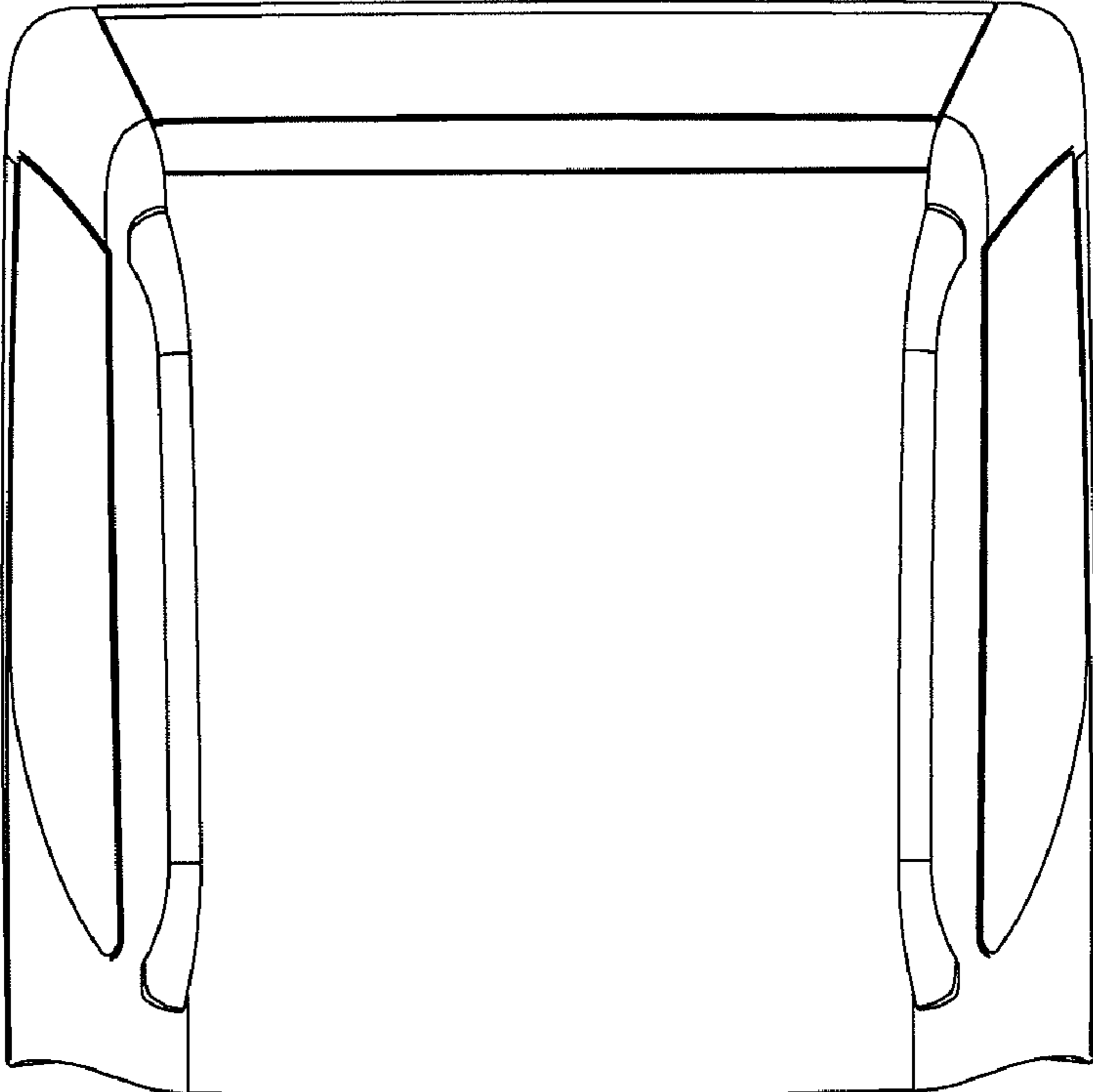

FIG. 1

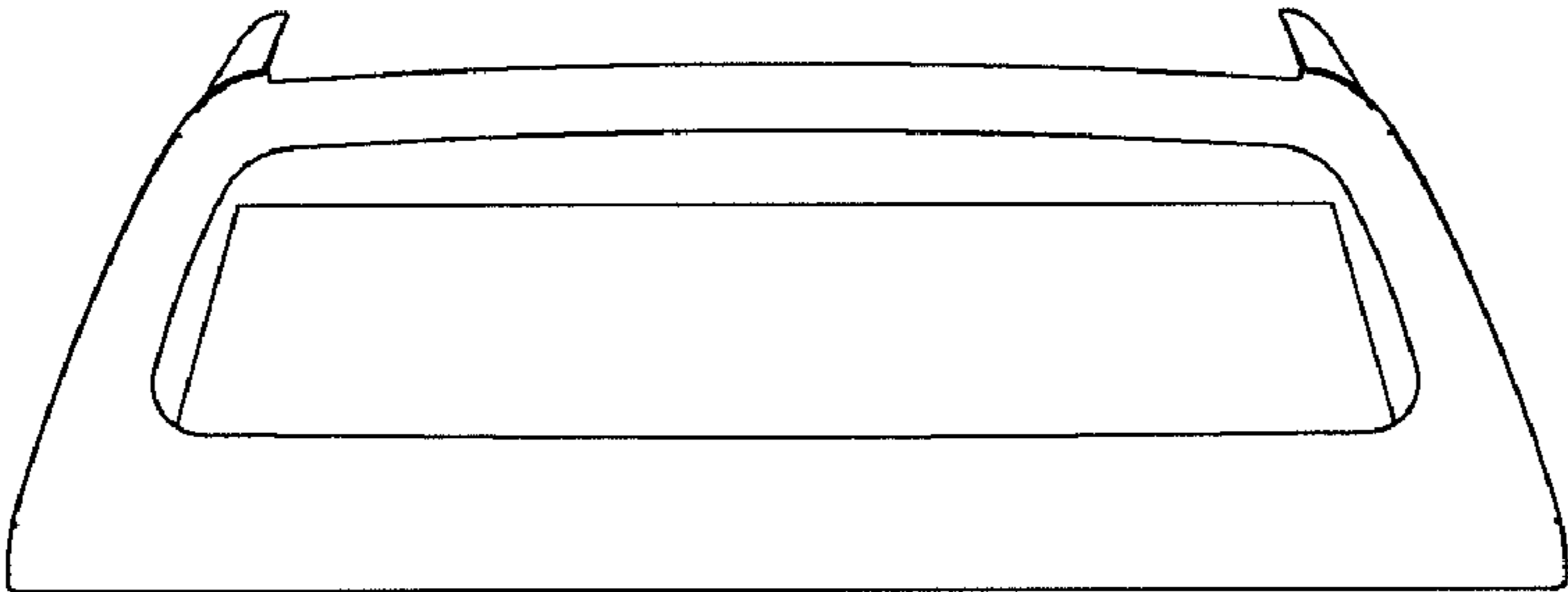
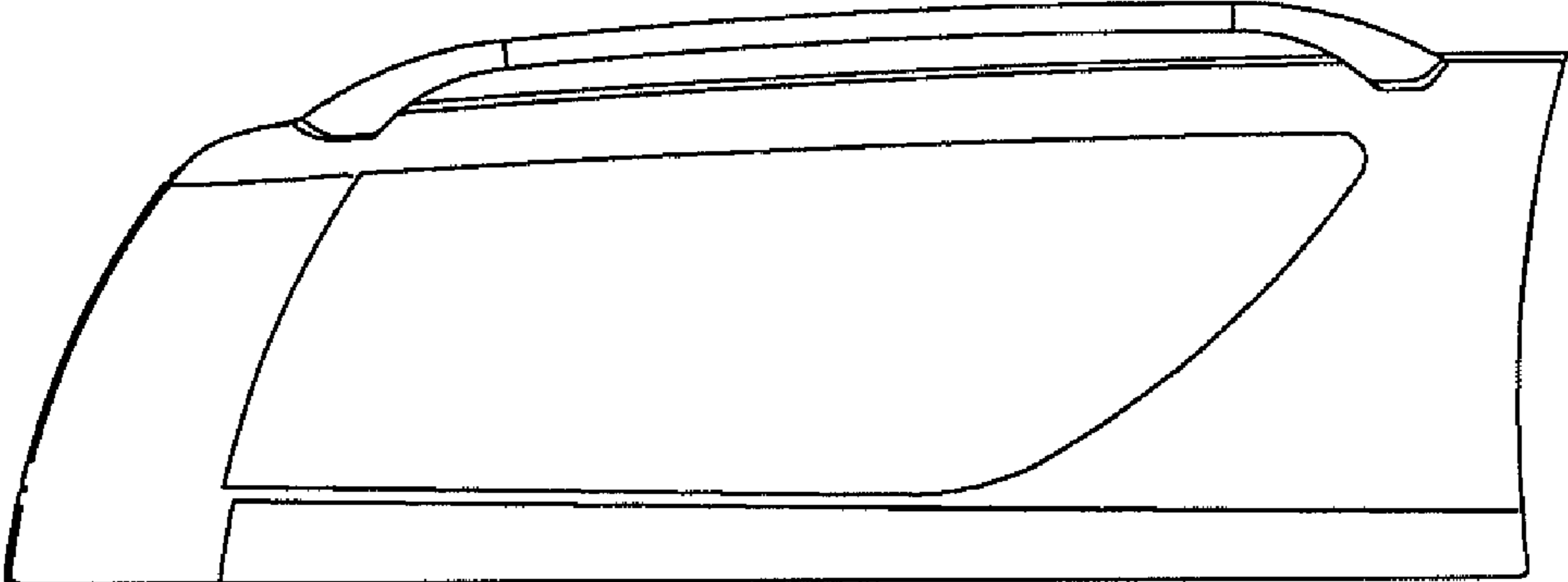
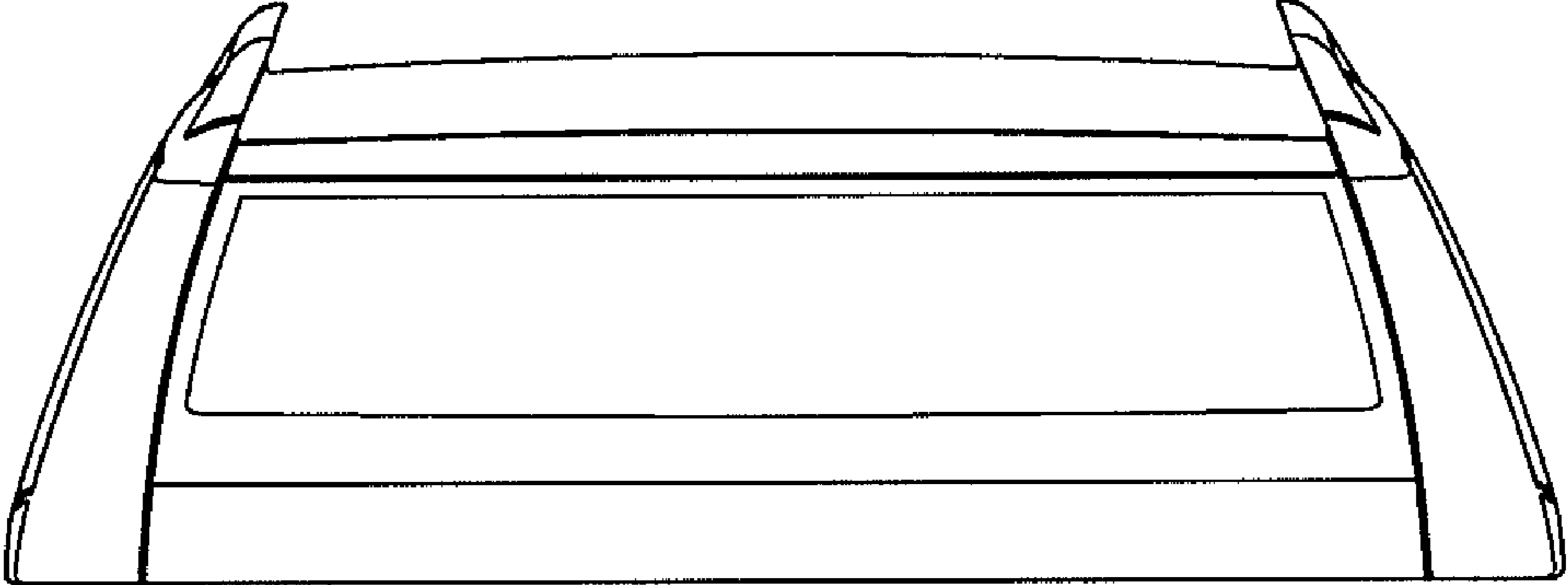

FIG. 2



**FIG. 3**



**FIG. 4**

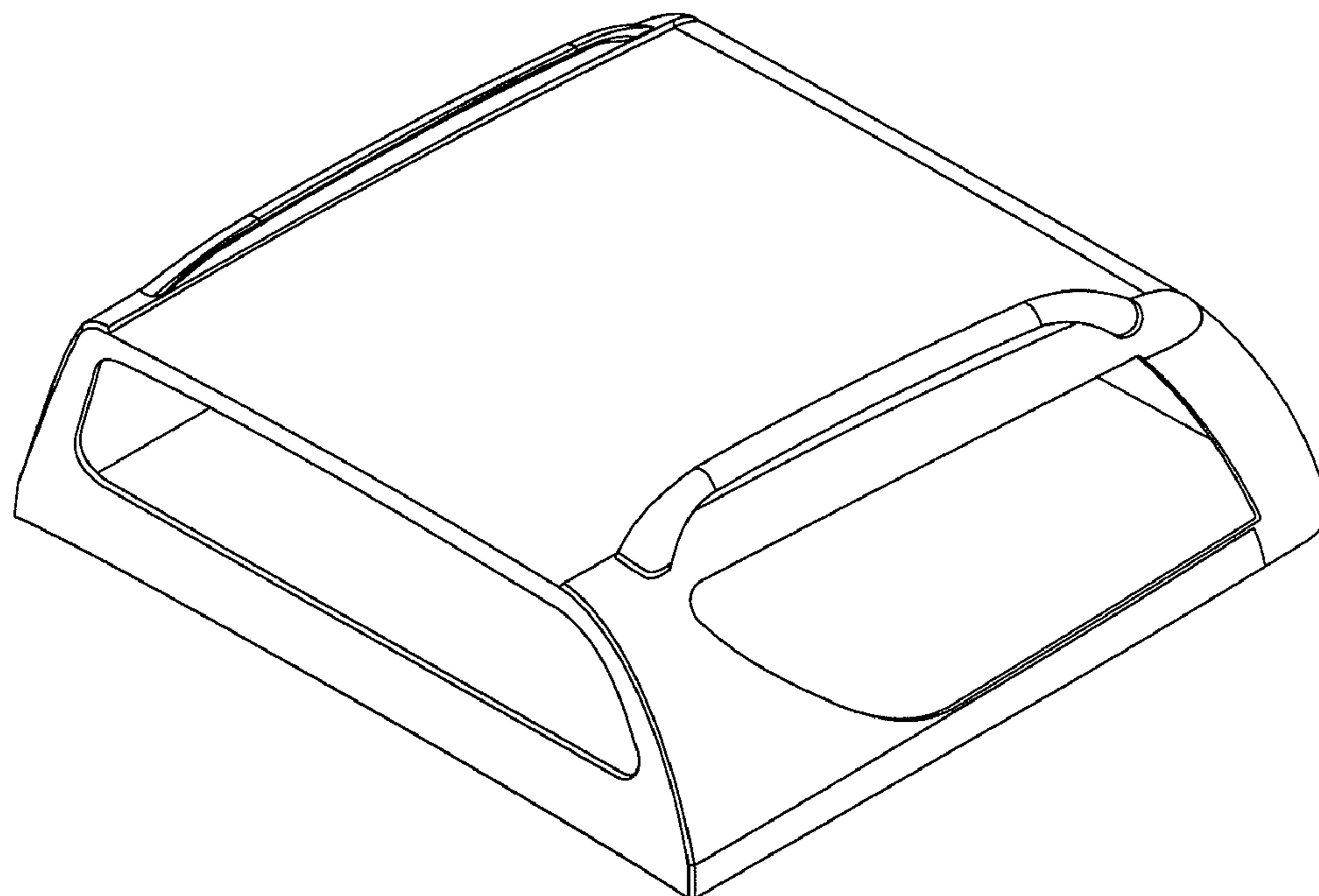

**FIG. 5**

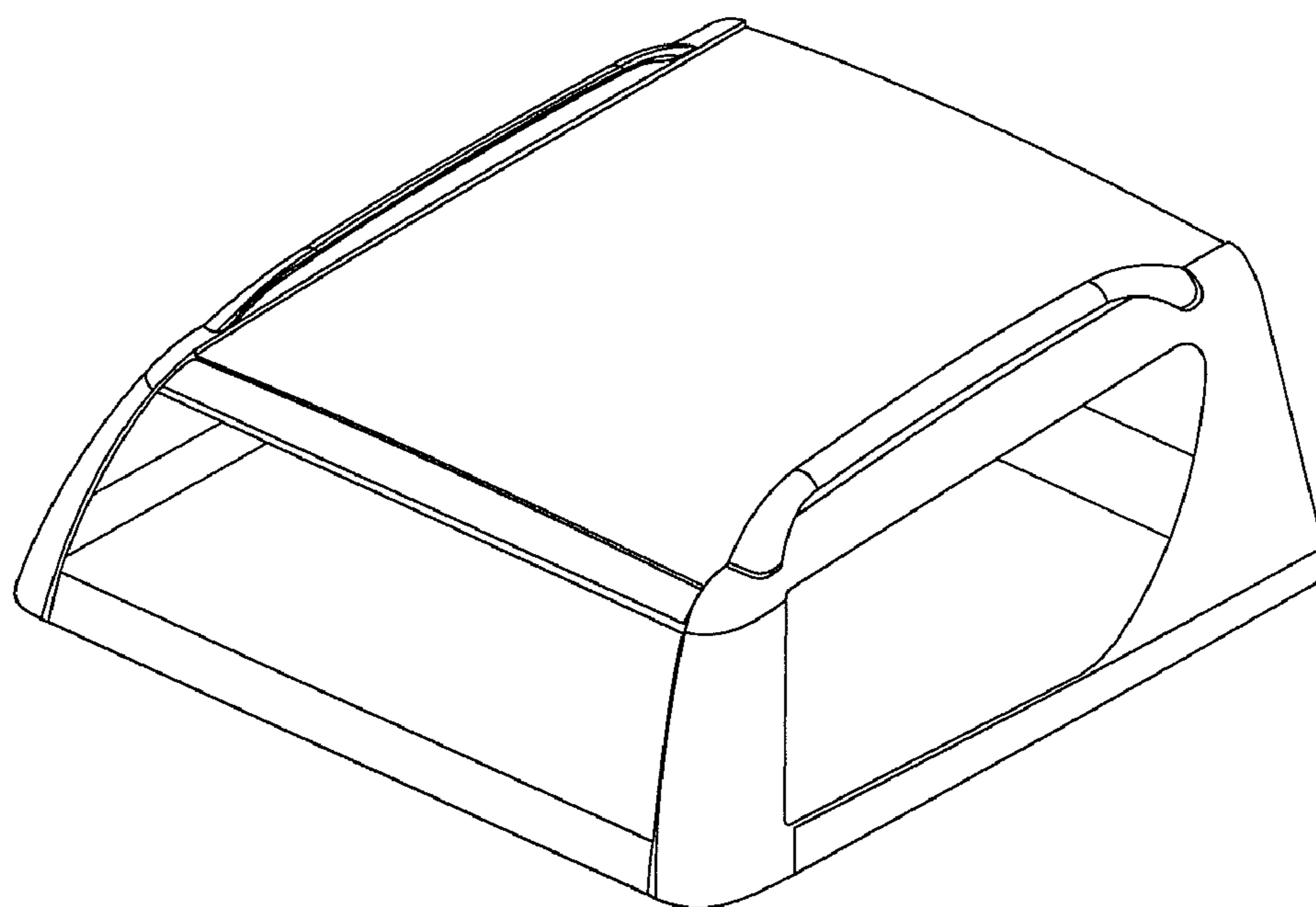

**FIG. 6**