



US00D623481S

(12) **United States Design Patent**  
**Moran**

(10) **Patent No.:** **US D623,481 S**  
(45) **Date of Patent:** **\*\* \*Sep. 14, 2010**

(54) **THERMAL CONTAINER**

(75) Inventor: **Jorge Eugene Moran**, Nashville, TN (US)

(73) Assignee: **Megatrade International, Inc.**, Nashville, TN (US)

(\*\*) Term: **14 Years**

(21) Appl. No.: **29/353,099**

(22) Filed: **Dec. 31, 2009**

(51) **LOC (9) Cl.** ..... **07-01**

(52) **U.S. Cl.** ..... **D7/608**

(58) **Field of Classification Search** ..... D7/608,  
D7/510, 511; 215/12.1, 12.2, 13.1, 6; D9/549-559;  
220/592.2, 915.1, 915.2

See application file for complete search history.

(56) **References Cited**

U.S. PATENT DOCUMENTS

D395,203 S 6/1998 Moran  
D395,793 S 7/1998 Moran

(Continued)

FOREIGN PATENT DOCUMENTS

FR 2866324 8/2005

*Primary Examiner*—Terry A Wallace

(74) *Attorney, Agent, or Firm*—Hunton & Williams LLP

(57) **CLAIM**

We claim the ornamental design for a thermal container, as shown and described.

**DESCRIPTION**

FIG. 1 depicts a perspective view of a thermal container.  
FIG. 2 depicts a front elevation view of a thermal container.  
FIG. 3 depicts a rear elevation view of a thermal container.  
FIG. 4 depicts a side elevation view of a thermal container.  
FIG. 5 depicts an opposite side elevation view of a thermal container.

FIG. 6 depicts a top plan view of a thermal container.  
FIG. 7 depicts a bottom plan view of a thermal container.  
FIG. 8 depicts a perspective view of a thermal container.  
FIG. 9 depicts a front elevation view of a thermal container.  
FIG. 10 depicts a rear elevation view of a thermal container.  
FIG. 11 depicts a side elevation view of a thermal container.  
FIG. 12 depicts an opposite side elevation view of a thermal container.  
FIG. 13 depicts a top plan view of a thermal container.  
FIG. 14 depicts a bottom plan view of a thermal container.  
FIG. 15 depicts a perspective view of a thermal container.  
FIG. 16 depicts a front elevation view of a thermal container.  
FIG. 17 depicts a rear elevation view of a thermal container.  
FIG. 18 depicts a side elevation view of a thermal container.  
FIG. 19 depicts an opposite side elevation view of a thermal container.  
FIG. 20 depicts a top plan view of a thermal container.  
FIG. 21 depicts a bottom plan view of a thermal container.  
FIG. 22 depicts a perspective view of a thermal container.  
FIG. 23 depicts a front elevation view of a thermal container.  
FIG. 24 depicts a rear elevation view of a thermal container.  
FIG. 25 depicts a side elevation view of a thermal container.  
FIG. 26 depicts an opposite side elevation view of a thermal container.  
FIG. 27 depicts a top plan view of a thermal container.  
FIG. 28 depicts a bottom plan view of a thermal container; and,  
FIG. 29 depicts an exploded perspective view of a thermal container.

The broken lines in the drawings illustrate environmental structure on the article and form no part of the claimed design. The cup, closure and container are shown separately in the drawings for clarity of illustration.

**1 Claim, 25 Drawing Sheets**

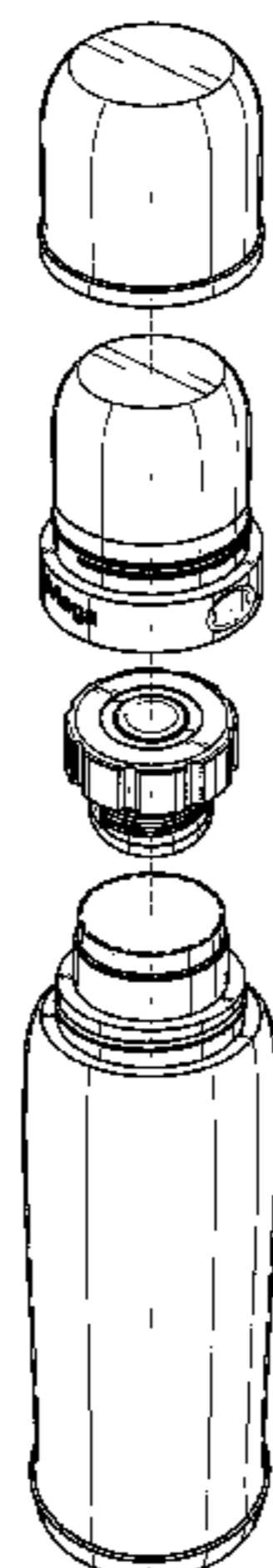

# US D623,481 S

Page 2

---

## U.S. PATENT DOCUMENTS

D395,794 S	7/1998	Moran	D488,961 S	4/2004	Moran	
D406,014 S	2/1999	Moran	D490,275 S	5/2004	Moran	
D407,273 S	3/1999	Moran	6,764,622 B2	7/2004	Moran	
D410,175 S	5/1999	Moran	D497,778 S *	11/2004	Rich .....	D7/608
D411,717 S	6/1999	Moran	D500,231 S *	12/2004	Ward et al. ....	D7/608
D415,936 S	11/1999	Moran	D513,688 S	1/2006	Moran	
6,332,557 B1	12/2001	Moran	D518,380 S	4/2006	Moran	
D452,799 S	1/2002	Moran	D533,032 S *	12/2006	Liu et al. ....	D7/608
6,530,496 B2	3/2003	Moran	D553,914 S *	10/2007	Wahl .....	D7/608
6,536,620 B2	3/2003	Moran	D572,981 S *	7/2008	Carreno .....	D7/608

\* cited by examiner

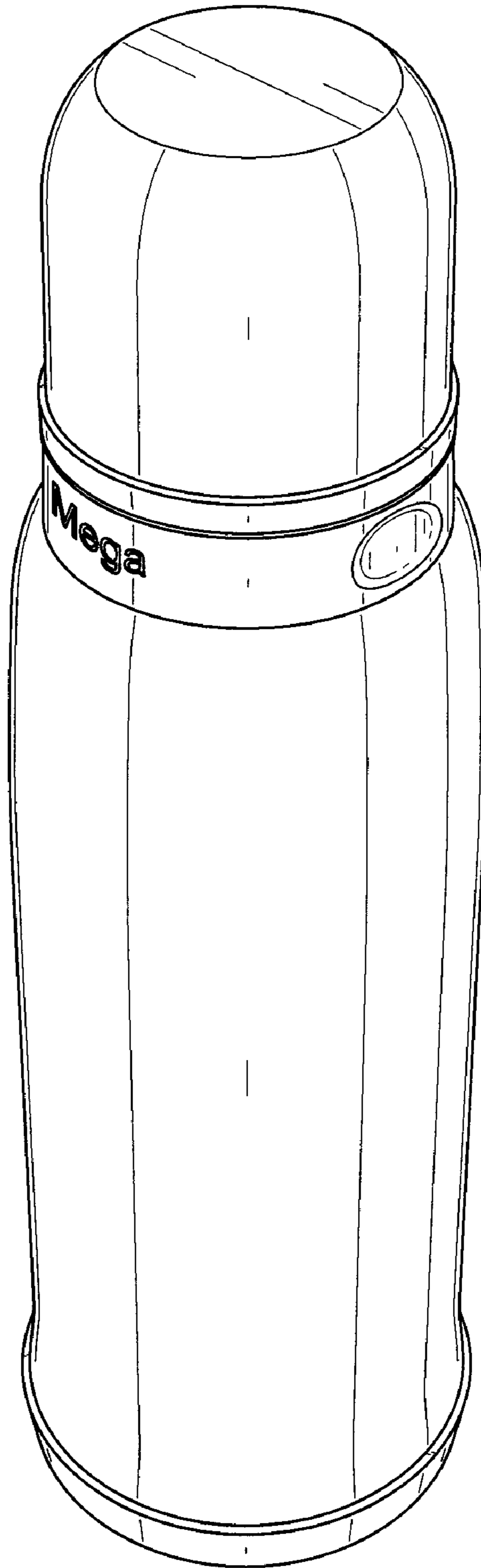

FIG. 1

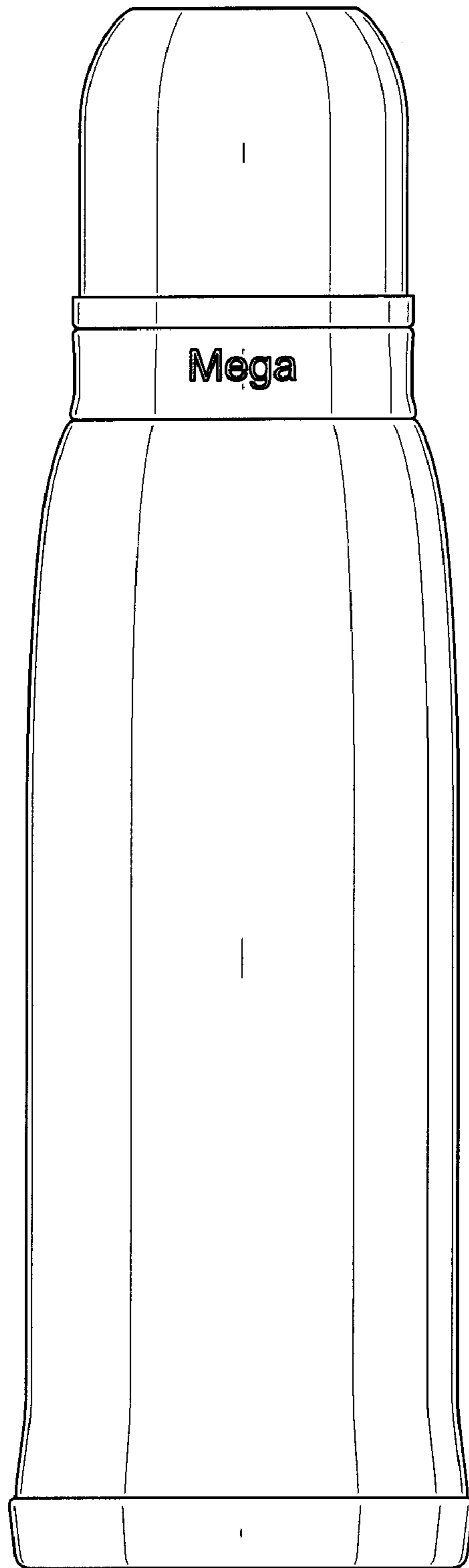

FIG. 2

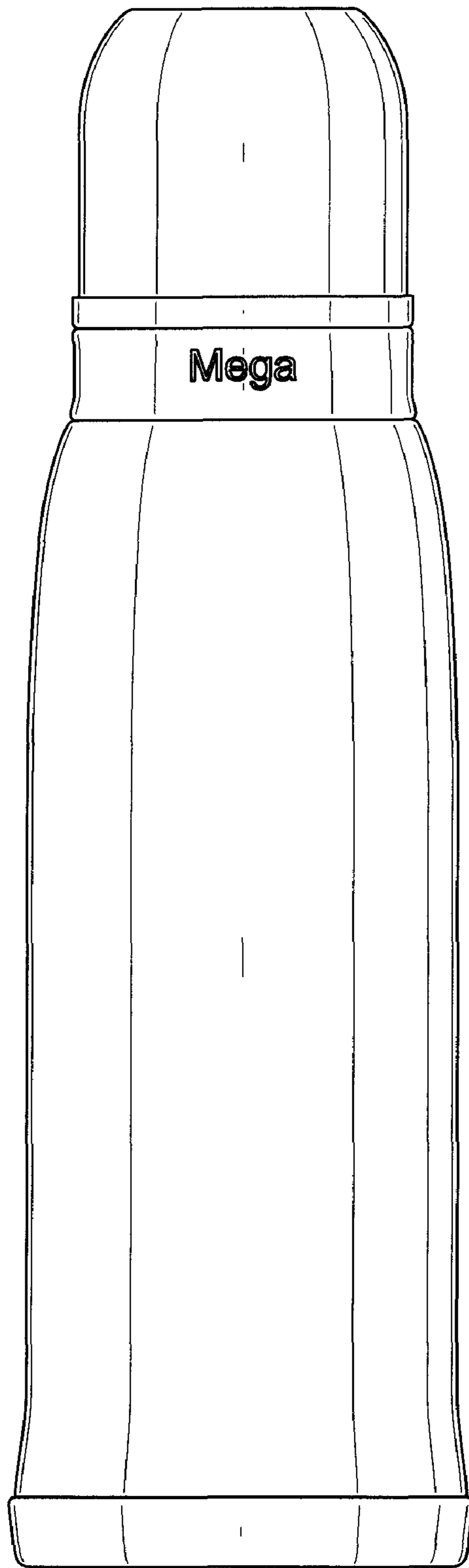

FIG. 3

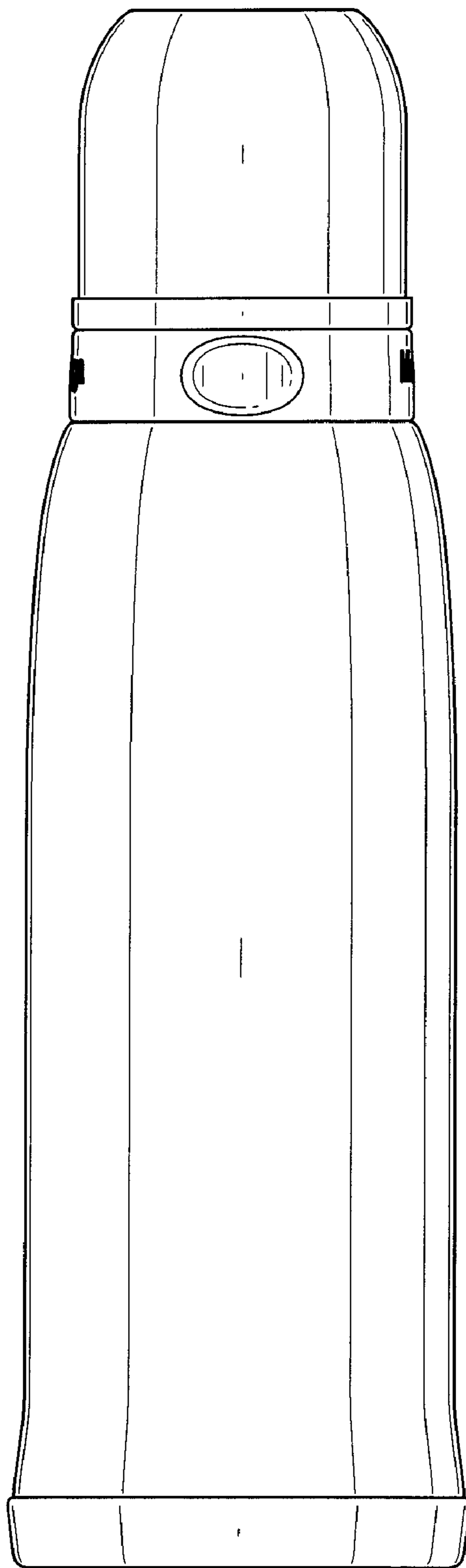

FIG. 4

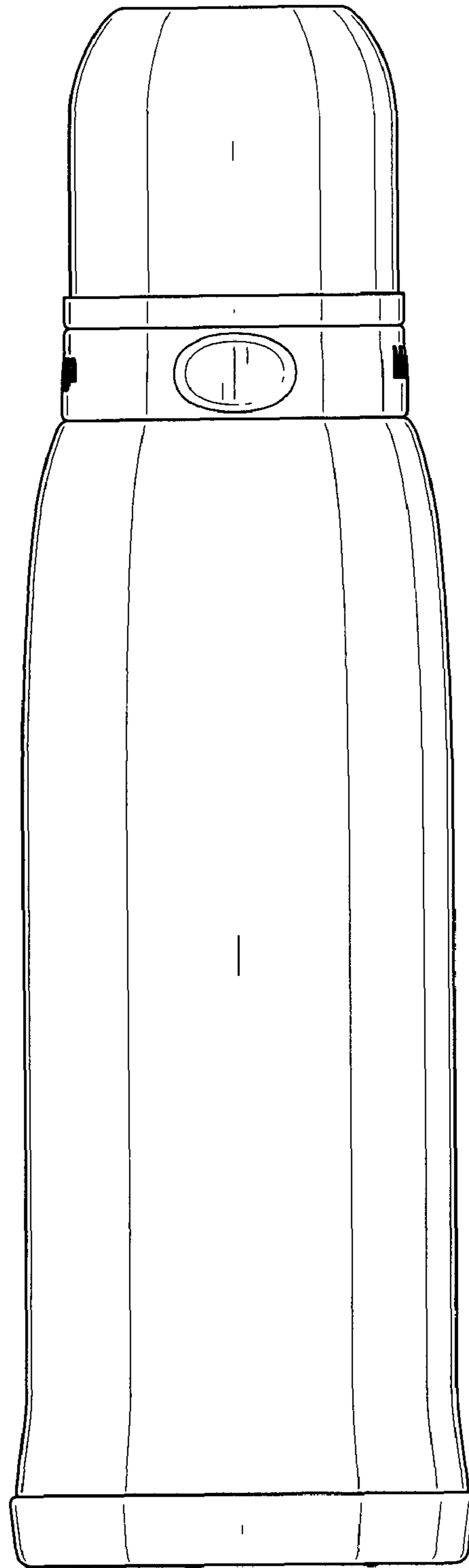

FIG. 5

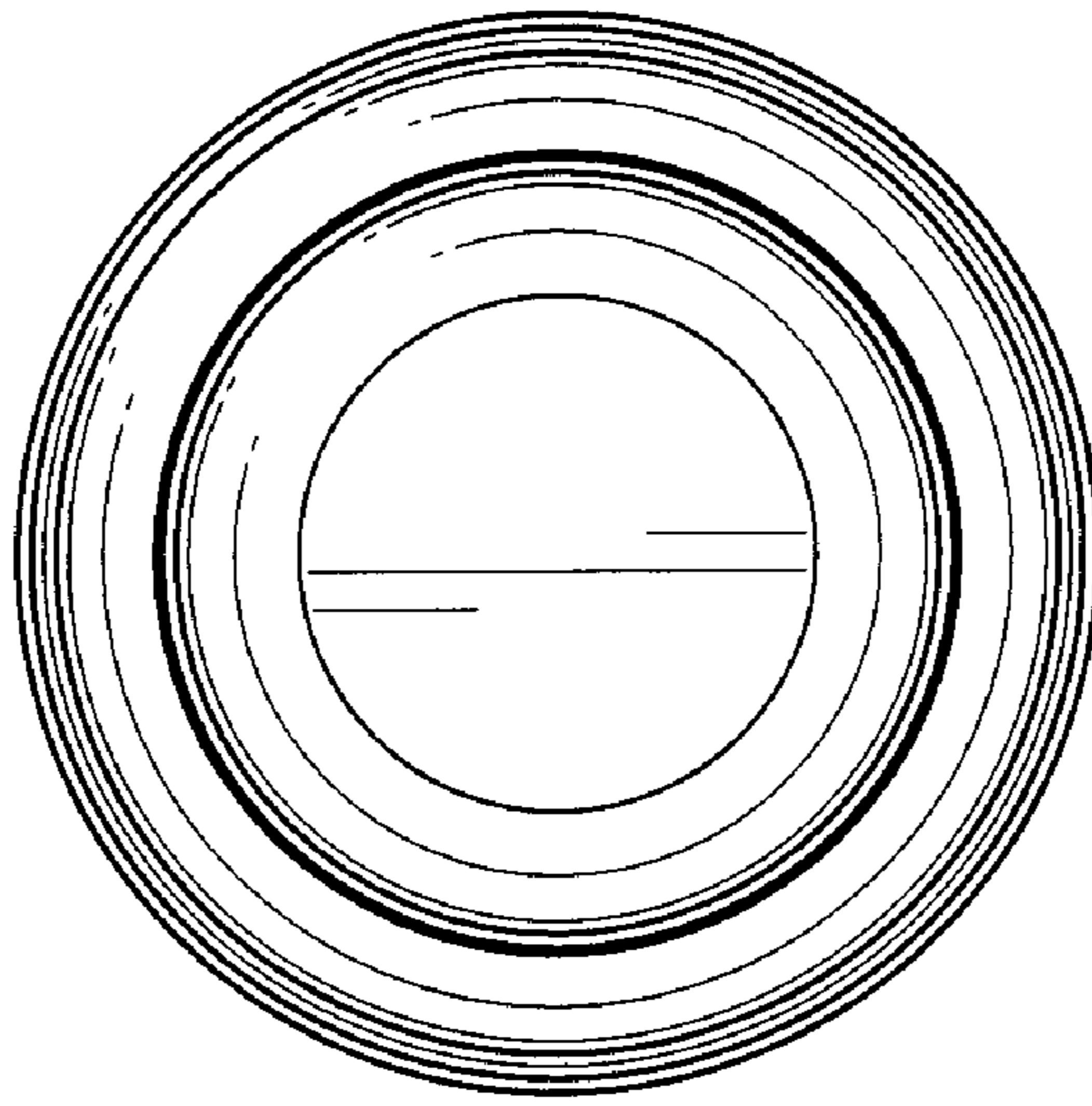

FIG. 6

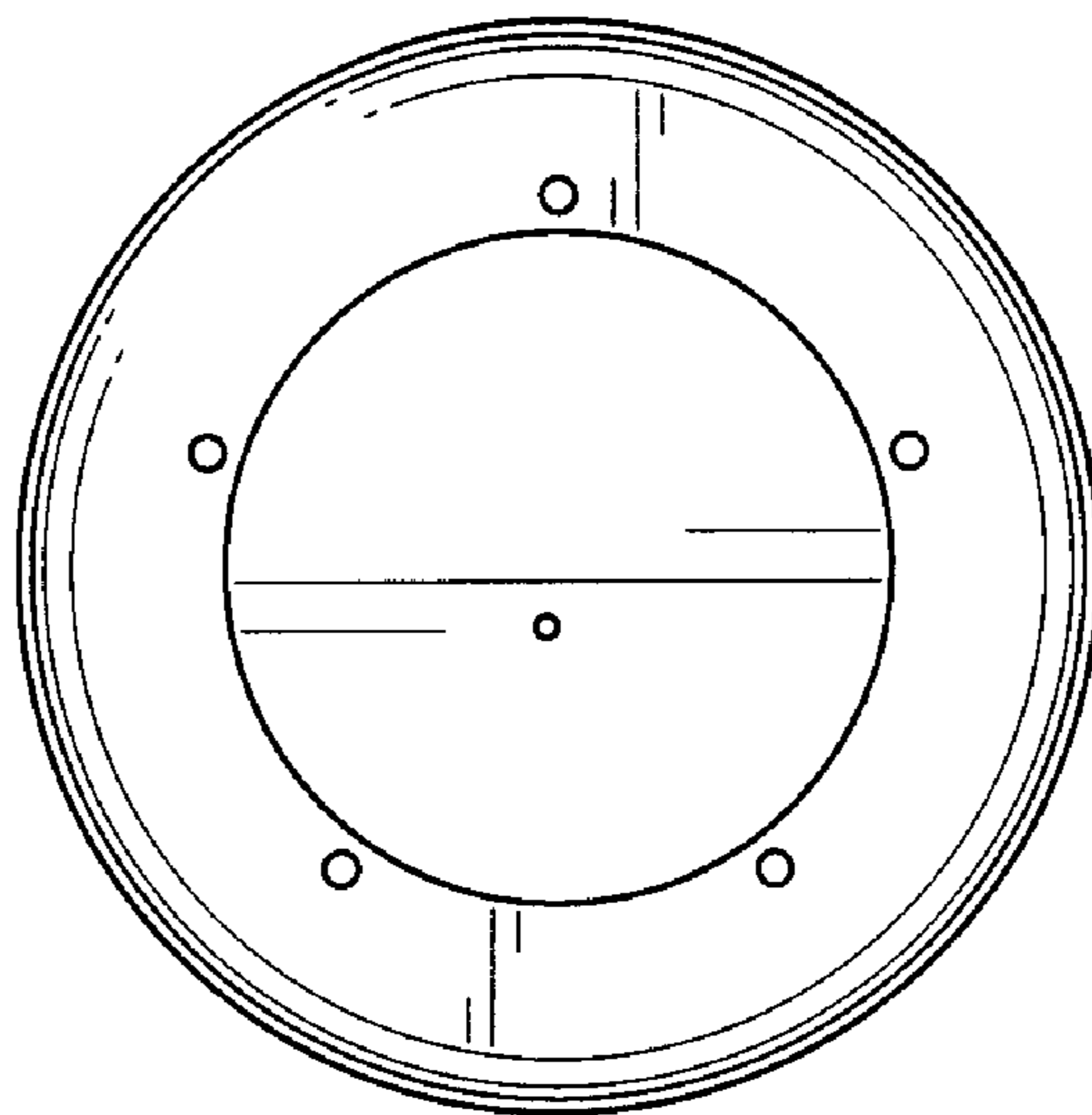

FIG. 7



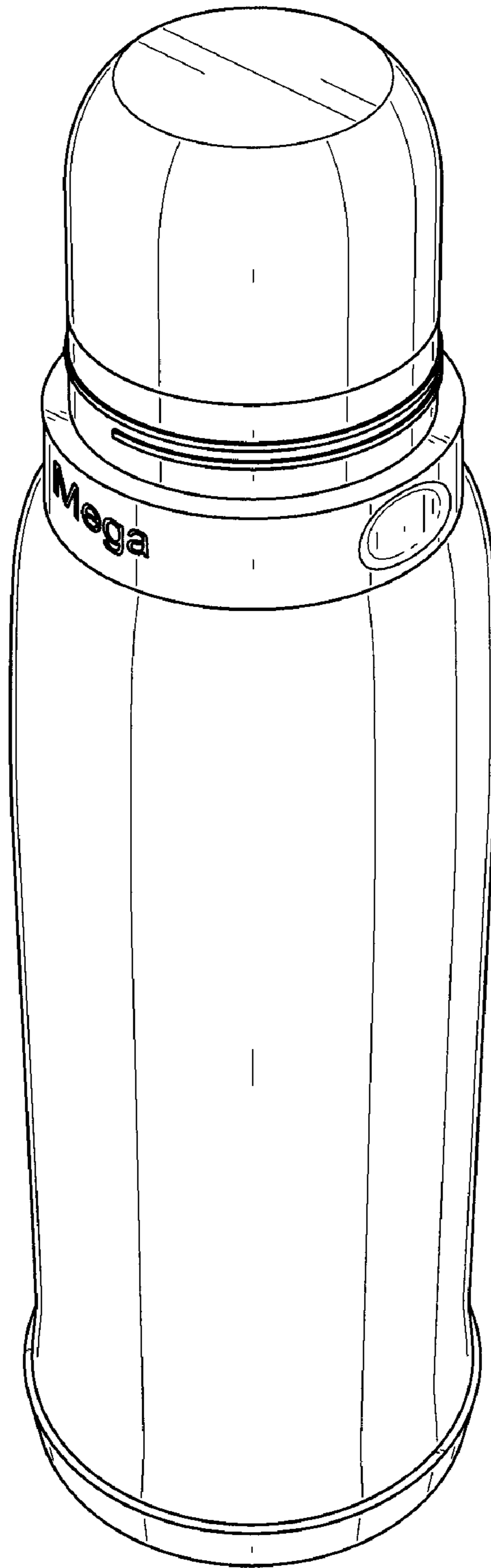

FIG. 8

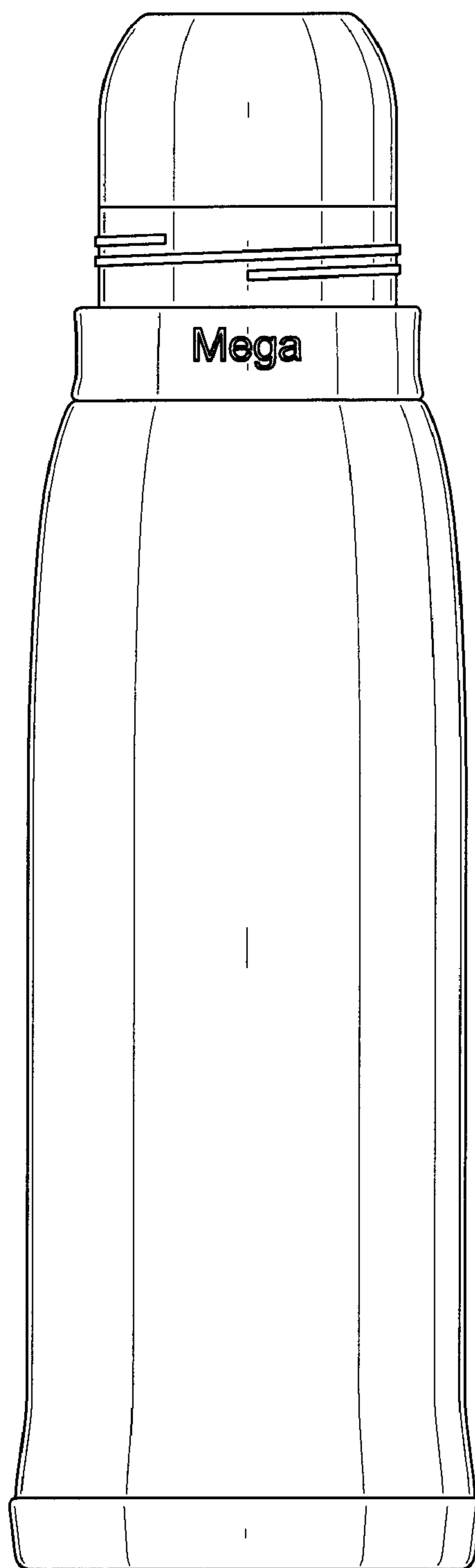

FIG. 9

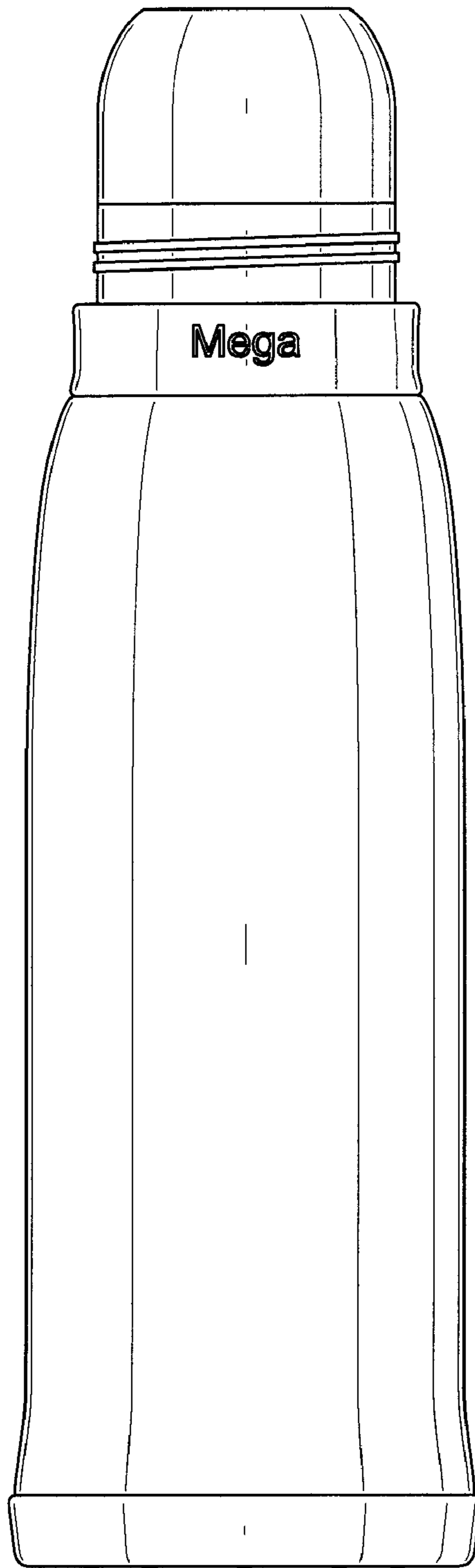

FIG. 10

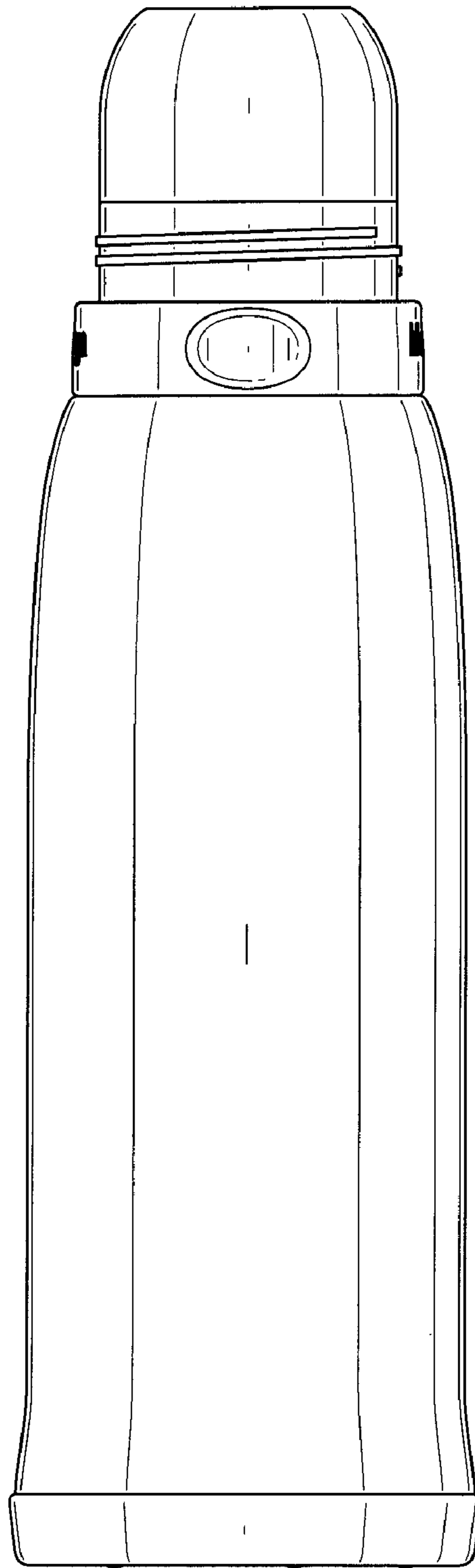

FIG. 11

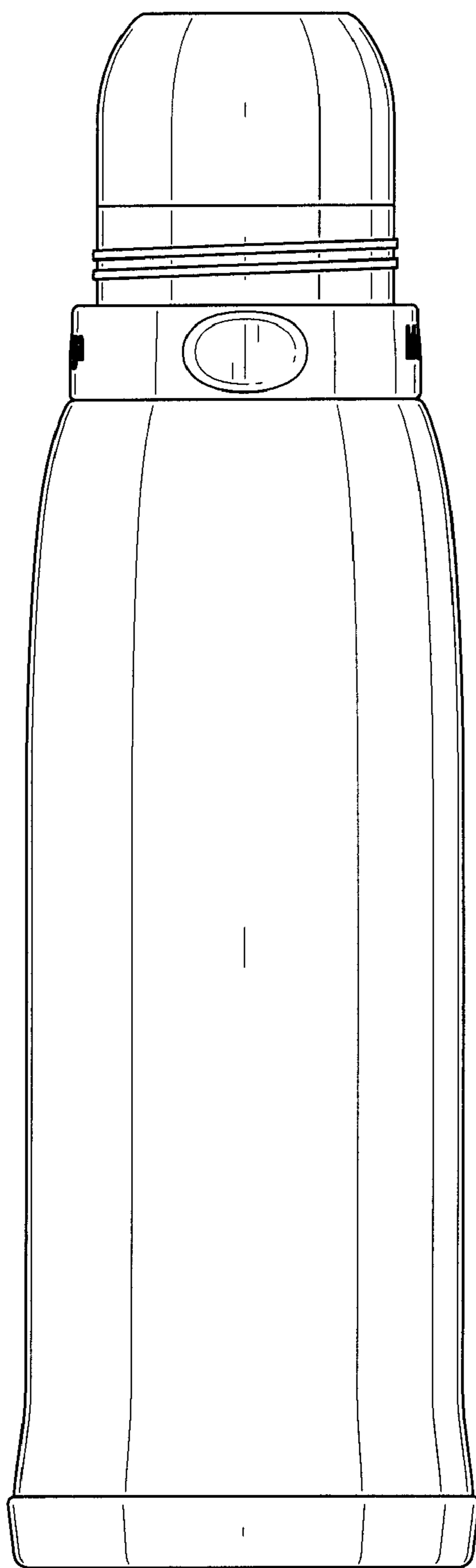

FIG. 12

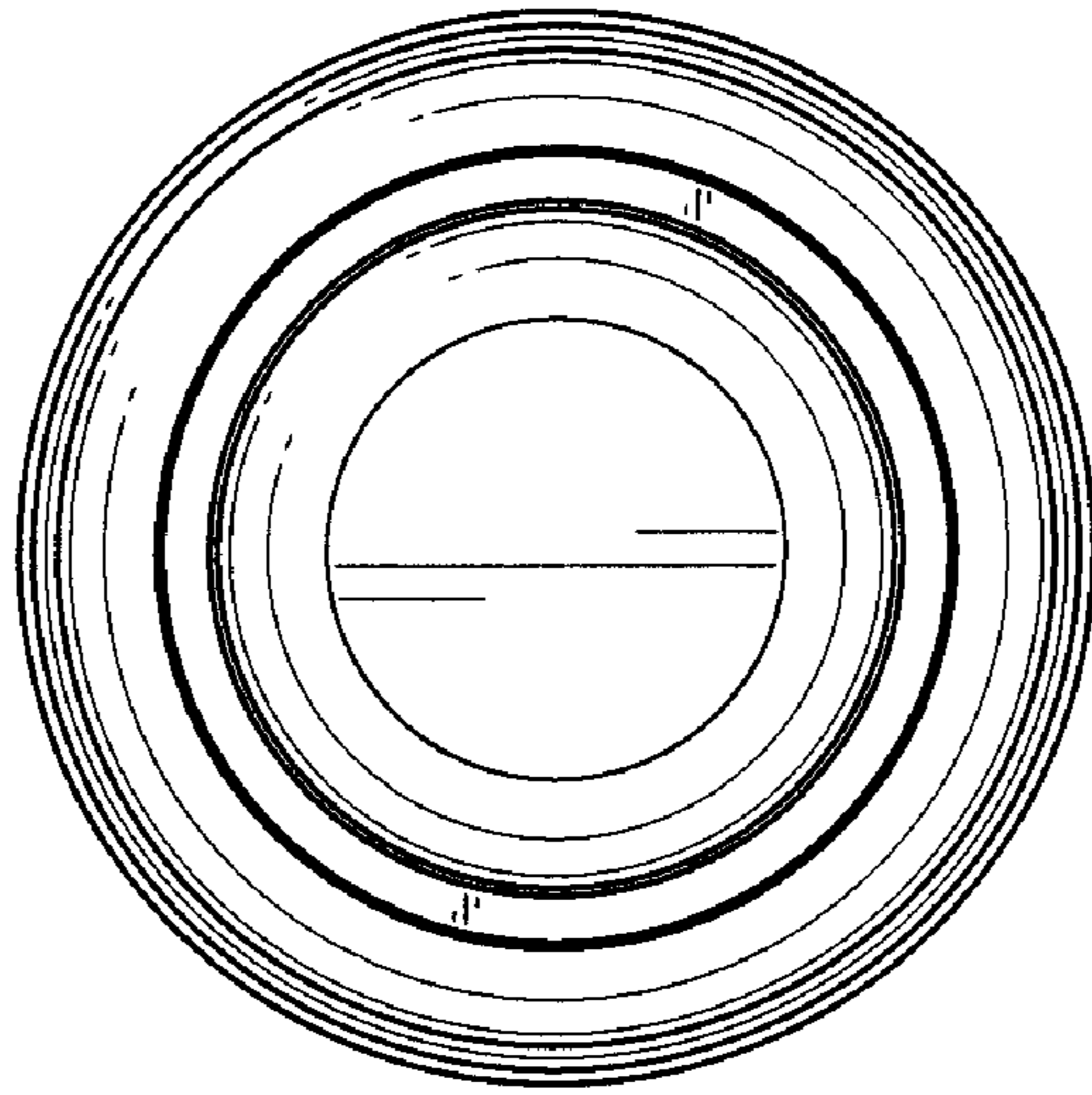

FIG. 13

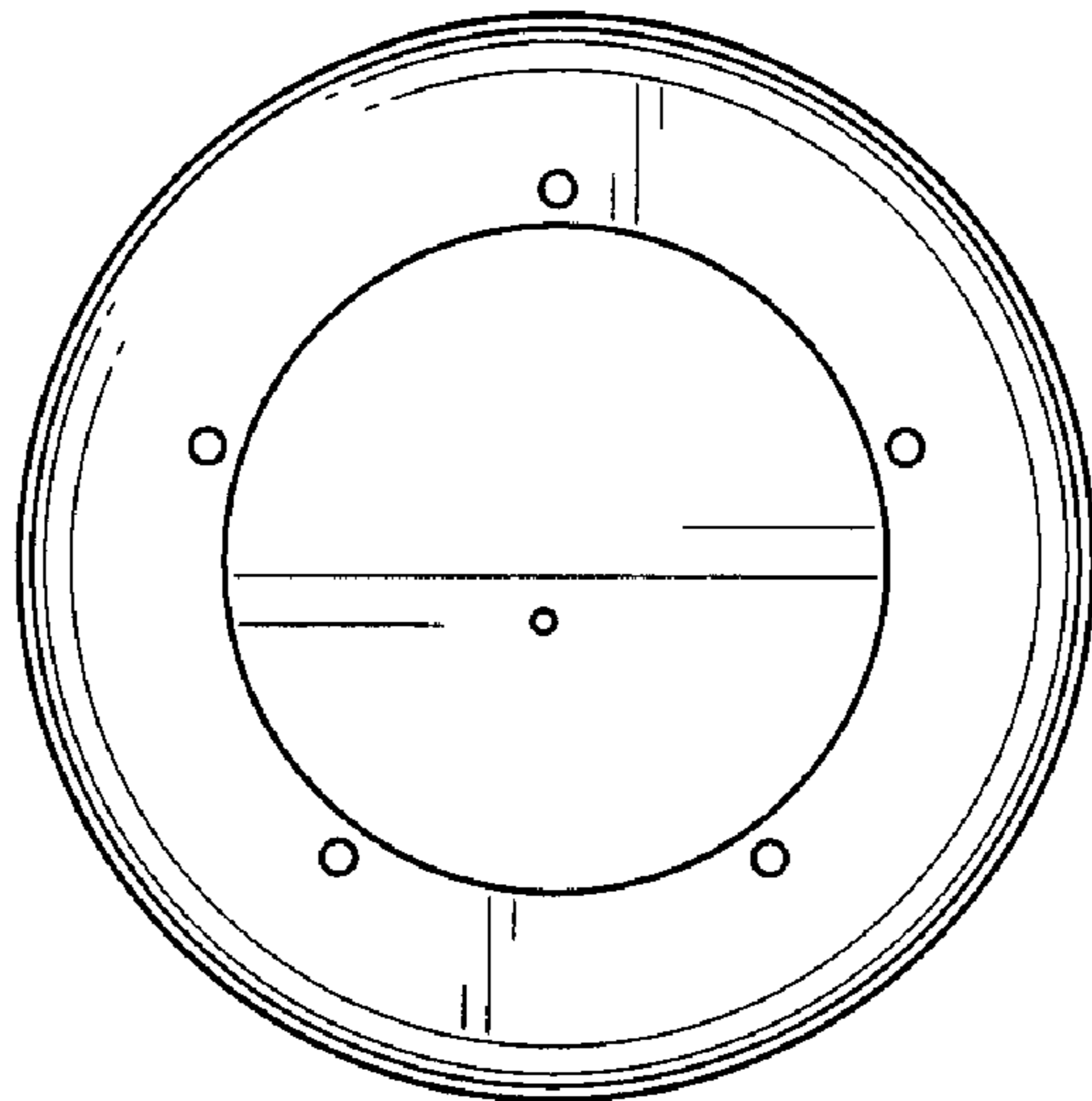

FIG. 14

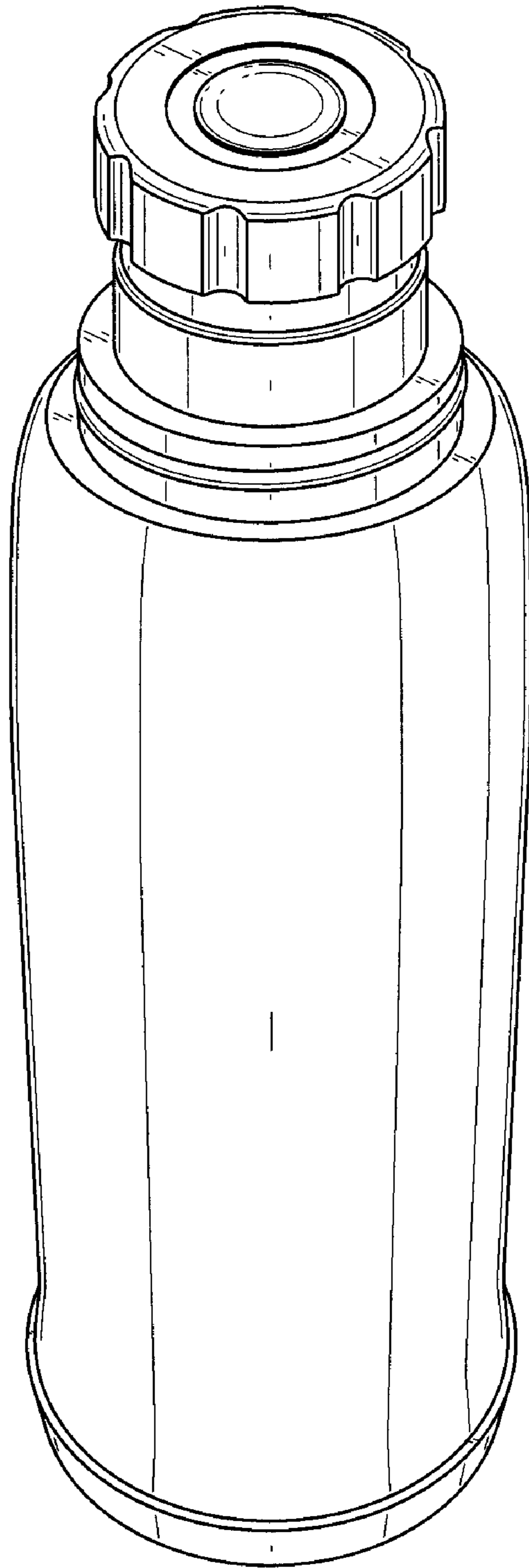

FIG. 15

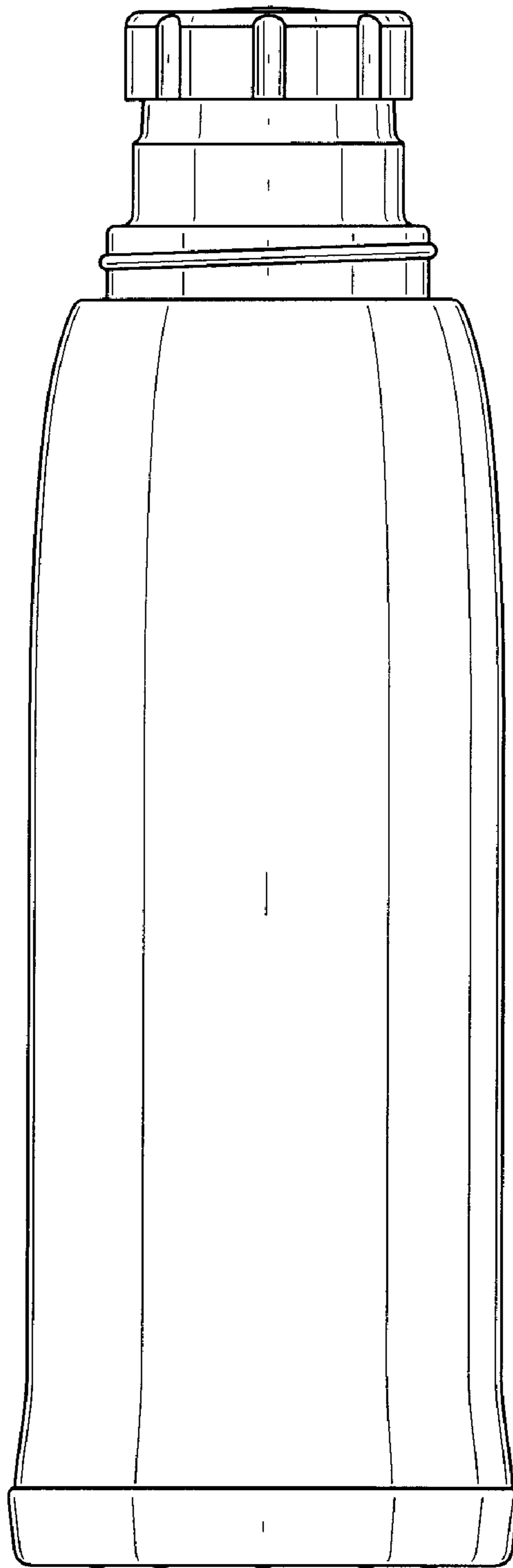

FIG. 16



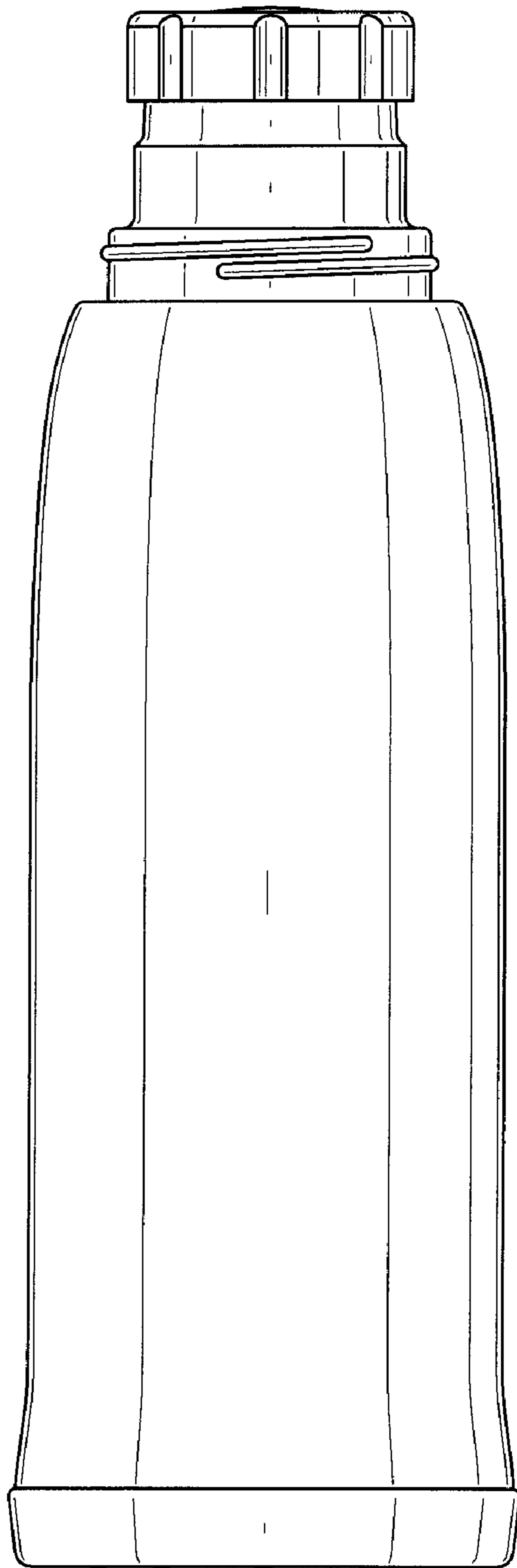

FIG. 17

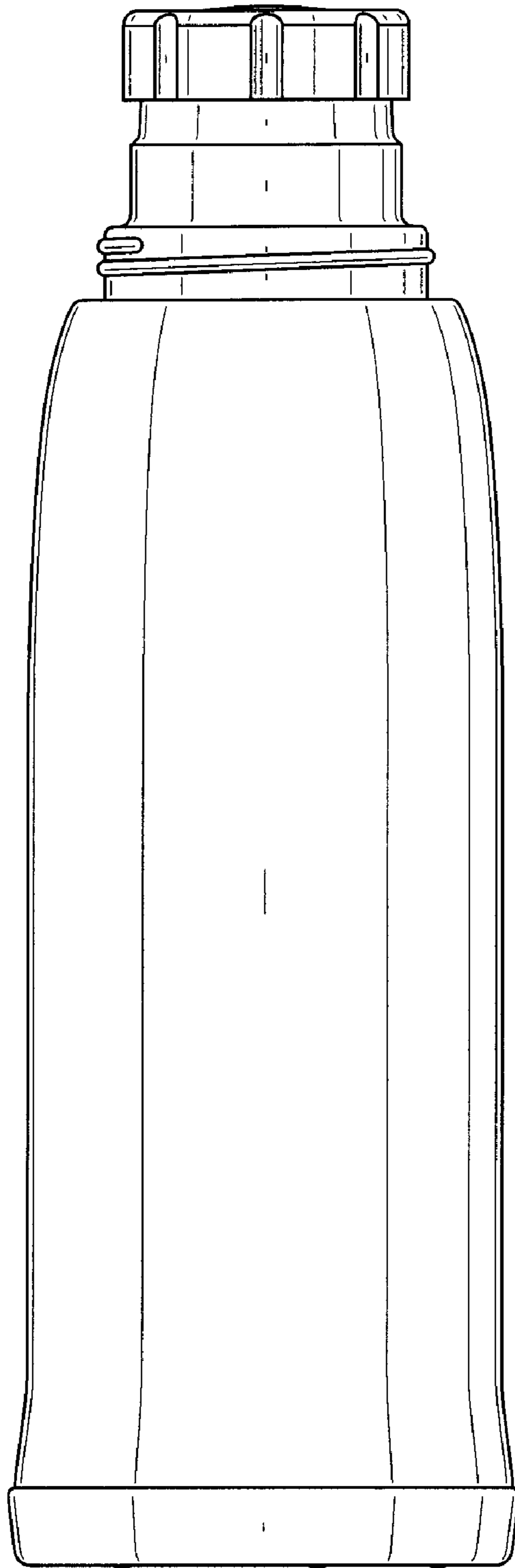

FIG. 18

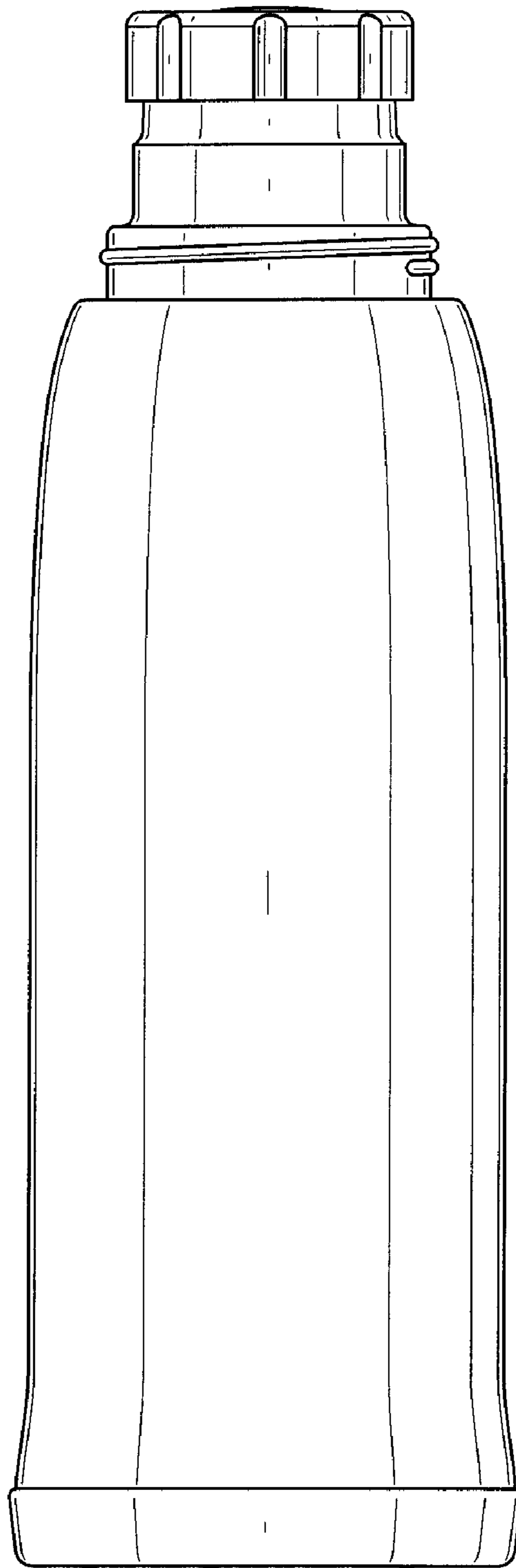

FIG. 19

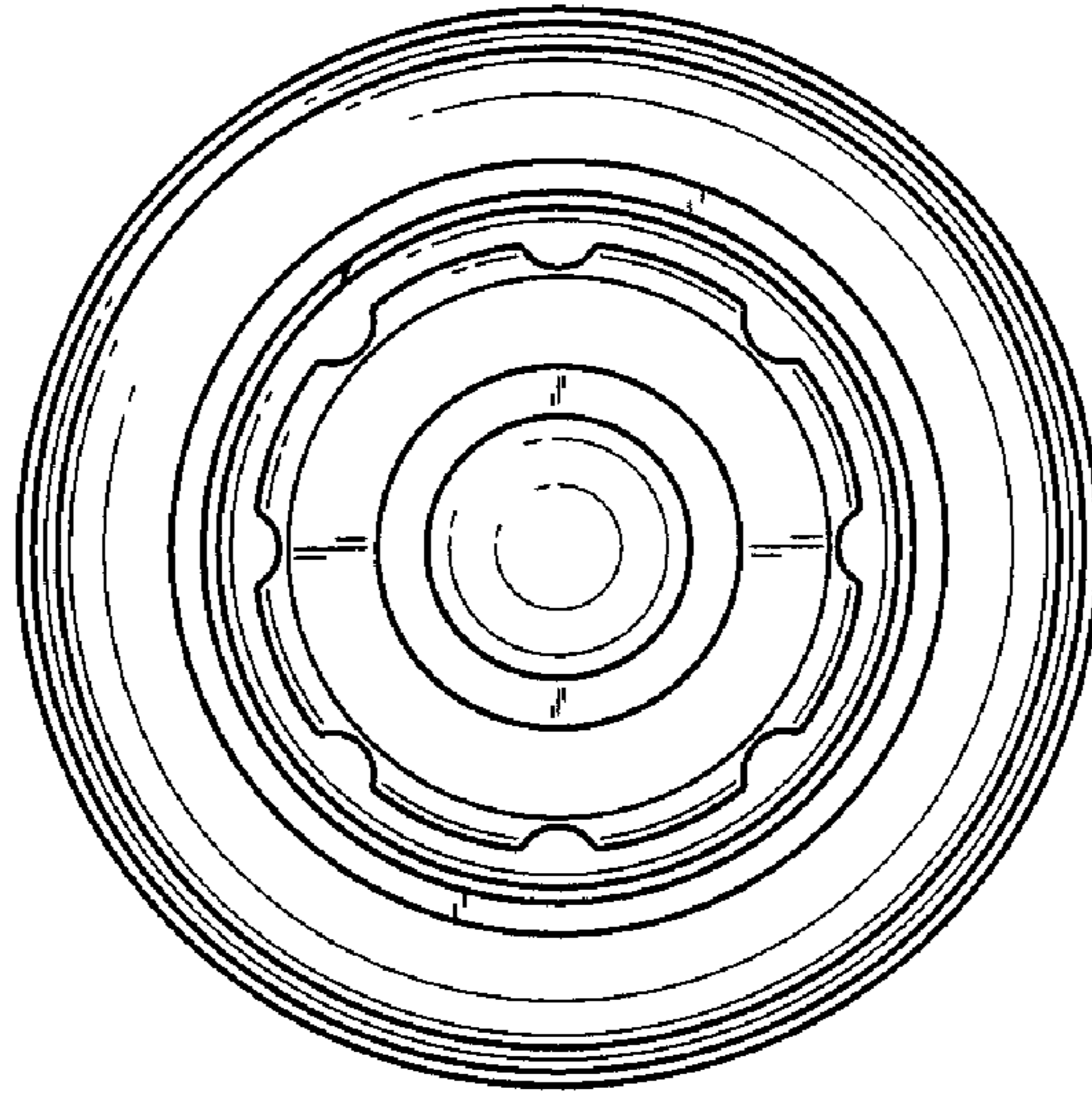

FIG. 20

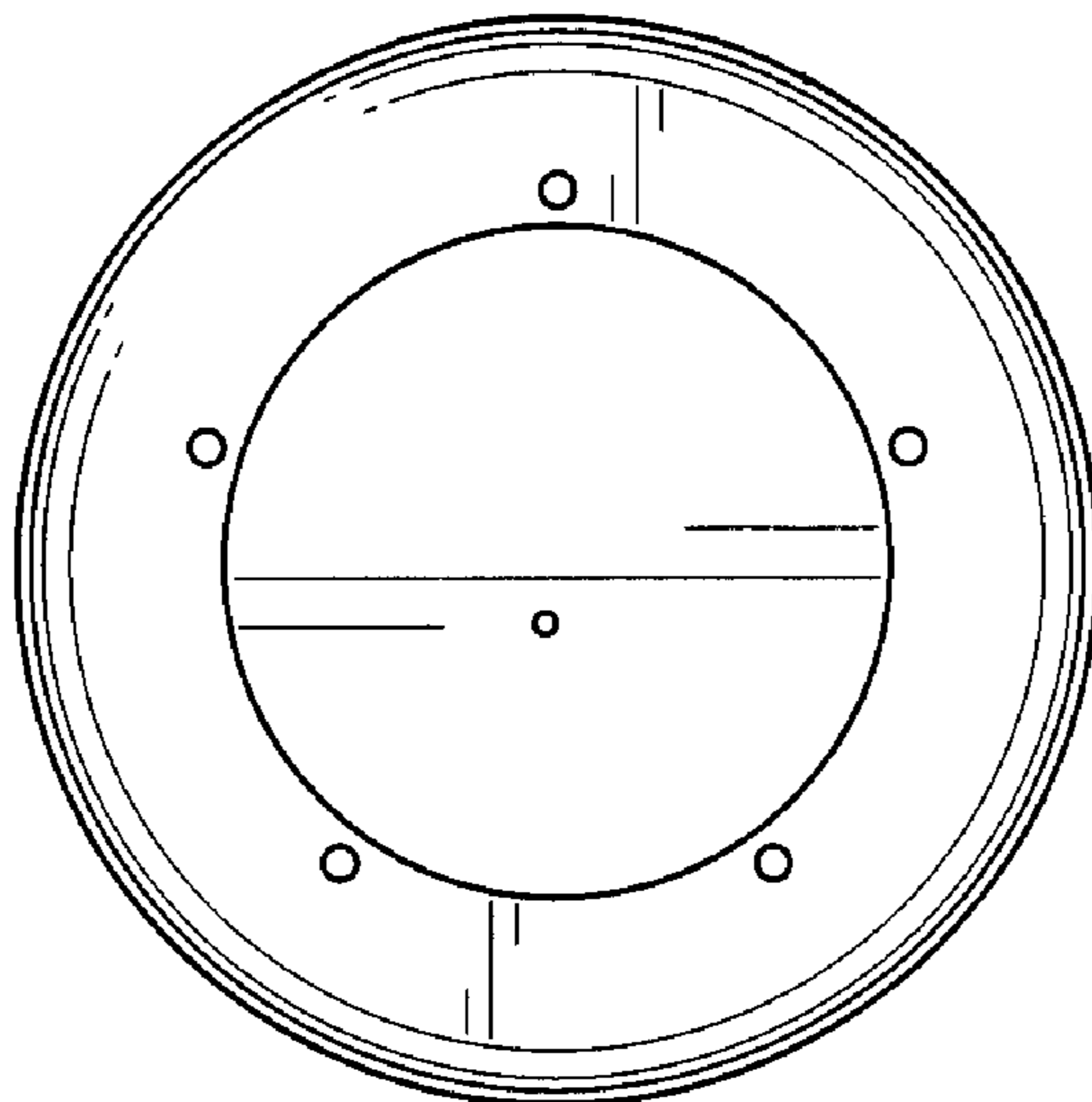

FIG. 21

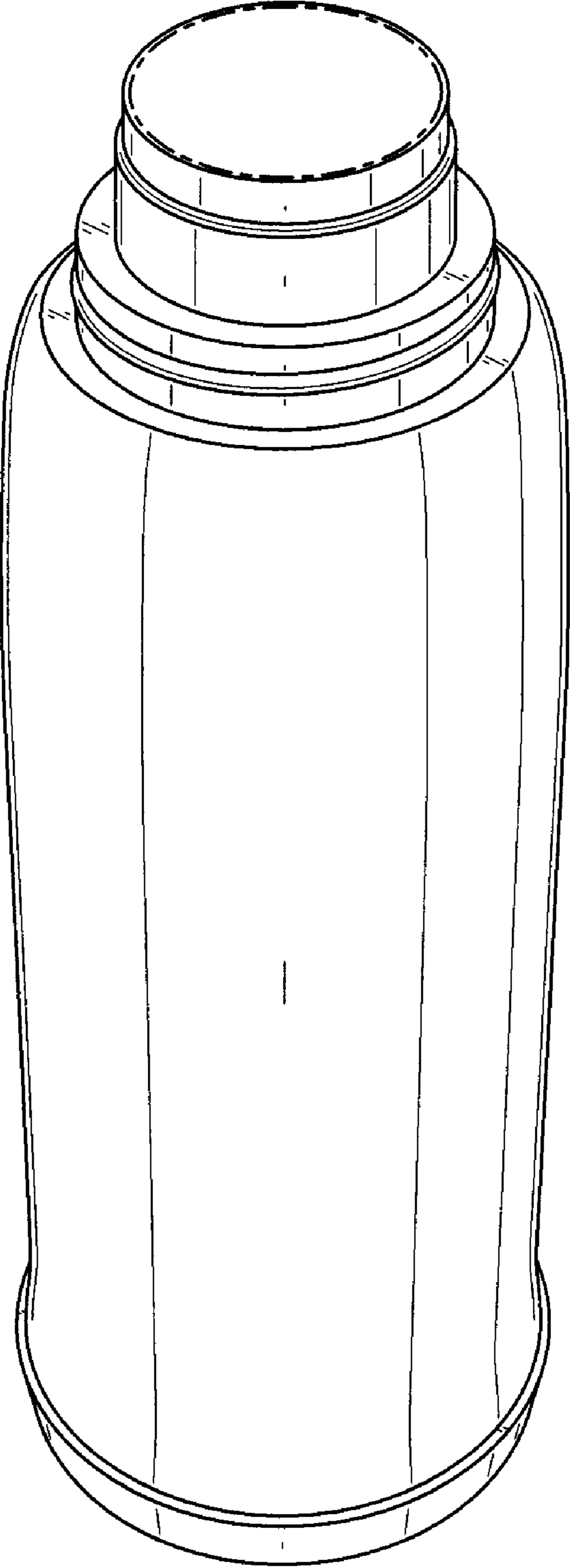

FIG. 22

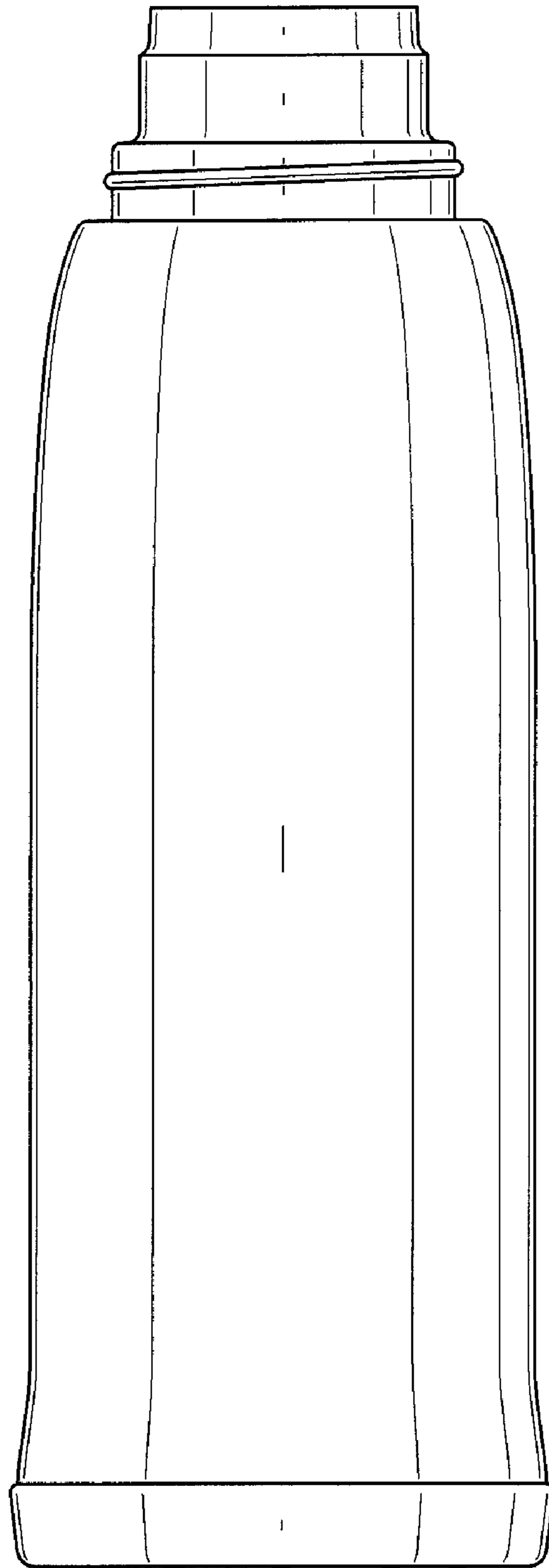

FIG. 23

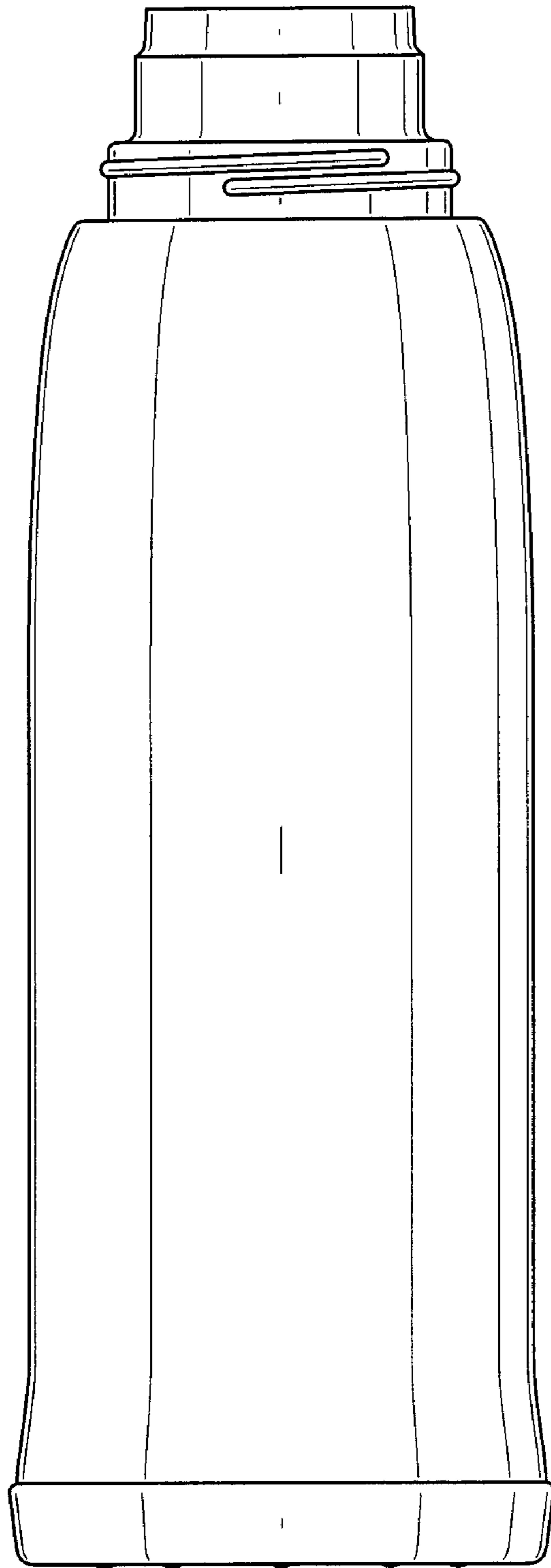

FIG. 24

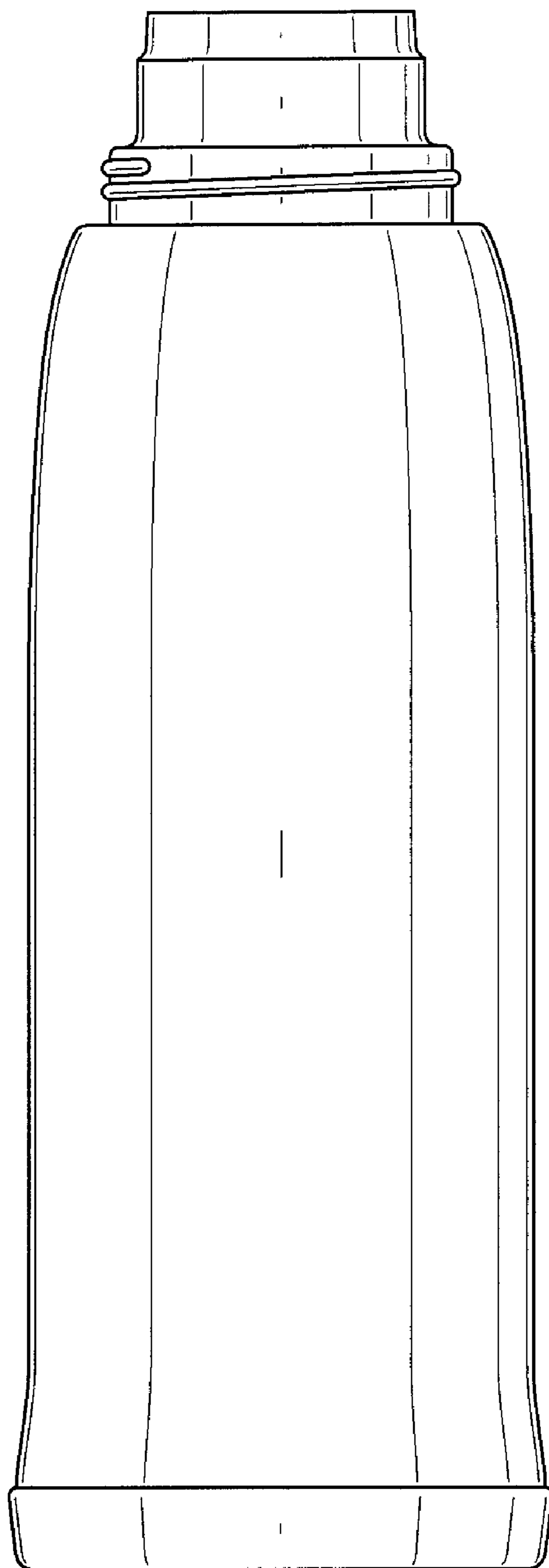

FIG. 25



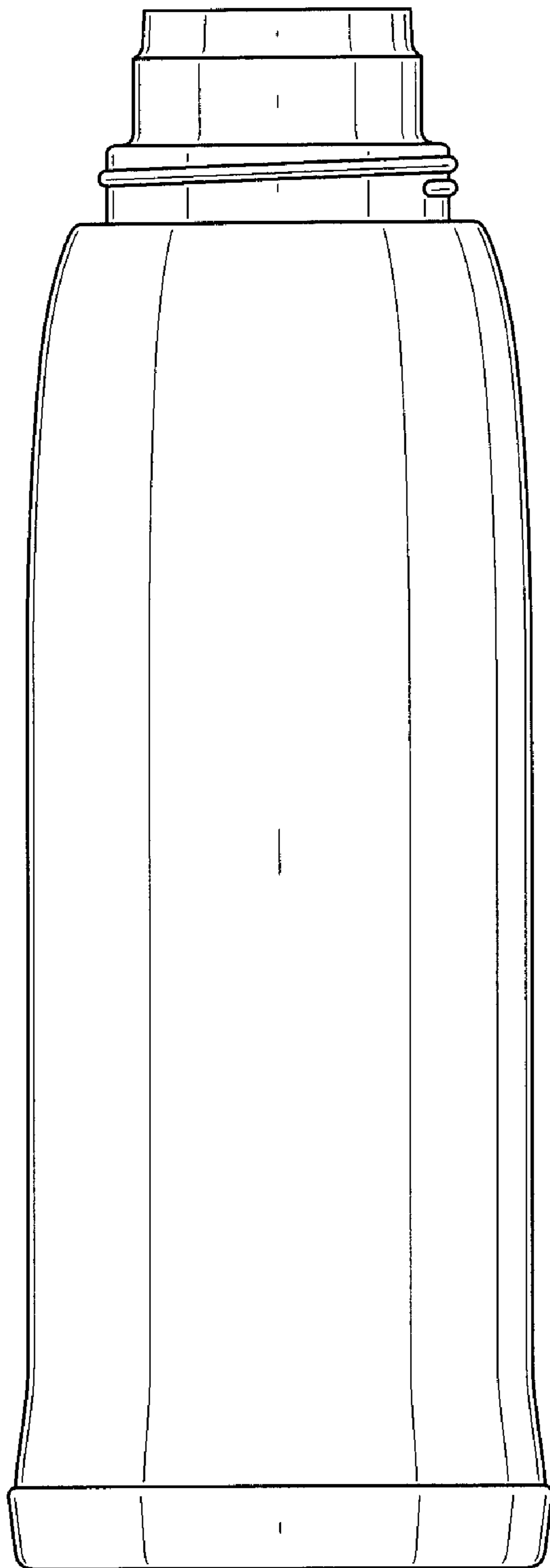

FIG. 26

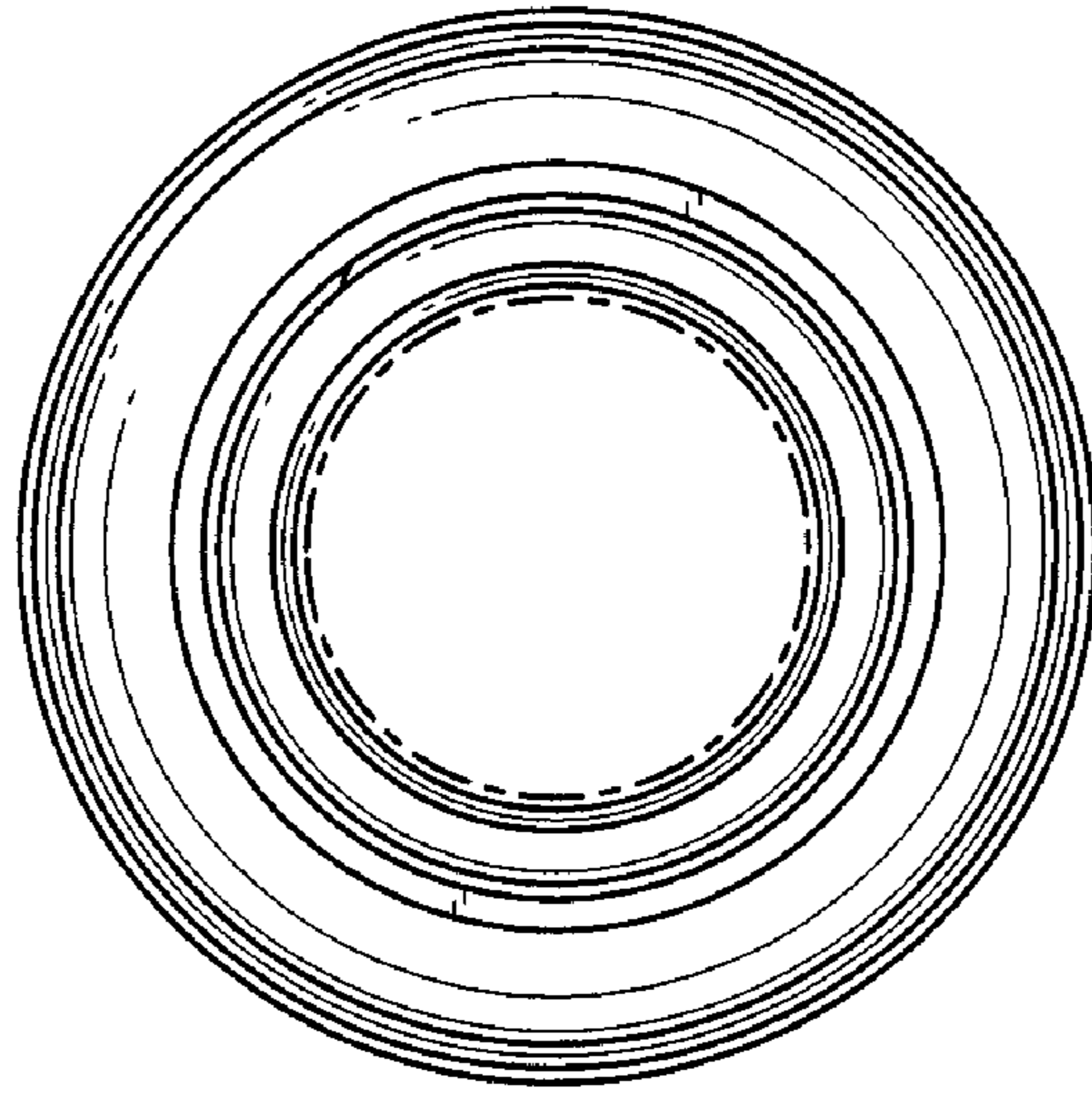

FIG. 27

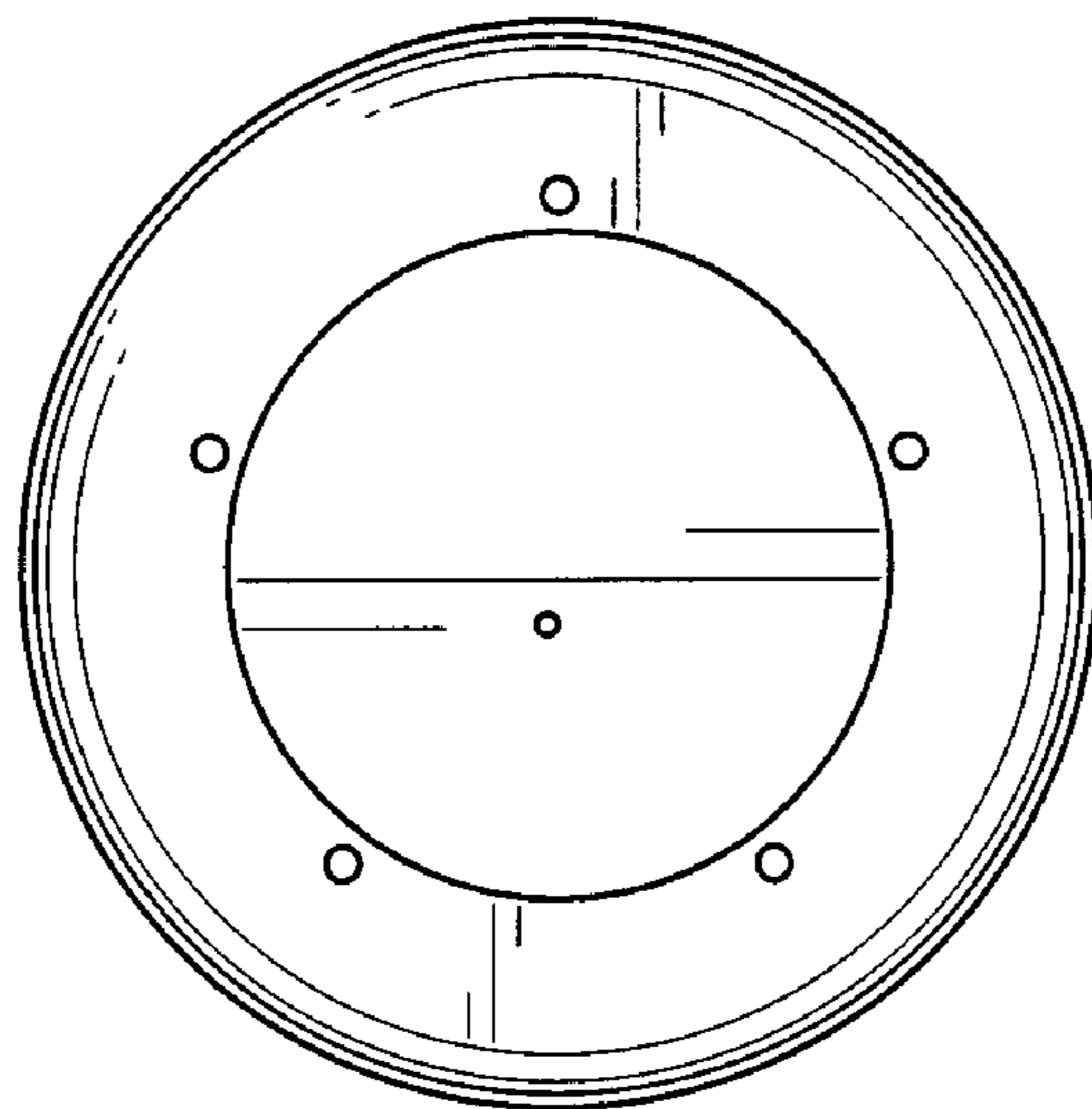

FIG. 28

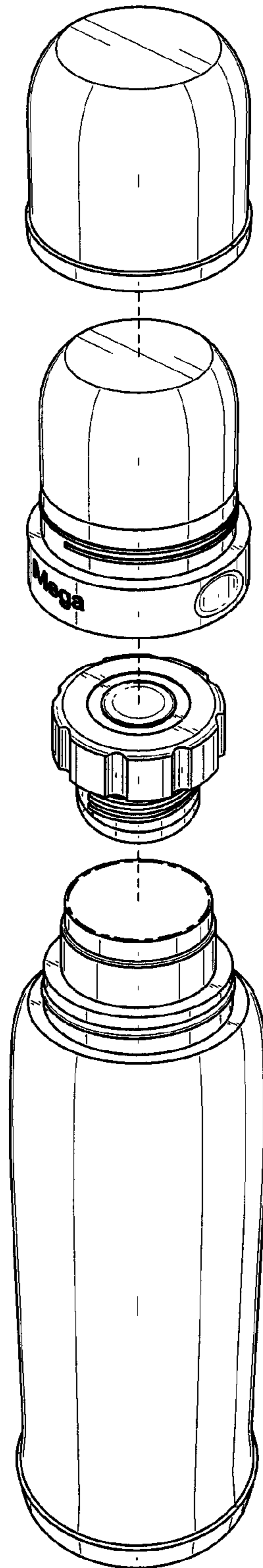

FIG. 29