



US00D623397S

(12) **United States Design Patent**
Cooper

(10) **Patent No.:** **US D623,397 S**

(45) **Date of Patent:** **** Sep. 14, 2010**

(54) **RACE CAR FLASK**

Primary Examiner—Catherine R Oliver

(76) Inventor: **Gary Cooper**, 1616 S. Vossi Suite 530,
Houston, TX (US) 77057

(57) **CLAIM**

The ornamental design for a race car flask, as shown.

(**) Term: **14 Years**

DESCRIPTION

(21) Appl. No.: **29/316,658**

FIG. 1 is a front and left side perspective view of the race car flask showing my new design;

(22) Filed: **Nov. 12, 2009**

FIG. 2 is a rear and left side perspective view thereof;

(51) **LOC (9) Cl.** **09-02**

FIG. 3 is a bottom plan view thereof;

(52) **U.S. Cl.** **D3/202**

FIG. 4 is a top plan view thereof;

(58) **Field of Classification Search** D3/202,
D3/201, 229; 224/148.1–148.7; 220/23.86,
220/23.83; 206/547

FIG. 5 is a left side elevation view thereof;

See application file for complete search history.

FIG. 6 is a front elevation view thereof; and,

FIG. 7 is a rear elevation view.

(56) **References Cited**

The Flaskar embodiments of the present invention provide a specially designed Flask for racing events, parties, and other get-togethers for fans and groups, and individuals. The device can be used as a Flask or Water Bottle and be kept as a souvenir and for future use. It should be recognized that embodiments of the design have the following unique items:

U.S. PATENT DOCUMENTS

D359,090	S	*	6/1995	Van Der Hoeven	D3/202
D451,272	S	*	12/2001	McFarlin	D3/202
D477,132	S	*	7/2003	Bond et al.	D3/202
D488,919	S	*	4/2004	Hurlbut	D3/202
D524,536	S	*	7/2006	Warner	D3/202
D569,097	S	*	5/2008	Leslie et al.	D3/202

The Flaskar will be shaped like a race car with a realistic appearance. The screw on/off top will have the appearance of a race car steering wheel.

* cited by examiner

1 Claim, 2 Drawing Sheets

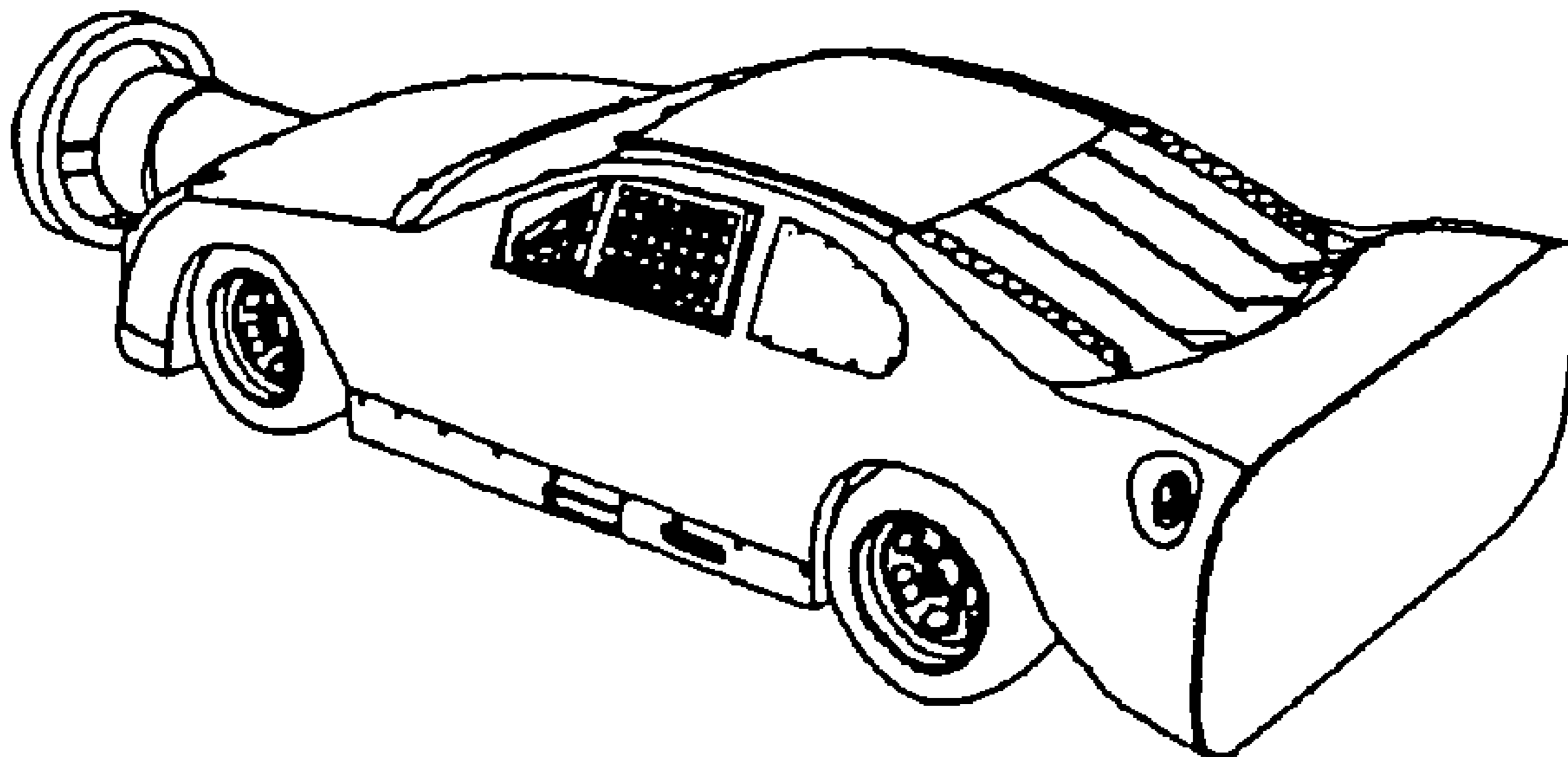

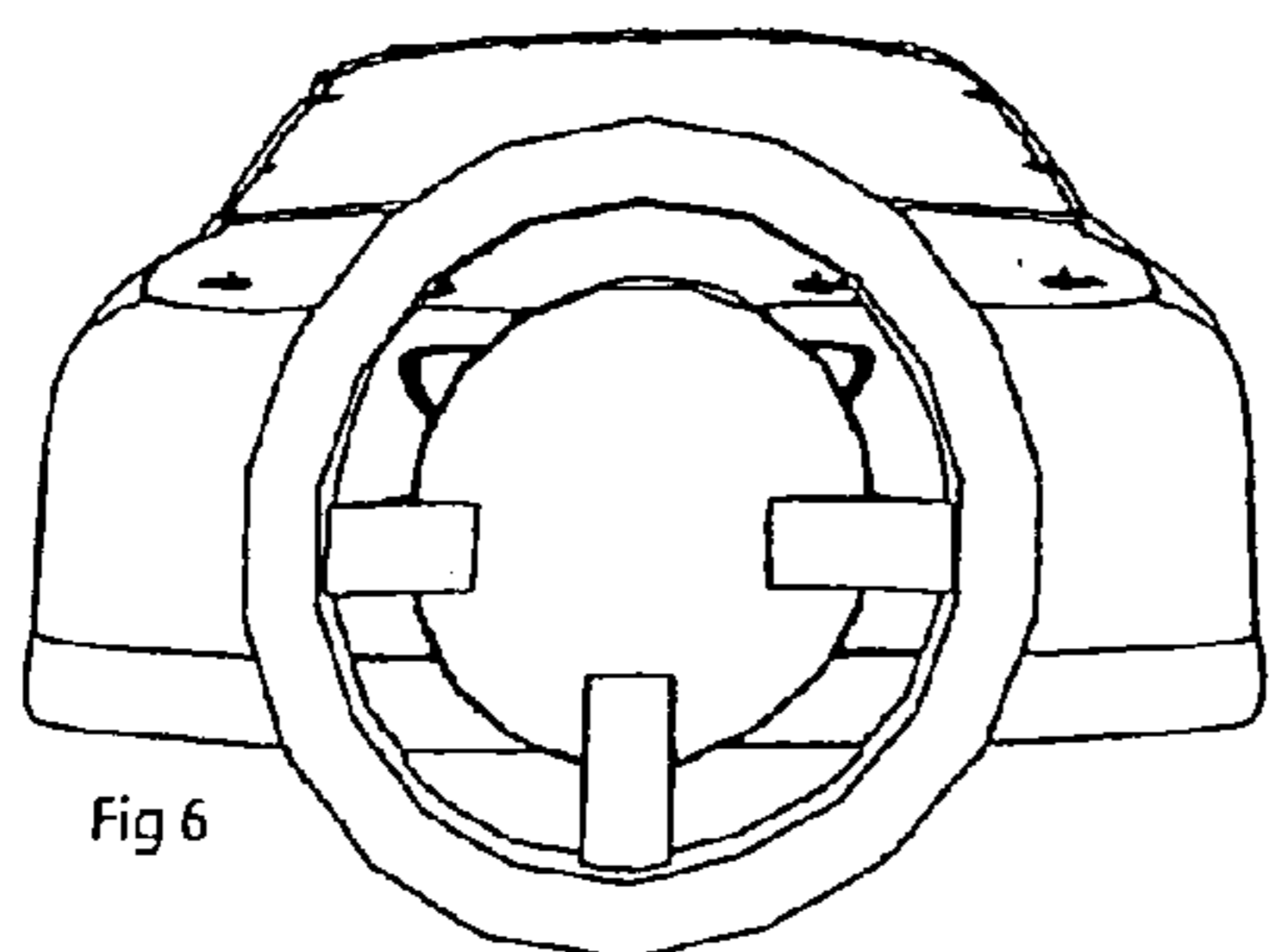
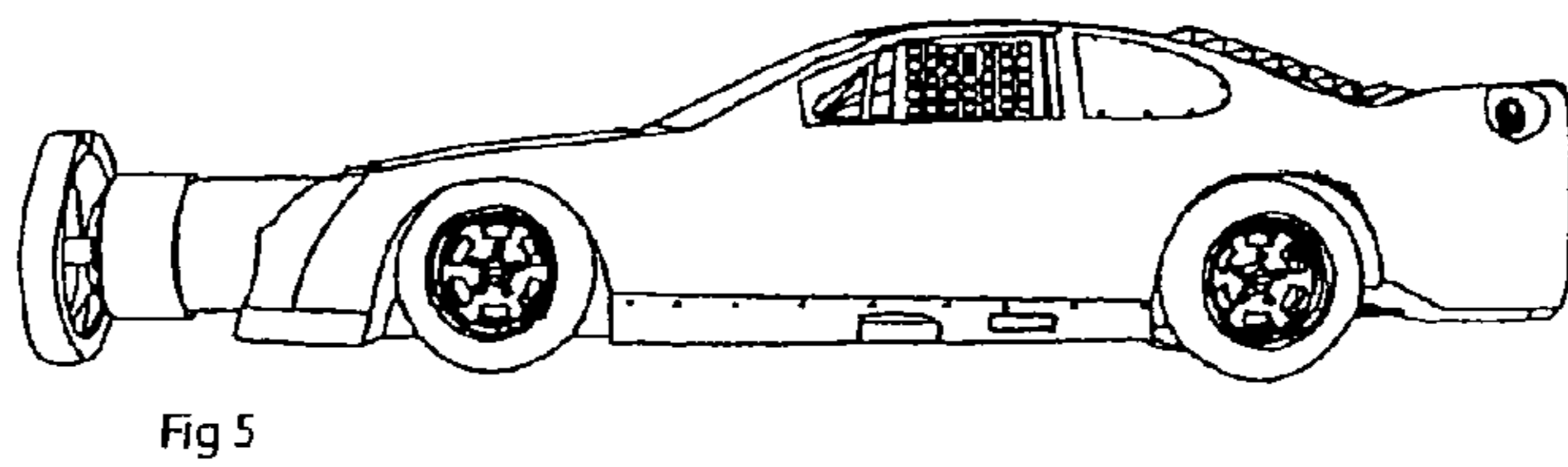
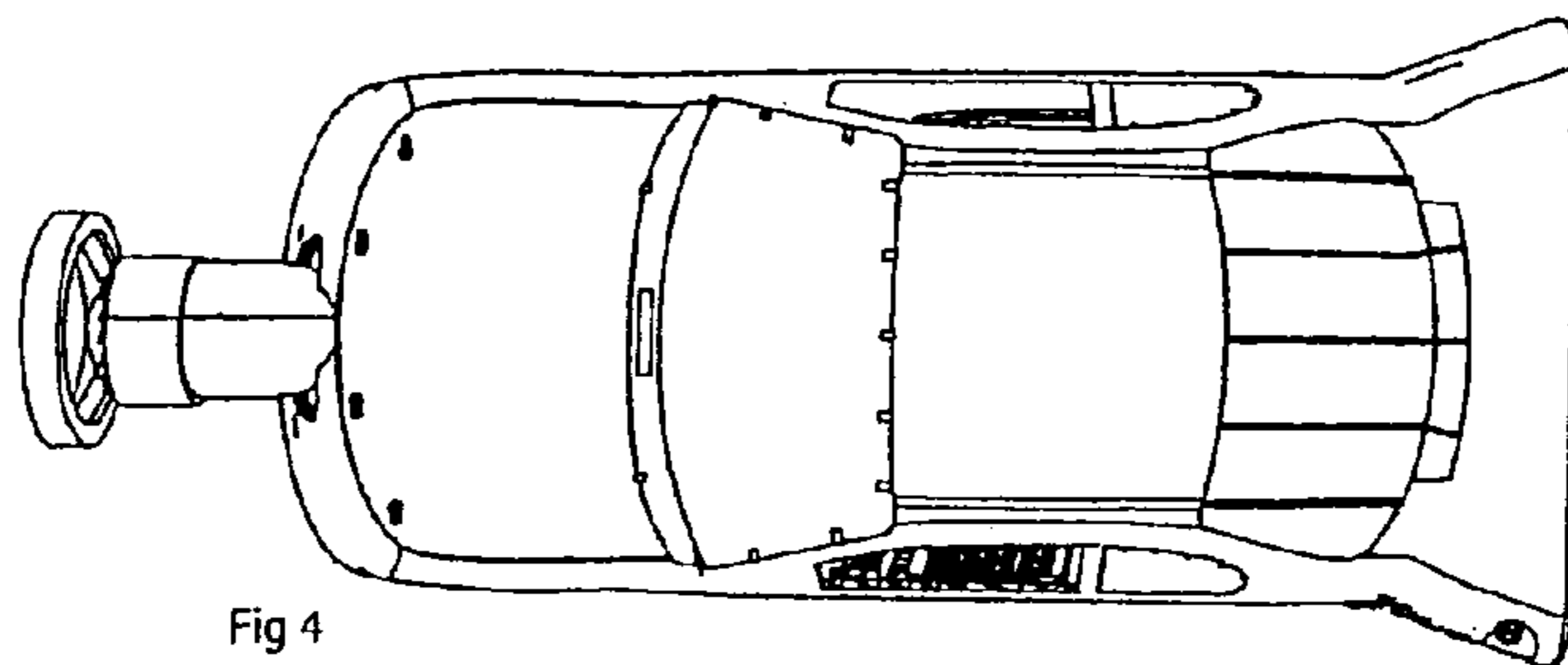
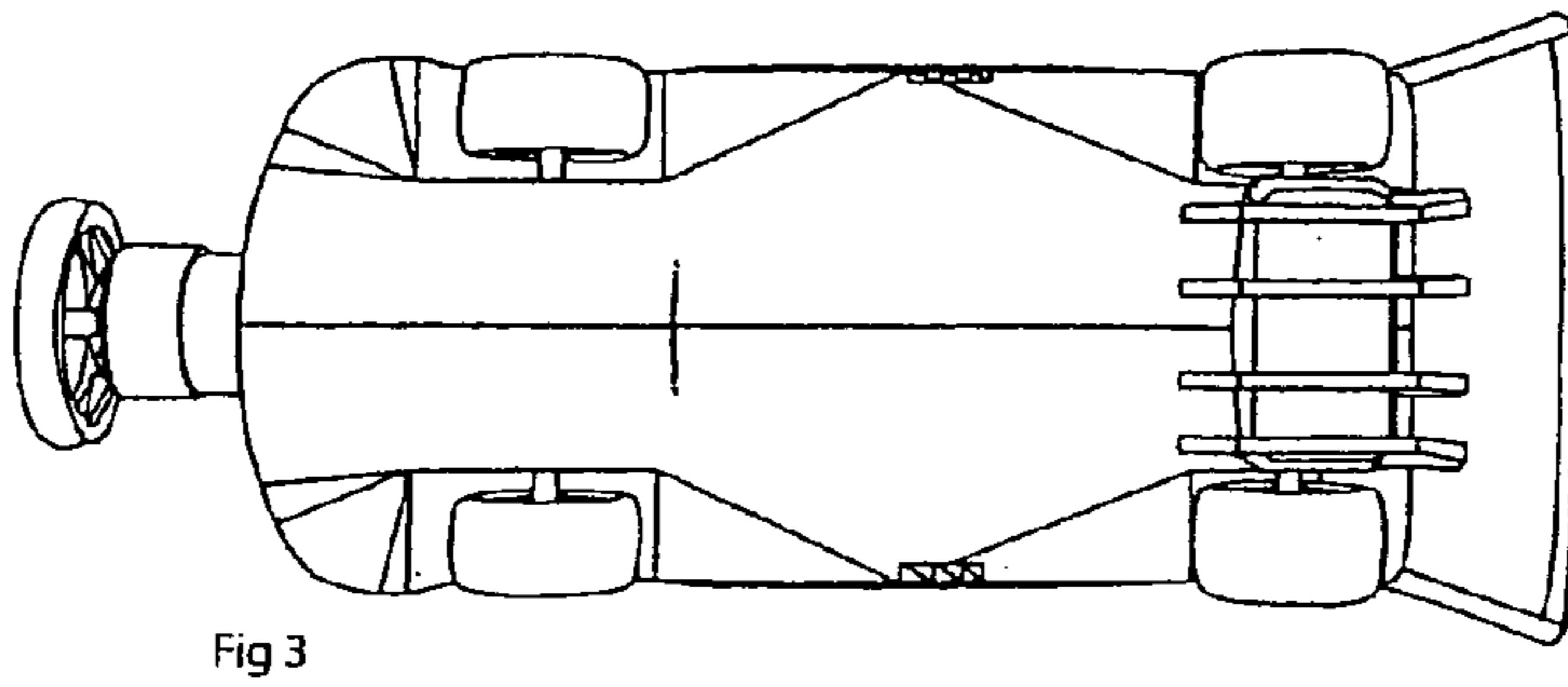
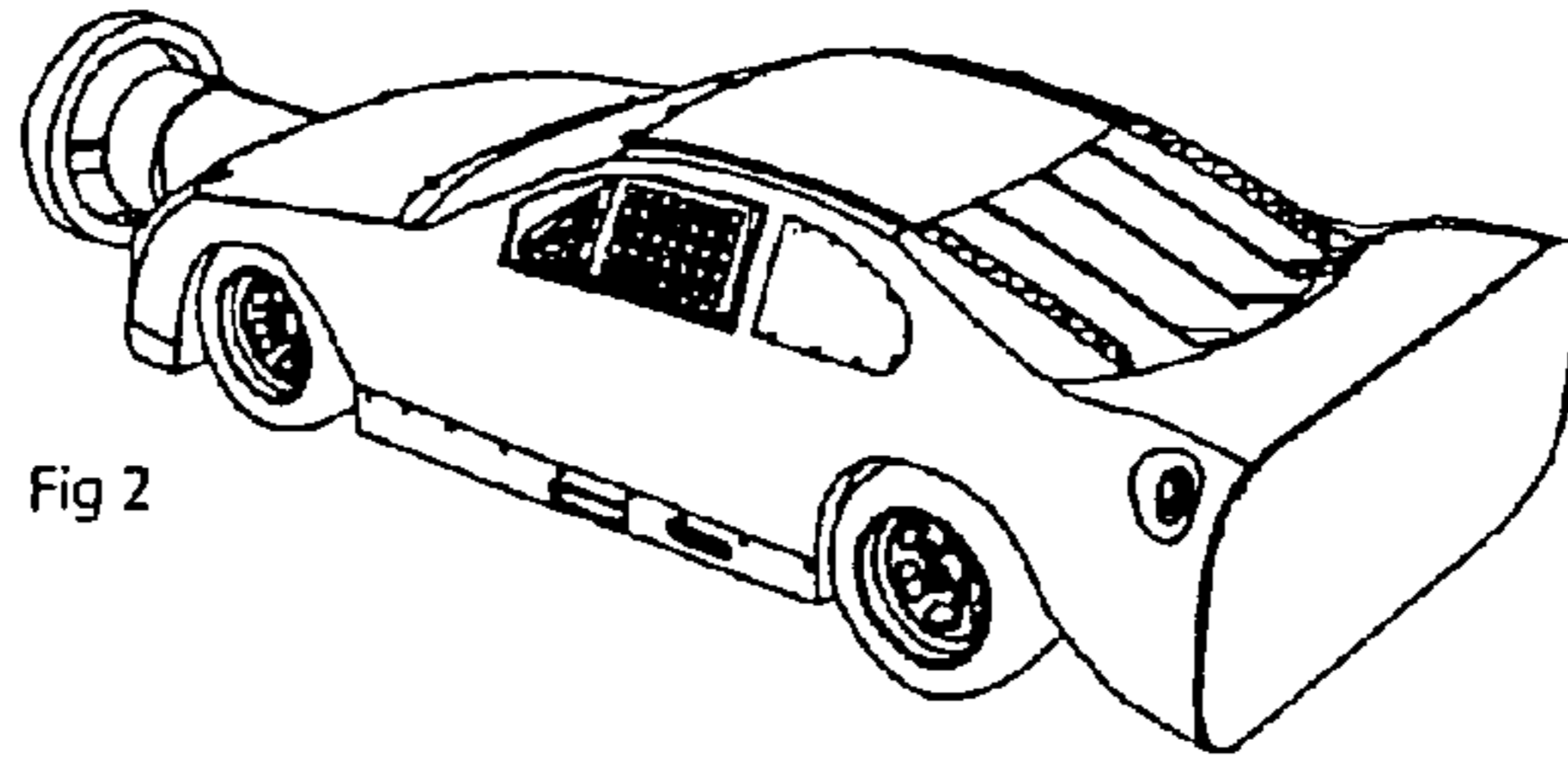
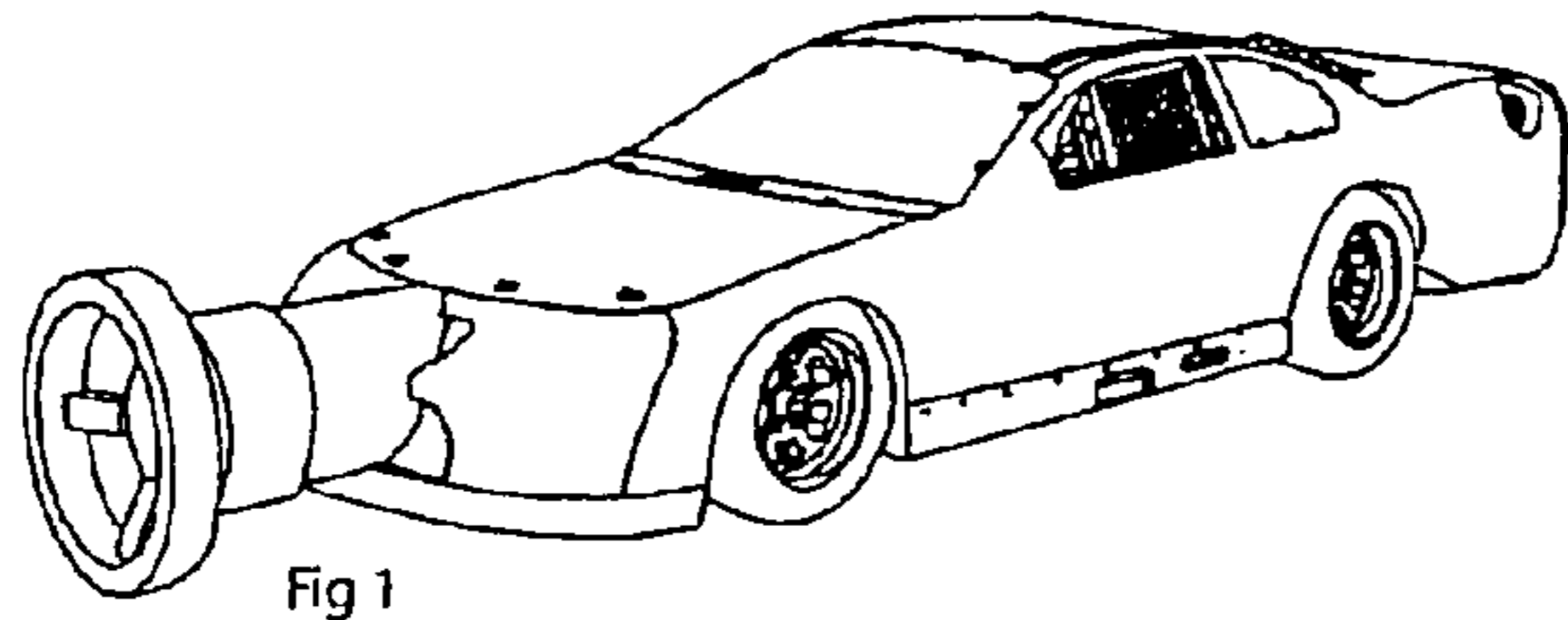

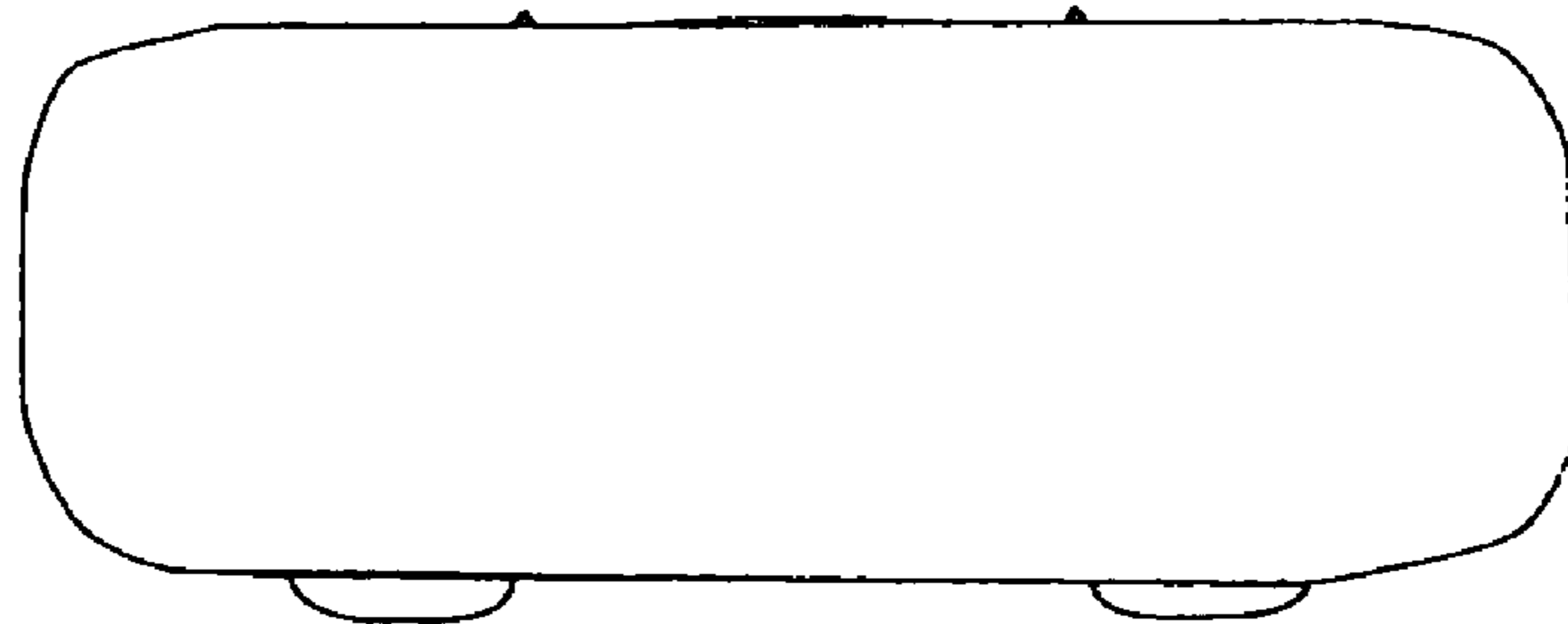

Fig 7