



US00D623252S

(12) **United States Design Patent**
Pellegrini et al.

(10) **Patent No.:** **US D623,252 S**

(45) **Date of Patent:** **** Sep. 7, 2010**

(54) **SINGLE-CAM COMPOUND BOW**

(57) **CLAIM**

(76) Inventors: **Mario Pellegrini**, P.O. Box 1356,
Montara, CA (US) 94037; **William C.**
Dahl, II, 37 Kehoe Ave., Half Moon Bay,
CA (US) 94019

The ornamental design for a single-cam compound bow, as shown and described.

(**) Term: **14 Years**

DESCRIPTION

(21) Appl. No.: **29/332,508**

FIG. 1 is a rear perspective view of a single-cam compound bow as viewed obliquely from the right behind the bow.

(22) Filed: **Feb. 18, 2009**

FIG. 2 is a left side elevation view of the single-cam compound bow with the bowstring cable undrawn.

(51) **LOC (9) Cl.** **22-01**

(52) **U.S. Cl.** **D22/107**

(58) **Field of Classification Search** D22/100,
D22/107, 199; 124/86, 88, 23.1, 25.6
See application file for complete search history.

FIG. 3 is a right side elevation view of the single-cam compound bow with the bowstring cable undrawn.

FIG. 4 is a left side elevation view of the single-cam compound bow with the bowstring cable drawn.

FIG. 5 is a right side elevation view of the single-cam compound bow with the bowstring cable drawn.

(56) **References Cited**

U.S. PATENT DOCUMENTS

4,674,468	A *	6/1987	Izuta	124/23.1
5,433,792	A *	7/1995	Darlington	124/25.6
5,803,070	A *	9/1998	Martin et al.	124/88
6,321,736	B1 *	11/2001	McPherson	124/25.6
D533,250	S *	12/2006	Sims et al.	D22/107
7,258,113	B2 *	8/2007	Pilpel et al.	124/23.1
7,574,811	B2 *	8/2009	Kurtzhals et al.	33/265
7,690,372	B2 *	4/2010	Cooper et al.	124/25.6
7,699,045	B1 *	4/2010	Kronengold et al.	124/25.6

FIG. 6 is a front elevation view of the single-cam compound bow.

FIG. 7 is a rear elevation view of the single-cam compound bow.

FIG. 8 is a top plan view of the single-cam compound bow.

FIG. 9 is a bottom plan view of the single-cam compound bow.

FIG. 10 is a left side elevation view of the single-cam compound bow with the bow-limb bolt adjusted for a low draw-weight (force) with the bowstring cable undrawn; and,

FIG. 11 is a left side elevation view of the single-cam compound bow with the bow-limb bolt adjusted for a high draw-weight (force) with the bowstring cable undrawn.

* cited by examiner

Primary Examiner—T. Chase Nelson

Assistant Examiner—Michael A Pratt

(74) *Attorney, Agent, or Firm*—David E. Newhouse, Esq

1 Claim, 9 Drawing Sheets

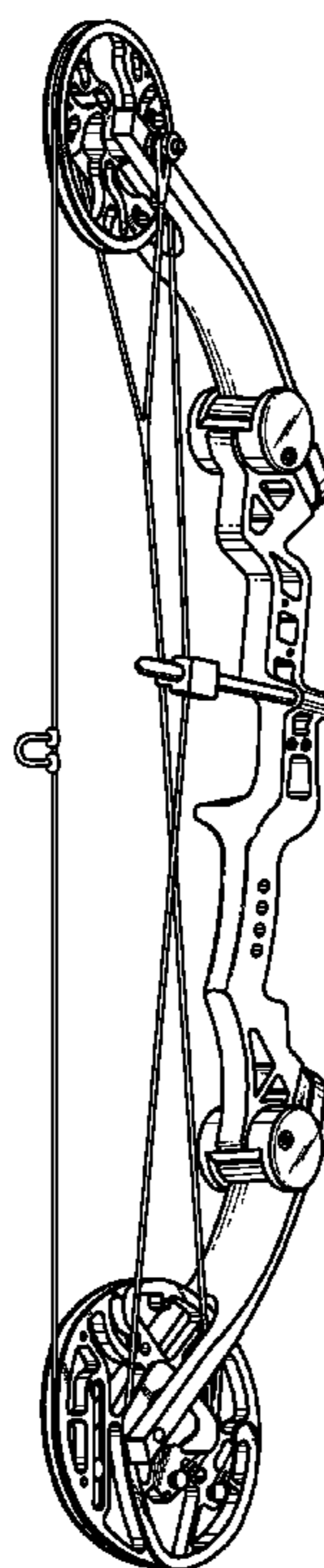

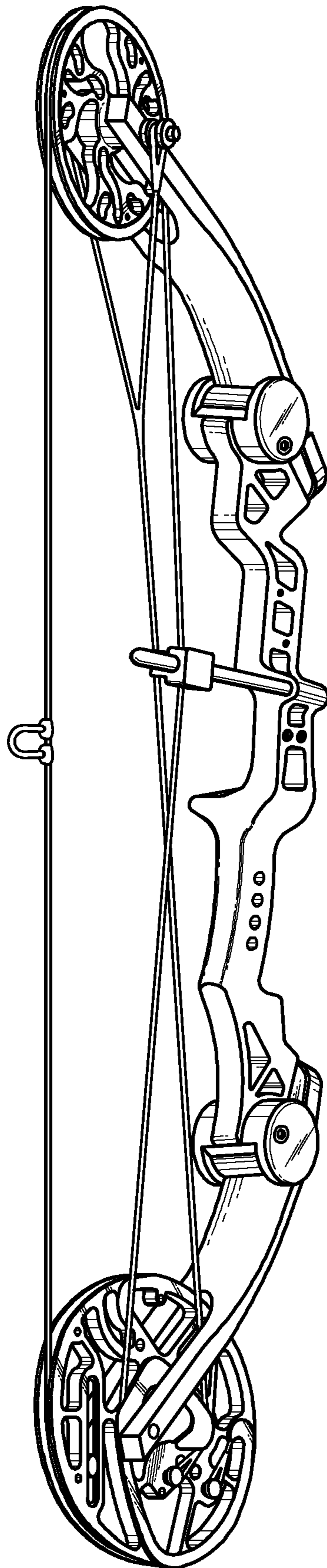

FIG.1

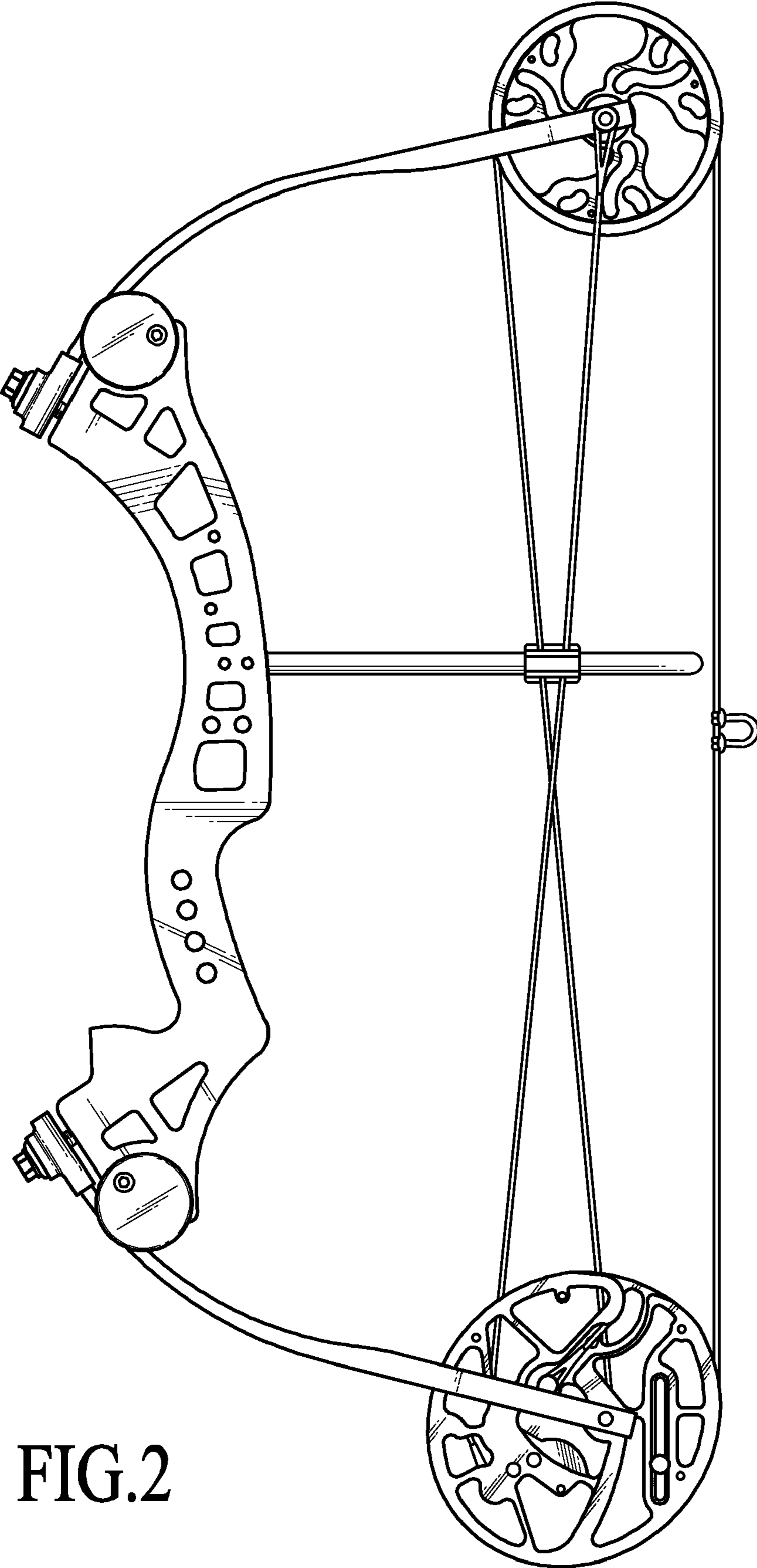

FIG. 2

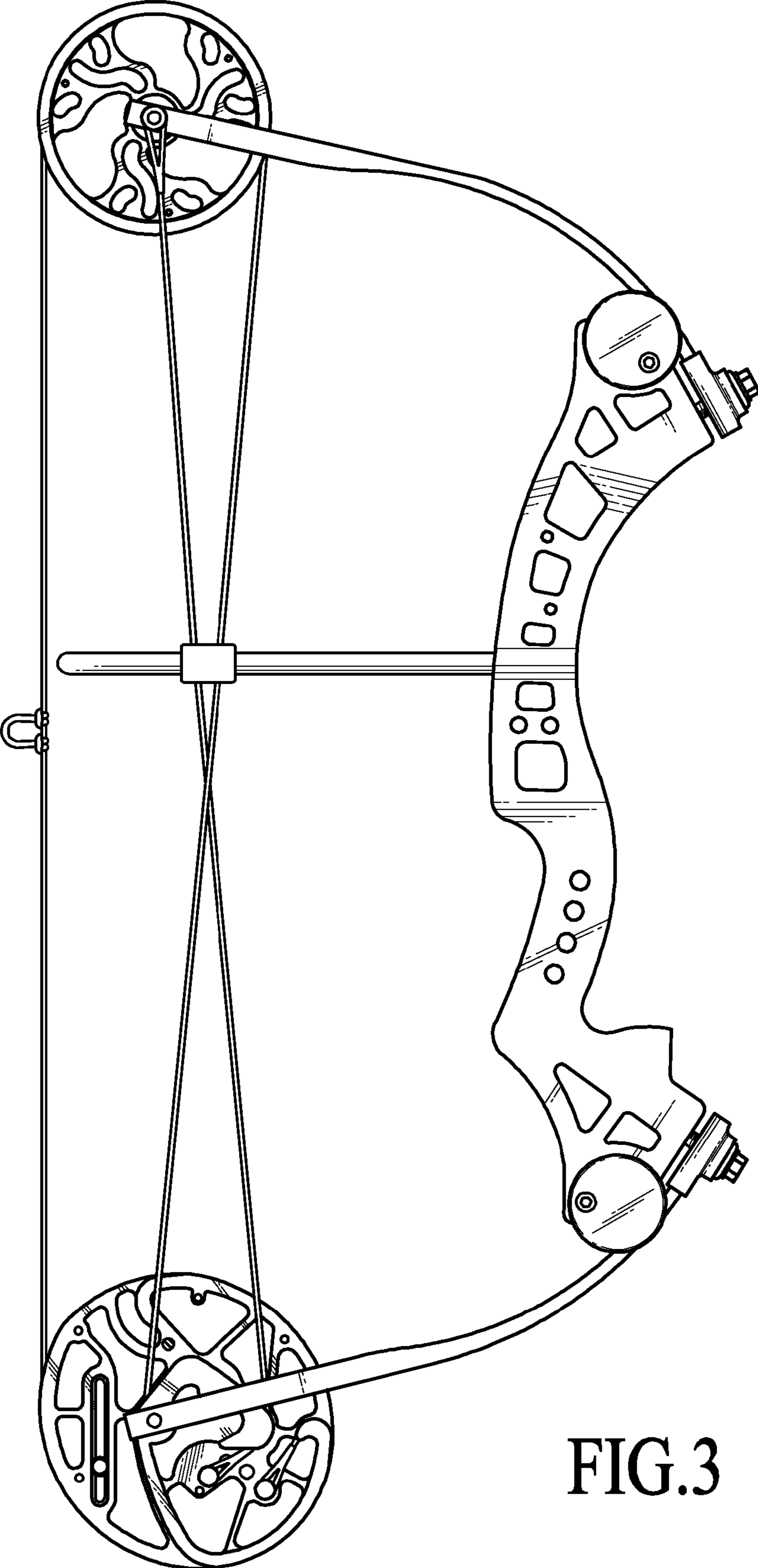

FIG.3

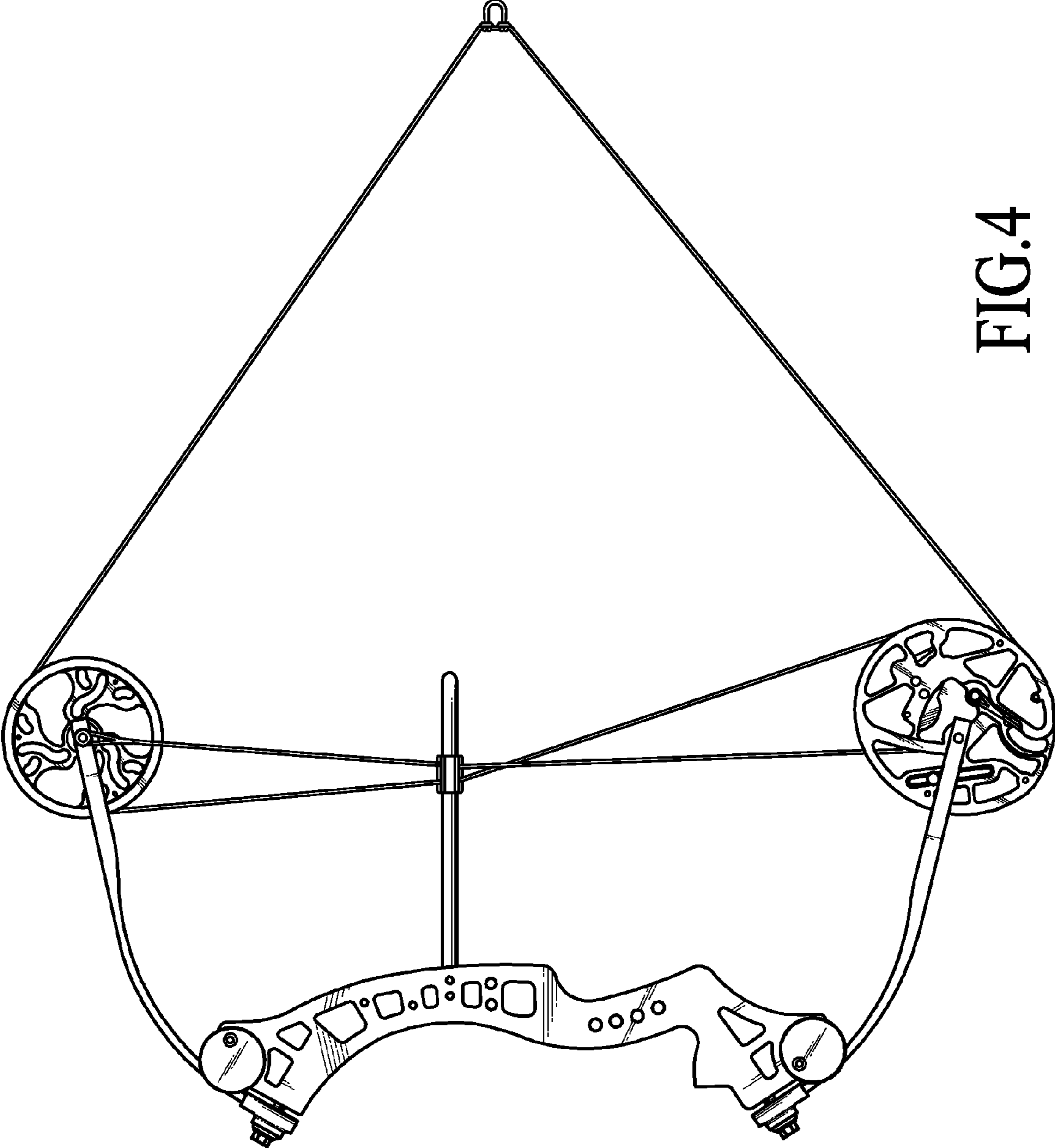

FIG. 4

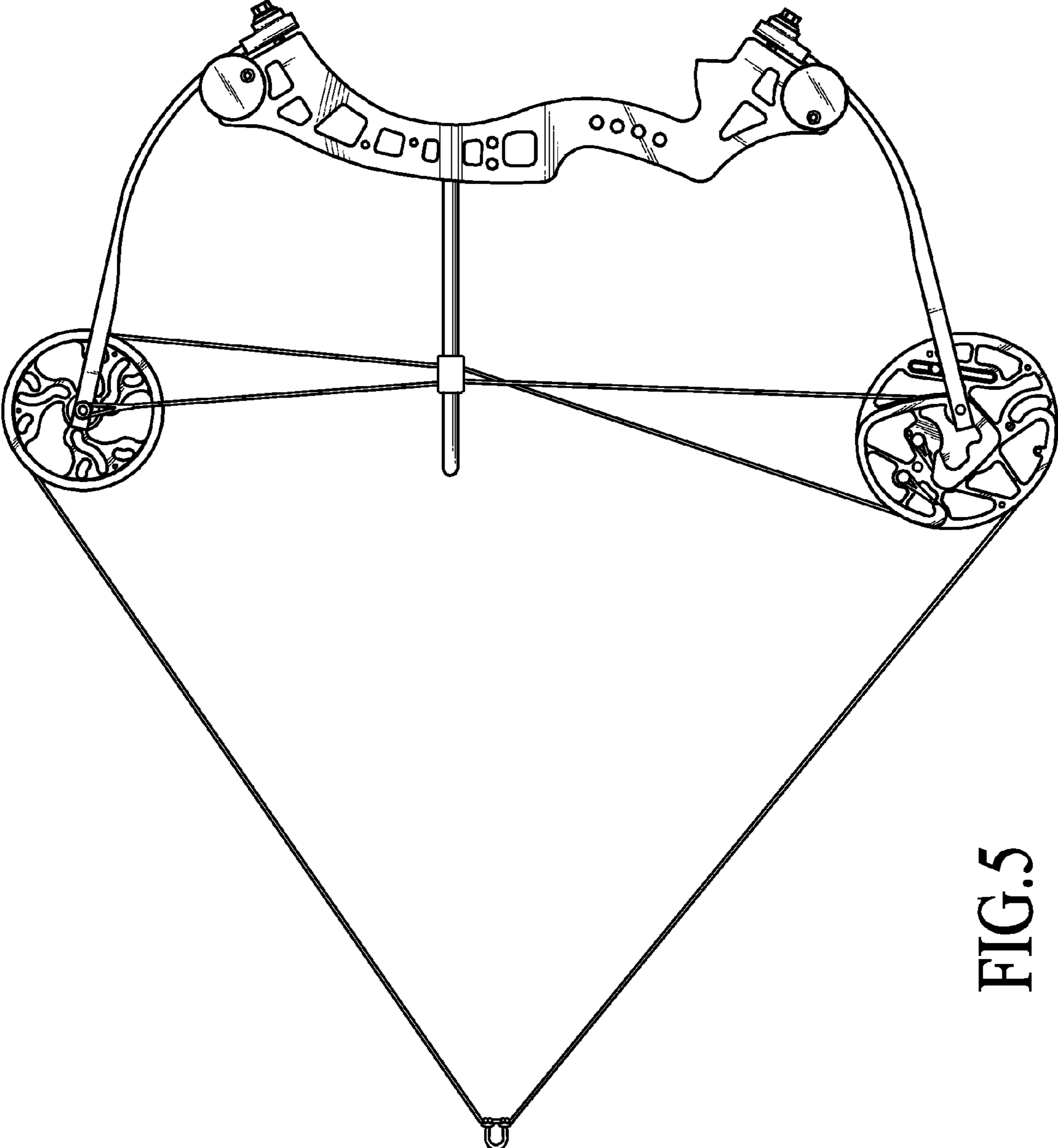
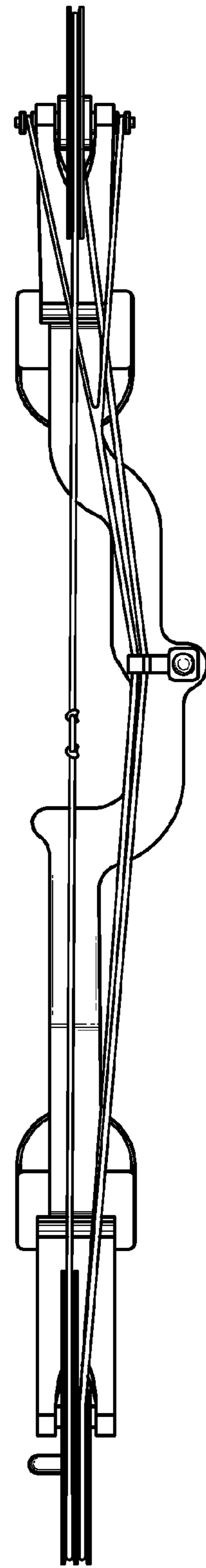
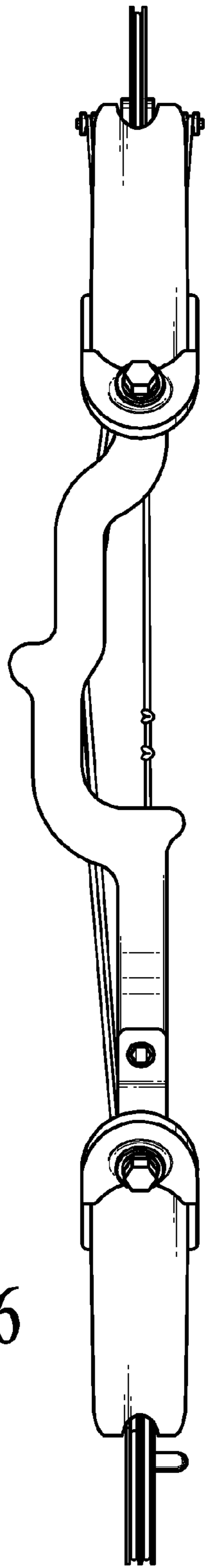

FIG.5



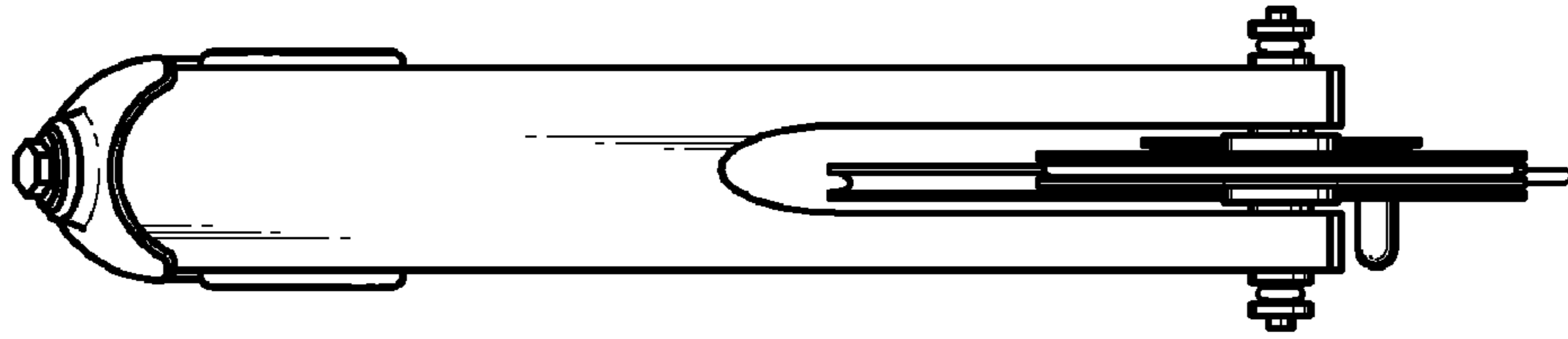

FIG. 8

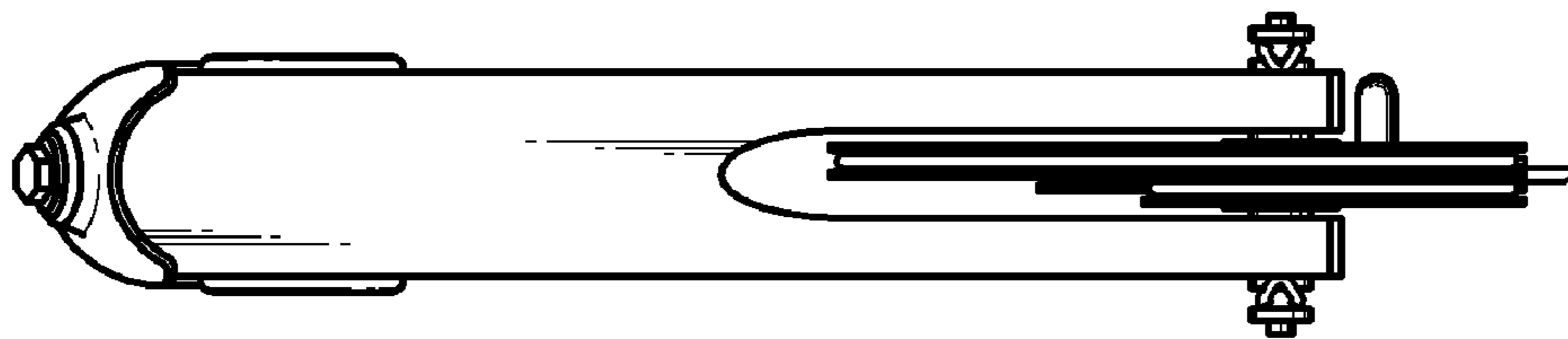

FIG. 9

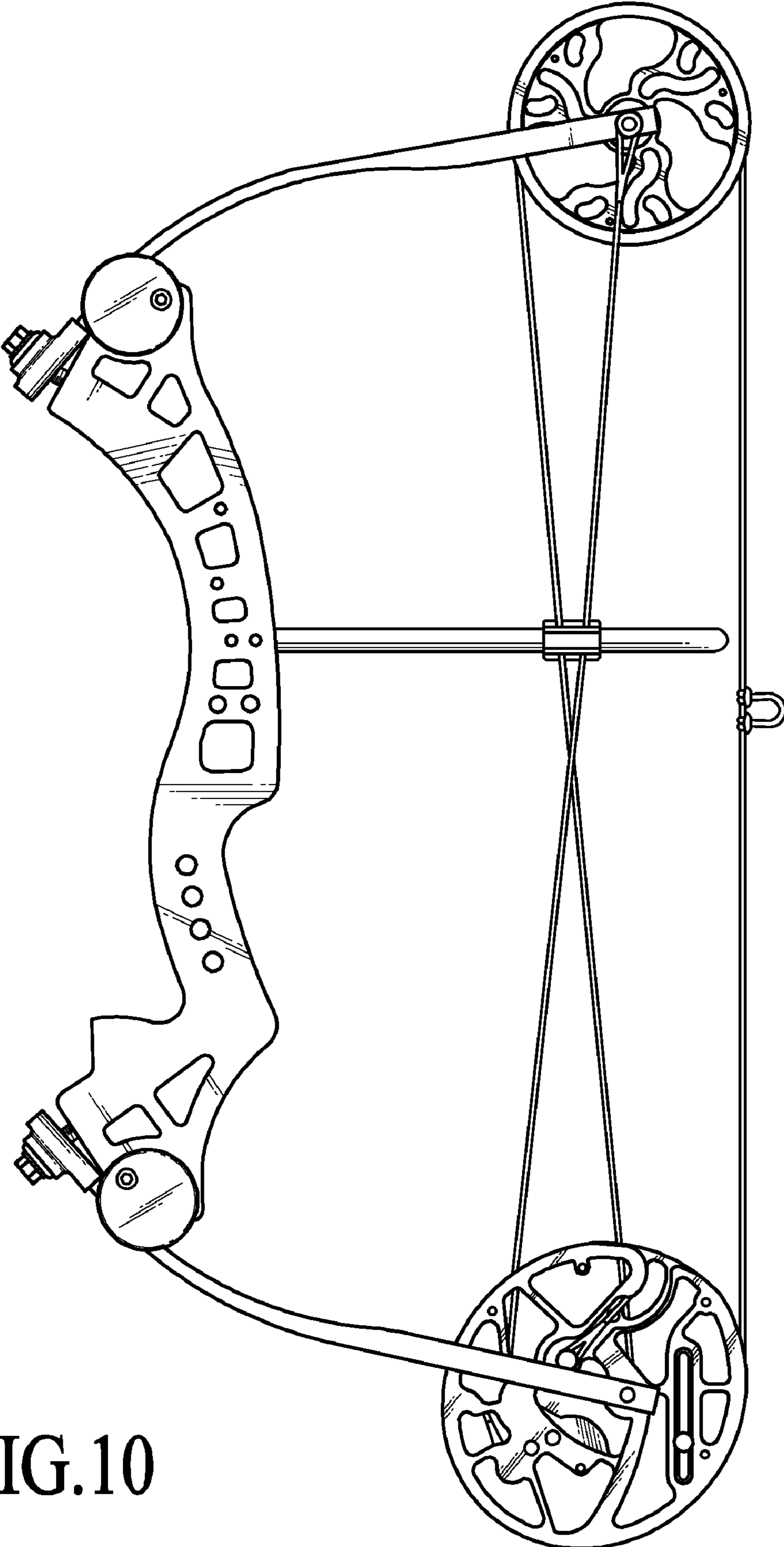

FIG.10

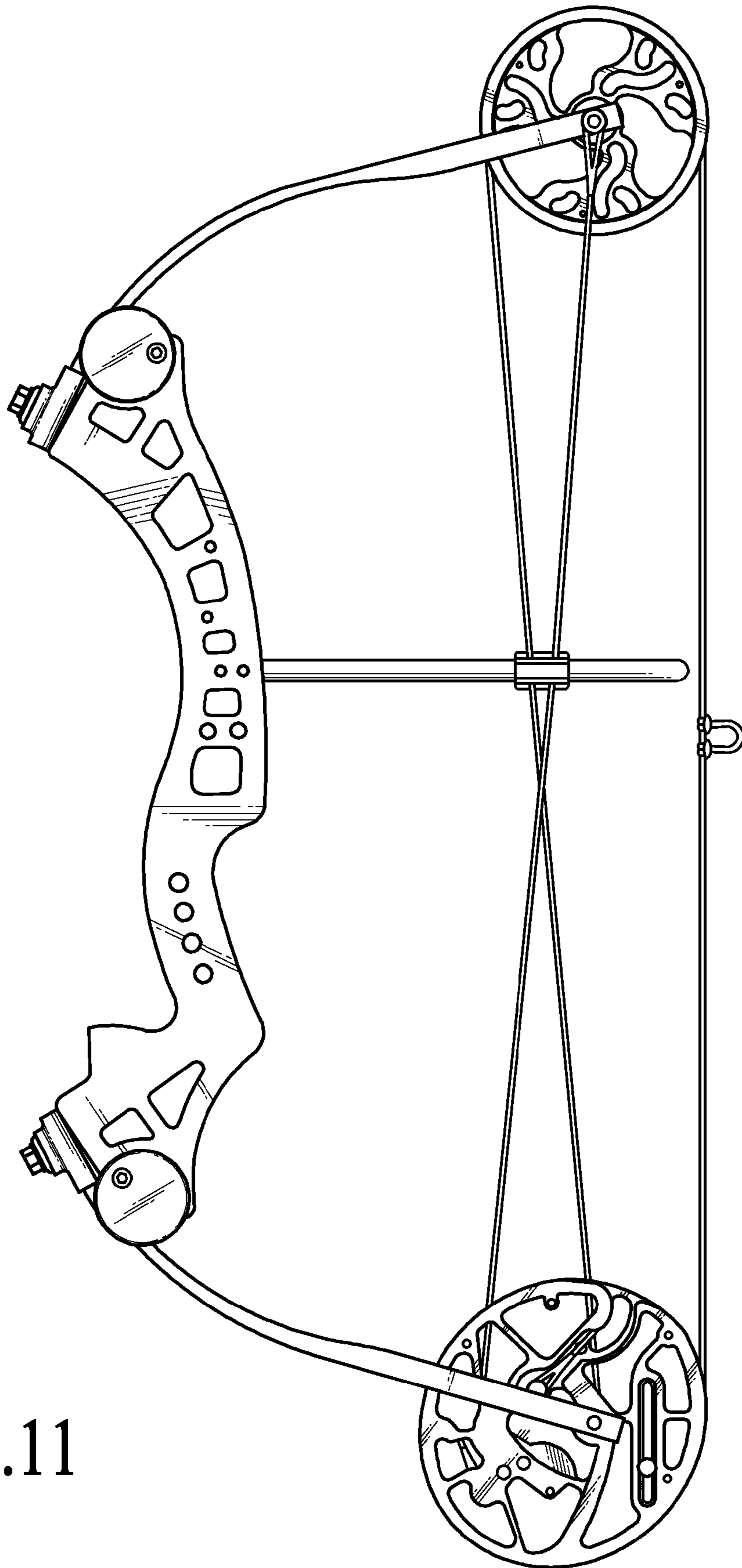

FIG.11