



US00D623117S

(12) **United States Design Patent**
Farber

(10) **Patent No.:** **US D623,117 S**

(45) **Date of Patent:** **** Sep. 7, 2010**

(54) **BICYCLE CARRIER**

(76) Inventor: **Robert Farber**, 2 Gayton Rd., Montreal,
Quebec (CA) H3X 1K7

(**) Term: **14 Years**

(21) Appl. No.: **29/355,925**

(22) Filed: **Feb. 17, 2010**

(51) **LOC (9) Cl.** **12-11**

(52) **U.S. Cl.** **D12/408**

(58) **Field of Classification Search** D12/408,
D12/407, 412, 155, 120; 224/400, 412, 42.11,
224/924, 500-511, 522-537, 309-331, 42.12,
224/42.13; 211/5, 17-22; 280/769; 296/3
See application file for complete search history.

(56) **References Cited**

U.S. PATENT DOCUMENTS

4,452,384	A *	6/1984	Graber	224/314
4,524,893	A *	6/1985	Cole	224/319
4,702,401	A *	10/1987	Graber et al.	224/536
5,456,396	A *	10/1995	Allen	224/321
6,296,162	B1 *	10/2001	Englander et al.	224/324
D460,401	S *	7/2002	Andersson	D12/408
6,439,397	B1 *	8/2002	Reeves	211/17
6,868,998	B2 *	3/2005	Dean	224/324
D561,680	S *	2/2008	Foley et al.	D12/408
D562,217	S *	2/2008	Davis et al.	D12/408
D562,218	S *	2/2008	Foley et al.	D12/408
D566,034	S *	4/2008	Davis et al.	D12/408
7,481,344	B2 *	1/2009	Naslund et al.	224/319

OTHER PUBLICATIONS

Roof Mounted Bike Racks sold by Bike Racks Plus [Retrieved on
Mar. 20, 1997]. Retrieved from the Internet <URL: http://www.bike-racks-plus.com/Roof_Mounted_Bike_Racks_y.htm>.*

* cited by examiner

Primary Examiner—Susan M Lee
Assistant Examiner—Linda G. Brooks

(74) *Attorney, Agent, or Firm*—Husch Blackwell Sanders
LLP

(57) **CLAIM**

The ornamental design for a bicycle carrier, as shown and
described.

DESCRIPTION

FIG. 1 is a perspective view of one embodiment of the bicycle
carrier showing the new design with the support arms in a
raised position;

FIG. 2 is a side elevational view of the bicycle carrier shown
in FIG. 1;

FIG. 3 is an opposite side elevational view of the bicycle
carrier shown in FIG. 1;

FIG. 4 is a front elevational view of the bicycle carrier shown
in FIG. 1;

FIG. 5 is a rear elevational view of the bicycle carrier
shown in FIG. 1;

FIG. 6 is a top plan view of the bicycle carrier shown in FIG.
1;

FIG. 7 is a bottom plan view of the bicycle carrier shown in
FIG. 1;

FIG. 8 is a perspective view of the bicycle carrier shown in
FIG. 1 with the support arms in a lowered position;

FIG. 9 is a side elevational view of the bicycle carrier shown
in FIG. 8;

FIG. 10 is an opposite side elevational view of the bicycle
carrier shown in FIG. 8;

FIG. 11 is a front elevational view of the bicycle carrier shown
in FIG. 8;

FIG. 12 is a rear elevational view of the bicycle carrier
shown in FIG. 8;

FIG. 13 is a top plan view of the bicycle carrier shown in FIG.
8; and,

FIG. 14 is a bottom plan view of the bicycle carrier shown in
FIG. 8.

1 Claim, 7 Drawing Sheets

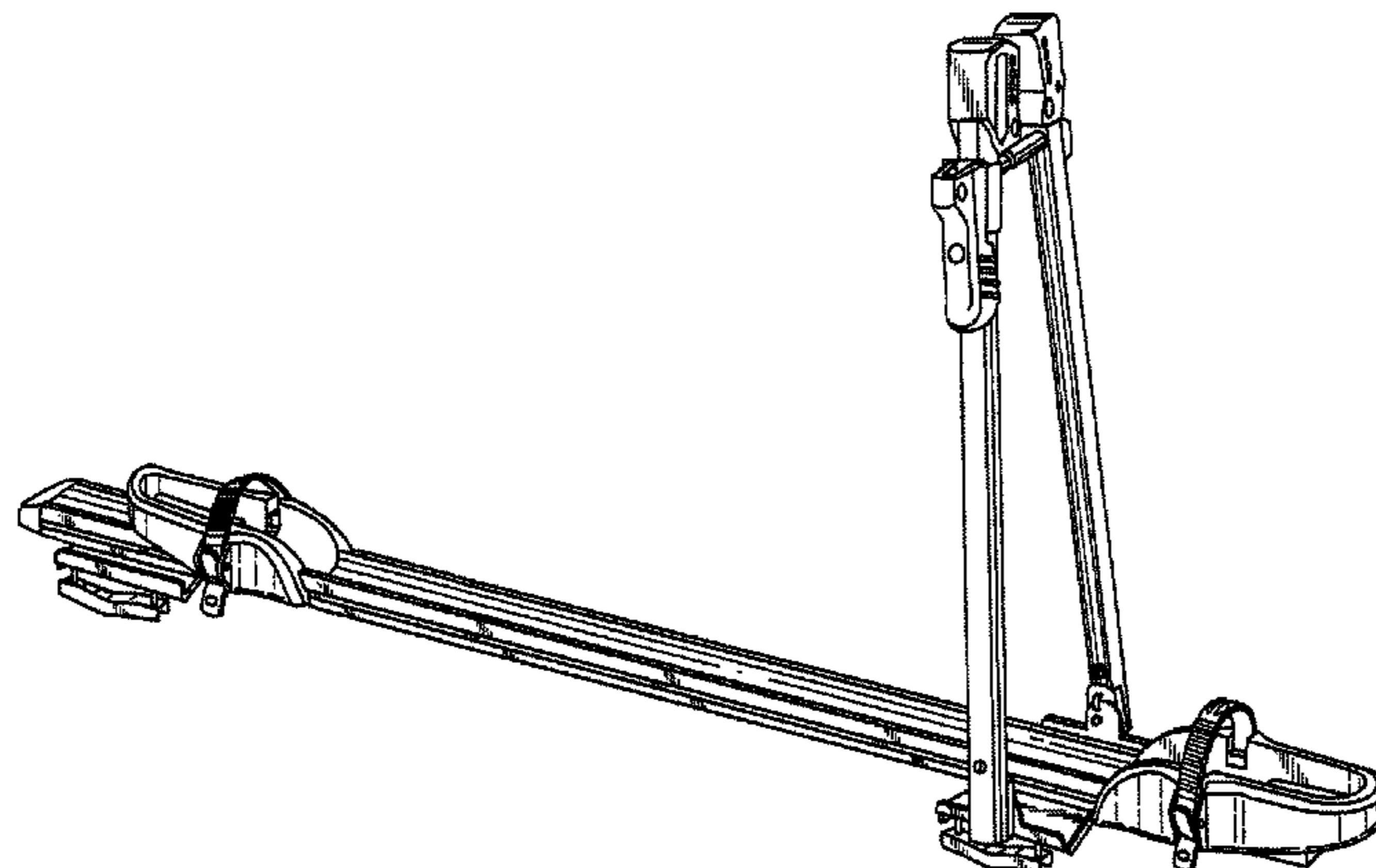

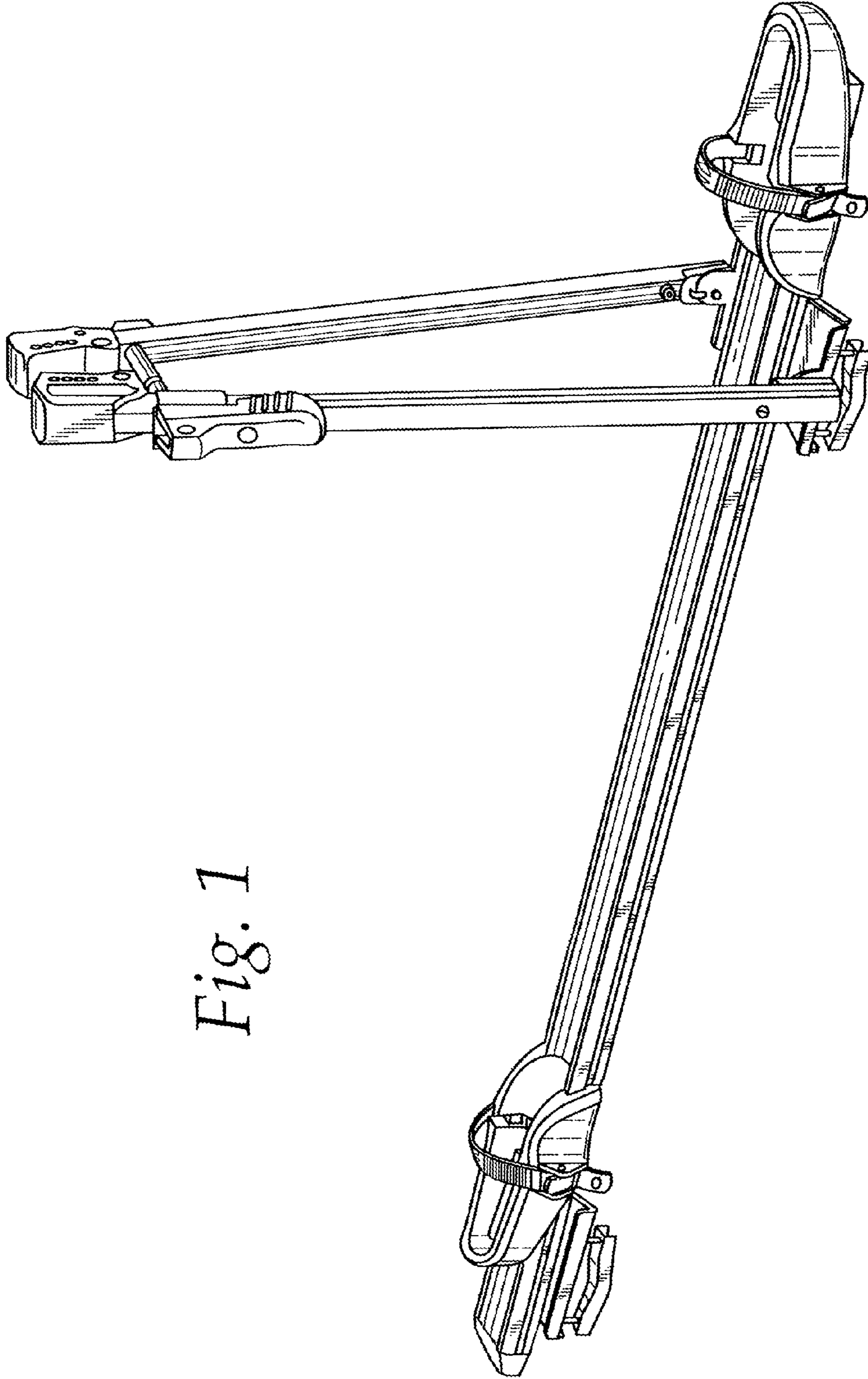
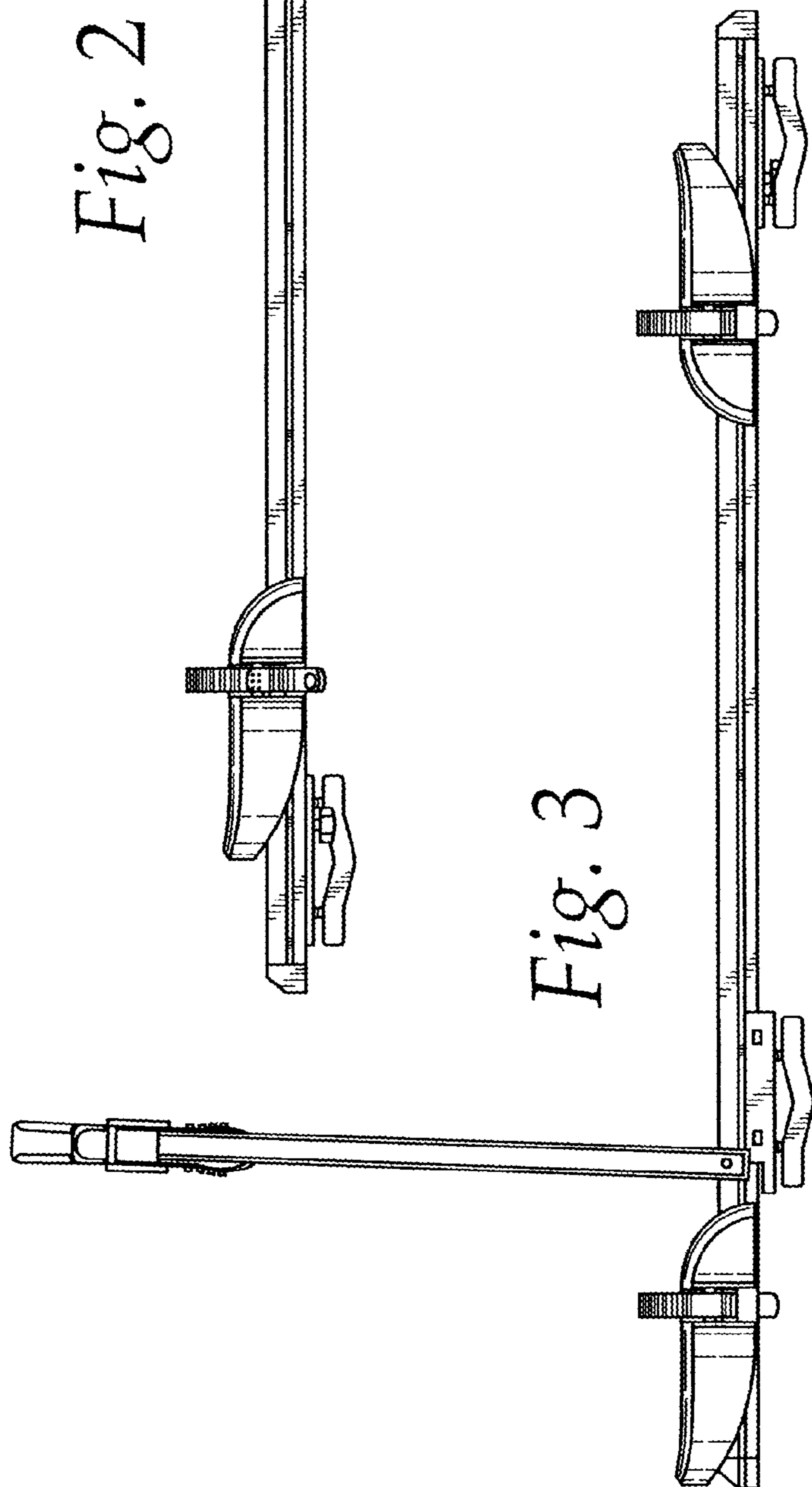
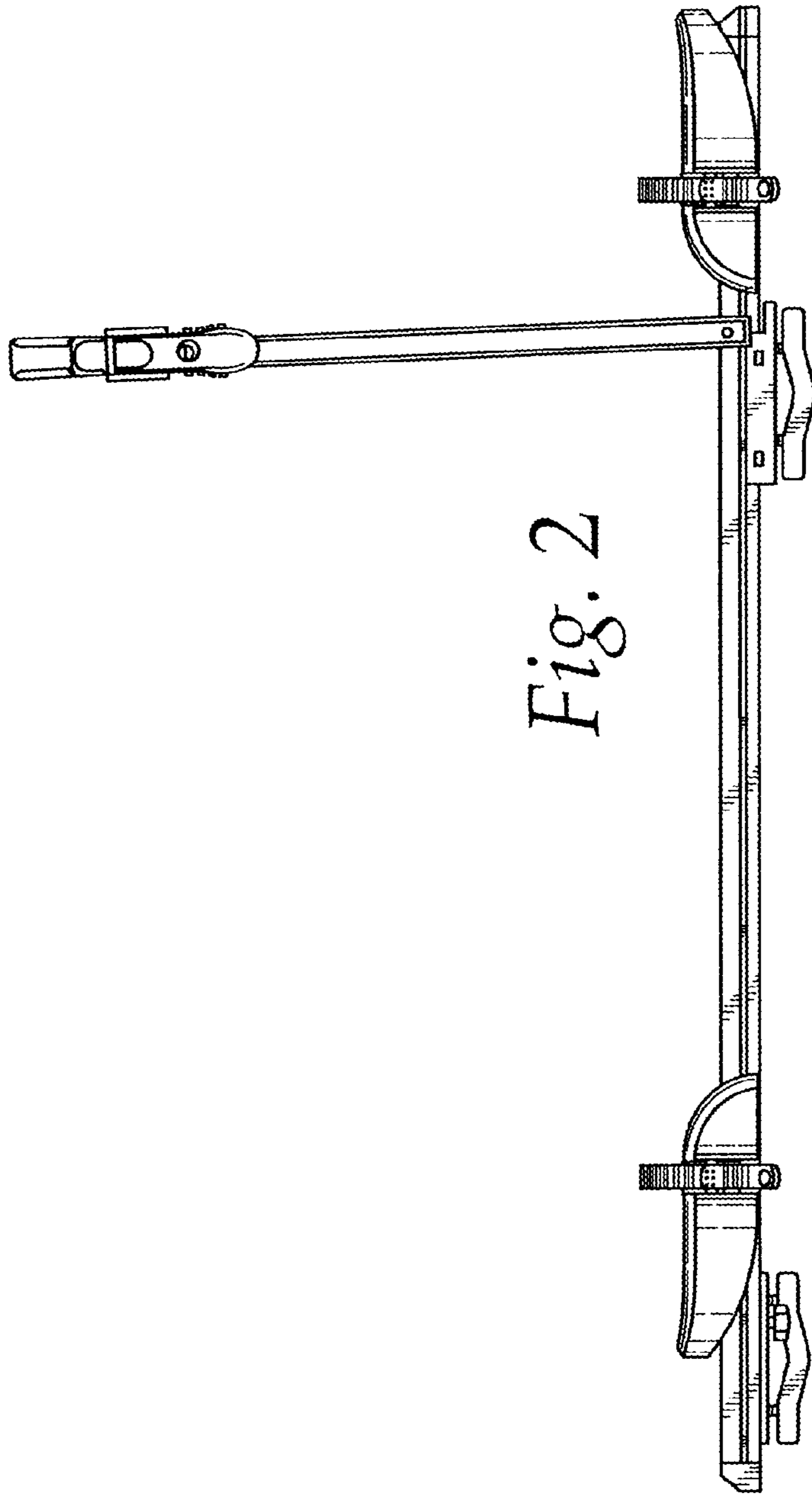

Fig. 1



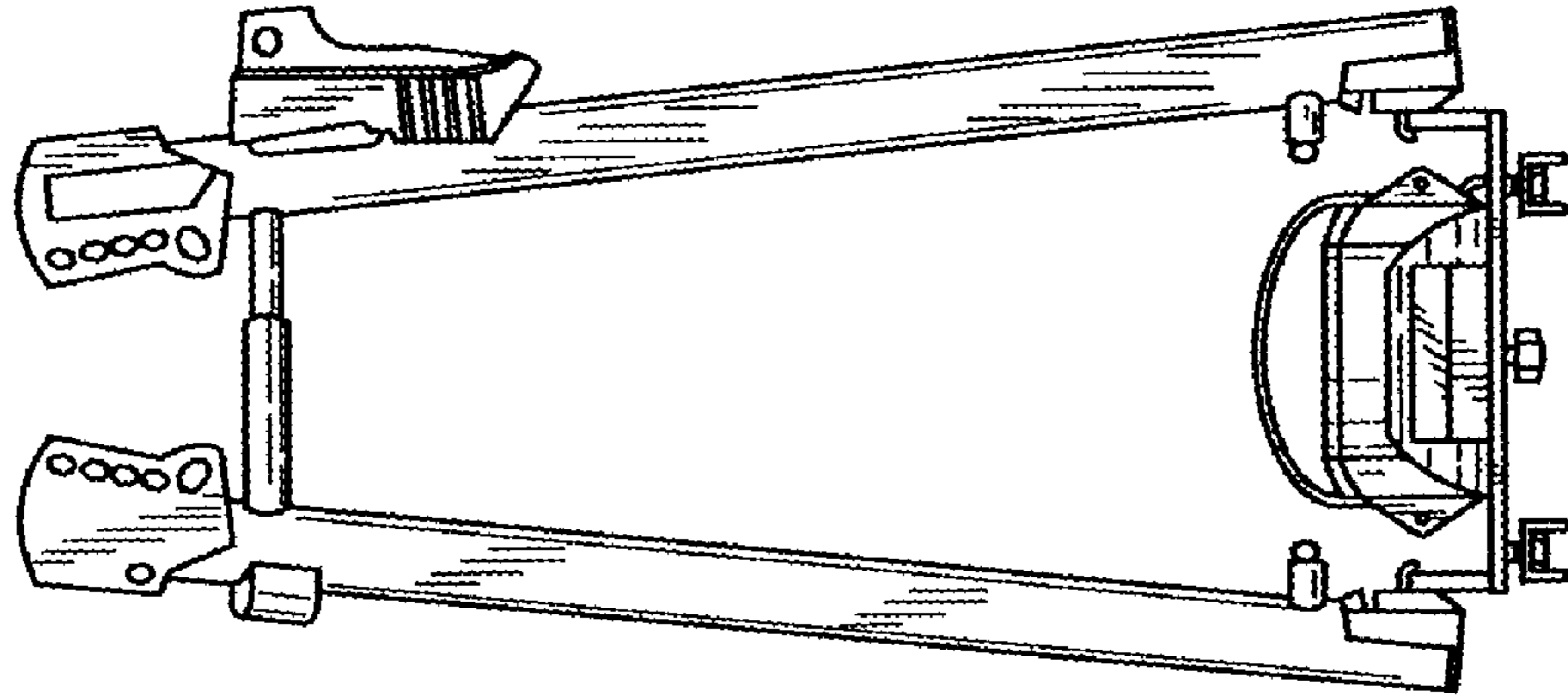

Fig. 5

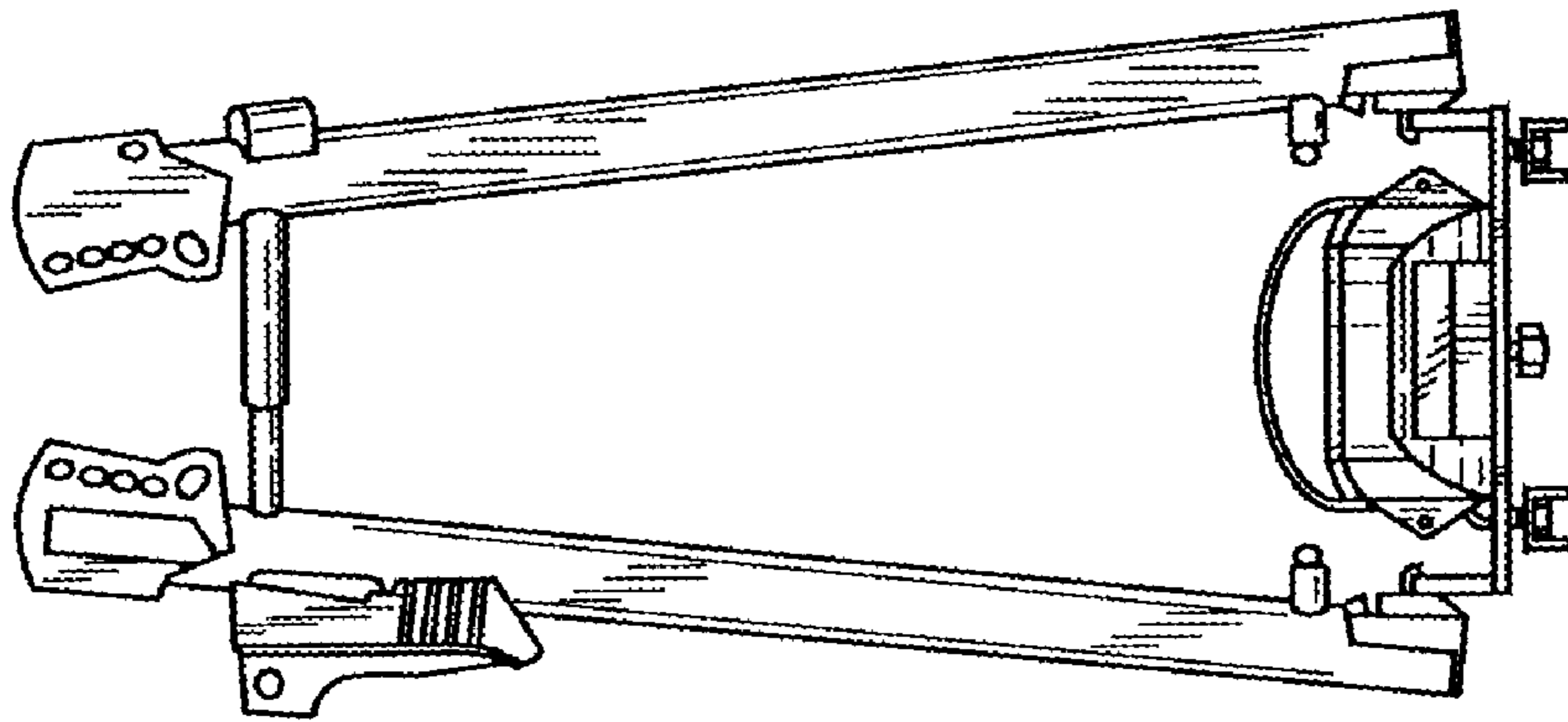

Fig. 4

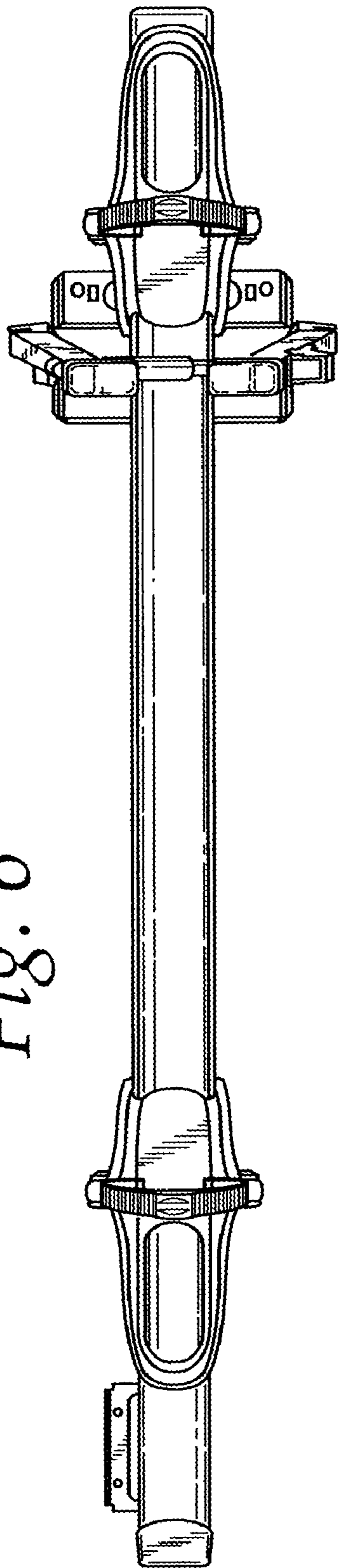

Fig. 6

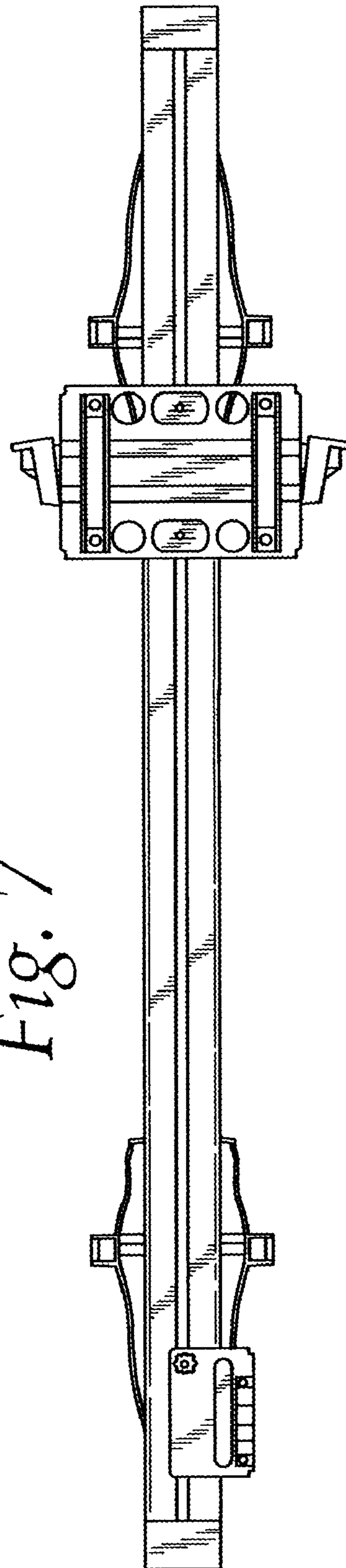

Fig. 7

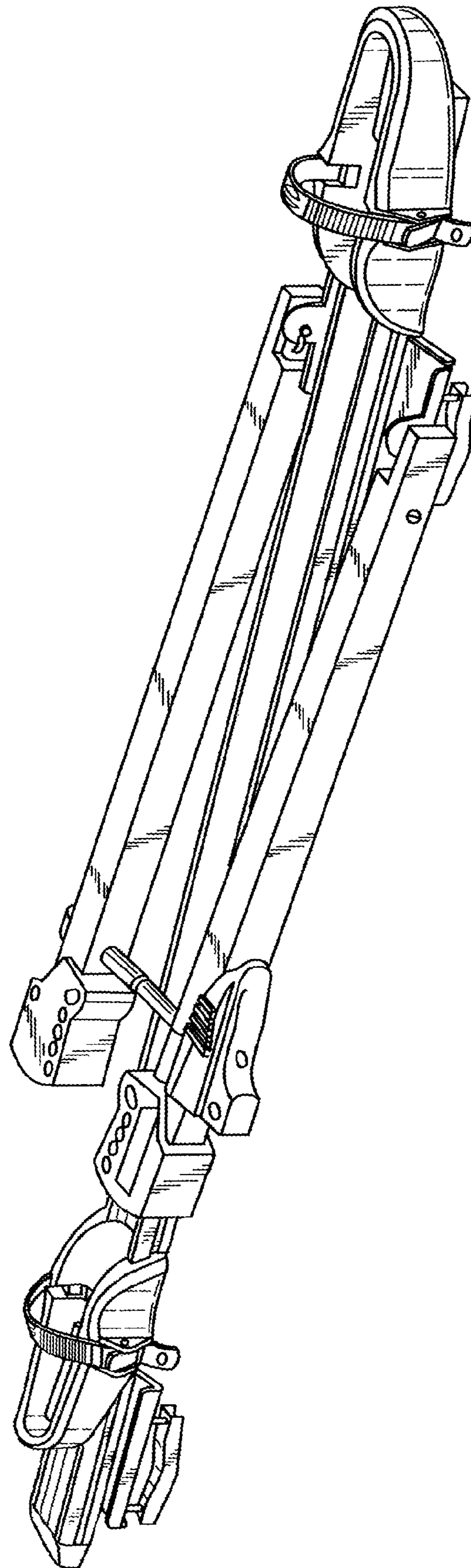

Fig. 8

Fig. 9

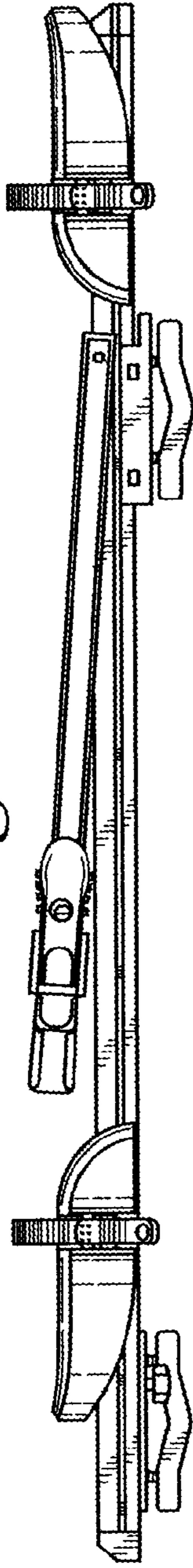

Fig. 10

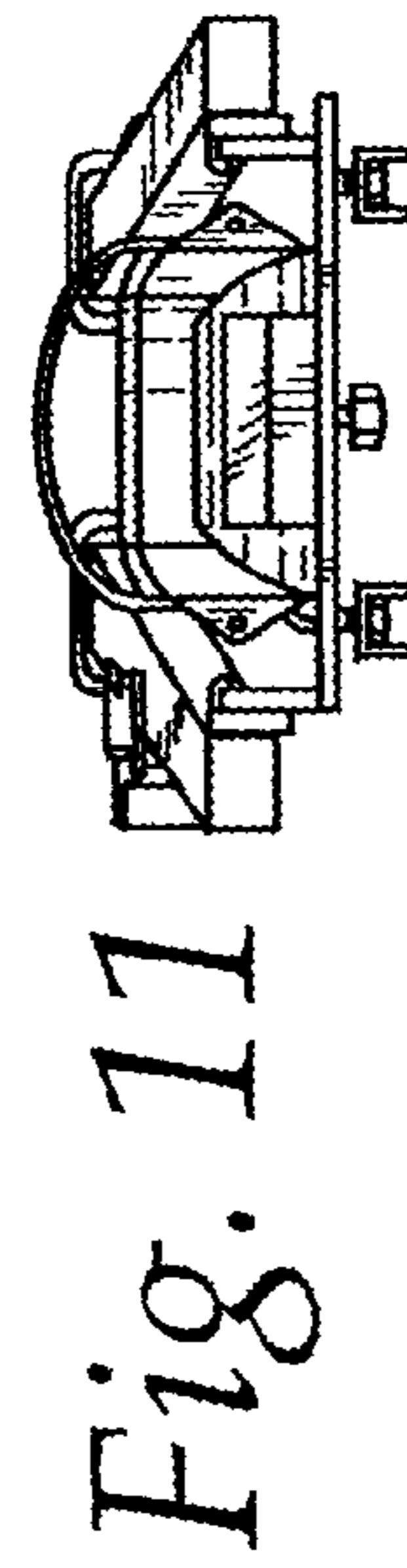
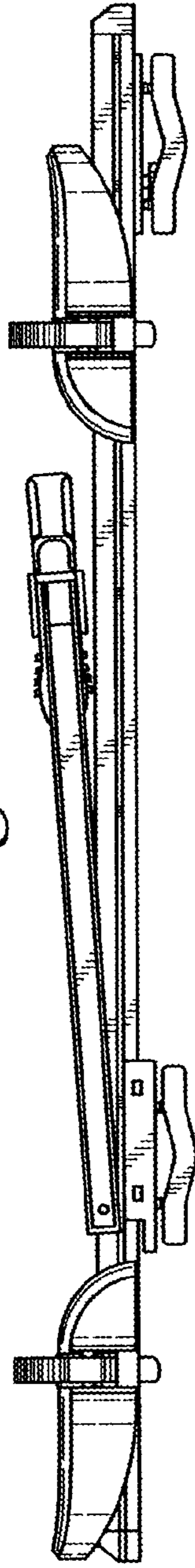

Fig. 11

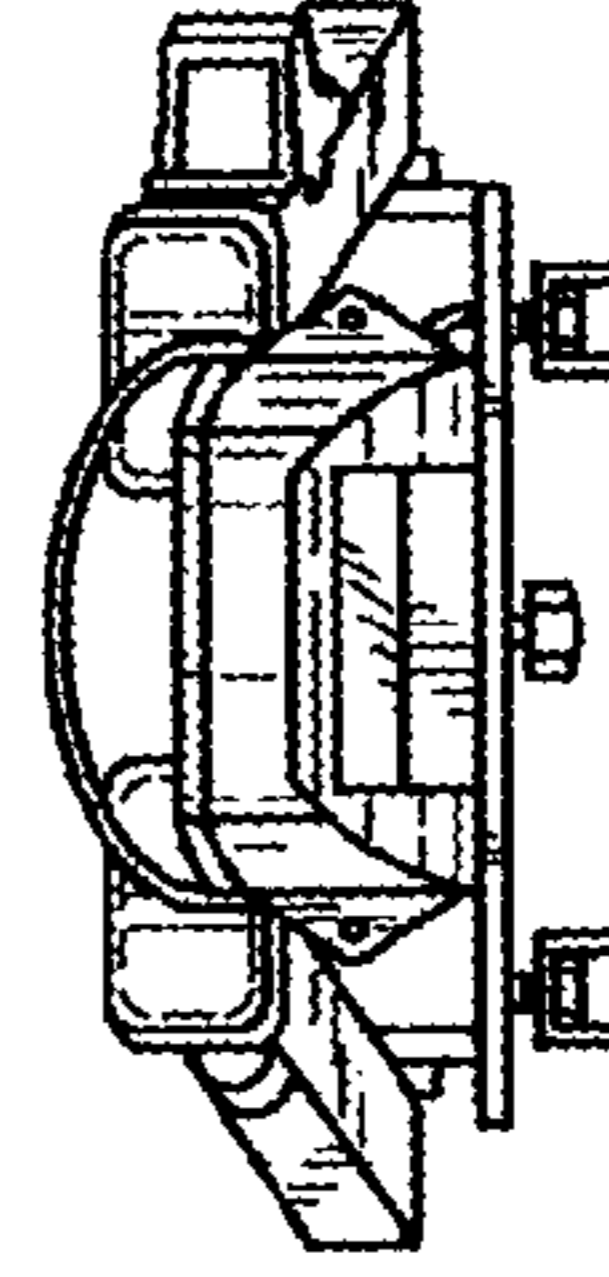

Fig. 12

Fig. 13

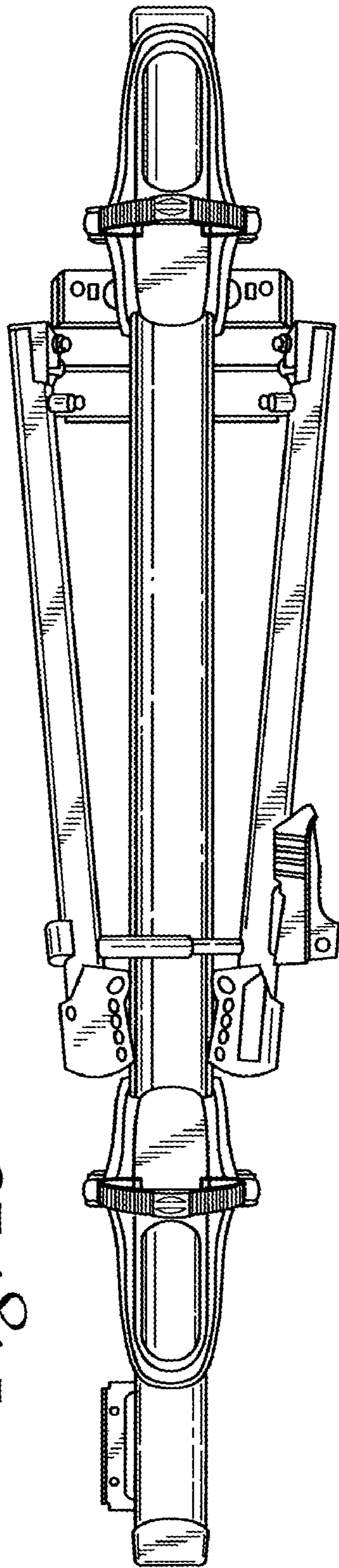

Fig. 14

