



US00D623096S

(12) **United States Design Patent**
Gower et al.

(10) **Patent No.:** **US D623,096 S**
(45) **Date of Patent:** **** Sep. 7, 2010**

(54) **BUGGY**

(75) Inventors: **Campbell Gower**, Wellington (NZ);
Philip Brace, Wellington (NZ)

(73) Assignee: **Phil and Teds Most Excellent Buggy Company Limited**, Wellington (NZ)

(**) Term: **14 Years**

(21) Appl. No.: **29/355,956**

(22) Filed: **Feb. 17, 2010**

Related U.S. Application Data

(63) Continuation of application No. 29/343,409, filed on Sep. 11, 2009, now abandoned.

(51) **LOC (9) Cl.** **12-12**

(52) **U.S. Cl.** **D12/129**

(58) **Field of Classification Search** D12/128-133;
D6/360, 367; 280/62, 647-650, 29, 200,
280/47.38, 250.1, 259, 642, 658; 297/DIG. 4;
296/65.03, 65.04; 224/409; D21/425, 426;
D34/17, 18

See application file for complete search history.

(56) **References Cited**

U.S. PATENT DOCUMENTS

D532,721 S * 11/2006 Wu et al. D12/129
7,377,537 B2 * 5/2008 Li 280/650
D583,719 S * 12/2008 Siewertsen D12/129
D587,635 S 3/2009 Gower et al.
D596,996 S * 7/2009 Yang D12/129
D599,257 S 9/2009 Gower et al.
D601,467 S * 10/2009 Karremans D12/129

FOREIGN PATENT DOCUMENTS

AU 319689 5/2008

OTHER PUBLICATIONS

Kiwi Explorer Buggy Instructions, Phil & Teds Most Excellent Buggy Company Limited, Wellington, NZ, Oct. 2000.

New Product Release, it's about freedom, Phil & Teds Most Excellent Buggy Company Limited, Wellington, NZ, 2004.

The twin, a side by side buggy that a lot less trouble, Phil & Teds Most Excellent Buggy Company Limited, Wellington, NZ, 2004.

(Continued)

Primary Examiner—Ian Simmons

Assistant Examiner—Charles D Hanson

(74) *Attorney, Agent, or Firm*—Dann, Dorfman, Herrell and Skillman, P.C.

(57) **CLAIM**

We claim the ornamental design for a buggy, as shown and described.

DESCRIPTION

FIG. 1 is a front left perspective view of a buggy embodying the design;

FIG. 2 is a front elevation view of the buggy;

FIG. 3 is a rear elevation view of the buggy;

FIG. 4 is a left side elevation view of the buggy;

FIG. 5 is a right side elevation view of the buggy;

FIG. 6 is a top plan view of the buggy; and,

FIG. 7 is an additional front left perspective view of the buggy.

Features shown with broken lines form no part of the design to be patented.

The design is embodied in a buggy for transporting a small child.

1 Claim, 7 Drawing Sheets

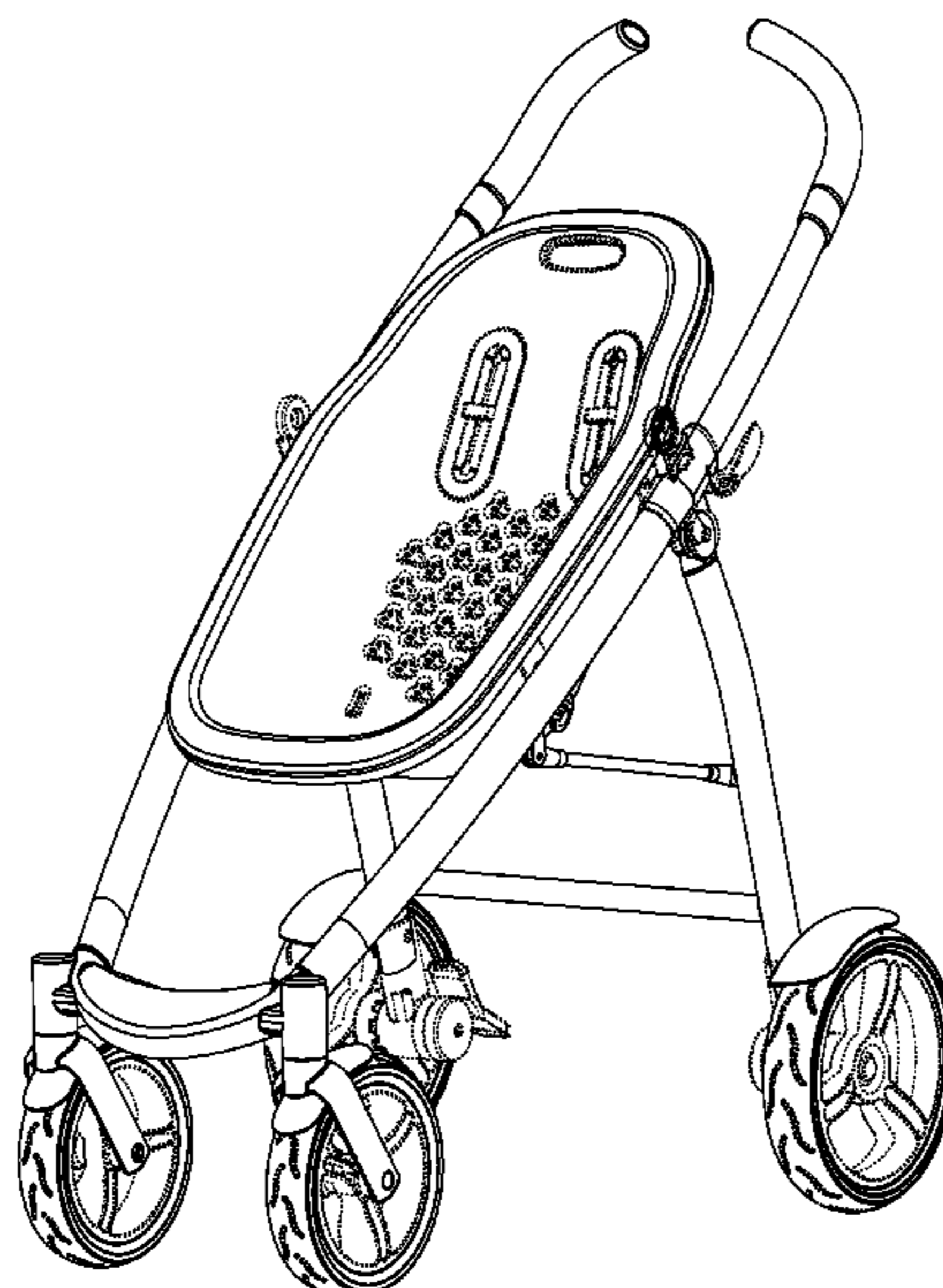

OTHER PUBLICATIONS

Kiwi Explorer Buggy, 5 Reasons, Phil & Teds Most Excellent Buggy Company Limited, Wellington, NZ, 2000.

The buggy that changes with your family's needs, Phil & Teds Most Excellent Buggy Company Limited, Wellington, NZ, 2004.

Inline double sport, Phil & Teds Most Excellent Buggy Company, Wellington, NZ, Mar. 2007.

Phil & Teds Most Excellent Buggy Company Limited buggy disclosed Sep. 2008.

U.S. Appl. No. 29/284,718, filed Sep. 13, 2007, Gower et al.

* cited by examiner

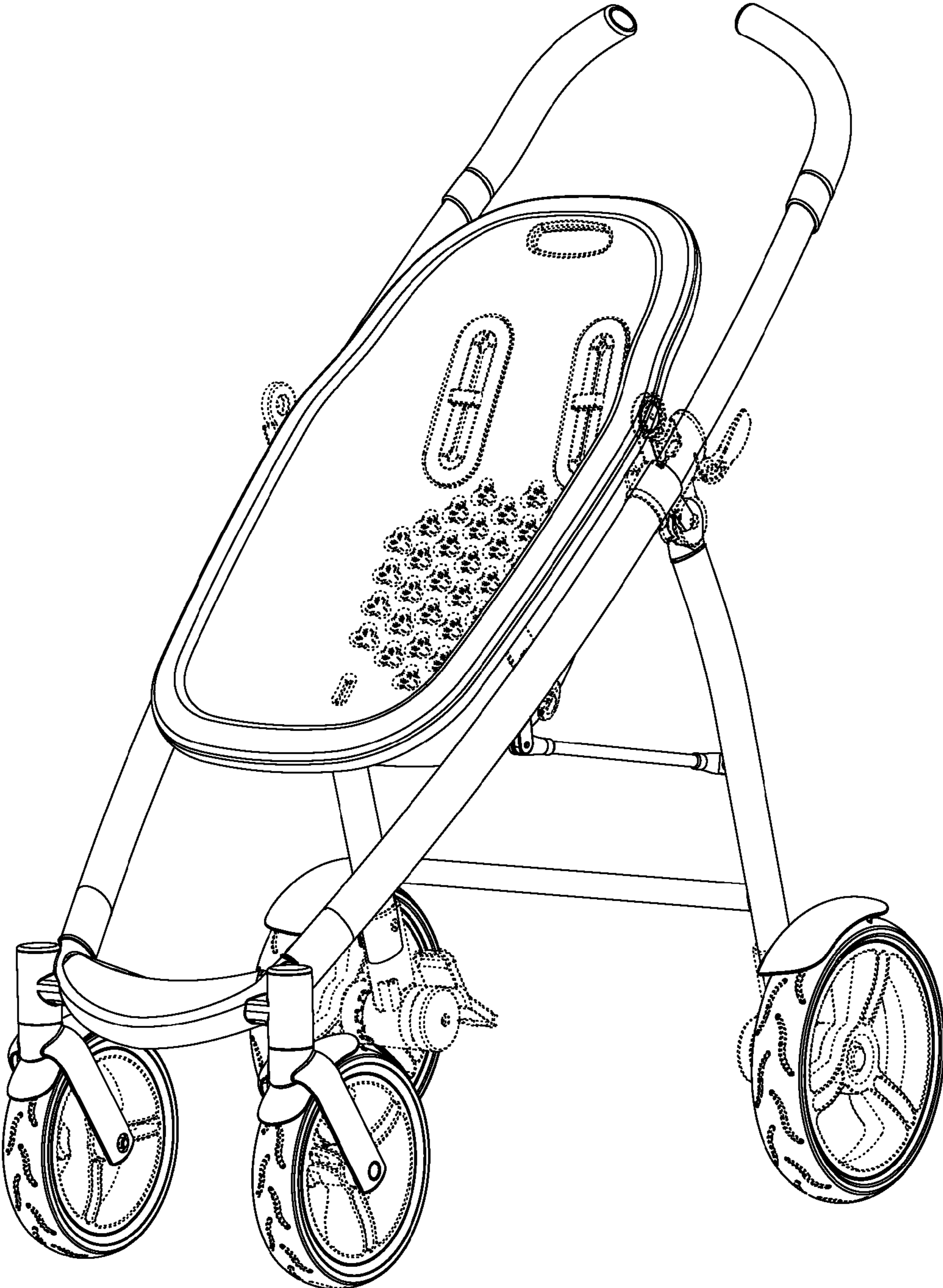

Figure 1

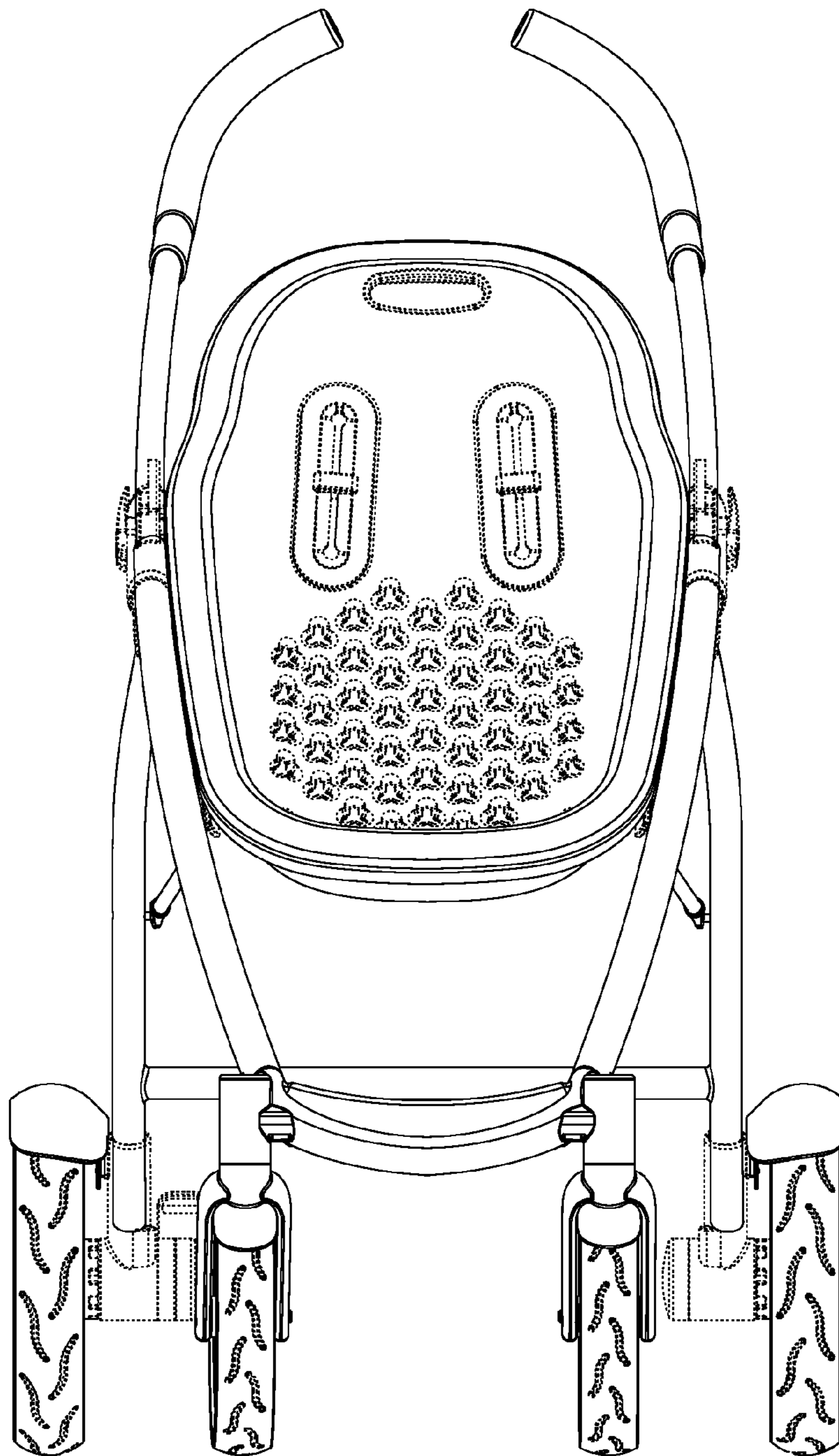

Figure 2

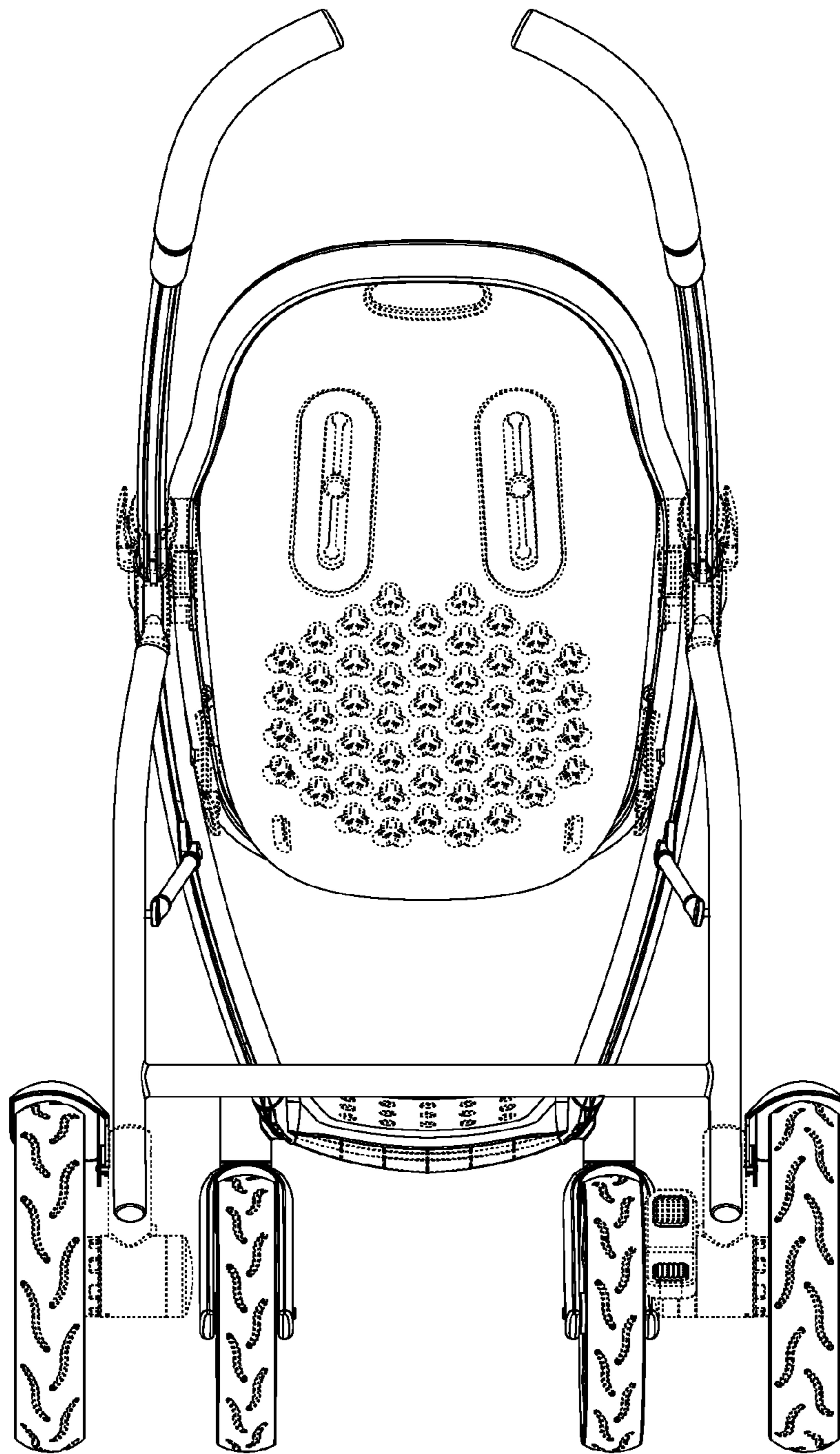

Figure 3

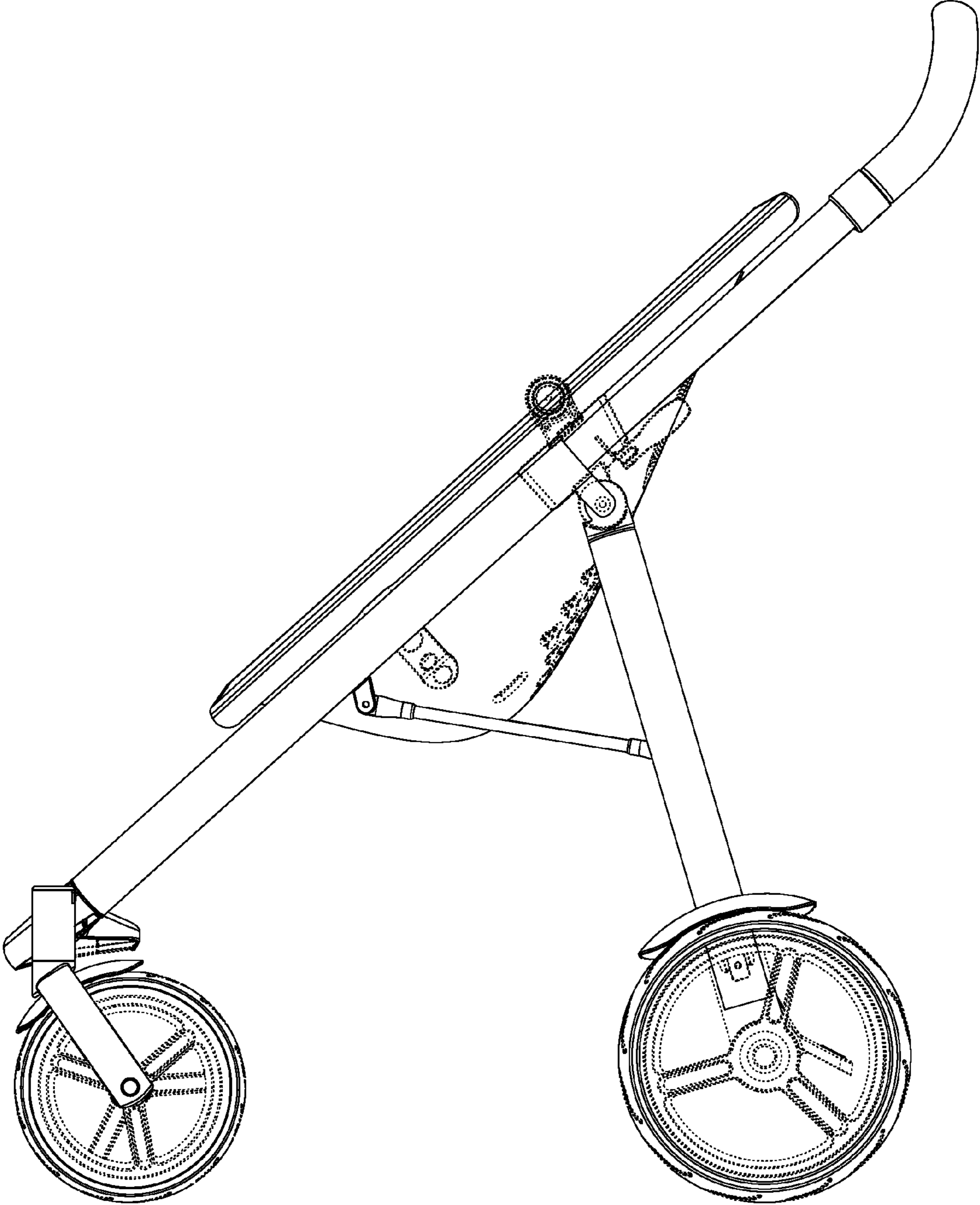

Figure 4

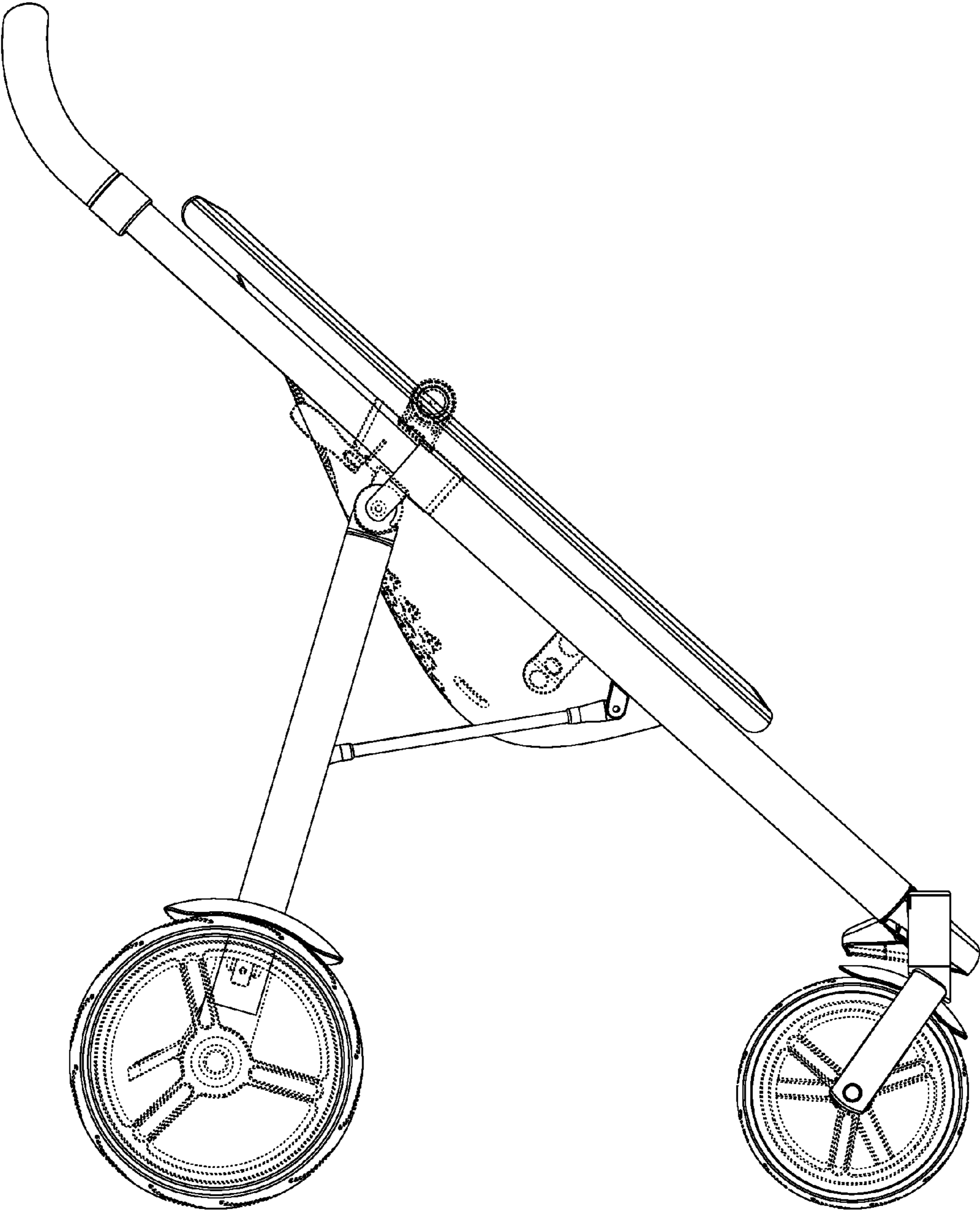

Figure 5

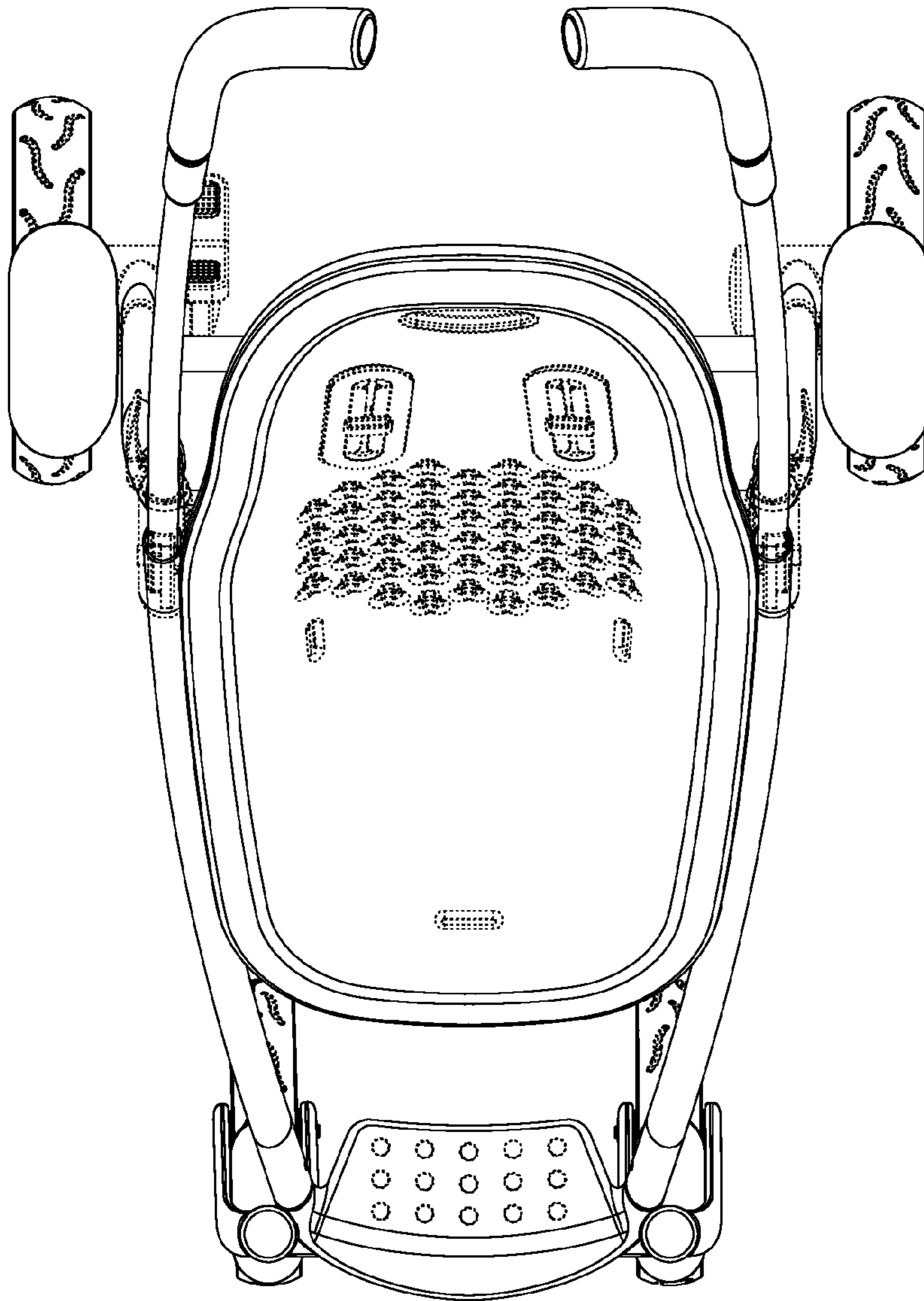

Figure 6

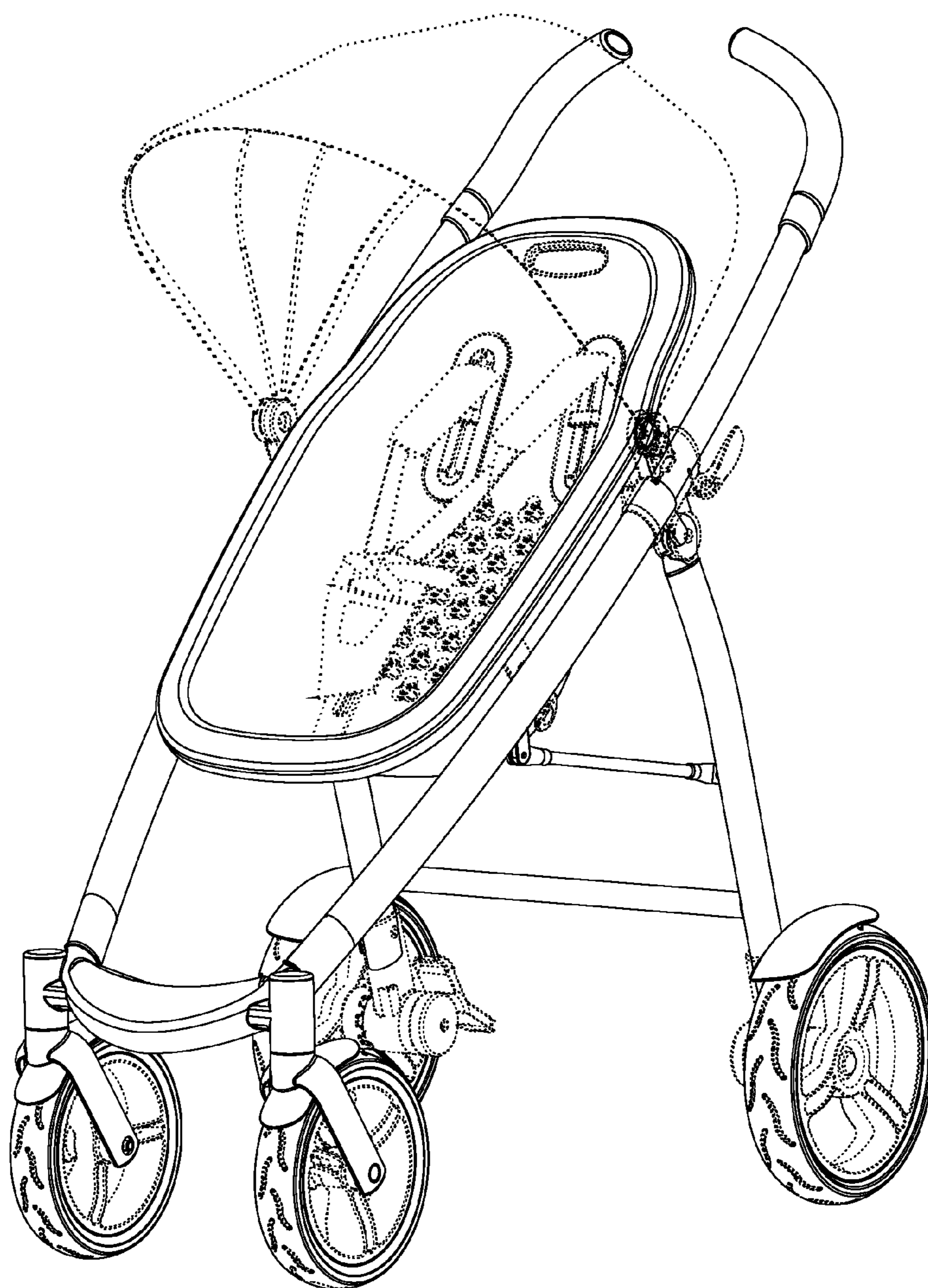

Figure 7