



US00D623057S

(12) **United States Design Patent**
Kletz

(10) **Patent No.:** **US D623,057 S**

(45) **Date of Patent:** **** Sep. 7, 2010**

(54) **PACKAGING FOR PAPER PRODUCT**

(75) Inventor: **Amy Marie Kletz**, Cincinnati, OH (US)

(73) Assignee: **The Procter & Gamble Company**,
Cincinnati, OH (US)

(**) Term: **14 Years**

(21) Appl. No.: **29/346,751**

(22) Filed: **Nov. 5, 2009**

(51) **LOC (9) Cl.** **09-01**

(52) **U.S. Cl.** **D9/434; D9/600**

(58) **Field of Classification Search** D9/600,
D9/652, 667, 516, 434; D14/489-493; D20/11;
206/457, 527; 215/379, 400; 220/890
See application file for complete search history.

(56) **References Cited**

U.S. PATENT DOCUMENTS

D391,949 S * 3/1998 Munson D14/493
D422,583 S * 4/2000 Herceg et al. D14/493
D535,661 S * 1/2007 Gusmorino et al. D14/492

D555,663 S * 11/2007 Nagata et al. D14/493
D563,424 S * 3/2008 Gusmorino et al. D14/492
D576,483 S * 9/2008 Wintmolders et al. D9/418

* cited by examiner

Primary Examiner—Sandra Morris

(74) *Attorney, Agent, or Firm*—Betty J. Zea

(57) **CLAIM**

The ornamental design for a packaging for paper product, as shown and described.

DESCRIPTION

FIG. 1 is a front view of packaging for paper product that has the design; and,

FIG. 2 is a perspective view of a paper product that is wrapped in the packaging seen in FIG. 1.

The broken lines immediately adjacent the solid line areas represent the bounds of the claimed design while all other broken lines are directed to environment and are for illustrative purposes only; the broken lines form no part of the claimed design.

1 Claim, 1 Drawing Sheet

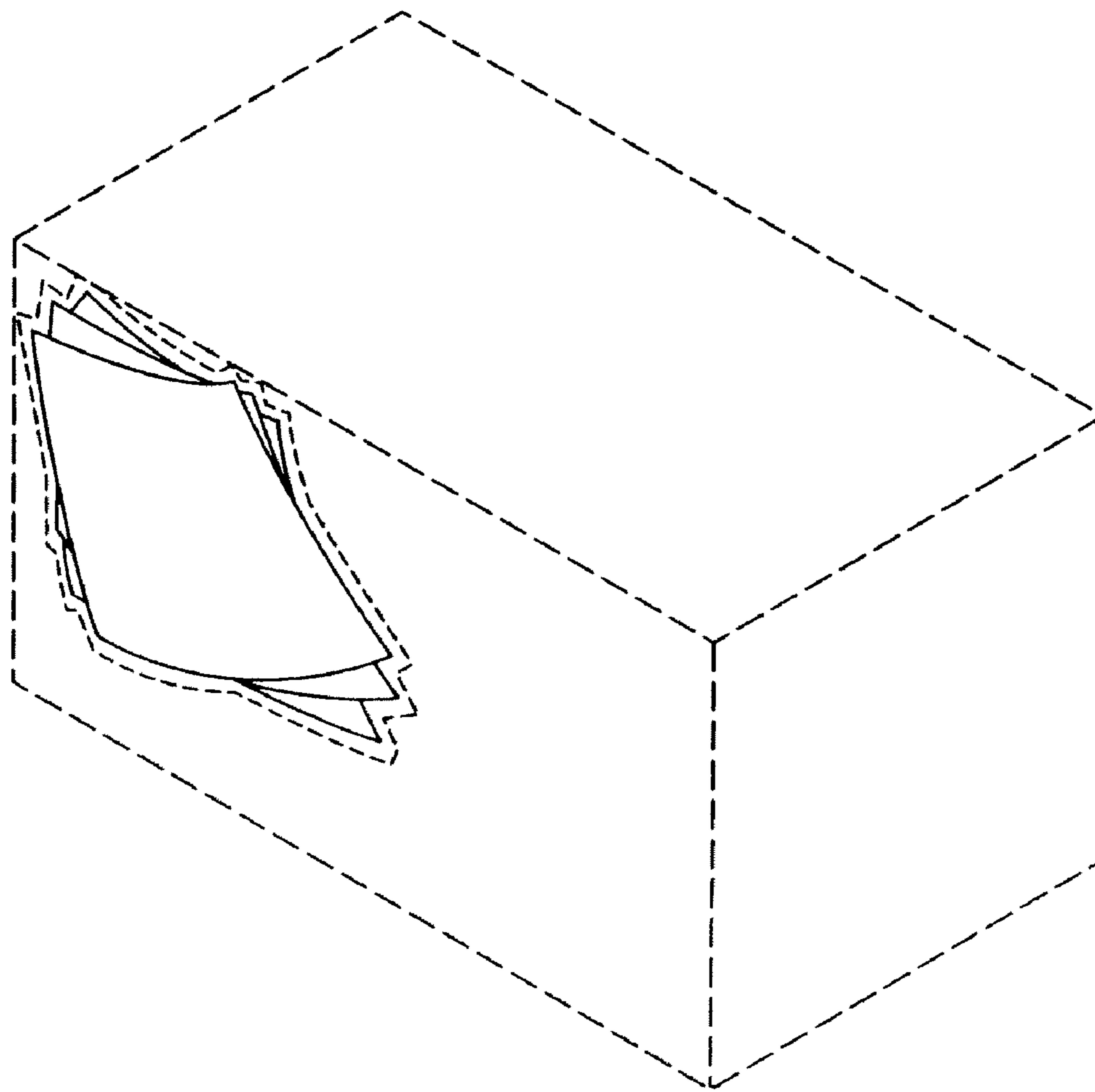

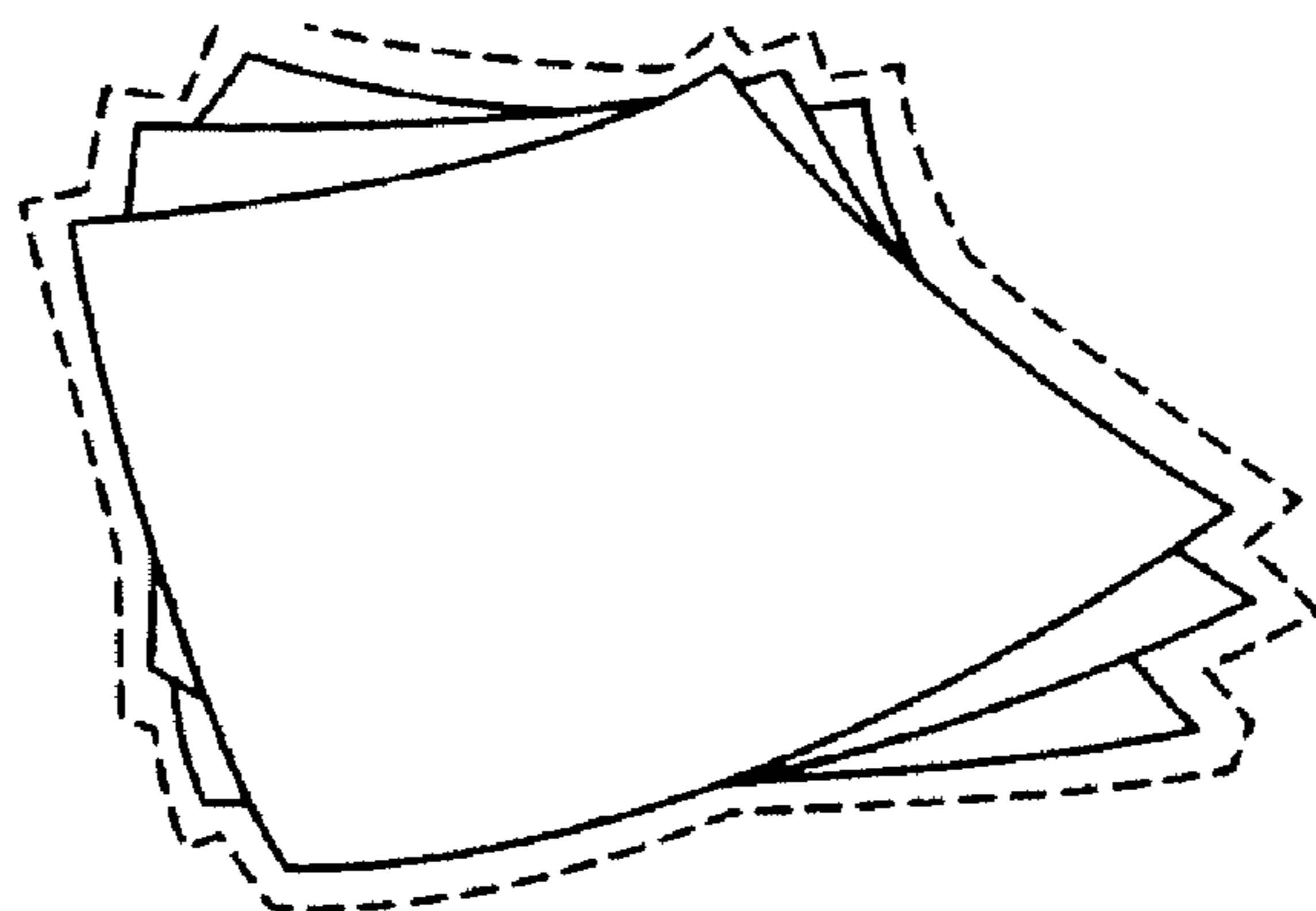

FIG. 1

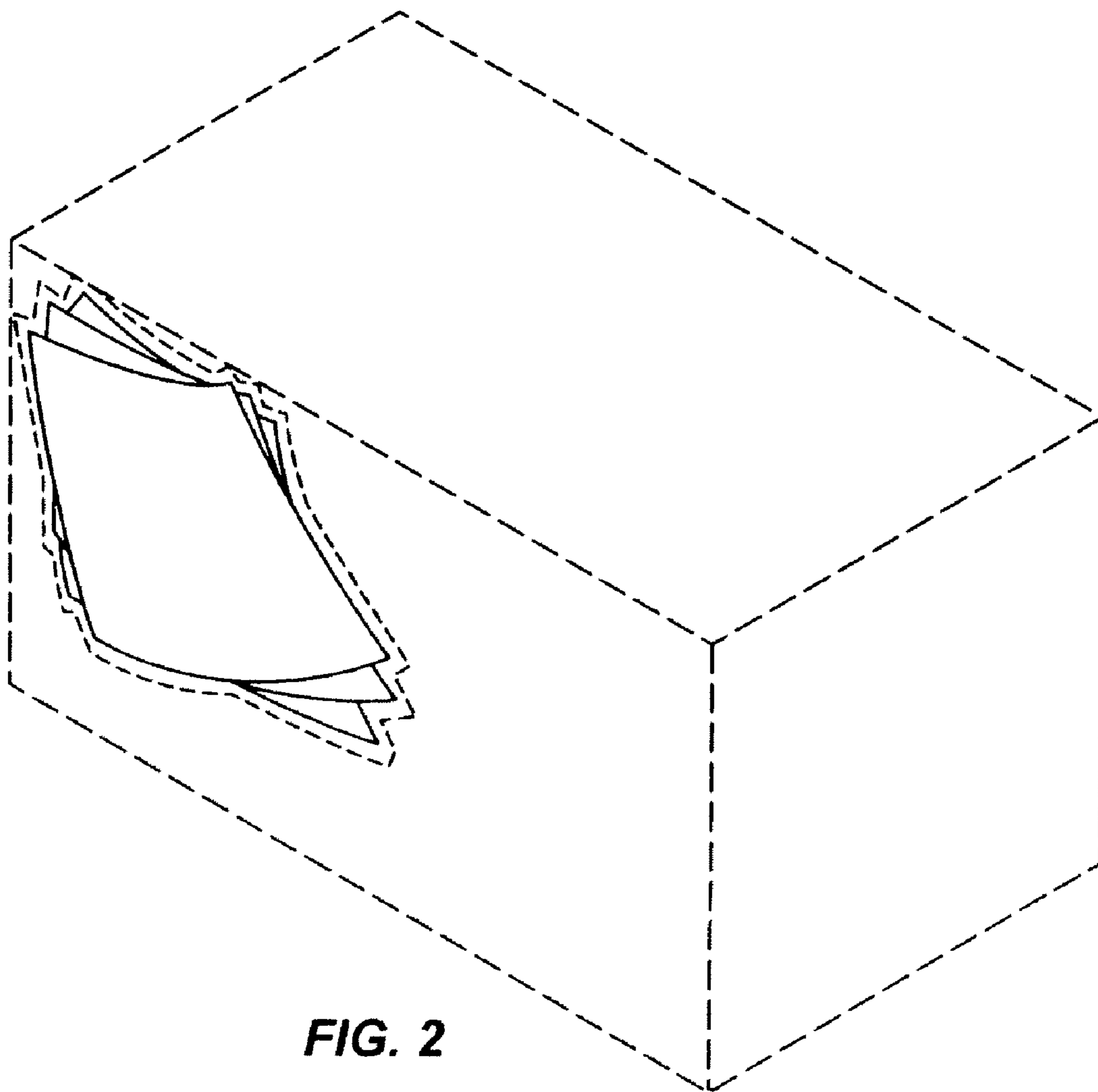

FIG. 2