



US00D622988S

(12) **United States Design Patent**  
**Alford**

(10) **Patent No.:** **US D622,988 S**

(45) **Date of Patent:** **\*\* Sep. 7, 2010**

(54) **SEAT CONTROL INTERFACE**

(75) Inventor: **Daniel Alford**, Statesville, NC (US)

(73) Assignee: **BE Aerospace, Inc.**, Wellington, FL (US)

(\*\*) Term: **14 Years**

(21) Appl. No.: **29/329,202**

(22) Filed: **Dec. 10, 2008**

(51) **LOC (9) Cl.** ..... **06-01**

(52) **U.S. Cl.** ..... **D6/501**

(58) **Field of Classification Search** ..... D6/334-336,  
D6/360-369, 374, 379-380, 498, 500-502;  
D10/108; D13/162-168; D21/324; 200/1 R,  
200/5 A, 5 R, 6 A, 52 R, 310, 315, 512; 296/153;  
297/411.12; 307/10.1; 362/29, 85, 464,  
362/802

See application file for complete search history.

(56) **References Cited**

**U.S. PATENT DOCUMENTS**

D321,215 S *	10/1991	Shamis	.....	D21/324
D338,191 S *	8/1993	Ahmed et al.	.....	D13/162
D457,862 S *	5/2002	Falk et al.	.....	D13/162
D458,230 S *	6/2002	Hand et al.	.....	D13/164
6,608,399 B2 *	8/2003	McConnell et al.	.....	307/10.1
7,002,089 B2 *	2/2006	Stevenson	.....	200/512
D554,077 S *	10/2007	Laurent et al.	.....	D13/164
D554,078 S *	10/2007	Laurent et al.	.....	D13/164

D589,829 S *	4/2009	Friedli	.....	D10/108
D595,667 S *	7/2009	Lasky et al.	.....	D13/168
D611,003 S *	3/2010	Muirhead et al.	.....	D13/162
2003/0052514 A1 *	3/2003	Schmidt et al.	.....	296/153
2004/0140183 A1 *	7/2004	Yen	.....	200/5 A

\* cited by examiner

*Primary Examiner*—Caron Veynar

*Assistant Examiner*—Ricky Pham

(74) *Attorney, Agent, or Firm*—Adams Intellectual Property Law

(57) **CLAIM**

I claim the ornamental design for a seat control interface, as shown and described.

**DESCRIPTION**

FIG. 1 is a perspective view of the seat control interface according to the invention;

FIG. 2 is an enlarged perspective view of the seat control interface according to the invention;

FIG. 3 is an enlarged side elevational view of the seat control interface according to the invention;

FIG. 4 is a front elevational view of the seat control interface according to the invention; and,

FIG. 5 is a top plan view of the seat control interface according to the invention.

The broken lines shown in the drawings are for illustrative purposes only and form no part of the claimed design.

**1 Claim, 3 Drawing Sheets**

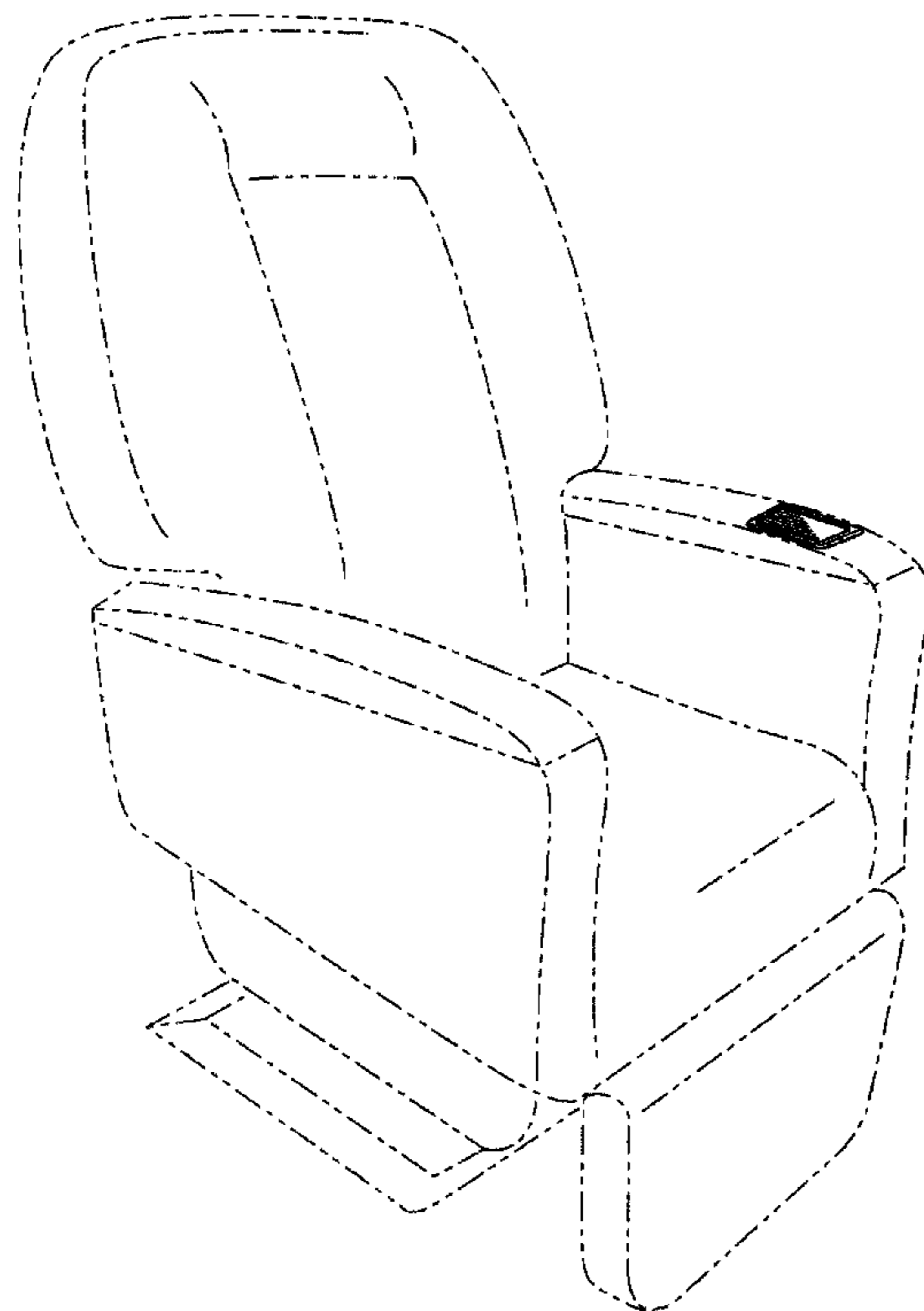

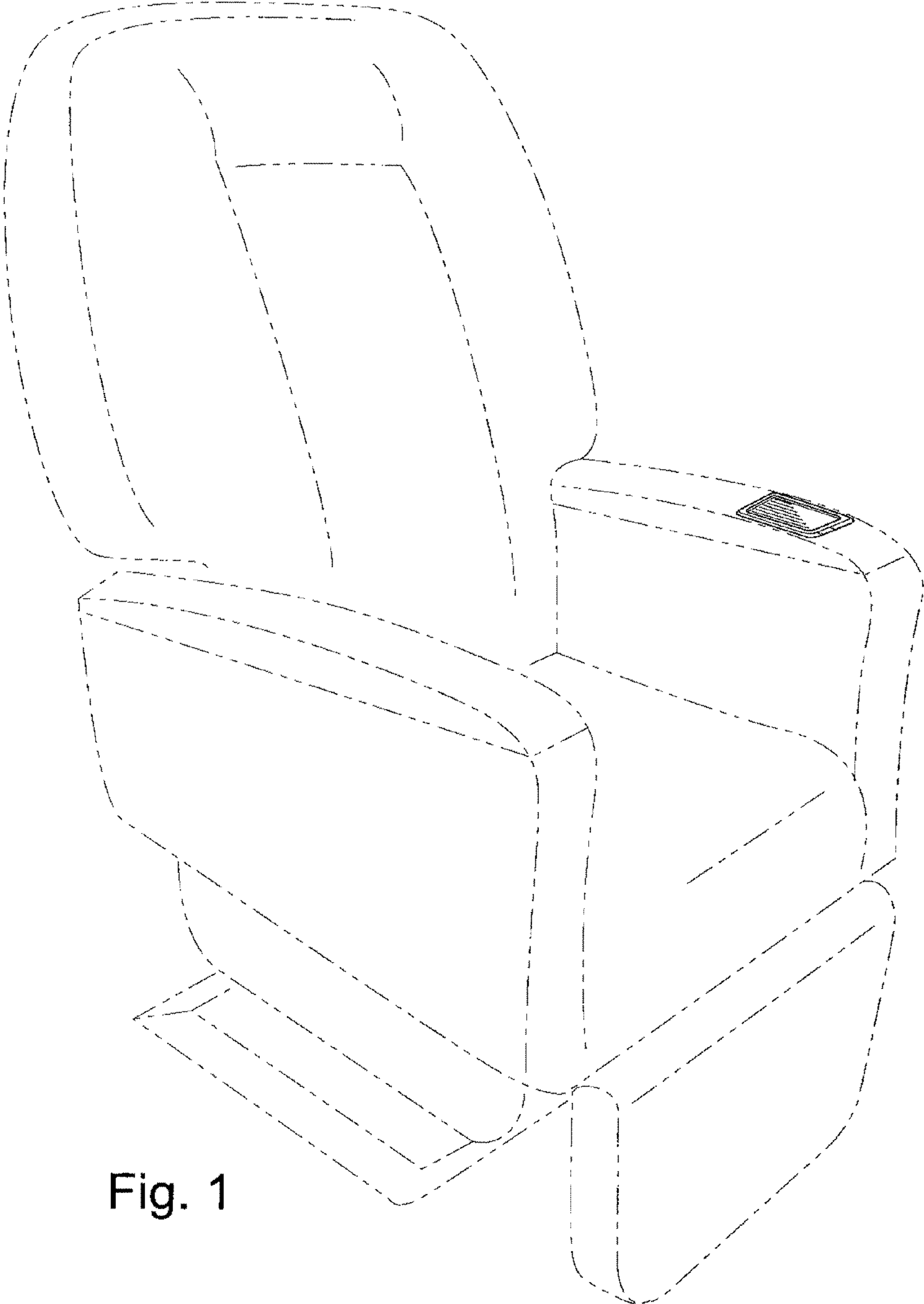

Fig. 1

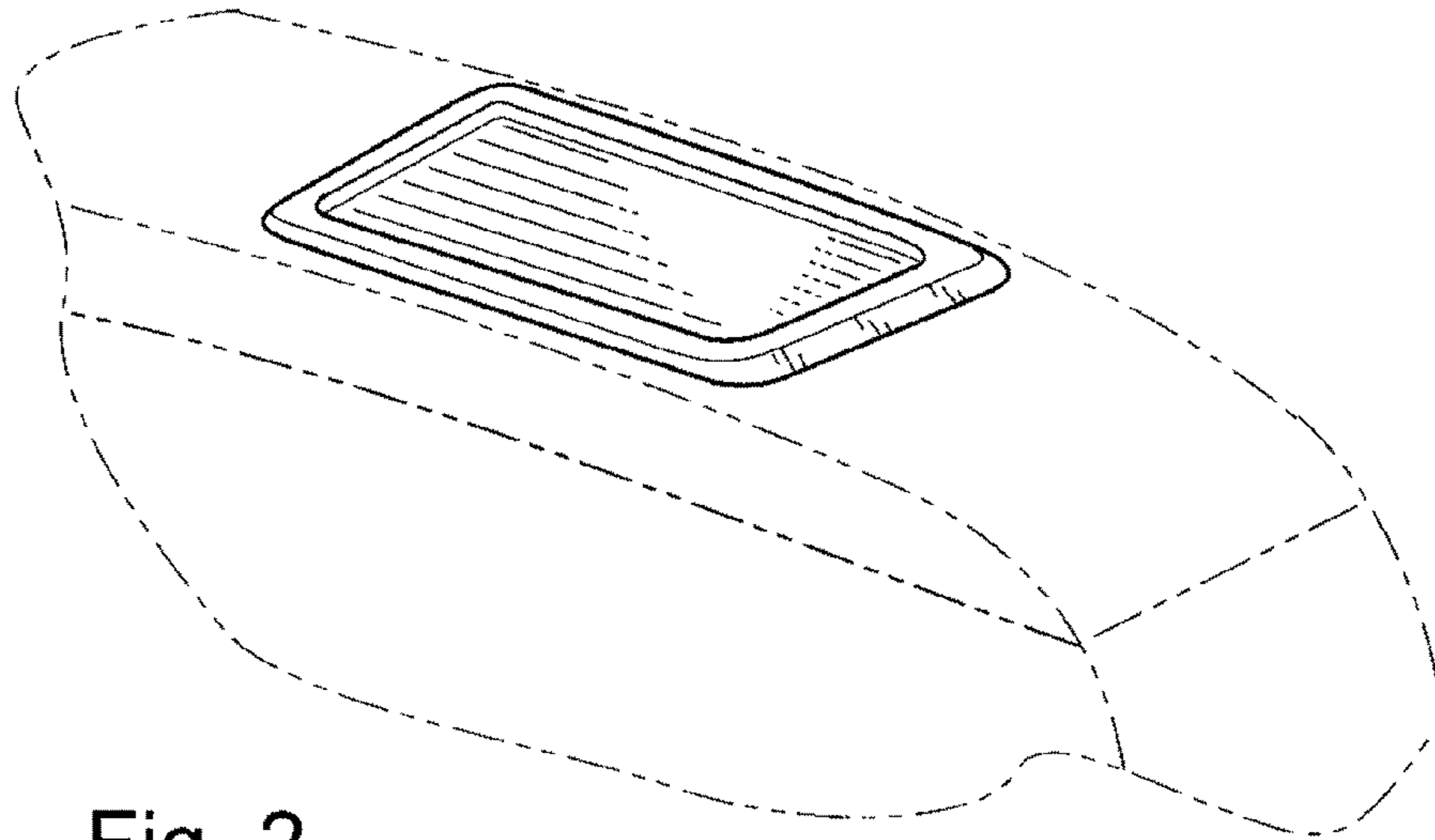

Fig. 2

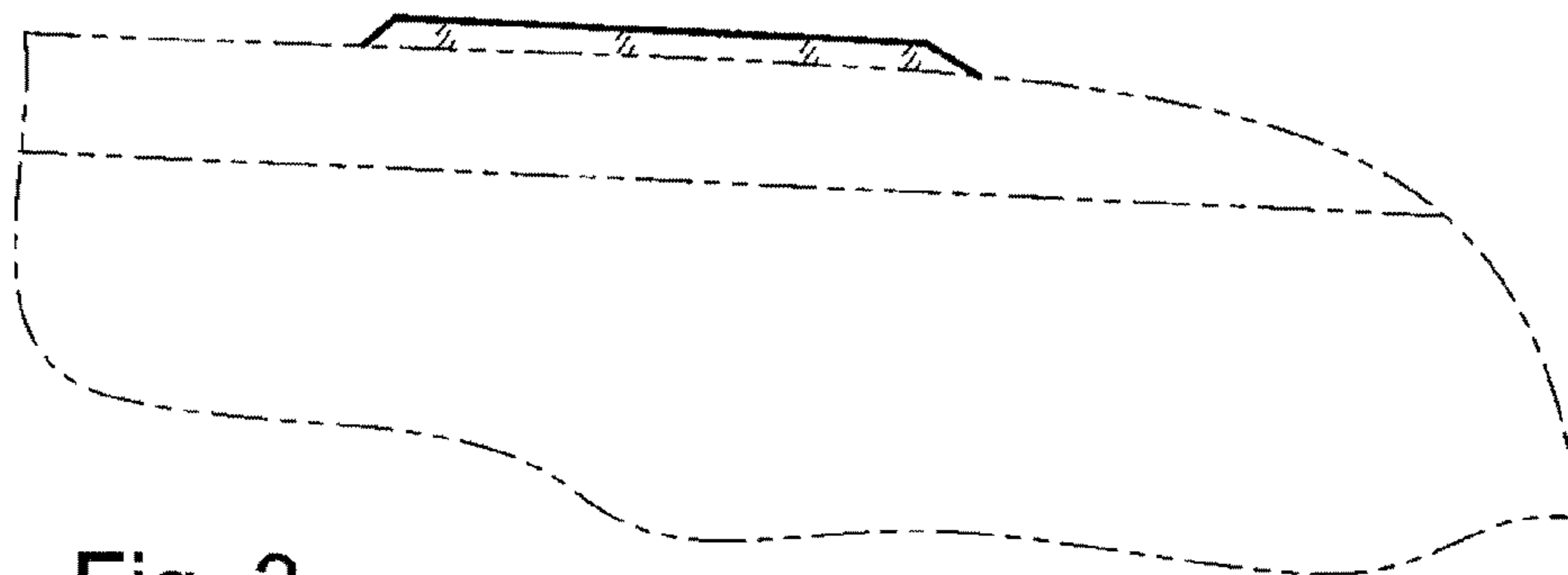

Fig. 3

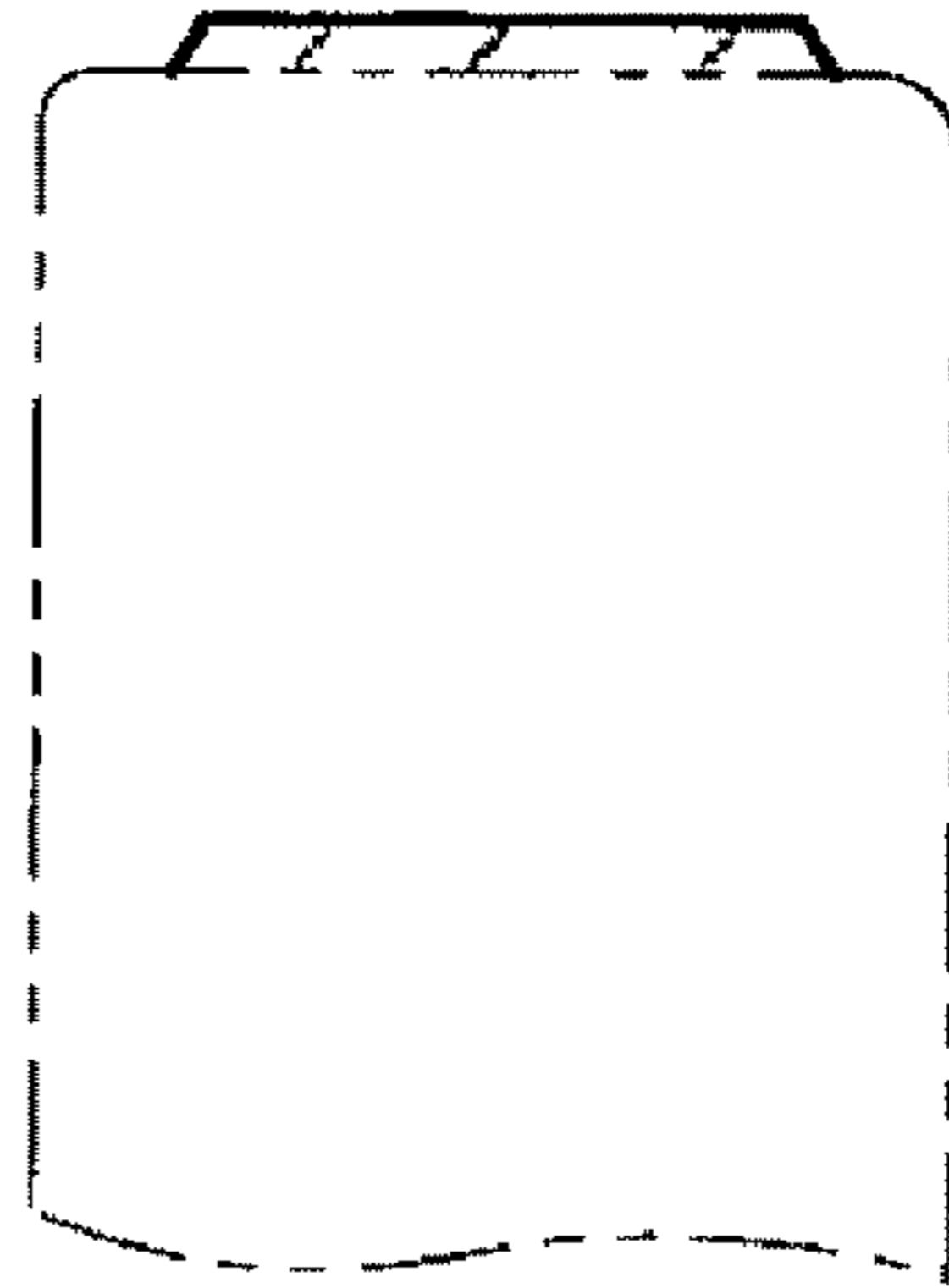

Fig. 4

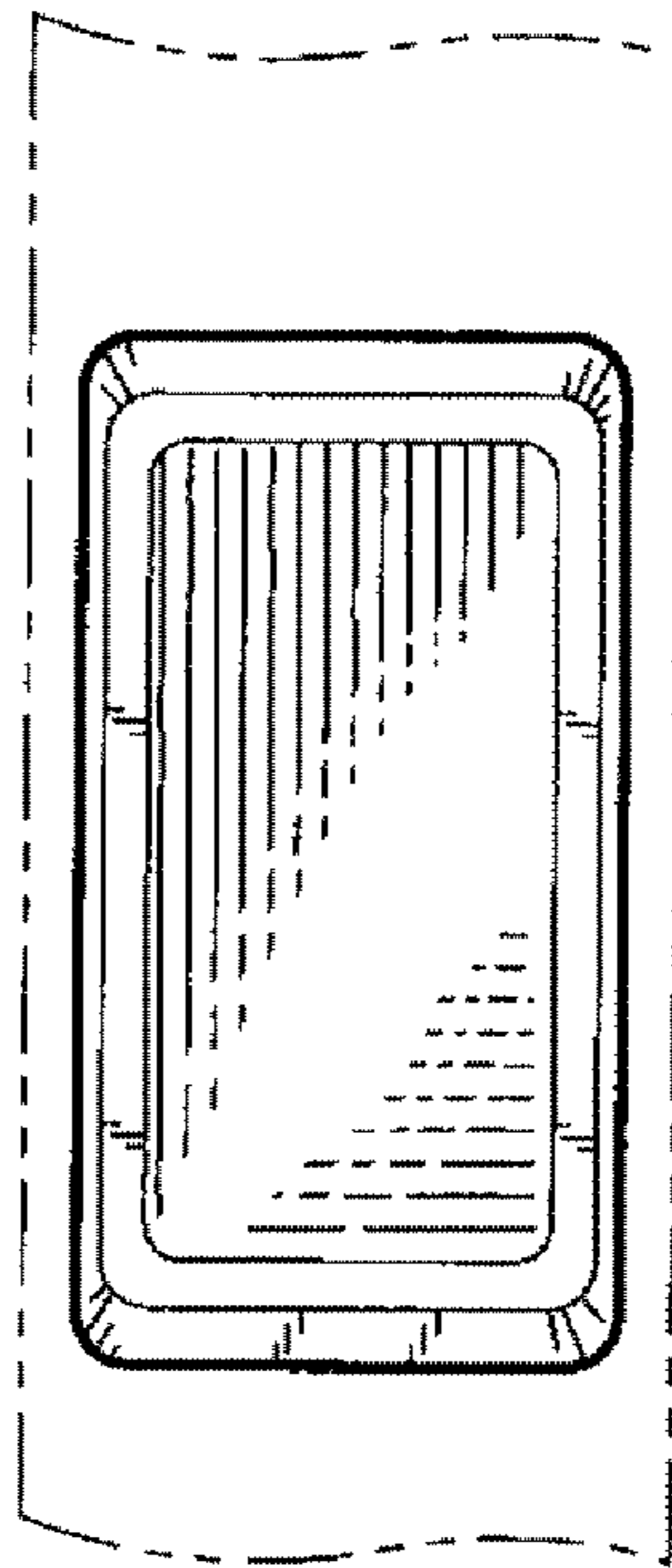

Fig. 5