



US00D622767S

(12) **United States Design Patent**
Liu

(10) **Patent No.:** **US D622,767 S**

(45) **Date of Patent:** **** Aug. 31, 2010**

(54) **HIGHLIGHTER**

(75) Inventor: **Luosen Liu**, Ningbo (CN)

(73) Assignee: **Beifa Group Co., Ltd.**, Ningbo (CN)

(**) Term: **14 Years**

(21) Appl. No.: **29/338,876**

(22) Filed: **Jun. 19, 2009**

(30) **Foreign Application Priority Data**

Dec. 19, 2008 (CN) 2008 3 0346478

(51) **LOC (9) Cl.** **19-06**

(52) **U.S. Cl.** **D19/43**

(58) **Field of Classification Search** D19/35,
D19/36, 41-51, 53-57; 24/11 R, 11 F, 11 P;
401/52, 99, 100, 104-109, 192, 195, 196
See application file for complete search history.

(56) **References Cited**

U.S. PATENT DOCUMENTS

2,983,946	A *	5/1961	Edelstone et al.	401/4
D205,330	S	7/1966	Capezzuto	
D286,546	S	11/1986	Funahashi	
D302,175	S *	7/1989	Ohashi et al.	D19/43
D311,550	S *	10/1990	Yazaki	D19/43
D313,245	S *	12/1990	Iwase	D19/43
D326,684	S *	6/1992	Shike et al.	D19/49
D355,442	S *	2/1995	Chuang	D19/43
D369,183	S	4/1996	Yoshida	
D389,862	S *	1/1998	Imagawa	D19/43
D448,407	S	9/2001	Huang	
D471,234	S	3/2003	Okutani	

D535,330	S	1/2007	Hung	
D546,388	S *	7/2007	Hung	D19/43
D575,336	S	8/2008	Qiu	
D601,191	S *	9/2009	Hung	D19/36
D601,194	S *	9/2009	Hung	D19/43
D601,627	S *	10/2009	Liu	D19/51
D602,086	S *	10/2009	Liu	D19/49
D605,697	S	12/2009	Liu	
D608,827	S *	1/2010	Hung	D19/49
D610,195	S *	2/2010	Liu	D19/41

* cited by examiner

Primary Examiner—Elizabeth A Albert

(74) *Attorney, Agent, or Firm*—Christensen O'Connor Johnson Kindness PLLC

(57) **CLAIM**

The ornamental design for a highlighter, as shown and described.

DESCRIPTION

FIG. 1 is an upper rear left perspective view of a highlighter showing my new design;

FIG. 2 is a right side elevation view thereof;

FIG. 3 is an enlarged top plan view thereof;

FIG. 4 is a front perspective view thereof;

FIG. 5 is a left side elevation view thereof;

FIG. 6 is a bottom plan view thereof; and,

FIG. 7 is a rear elevation view thereof.

The broken lines showing portions of the top are included for the purpose of illustrating environment and form no part of the claimed design.

1 Claim, 3 Drawing Sheets

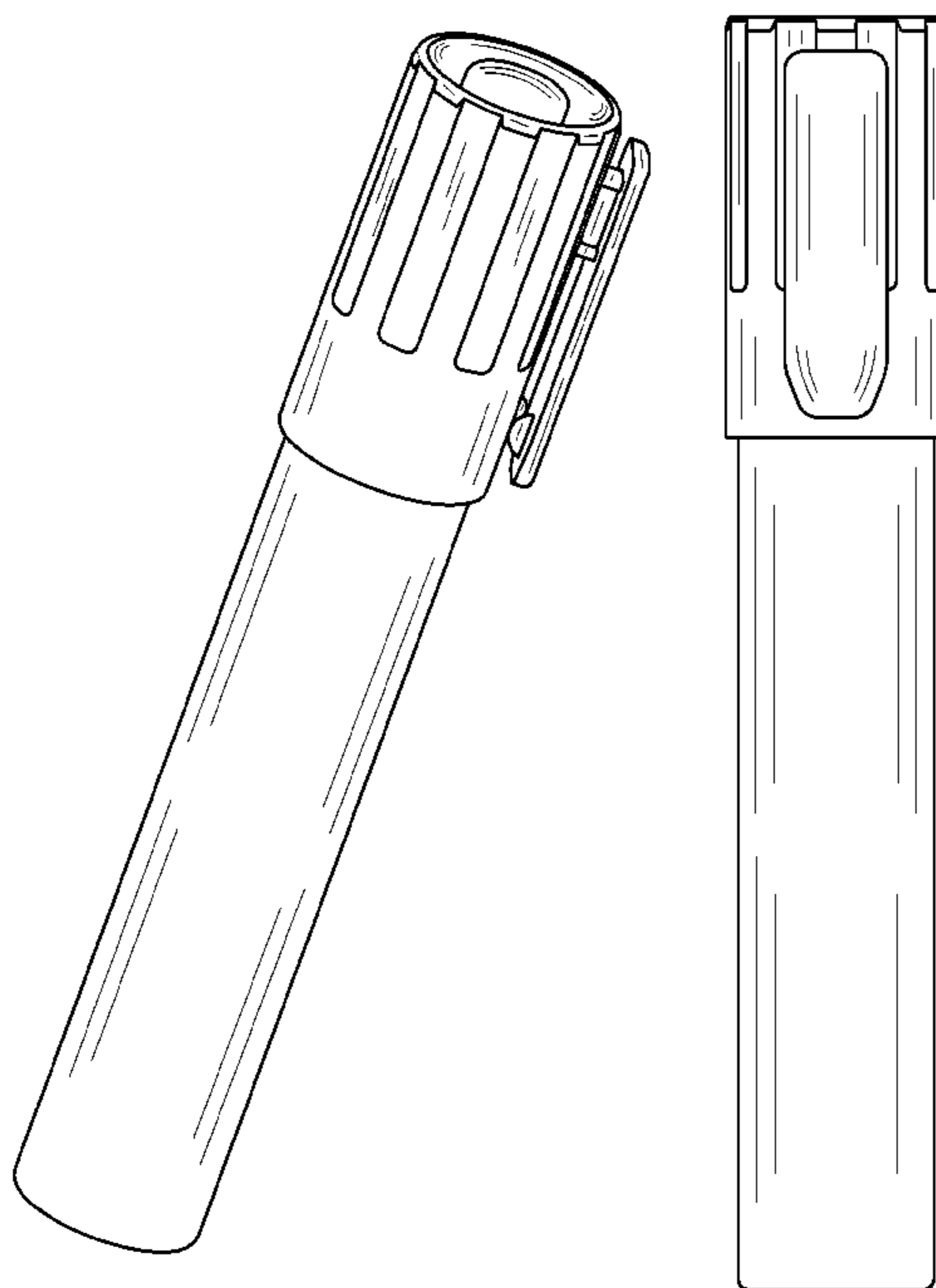

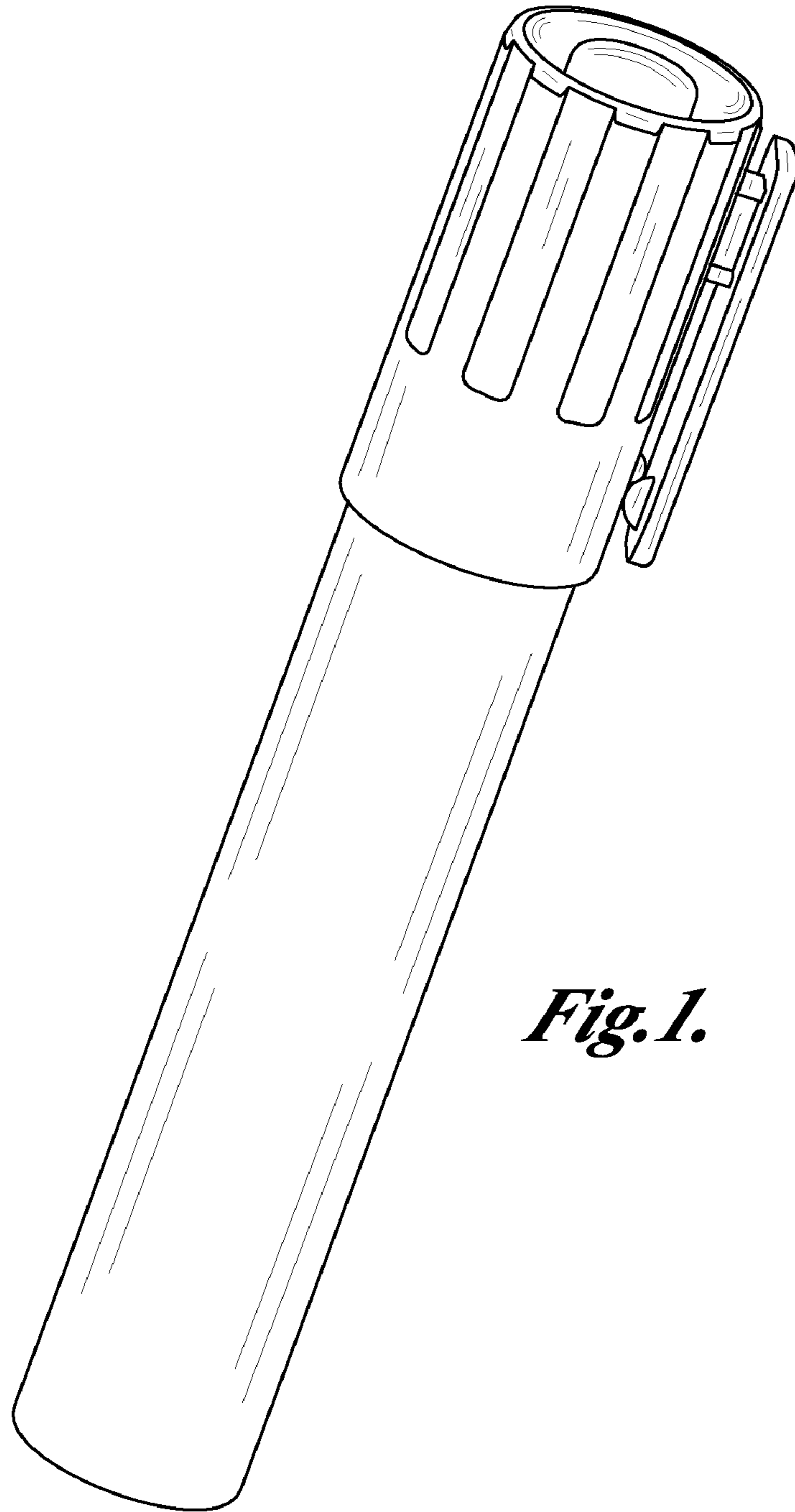

Fig. 1.

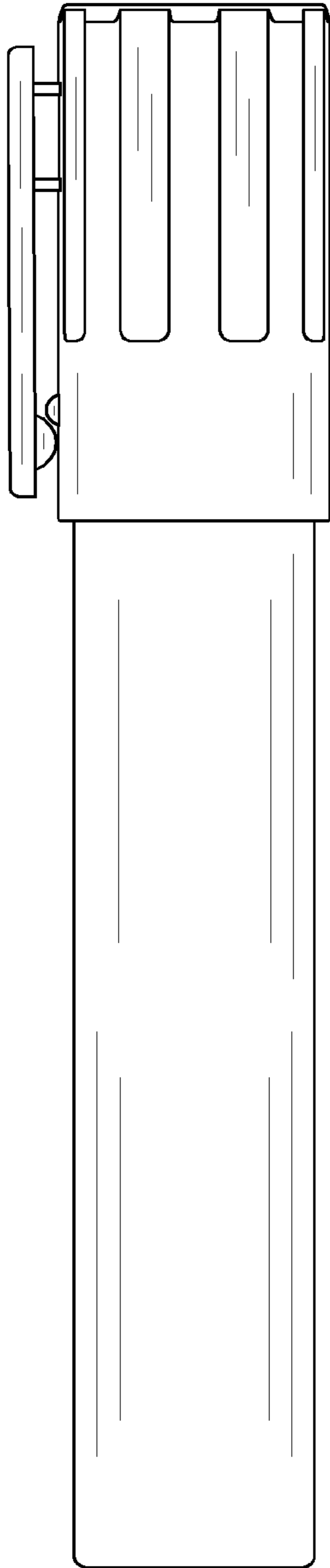

Fig. 2.

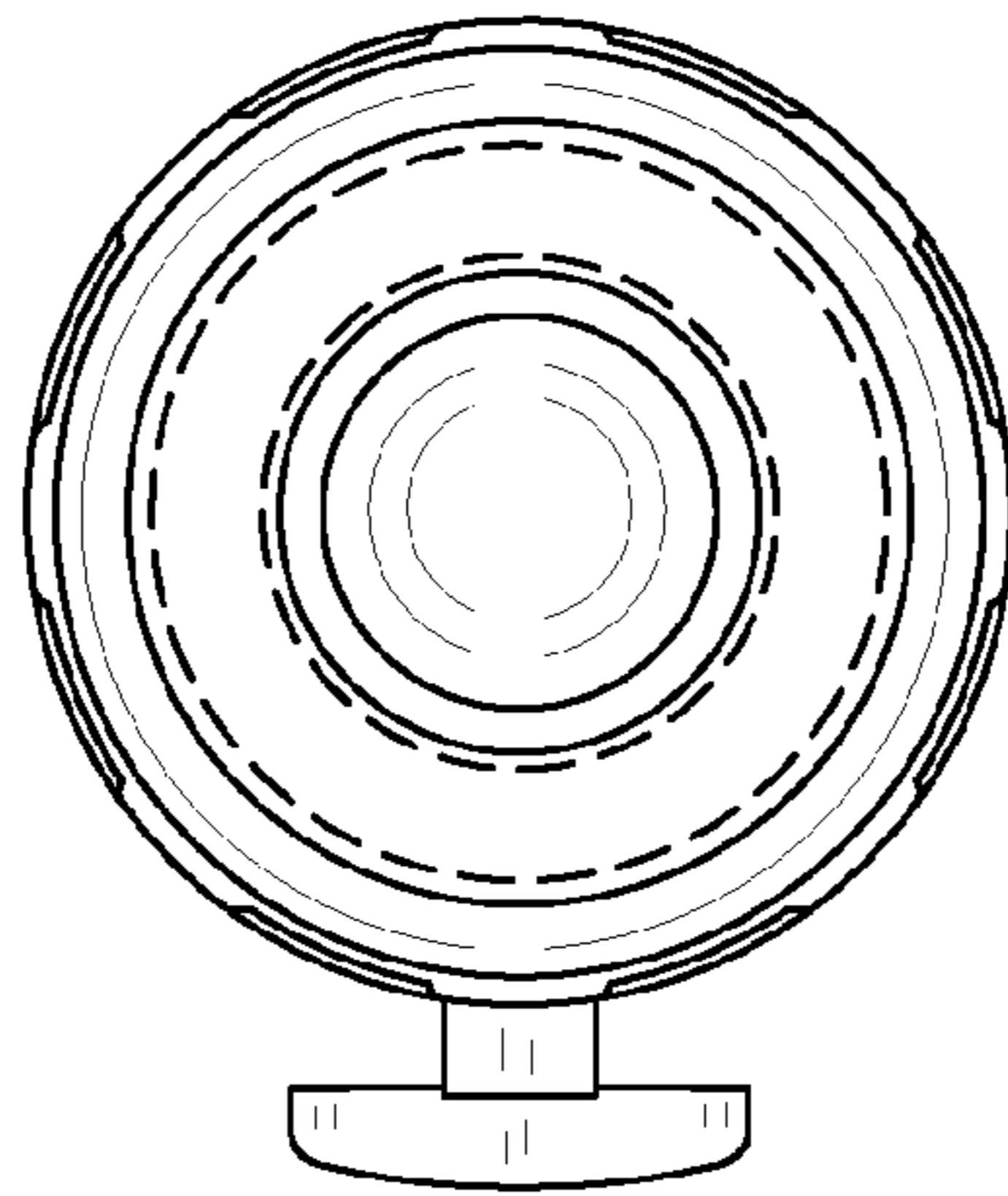

Fig. 3.

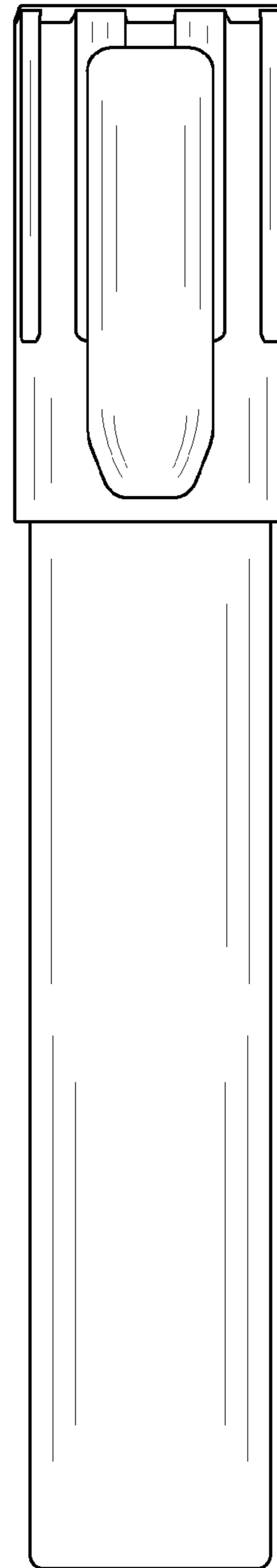

Fig. 4.

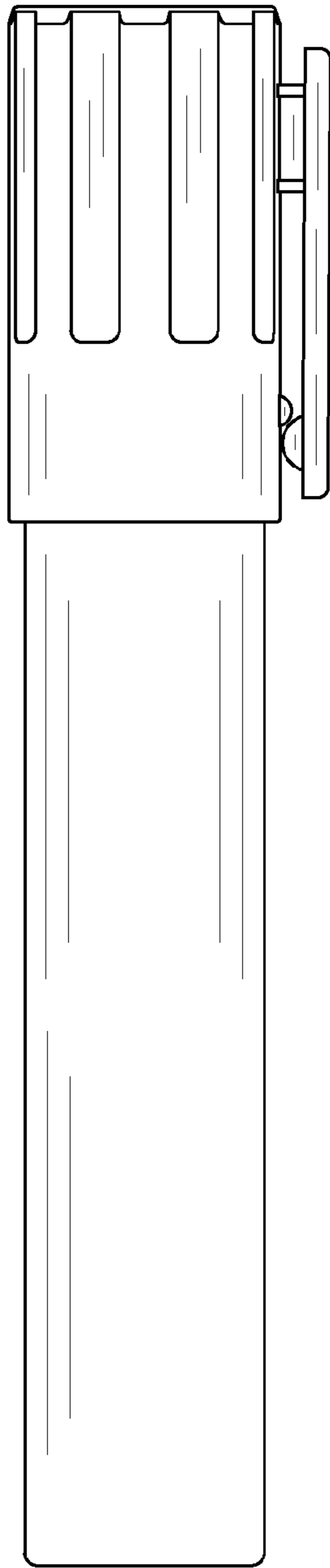

Fig. 5.

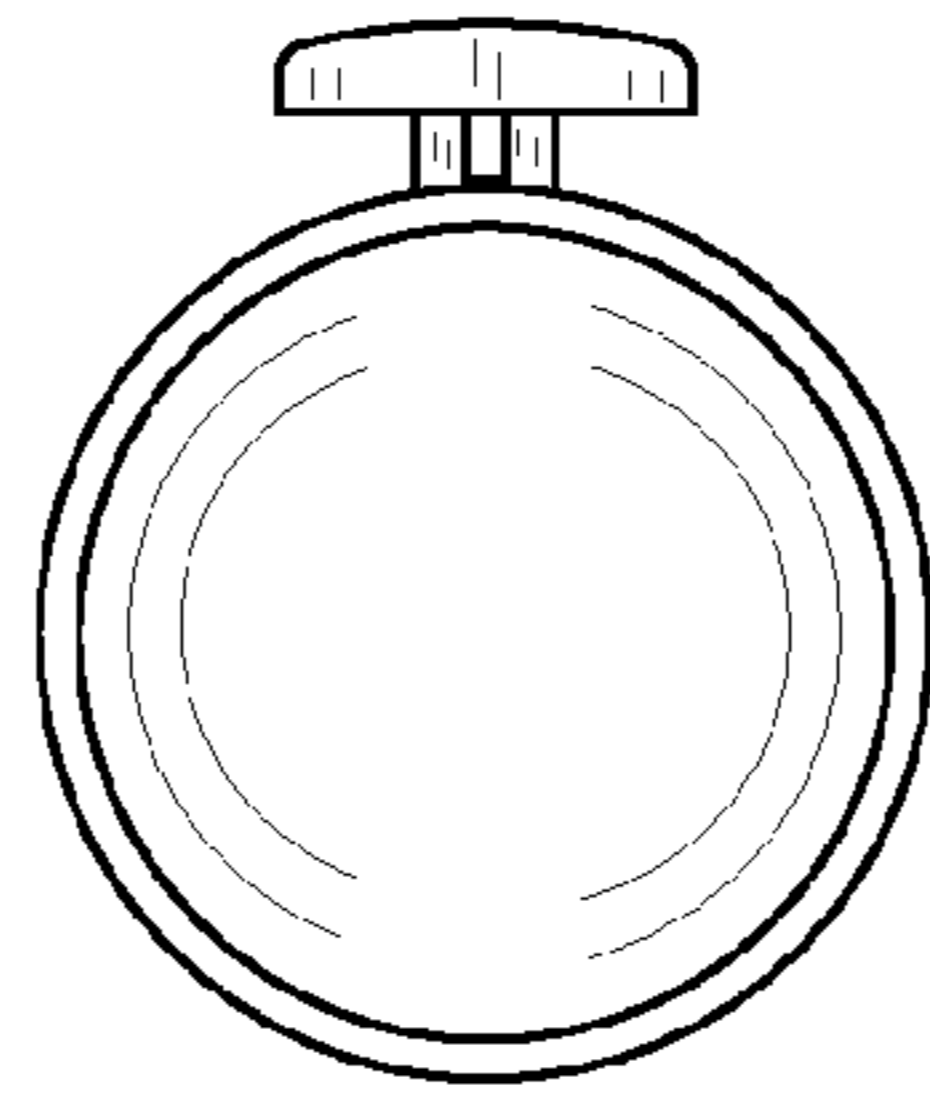

Fig. 6.

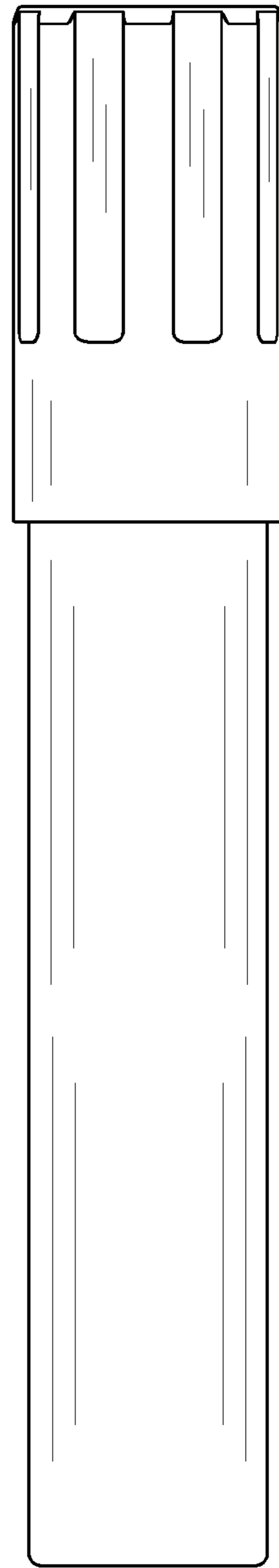

Fig. 7.