



US00D622653S

(12) **United States Design Patent**
Moore et al.

(10) **Patent No.:** **US D622,653 S**

(45) **Date of Patent:** **** Aug. 31, 2010**

(54) **AIRCRAFT**

(75) Inventors: **Matthew D. Moore**, Everett, WA (US);
Kelly L. Boren, Arlington, WA (US);
Edward C. Marques, Issaquah, WA
(US)

(73) Assignee: **The Boeing Company**, Irvine, CA (US)

(**) Term: **14 Years**

(21) Appl. No.: **29/247,058**

(22) Filed: **May 26, 2006**

Related U.S. Application Data

(63) Continuation-in-part of application No. 11/307,271,
filed on Jan. 30, 2006.

(51) **LOC (9) Cl.** **12-12**

(52) **U.S. Cl.** **D12/319**

(58) **Field of Classification Search** D12/319,
D12/343, 345; 244/45 R, 45 A, 13, 15
See application file for complete search history.

(56) **References Cited**

U.S. PATENT DOCUMENTS

3,576,300 A 4/1971 Palfreyman
3,727,862 A 4/1973 Kaufhold et al.
4,019,699 A 4/1977 Wintersdorff et al.

(Continued)

OTHER PUBLICATIONS

Meyer Reshotko, Jack H. Goodykoontz and Robert G. Dorsch,
“Engine-Over-the-Wing Noise Research”, J. Aircraft, Apr. 1974, pp.
195-196, Vol. 11, No. 4.

“Noise-Reduction Benefits Analyzed for Over-the-Wing-Mounted
Advanced Turbofan Engine (Synopsis)”, [www-paso.grc.nasa.gov/
Library/Abstracts/berton6.html](http://www-paso.grc.nasa.gov/Library/Abstracts/berton6.html), Jan. 20, 2006, pp. 1-2.

(Continued)

Primary Examiner—Lisa P Lichtenstein

(74) *Attorney, Agent, or Firm*—Matthew W. Witsil; Moore &
Van Allen PLLC

(57) **CLAIM**

The ornamental design for an aircraft, as shown and
described.

DESCRIPTION

FIG. 1 is a perspective view of a first embodiment of an
aircraft showing my new design;

FIG. 2 is a left side view of the aircraft as shown in FIG. 1
showing our new design, which is a mirror image of the right
side view;

FIG. 3 is a top view of the aircraft as shown in FIG. 1 showing
our new design;

FIG. 4 is a bottom view of the aircraft as shown in FIG. 1
showing our new design;

FIG. 5 is a front view of the aircraft as shown in FIG. 1
showing our new design;

FIG. 6 is a back view of the aircraft as shown in FIG. 1
showing our new design;

FIG. 7 is a perspective view of a second embodiment of an
aircraft showing our new design;

FIG. 8 is a left side view of the aircraft as shown in FIG. 7
showing our new design, which is a mirror image of the right
side view;

FIG. 9 is a top view of the aircraft as shown in FIG. 7 showing
our new design;

FIG. 10 is a bottom view of the aircraft as shown in FIG. 7
showing our new design;

FIG. 11 is a front view of the aircraft as shown in FIG. 7
showing our new design; and,

FIG. 12 is a back view of the aircraft as shown in FIG. 7
showing our new design.

The broken line showing of portions of an aircraft is included
for the purpose of illustrating environmental structure and
forms no part of the claimed design.

1 Claim, 10 Drawing Sheets

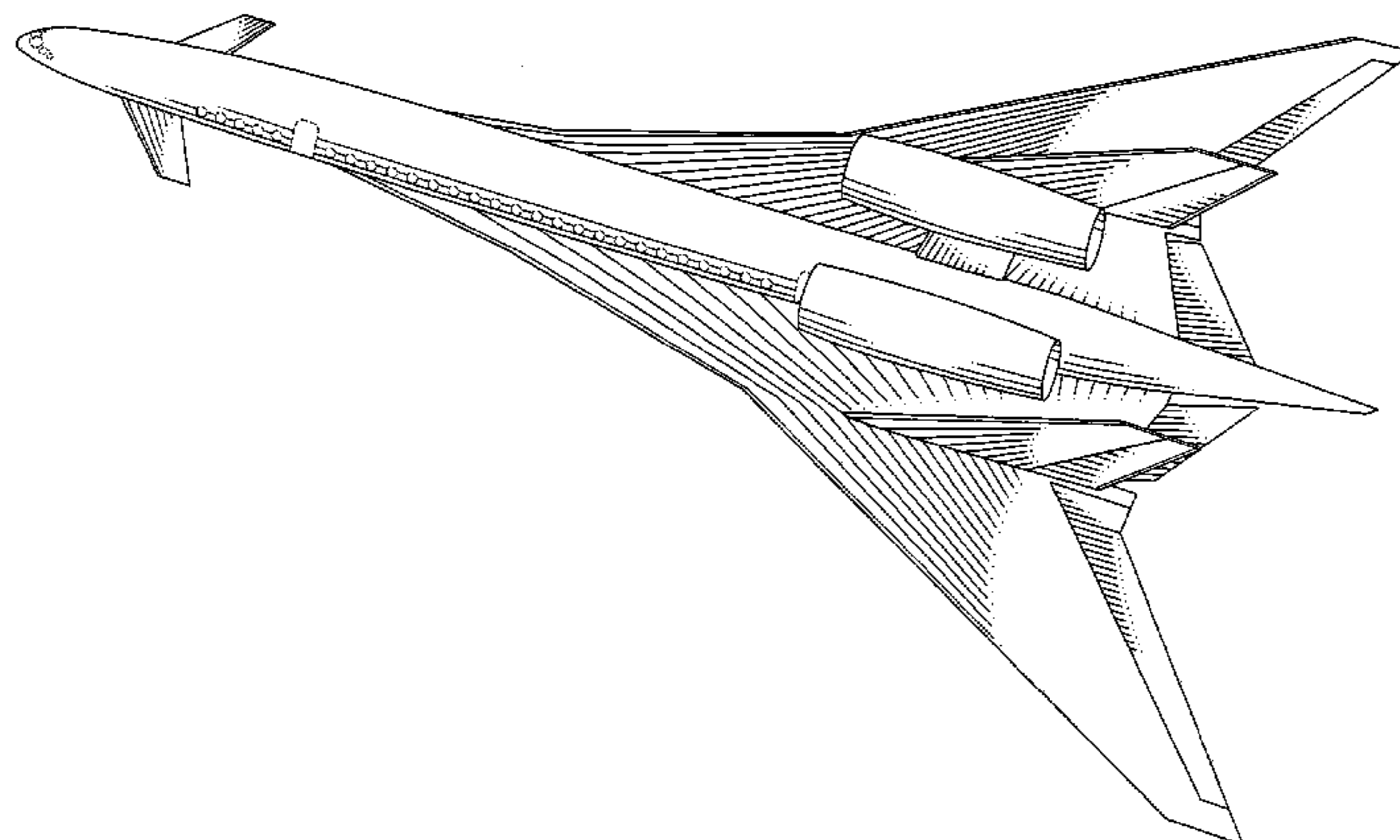

US D622,653 S

Page 2

U.S. PATENT DOCUMENTS

4,036,452 A 7/1977 Schairer
4,171,786 A 10/1979 Krenz
4,311,289 A 1/1982 Finch
4,447,022 A 5/1984 Lion
4,449,680 A 5/1984 Gratzner et al.
4,836,469 A 6/1989 Wagenfeld
5,348,256 A 9/1994 Parikh
5,738,298 A 4/1998 Ross et al.
6,102,328 A 8/2000 Kumata et al.
6,308,913 B1 10/2001 Fujino et al.
D516,995 S * 3/2006 Eatkins et al. D12/319

D566,031 S * 4/2008 Beaunis et al. D12/319

OTHER PUBLICATIONS

Mizrahi, "Flight to the Future", Jan. 20, 2006, www.twitt.org/bldwing.htm, pp. 1-9.
"Stealth Aircraft the Technology behind the planes", www.seorf.ohiou.edu, Jan. 20, 2006, pp. 1-12.
Geoffrey A. Hill and Russell H. Thomas, "Challenges and Opportunities for Noise Reduction Through Advanced Aircraft Propulsion Airframe Integration and Configurations", 8th CEAS Workshop: Aeroacoustics of New Aircraft and Engine Configurations, Budapest, Hungary, 2004, pp. 1-13.

* cited by examiner

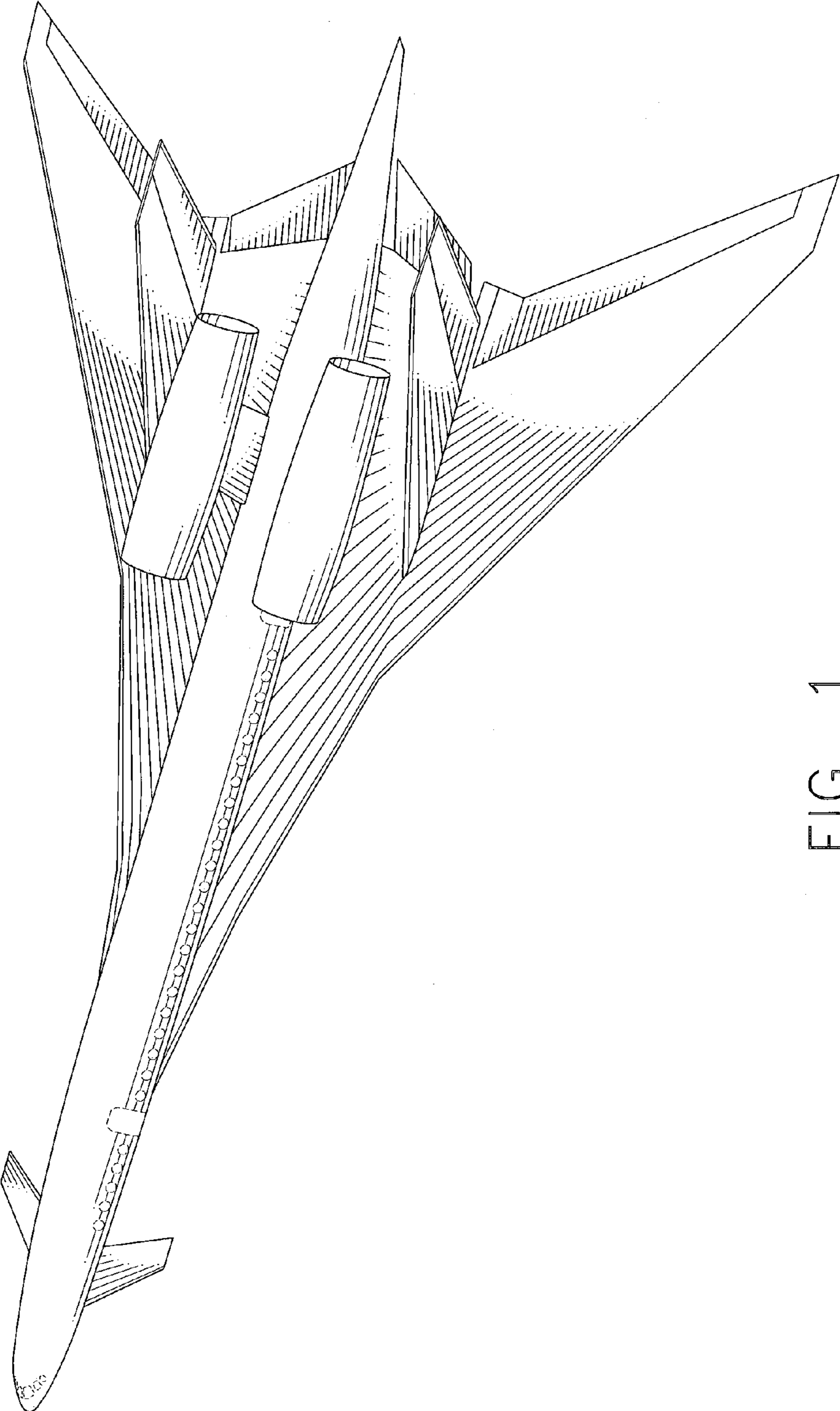

FIG. 1

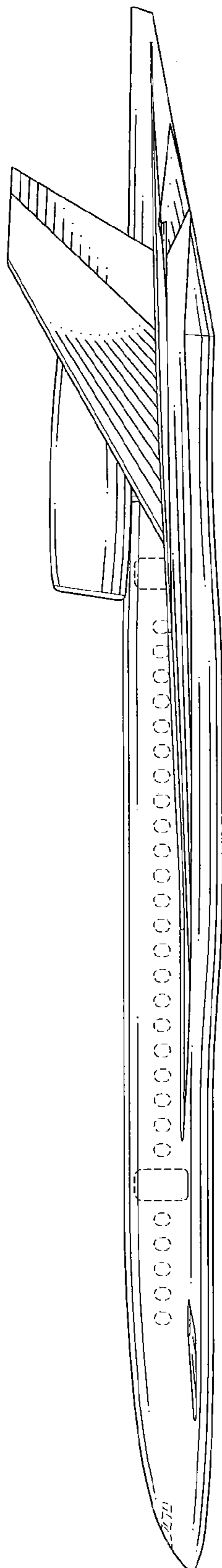

FIG. 2

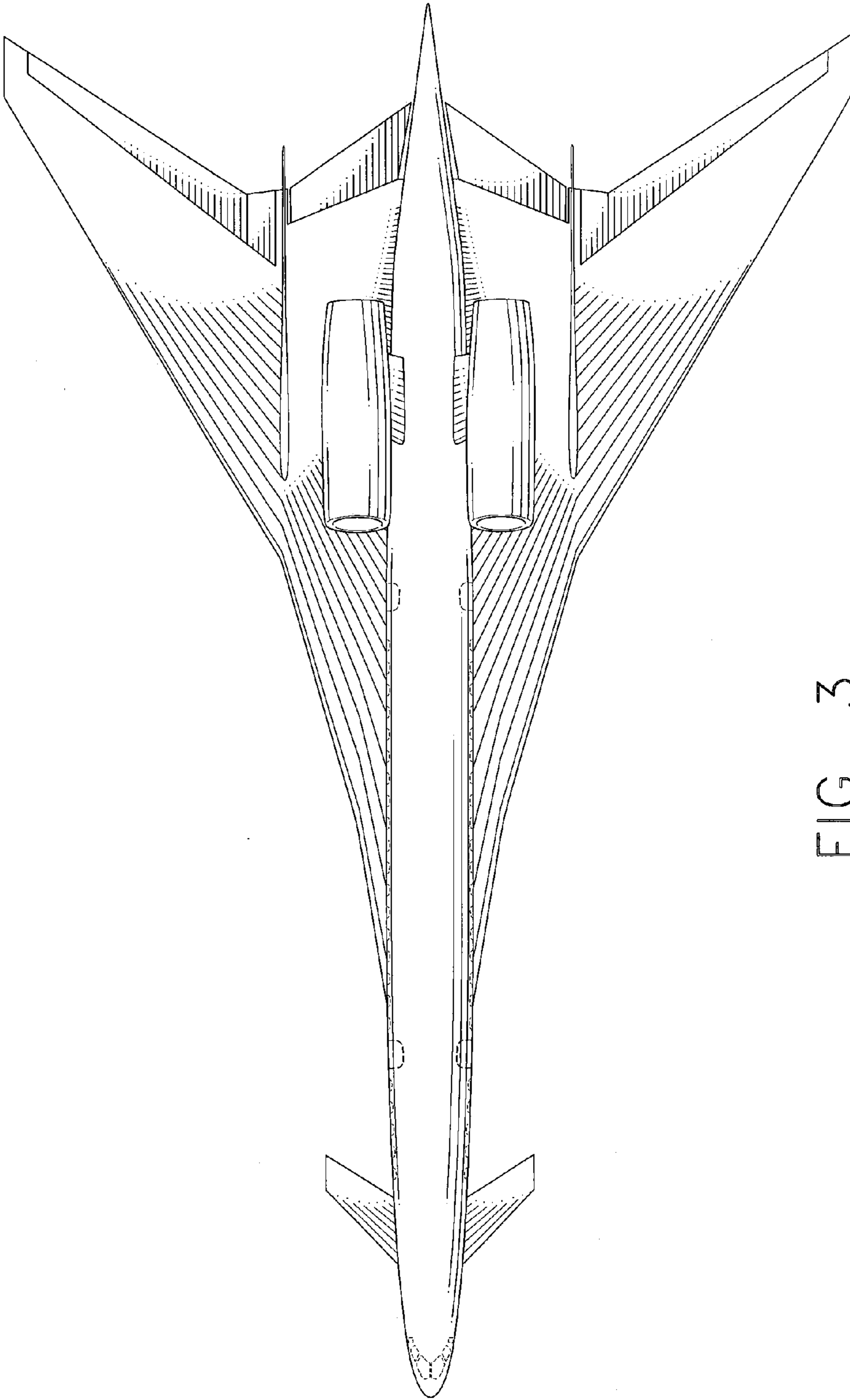

FIG. 3

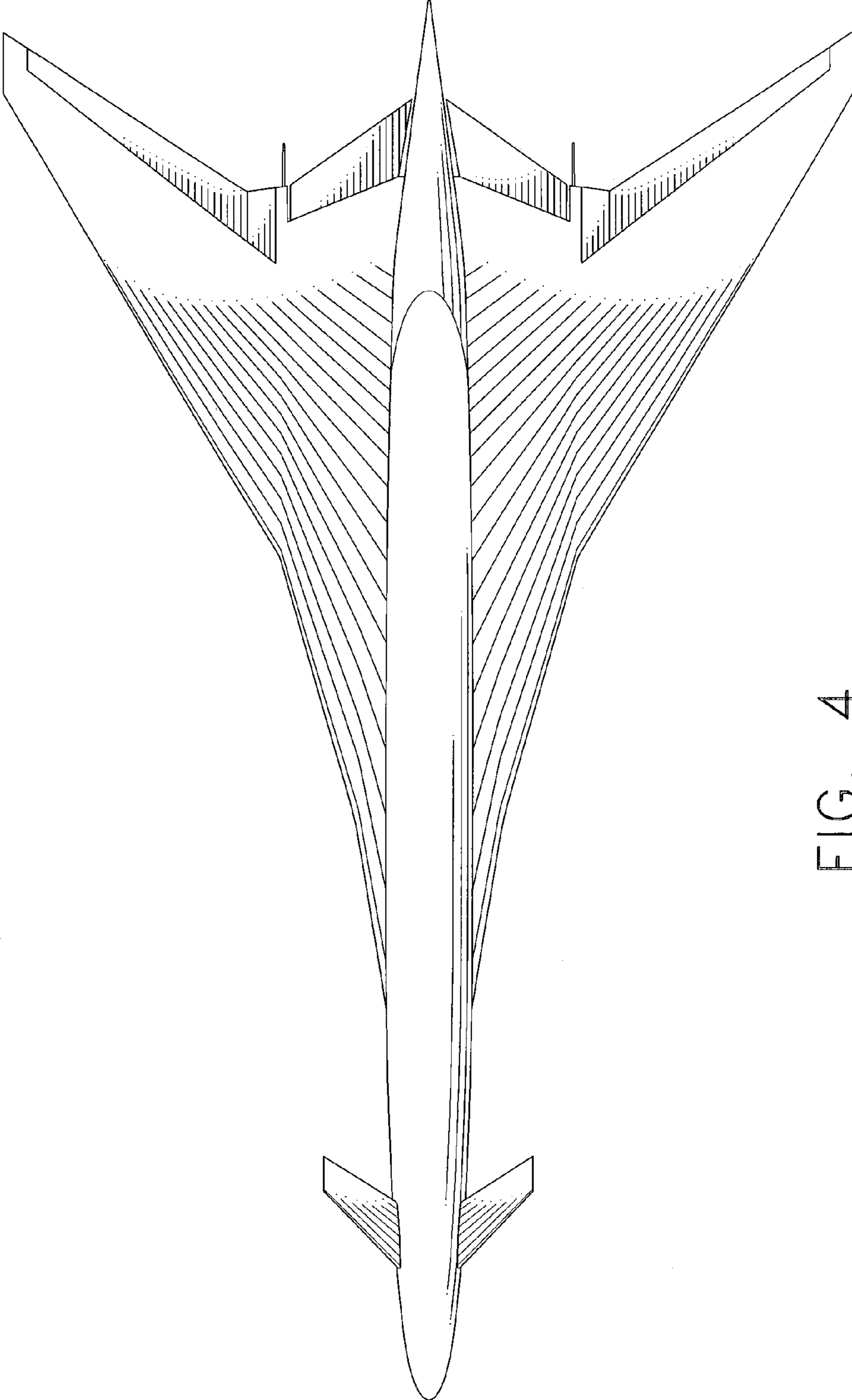

FIG. 4

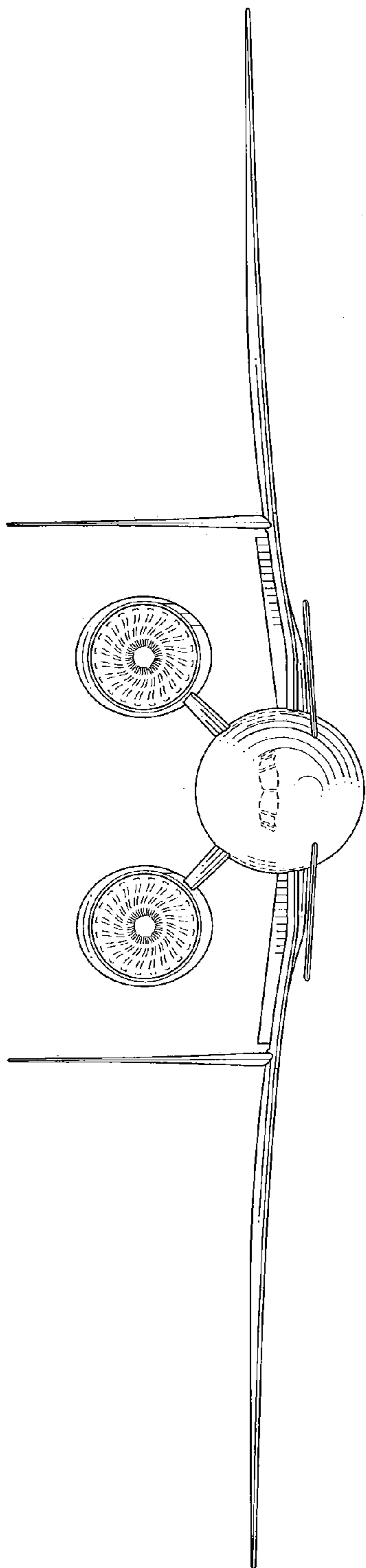

FIG. 5

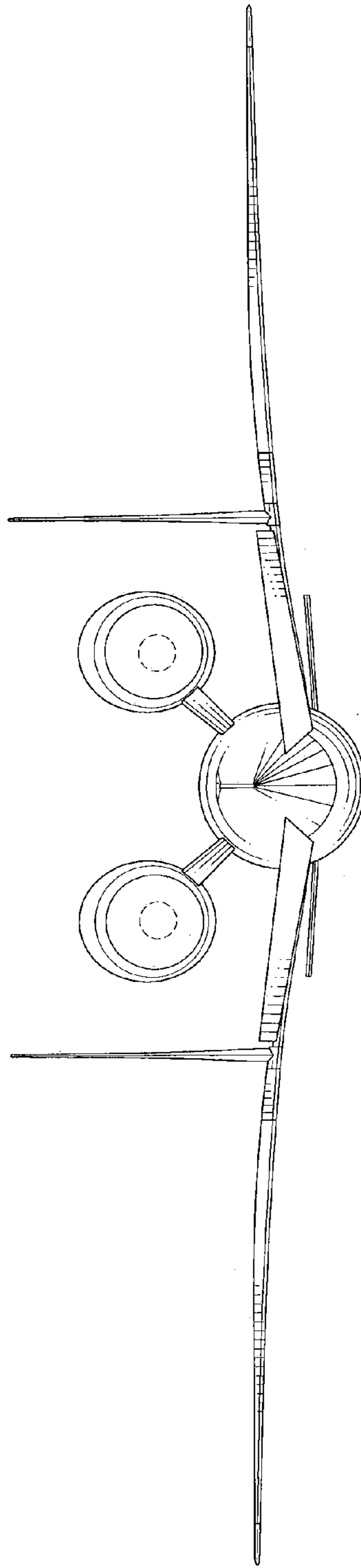

FIG. 6

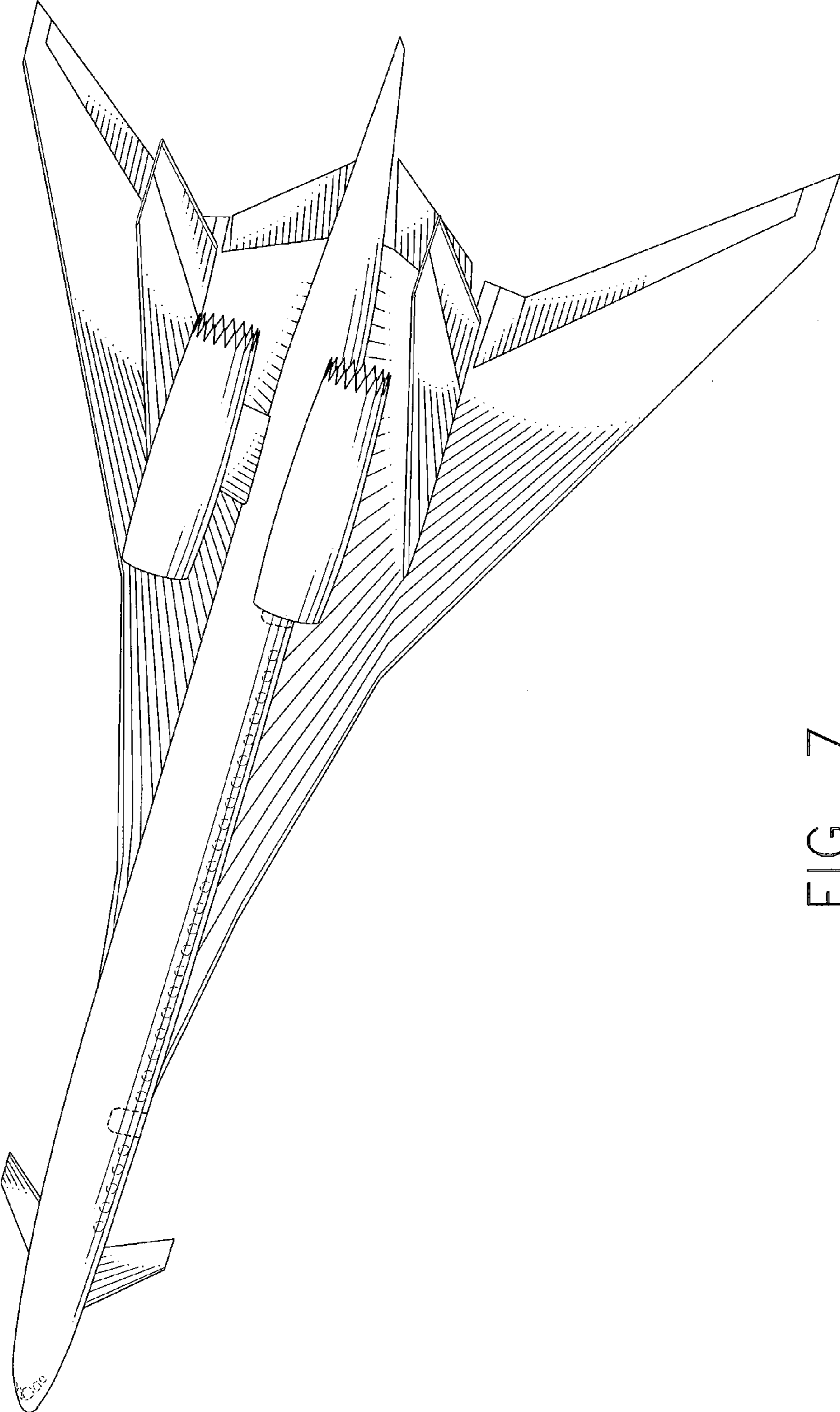

FIG. 7

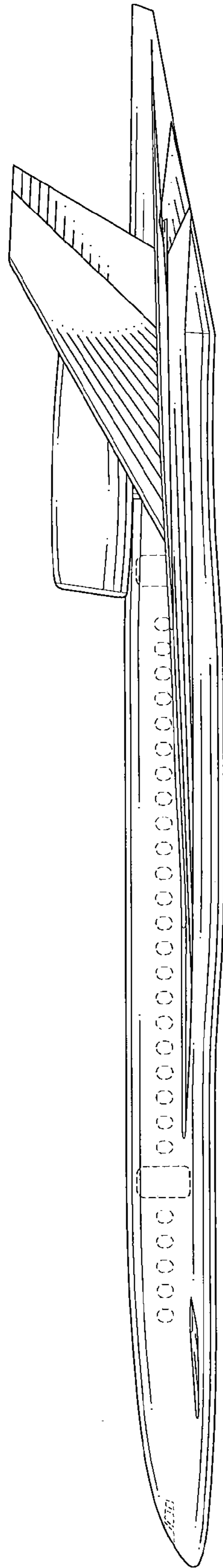

FIG. 8

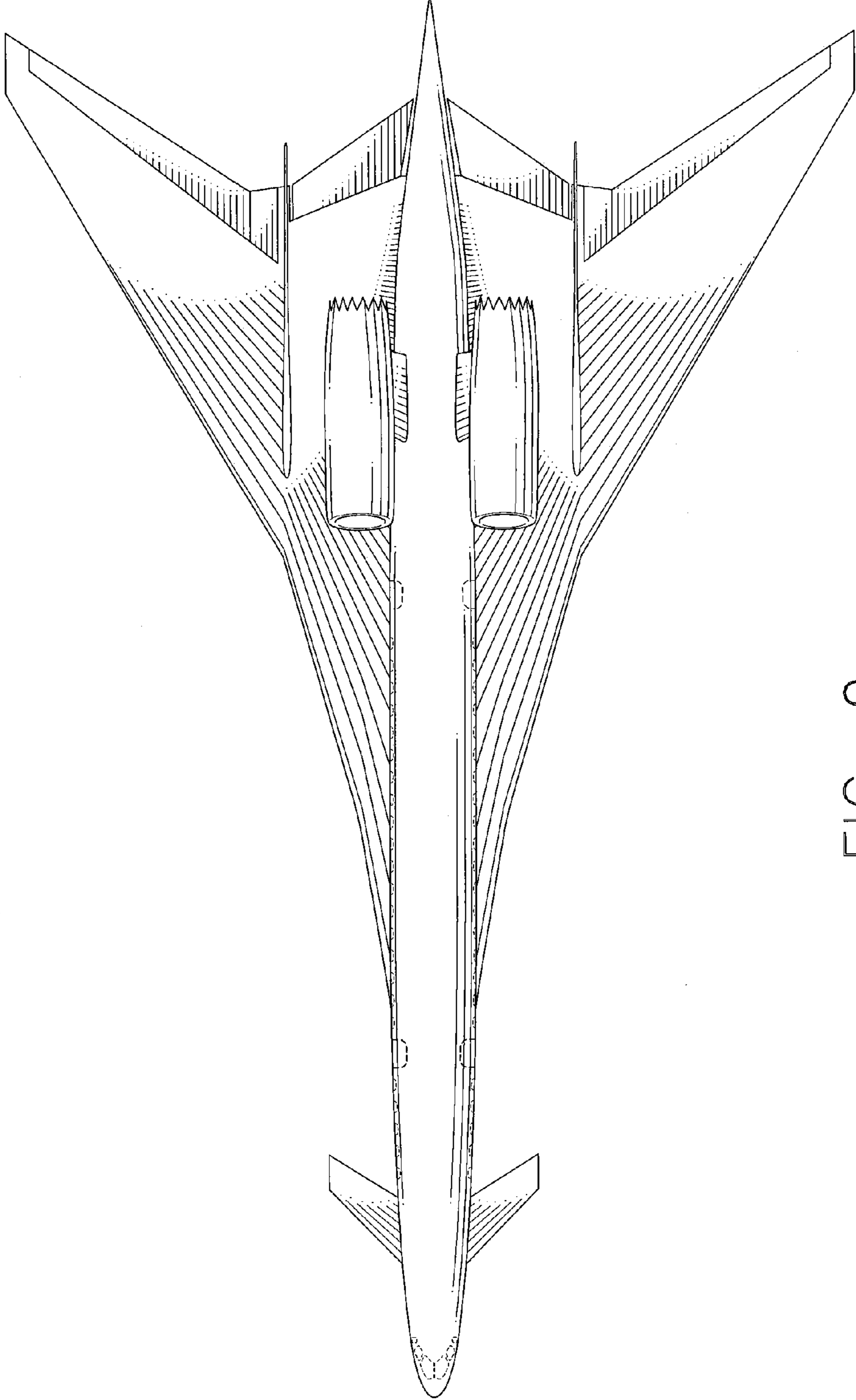

FIG. 9

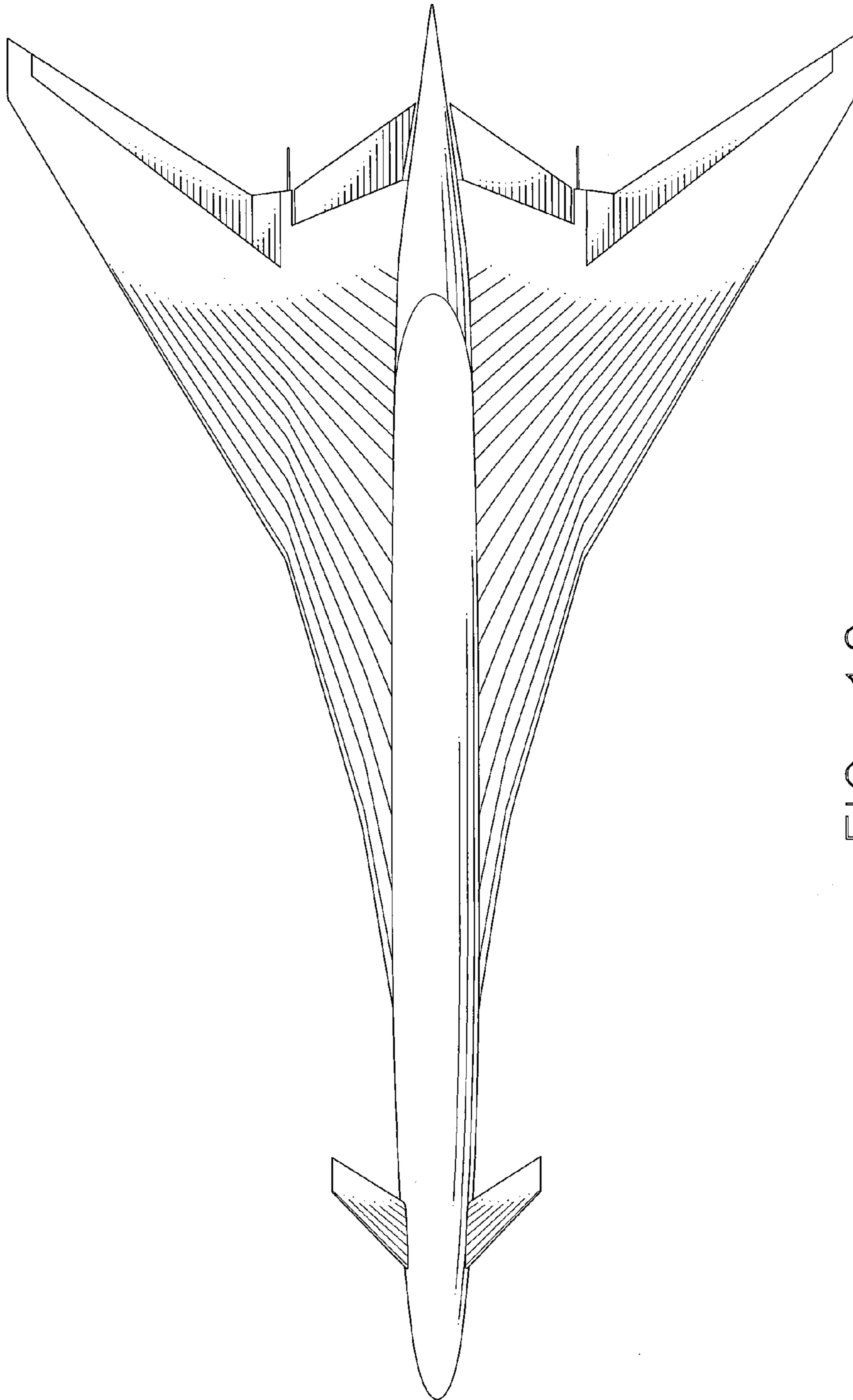

FIG. 10

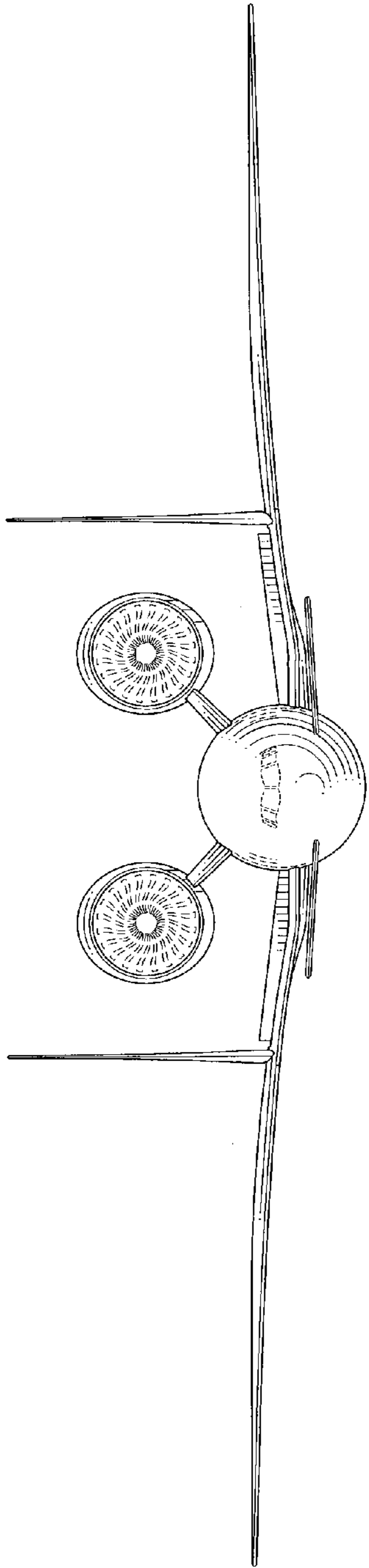

FIG. 11

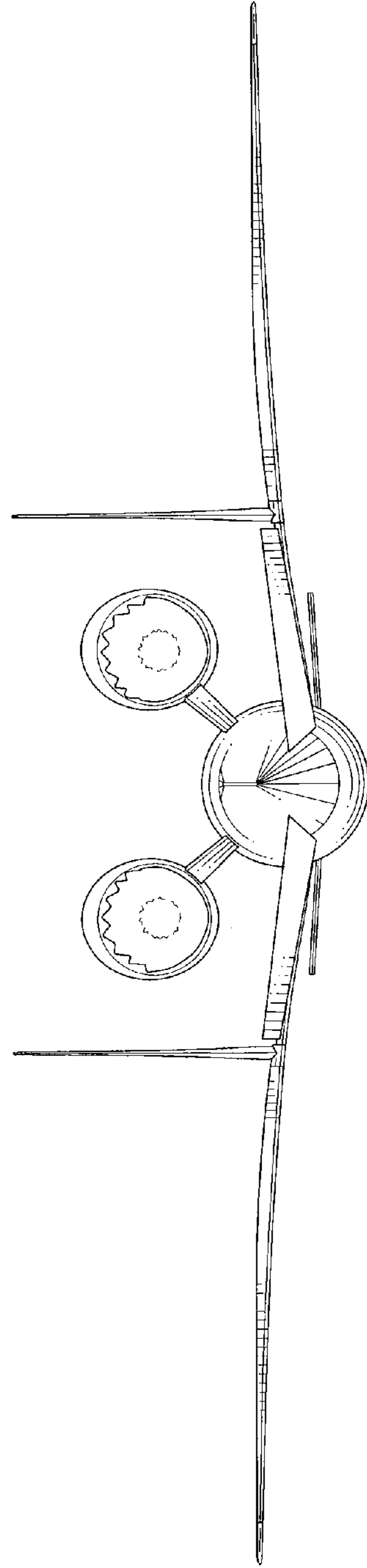

FIG. 12