



US00D622646S

(12) **United States Design Patent**
Arbesman et al.

(10) **Patent No.:** **US D622,646 S**

(45) **Date of Patent:** **** Aug. 31, 2010**

(54) **BRAKE PAD UNIT WITH REPLACEABLE FRICTION ELEMENTS**

(76) Inventors: **Ray Arbesman**, 42 Burton Road, Toronto, Ontario (CA) M5P 1V2; **Nghi Pham**, 100 Prairie Dunes Place, Concord, Ontario (CA) L4K 2E4; **Stewart Kahan**, 115 Laporte Street, Dollard-des-Ormeaux, Quebec (CA) H9A 3E3

(**) Term: **14 Years**

(21) Appl. No.: **29/350,773**

(22) Filed: **Nov. 23, 2009**

(30) **Foreign Application Priority Data**

Jun. 22, 2010 (CA) 132913

(51) **LOC (9) Cl.** **12-16**

(52) **U.S. Cl.** **D12/180**

(58) **Field of Classification Search** D12/180;
188/71.1, 73.3, 73.31-73.39, 72.2, 72.4,
188/73.41-73.46, 218 XL, 370, 1.11 W, 264 A,
188/264 AA, 18 A; 192/169.2, 169.3, 107 R
See application file for complete search history.

(56) **References Cited**

U.S. PATENT DOCUMENTS

4,362,225	A	12/1982	Drott	
5,429,215	A	7/1995	King	
5,499,705	A	3/1996	Ide	
5,538,104	A	7/1996	Katz et al.	
5,732,800	A	3/1998	Spigener	
5,743,361	A	4/1998	Winter	
5,842,546	A *	12/1998	Biswas	188/73.37
6,244,396	B1	6/2001	Lumpkin	
6,367,594	B1 *	4/2002	Barbosa et al.	188/73.1
D506,423	S *	6/2005	Matsumoto	D12/180

D507,773	S *	7/2005	Ono	D12/180
6,983,831	B2 *	1/2006	Beri	188/250 B
7,051,847	B2	5/2006	Wirth	
D608,708	S *	1/2010	Liu et al.	D12/180
D610,509	S *	2/2010	Liu et al.	D12/180
D612,780	S *	3/2010	Liu et al.	D12/180

FOREIGN PATENT DOCUMENTS

CA	2081209	10/1992
CA	2226358	8/1998
CA	2642966	6/2008
EP	1 180 612	2/2002
EP	1 691 102	8/2006
FR	2446962	8/1980
FR	2745349	8/1997
GB	1485701	9/1977
JP	2008-106850	5/2008

* cited by examiner

Primary Examiner—Melody N Brown

(74) *Attorney, Agent, or Firm*—Patterson & Sheridan, LLP

(57) **CLAIM**

The ornamental design for a brake pad unit with replaceable friction elements, as shown and described.

DESCRIPTION

FIG. 1 is a top perspective view of a brake pad unit with replaceable friction elements showing our new design;

FIG. 2 is a top view thereof;

FIG. 3 is a bottom view thereof;

FIG. 4 is a front view thereof;

FIG. 5 is a rear view thereof;

FIG. 6 is a side view thereof;

FIG. 7 is an opposite side view thereof; and;

FIG. 8 is an exploded perspective view thereof.

1 Claim, 5 Drawing Sheets

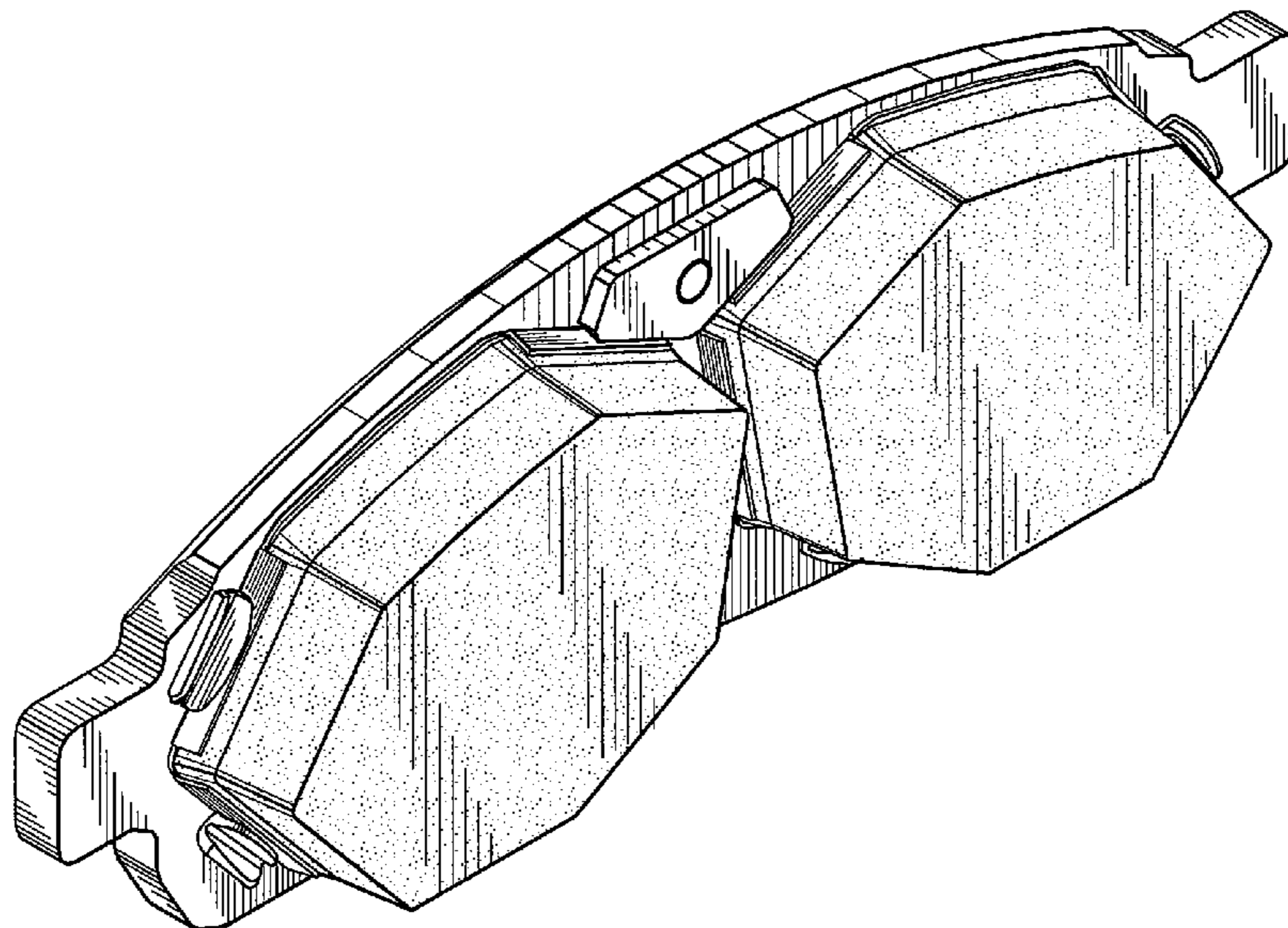

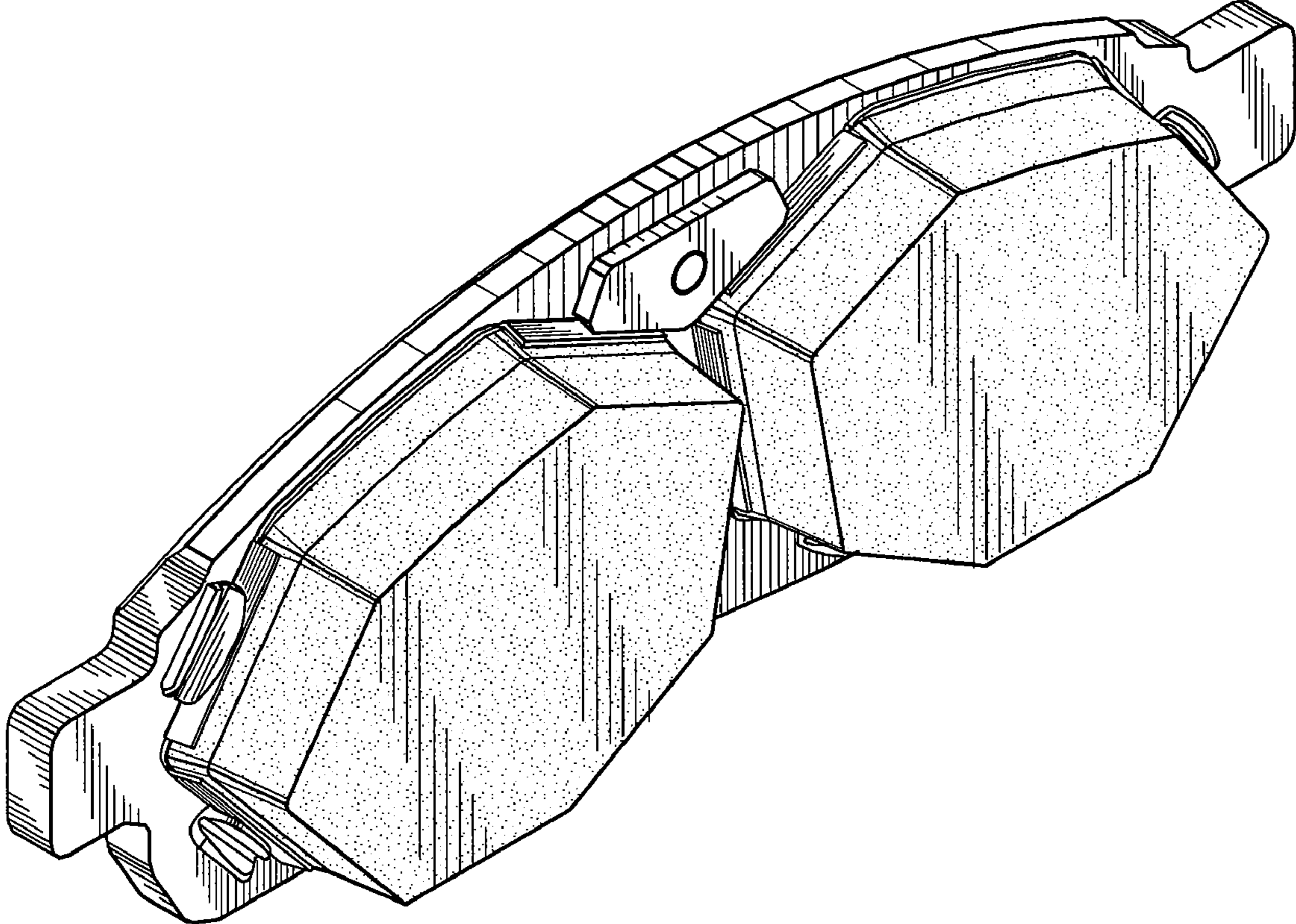

FIG.1

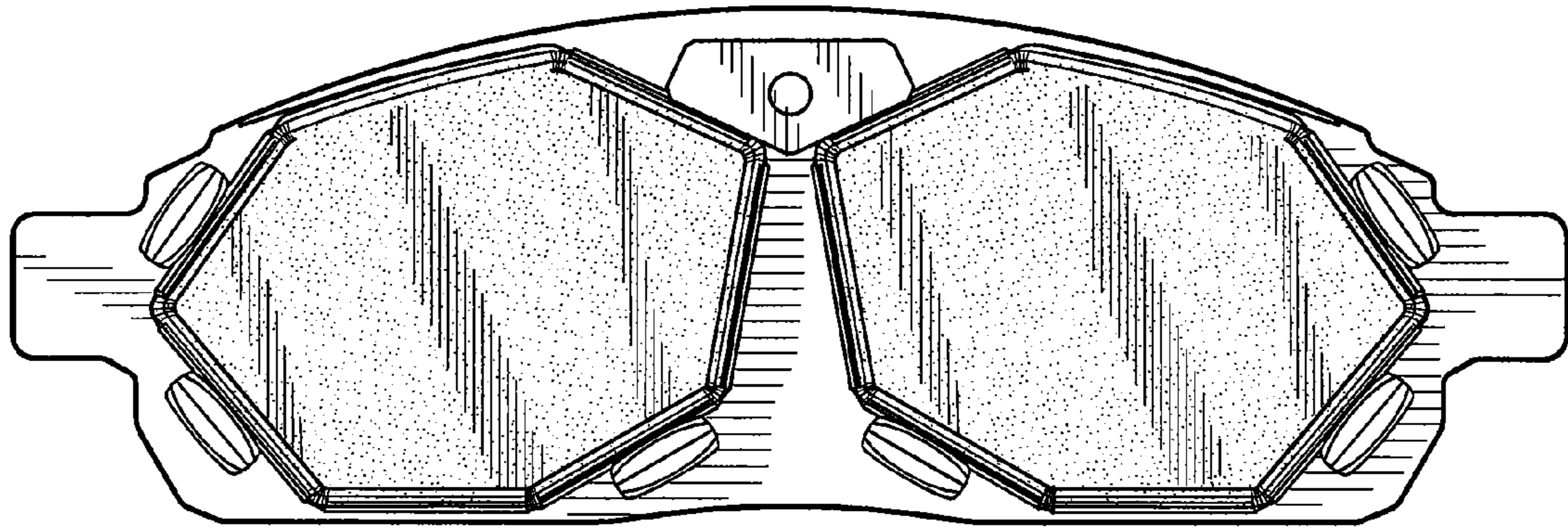

FIG. 2

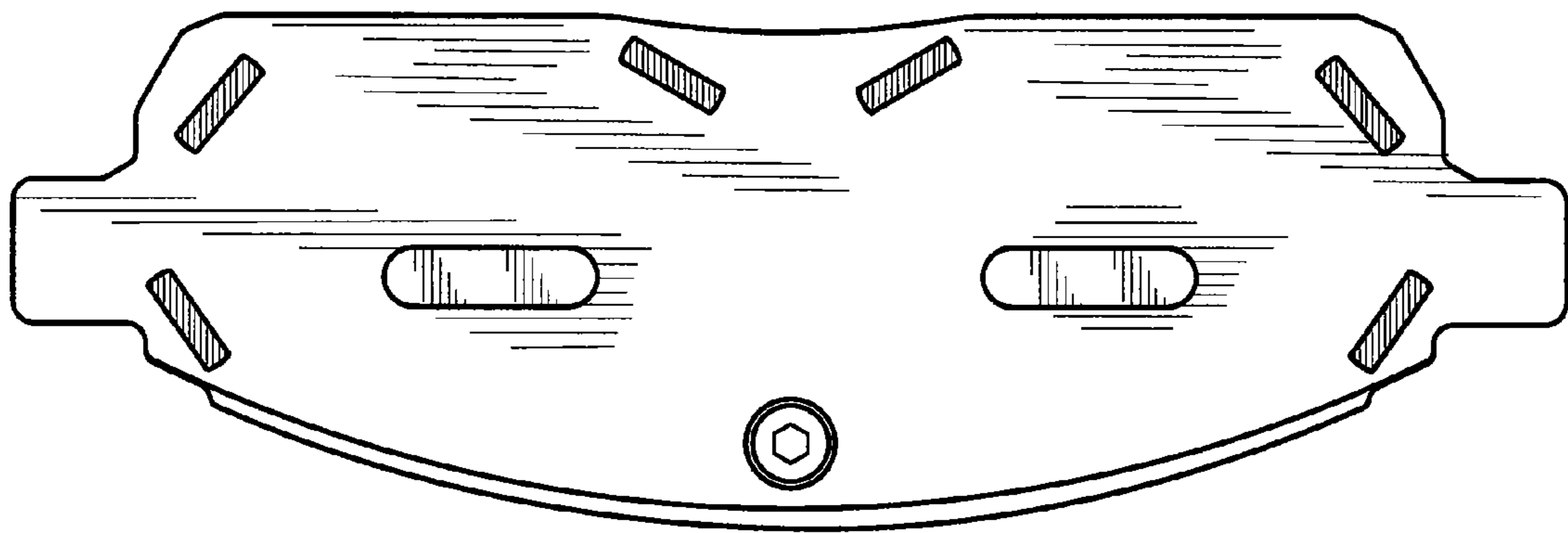

FIG. 3

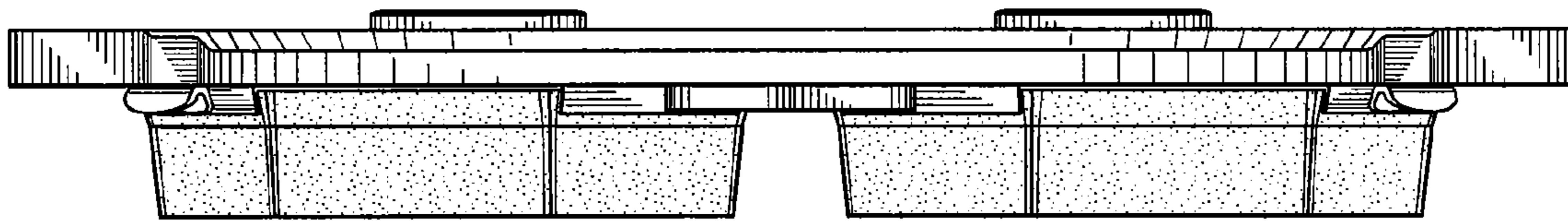

FIG. 4

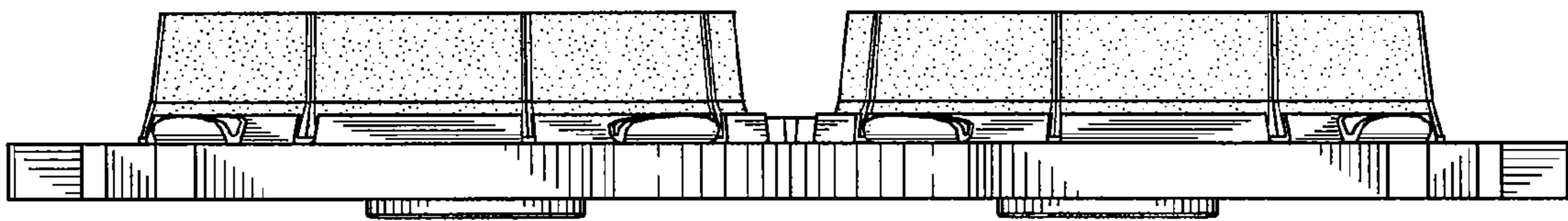

FIG. 5

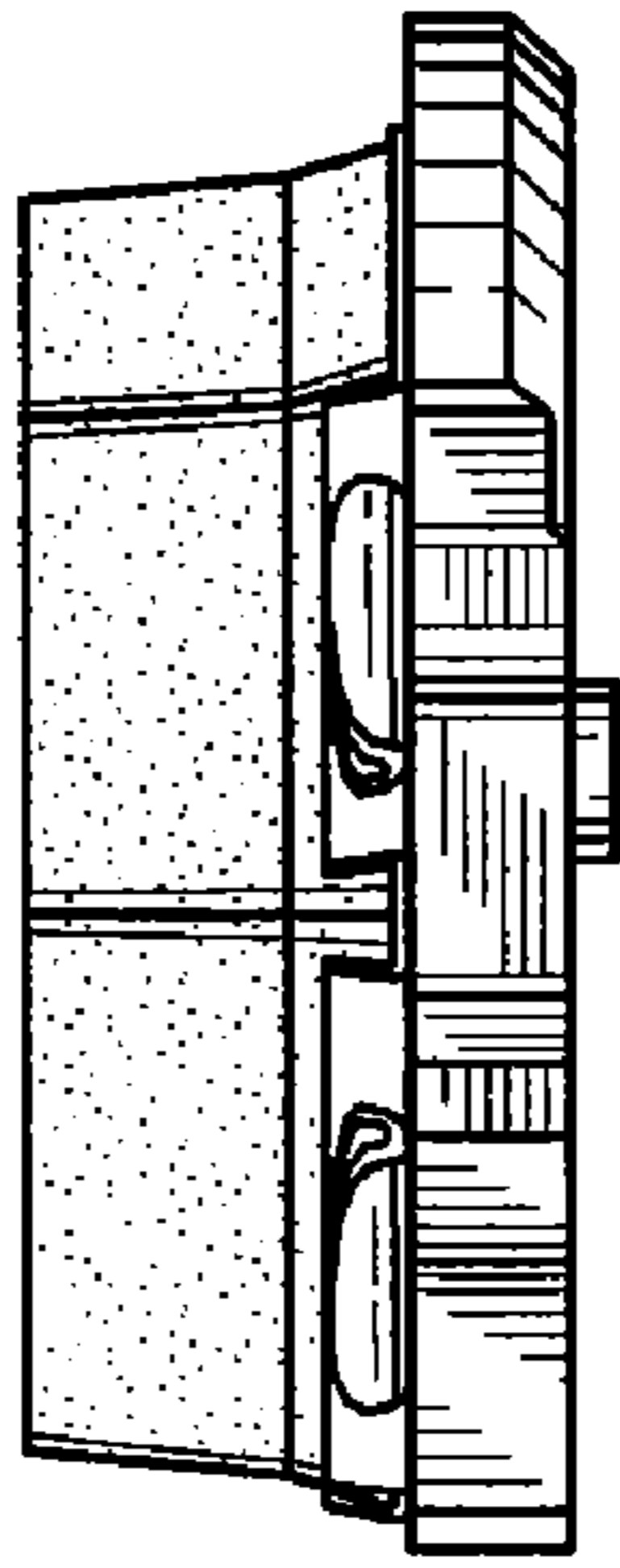

FIG. 6

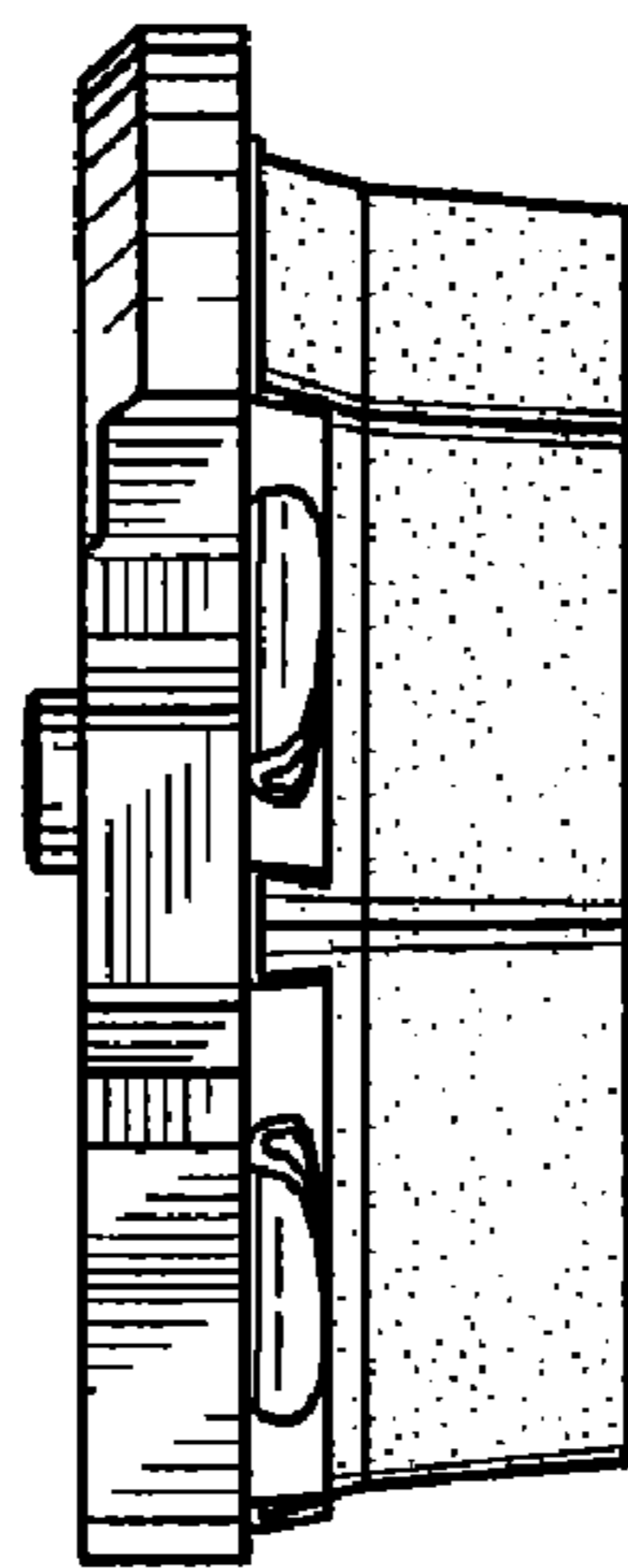

FIG. 7

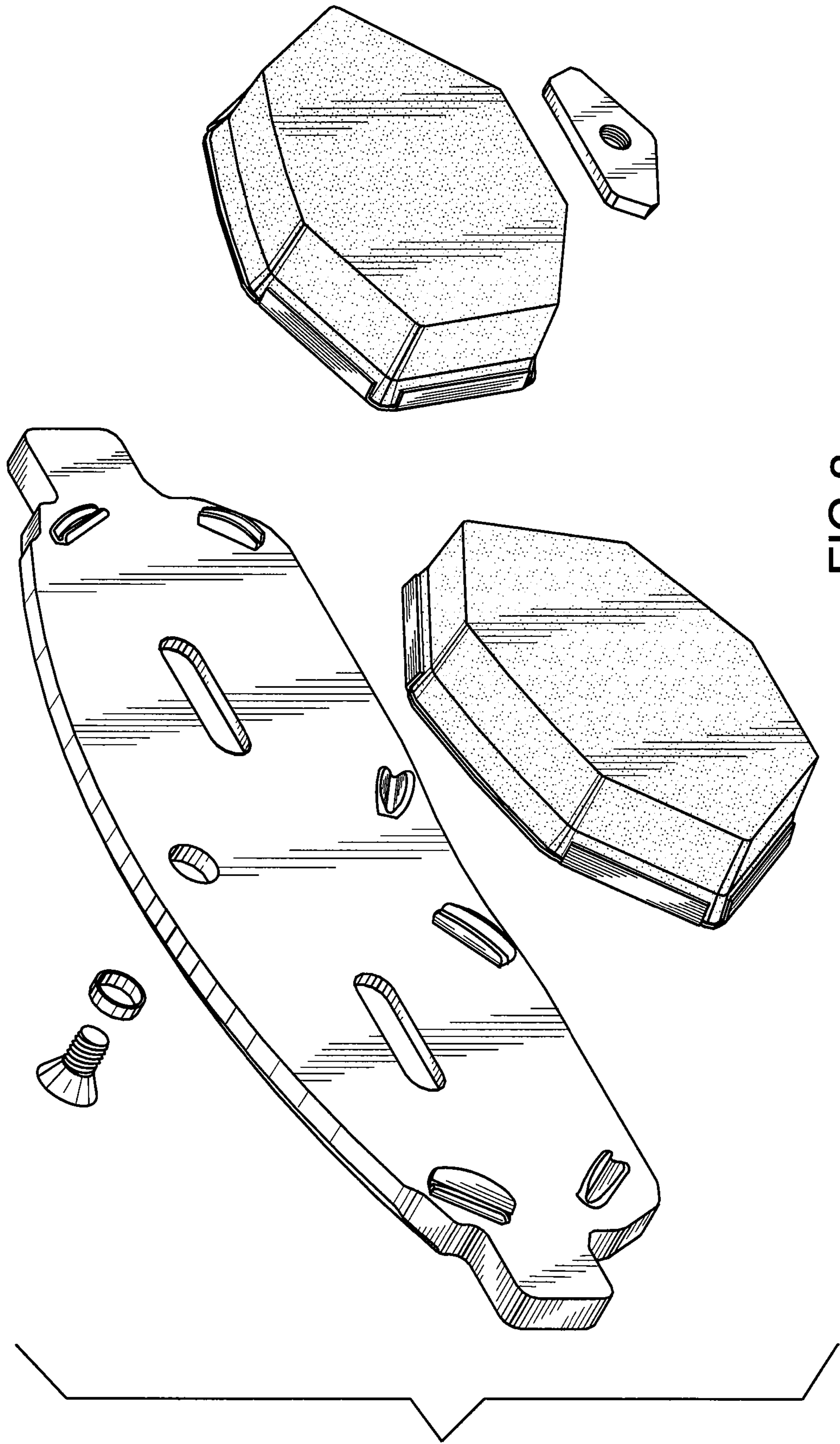

FIG.8