



US00D622636S

(12) **United States Design Patent**
Cheng

(10) **Patent No.:** **US D622,636 S**

(45) **Date of Patent:** **** Aug. 31, 2010**

(54) **MOTORCYCLE**

(75) Inventor: **Sheng-Hsiung Cheng**, Hsinchu County (TW)

(73) Assignee: **Sanyang Industry Co., Ltd.**, Hsinchu County (TW)

(**) Term: **14 Years**

(21) Appl. No.: **29/339,653**

(22) Filed: **Jul. 3, 2009**

(30) **Foreign Application Priority Data**

May 20, 2009 (TW) 98302311

(51) **LOC (9) Cl.** **12-11**

(52) **U.S. Cl.** **D12/110**

(58) **Field of Classification Search** D12/110;
180/219, 220

See application file for complete search history.

(56) **References Cited**

U.S. PATENT DOCUMENTS

- D286,521 S * 11/1986 Tanaka et al. D12/110
- D290,824 S * 7/1987 Miura et al. D12/110
- D399,174 S * 10/1998 Takeshita et al. D12/110
- D427,944 S * 7/2000 Sakuma et al. D12/110

- D443,849 S * 6/2001 Chen D12/110
- D455,677 S * 4/2002 Kokubu et al. D12/110
- D480,661 S * 10/2003 Kawawa et al. D12/110
- D493,122 S * 7/2004 Huang et al. D12/110
- D529,415 S * 10/2006 Shimada et al. D12/110
- D586,700 S * 2/2009 Chiu et al. D12/110

* cited by examiner

Primary Examiner—Susan M Lee

Assistant Examiner—Linda G. Brooks

(57) **CLAIM**

The ornamental design for a motorcycle, as shown and described.

DESCRIPTION

FIG. 1 is a front perspective view thereof;

FIG. 2 is a front elevational view thereof;

FIG. 3 is a rear elevational view thereof;

FIG. 4 is a right side elevational view thereof;

FIG. 5 is a left side elevational view thereof; and,

FIG. 6 is a top plan view thereof.

The broken lines illustrate environmental structure that forms no part of the claimed design.

1 Claim, 6 Drawing Sheets



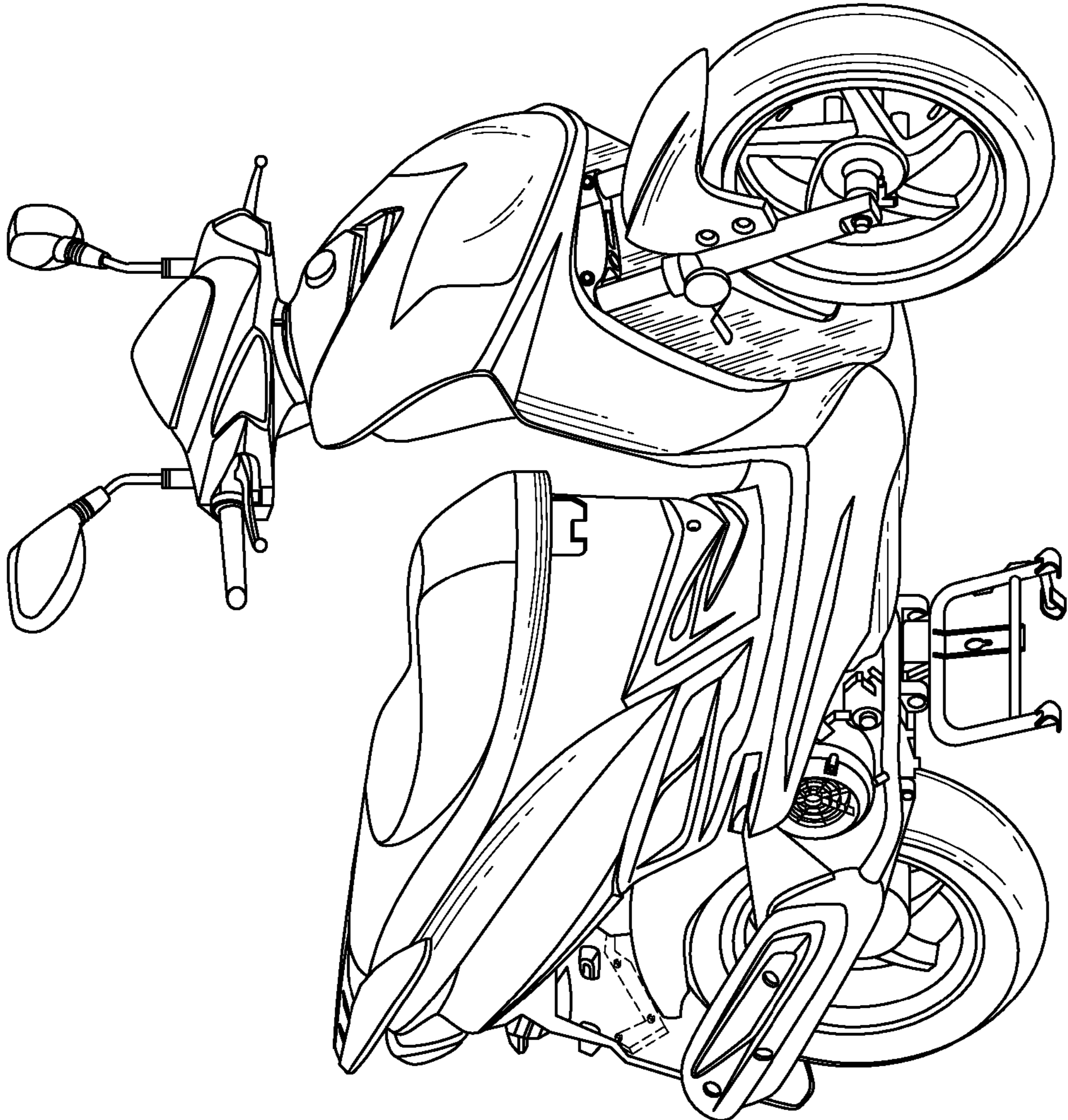

FIG. 1

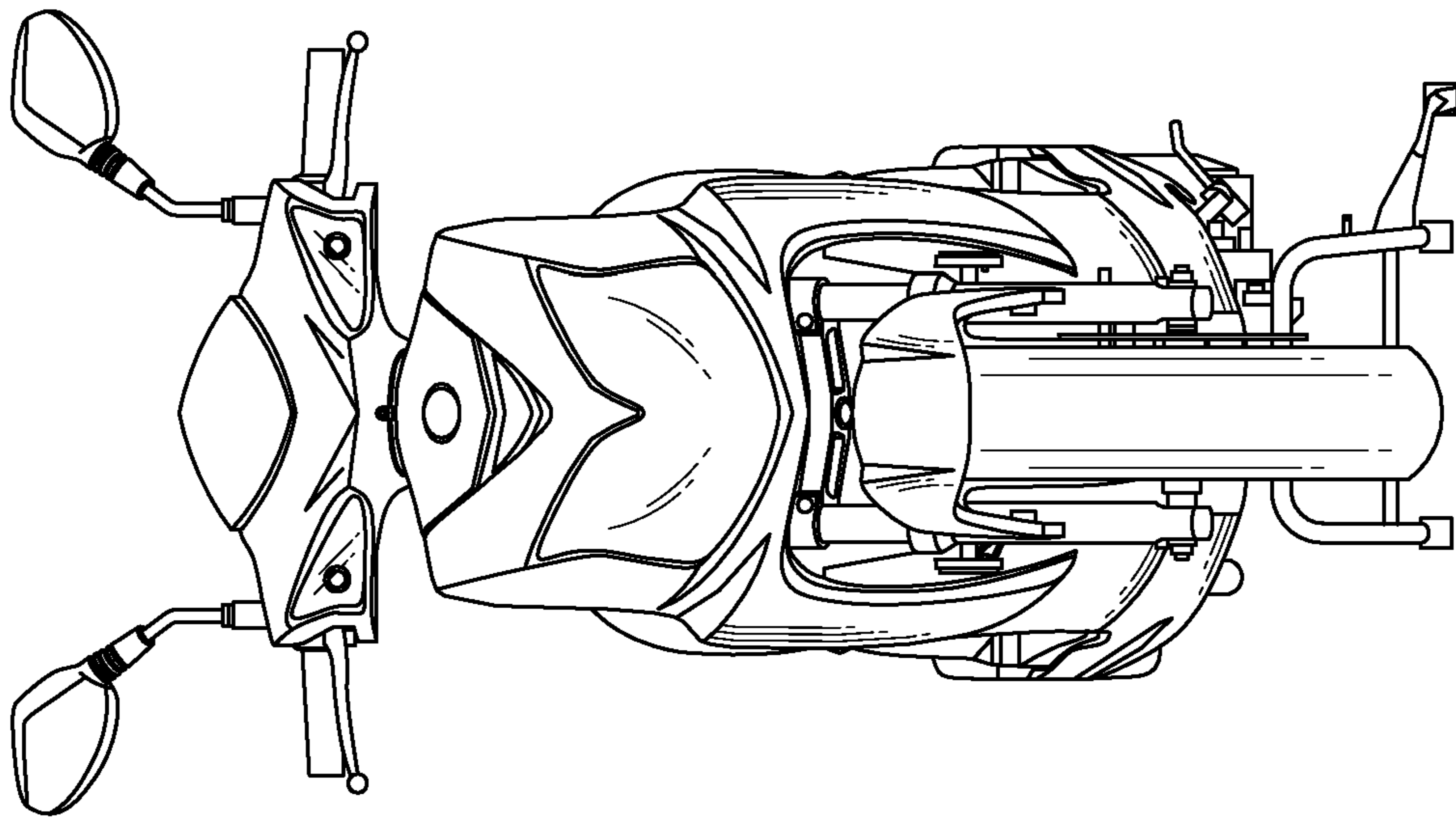

FIG. 2

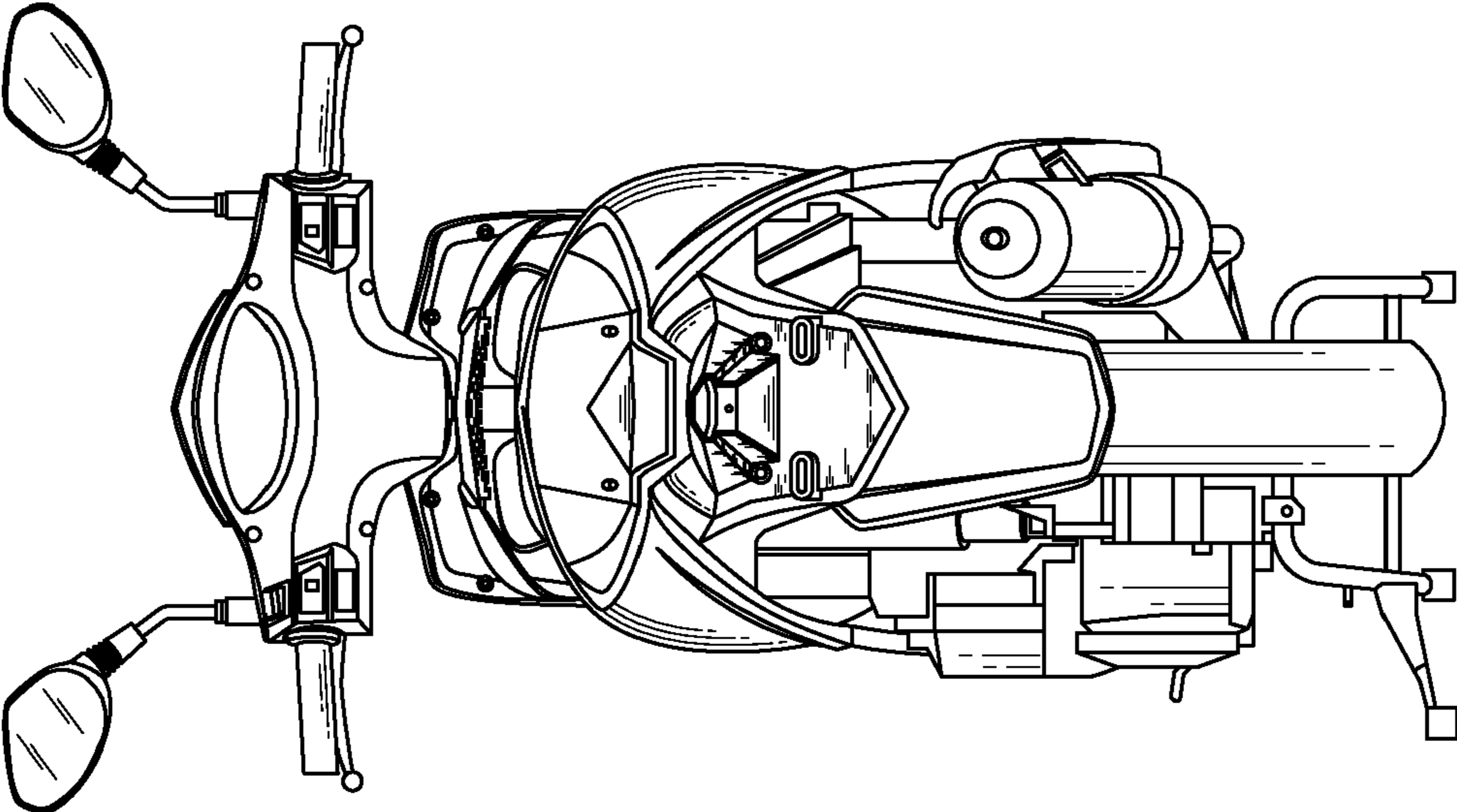

FIG. 3

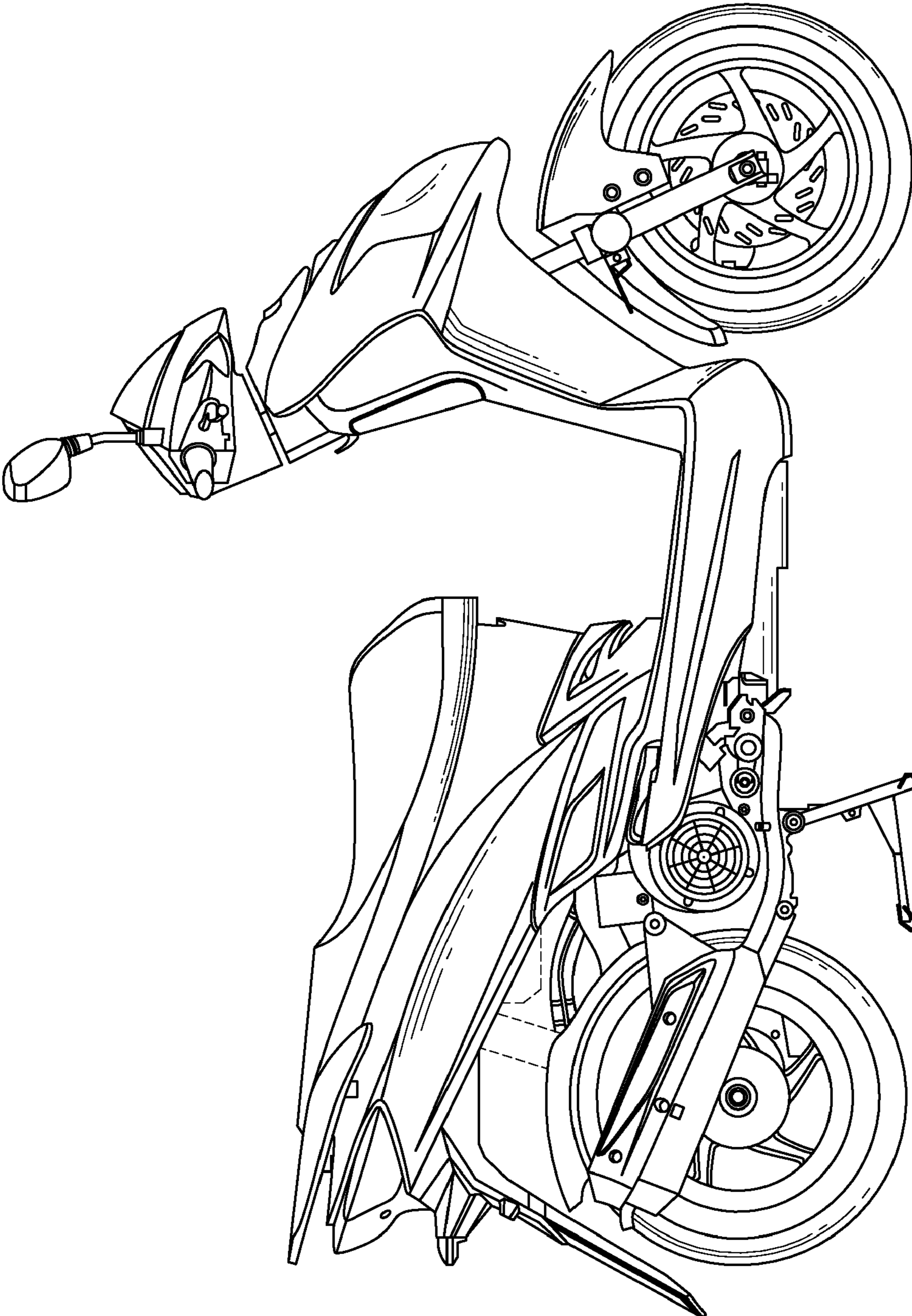

FIG. 4

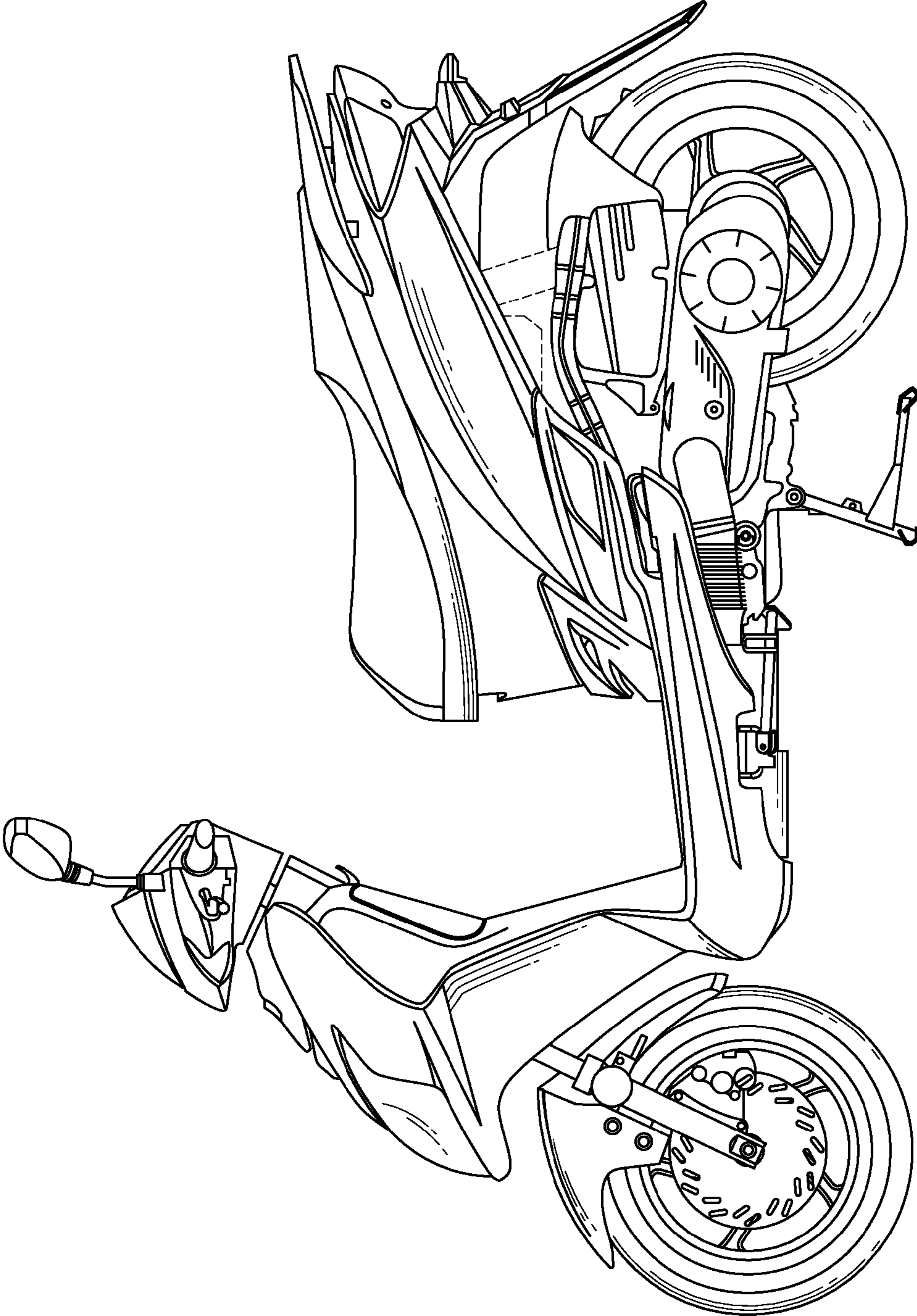

FIG. 5

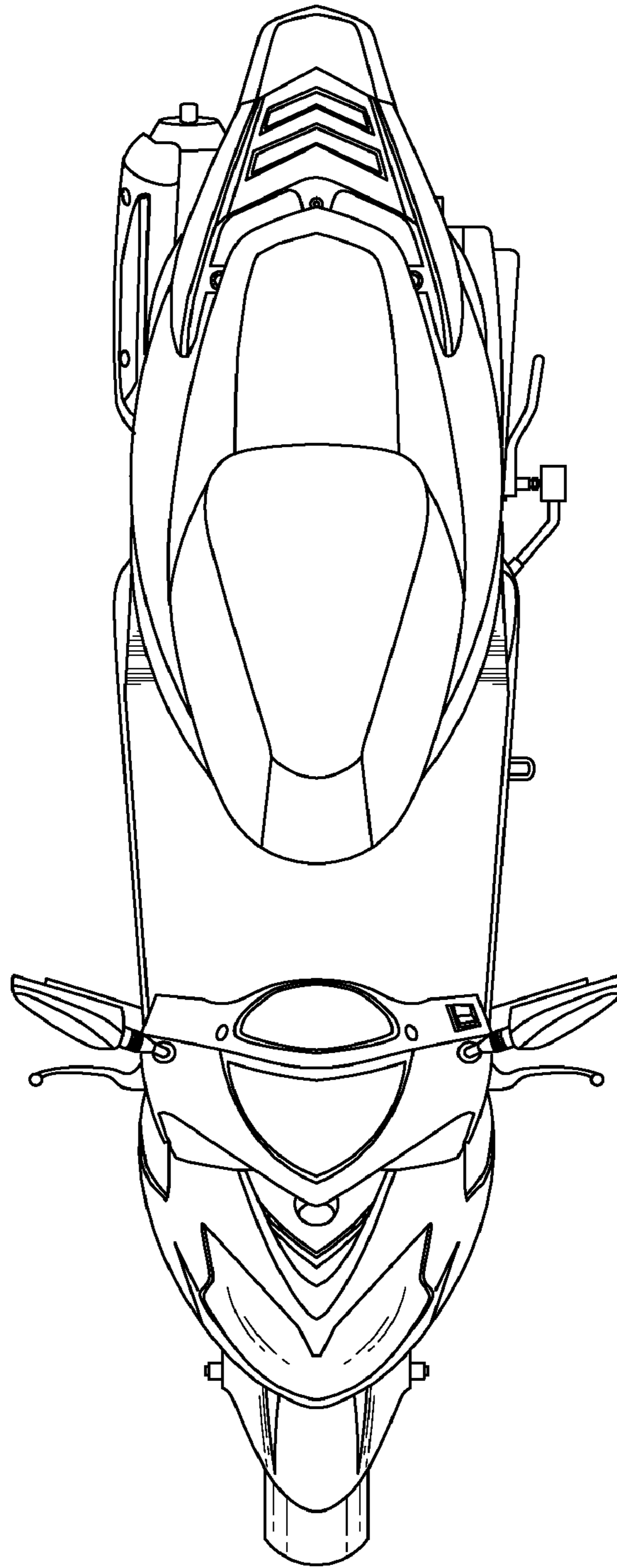

FIG. 6