



US00D622198S

(12) **United States Design Patent**
Jamieson et al.

(10) **Patent No.:** **US D622,198 S**

(45) **Date of Patent:** **** Aug. 24, 2010**

(54) **VEHICLE WHEEL COVER**

(75) Inventors: **Stuart Jamieson**, Chelsea, MI (US);
Freeman Thomas, Laguna Beach, CA
(US); **David Woodhouse**, Newport
Coast, CA (US)

(73) Assignee: **Ford Motor Company**, Dearborn, MI
(US)

(**) Term: **14 Years**

(21) Appl. No.: **29/302,107**

(22) Filed: **Jan. 10, 2008**

(51) **LOC (9) Cl.** **12-16**

(52) **U.S. Cl.** **D12/211**

(58) **Field of Classification Search** D12/204–213;
301/37.101, 64.101, 65

See application file for complete search history.

(56) **References Cited**

U.S. PATENT DOCUMENTS

D419,946 S	*	2/2000	Goplen	D12/211
D455,694 S	*	4/2002	Kaucher	D12/209
D505,371 S	*	5/2005	Hueller	D12/209
D506,964 S	*	7/2005	Sugiyama	D12/209
D507,221 S	*	7/2005	Stopka	D12/209
D522,432 S	*	6/2006	Pfeiffer	D12/209
D529,419 S		10/2006	Richards et al.		
D529,426 S	*	10/2006	Metros et al.	D12/209
D559,742 S		1/2008	Thomas et al.		
D561,646 S		2/2008	Thomas et al.		
D561,658 S		2/2008	Thomas et al.		
D563,277 S		3/2008	Thomas et al.		

OTHER PUBLICATIONS

Roth, Dan; “Detroit Auto Show: Ford Airstream Concept”; Autoblog website article, located at www.autoblog.com/2007/01/07/detroit-auto-show-ford-airstream-concept/; 16 pages; Jan. 7, 2007.

Thomas, David; “2006 L.A. Auto Show: Ford Explorer Fuel Cell”; Cars.com Kicking Tires article, located at http://blogs.cars.com/kickingtires/2006/11/2006_la_auto_sh_4.html; 3 pages; Nov. 28, 2006.

“Ford F-250 Super Chief Concept: A Bold, American Flex Fuel Pickup That Delivers Tomorrow’s Fuel Today”; Ford Motor Company Press Release, located at http://media.ford.com/newsroom/release_display.cfm?release=22295; 5 pages; Jan. 8, 2006.

Pund, Daniel, “The Bold and the Brutiful: Ford designs another rear-drive sport sedan concept,” Edmunds website article, located at <http://www.edmunds.com/insideline/do/Features/articleId=118988>; 2 pages; Dec. 30, 2006.

“2008 Explorer Maintains Leadership Among Midsize SUVs With Unmatched Features And Equipment”; Ford press release posted on Zer Customs website, located at <http://www.zercustoms.com/news/2008-ford-explorer.html>; 3 pages; Jul. 11, 2007.

* cited by examiner

Primary Examiner—Elizabeth A Albert

Assistant Examiner—Kelley A Donnelly

(74) *Attorney, Agent, or Firm*—Frank A. MacKenzie; Brooks Kushman P.C.

(57) **CLAIM**

The ornamental design for a vehicle wheel cover, as shown and described.

DESCRIPTION

FIG. 1 is a front elevational view of the vehicle wheel cover in accordance with the present invention; and,

FIG. 2 is a front/side perspective view of the vehicle wheel cover of FIG. 1.

The broken lines are for environmental purposes only and form no part of the claimed design.

1 Claim, 2 Drawing Sheets

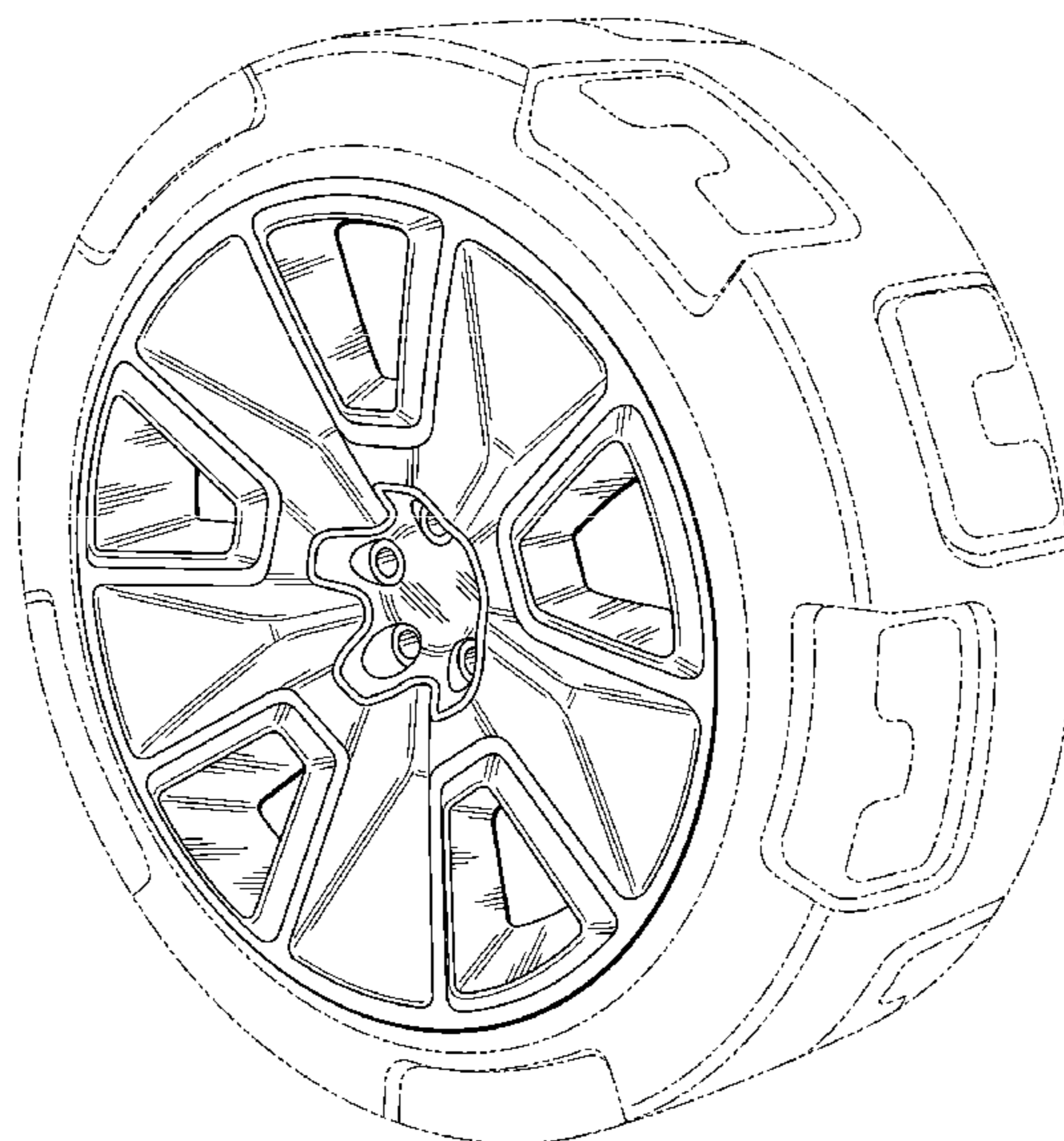

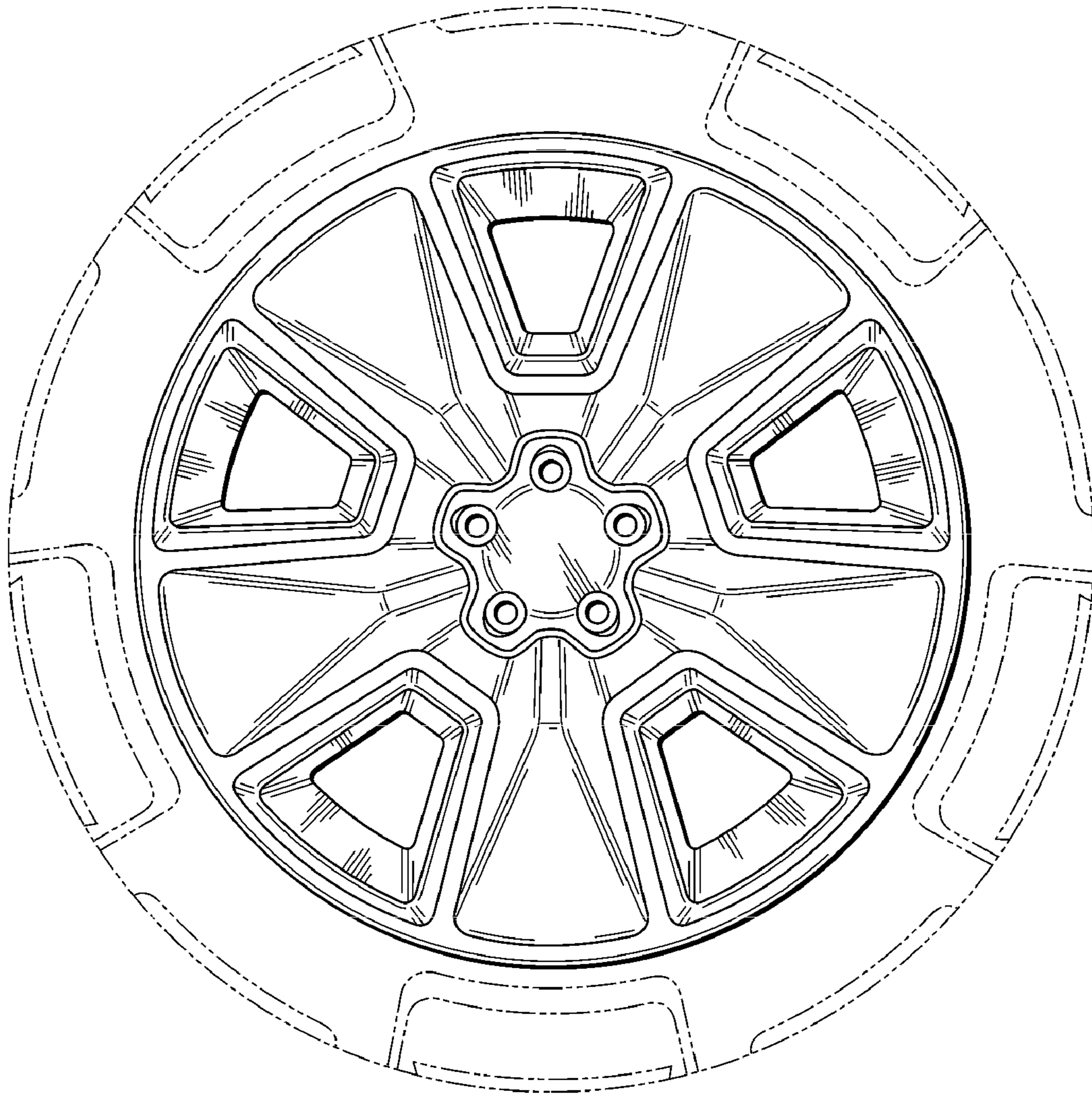

Fig. 1

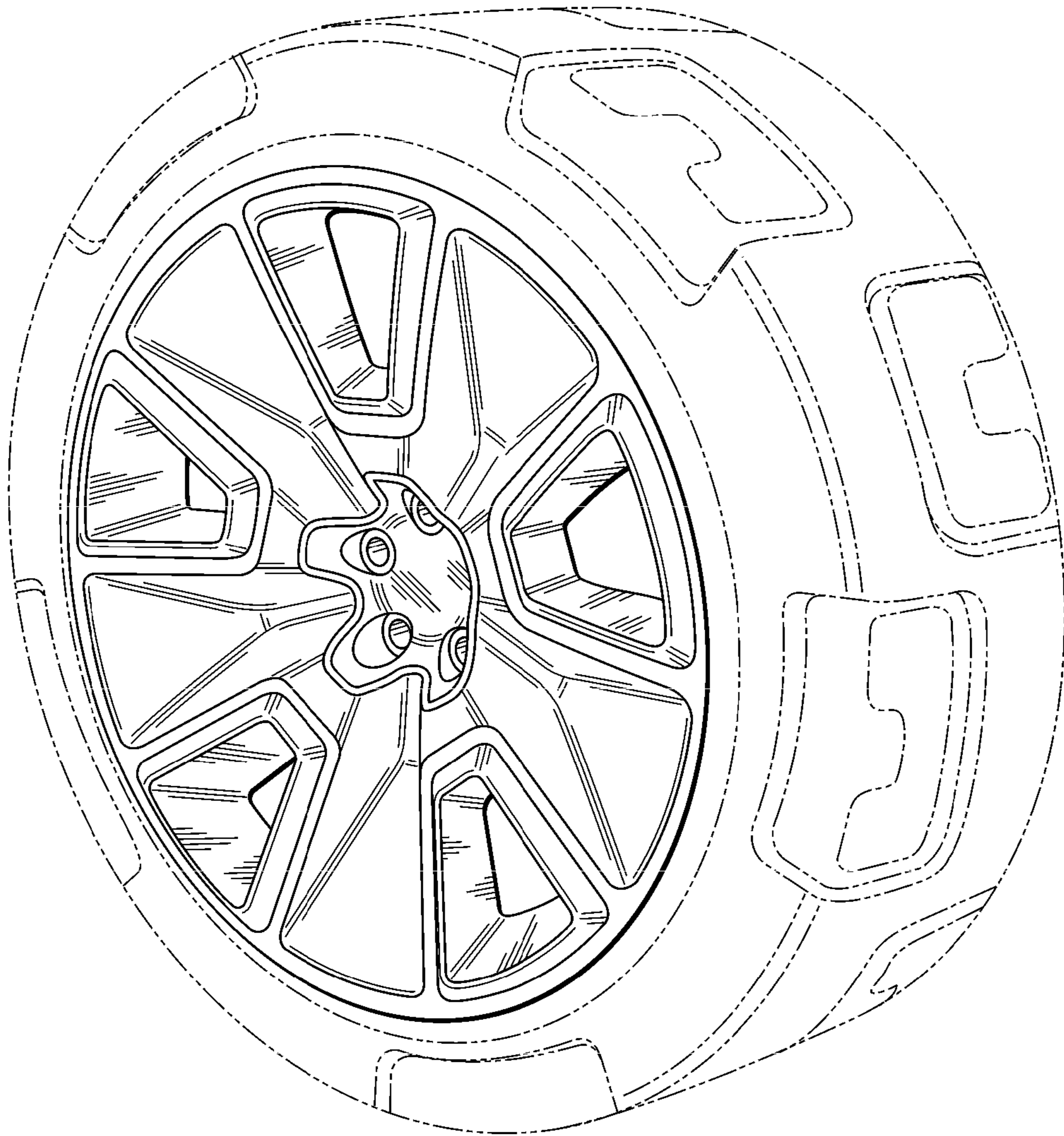

Fig. 2