



US00D621963S

(12) **United States Design Patent**
Zadeh

(10) **Patent No.:** **US D621,963 S**
(45) **Date of Patent:** **** Aug. 17, 2010**

(54) **CHANNEL FOR A METAL FRAMING SYSTEM**

(76) Inventor: **Rahim A. Zadeh**, 5069 Belaire Bluff Ct., Mableton, GA (US) 30126

(**) Term: **14 Years**

(21) Appl. No.: **29/342,183**

(22) Filed: **Aug. 20, 2009**

D479,007 S *	8/2003	Biro	D25/125
6,609,344 B2	8/2003	Saldana		
6,799,407 B2	10/2004	Saldana		
7,021,021 B2	4/2006	Saldana		
7,127,862 B2	10/2006	Saldana		
7,216,465 B2	5/2007	Saldana		
2007/0119843 A1	5/2007	Ball		
2007/0125026 A1	6/2007	Frobosilo		
2007/0193202 A1	8/2007	Rice		
2008/0053035 A1	3/2008	Rosenberg		
2008/0110126 A1	5/2008	Howchin		
2008/0250738 A1	10/2008	Howchin		

Related U.S. Application Data

(63) Continuation of application No. 12/251,029, filed on Oct. 14, 2008.

(51) **LOC (9) Cl.** **25-01**

(52) **U.S. Cl.** **D25/125; D25/121**

(58) **Field of Classification Search** D25/121, D25/125; 52/93.1, 459, 461, 465, 481.1, 52/731.5, 733.2, 344, 460, 462, 468, 579, 52/716.1, 716.8

See application file for complete search history.

* cited by examiner

Primary Examiner—Doris Clark

(74) *Attorney, Agent, or Firm*—Dennis M. Carleton; Fox Rothschild LLP.

(57) **CLAIM**

I claim the ornamental design for a channel for a metal framing system, as shown and described.

DESCRIPTION

FIG. 1 is a perspective view of the channel showing my new design.

FIG. 2 is a left side view thereof.

FIG. 3 is a right side view thereof.

FIG. 4 is a top plan view thereof.

FIG. 5 is a bottom plan view thereof.

FIG. 6 is a left edge view thereof; and,

FIG. 7 is a right edge view thereof.

The broken-line disclosure in the figures illustrates that the channel may be of indeterminate length, and forms no part of the claimed design.

1 Claim, 4 Drawing Sheets

(56) **References Cited**

U.S. PATENT DOCUMENTS

D249,965 S *	10/1978	Cooper	D25/125
4,152,878 A *	5/1979	Balinski	52/481.1
4,918,899 A	4/1990	Karytinis		
5,222,335 A	6/1993	Petrecca		
5,315,804 A	5/1994	Attalla		
5,325,651 A	7/1994	Meyer et al.		
5,412,919 A	5/1995	Pellock et al.		
5,609,006 A	3/1997	Boyer		
5,797,233 A *	8/1998	Hascall	52/481.1
D421,807 S *	3/2000	Reid	D25/125
6,205,740 B1 *	3/2001	Ekerholm et al.	52/846
6,374,558 B1 *	4/2002	Surowiecki	52/241

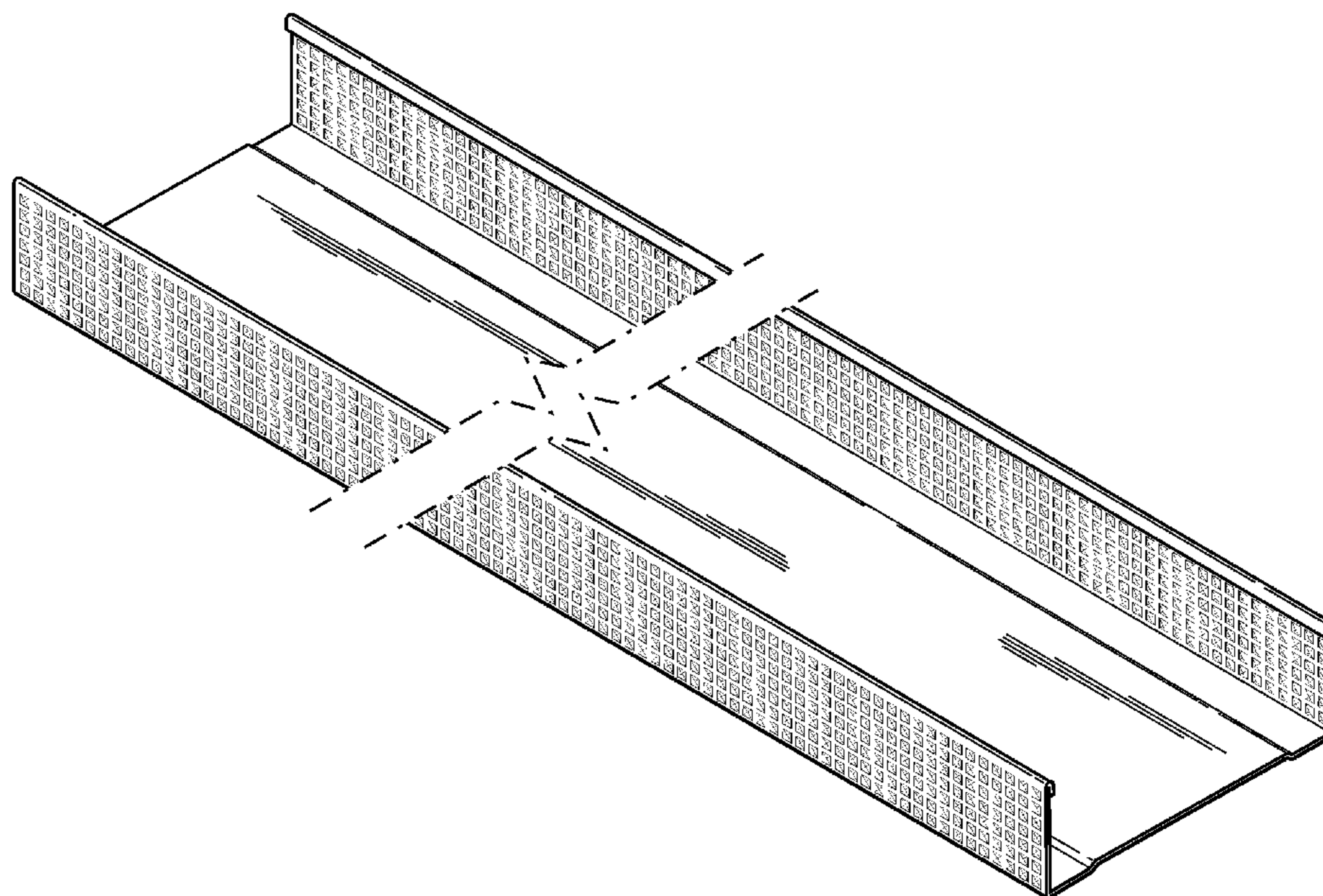

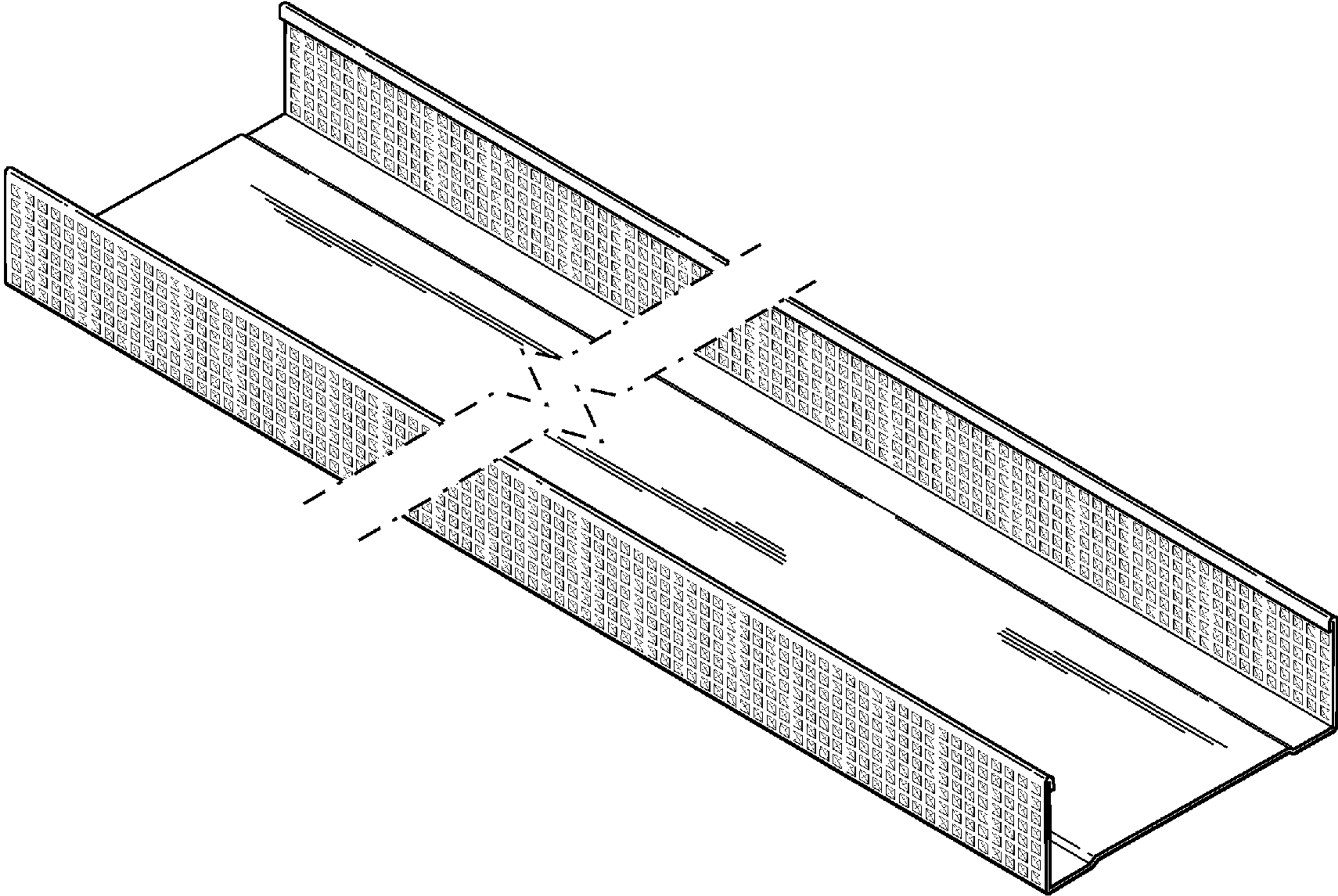

FIG. 1

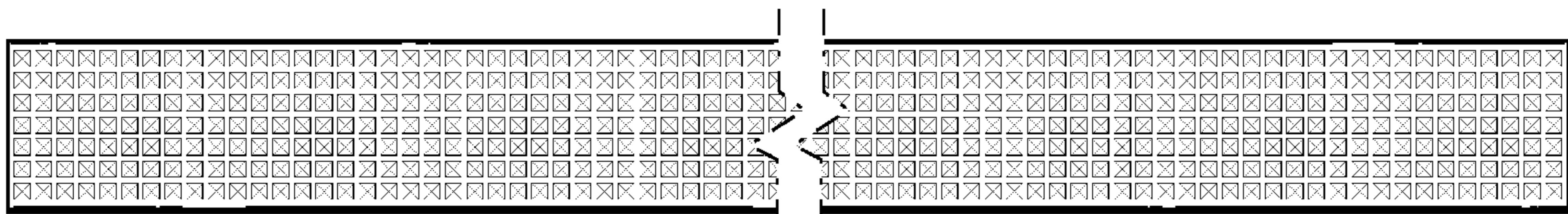

FIG. 2

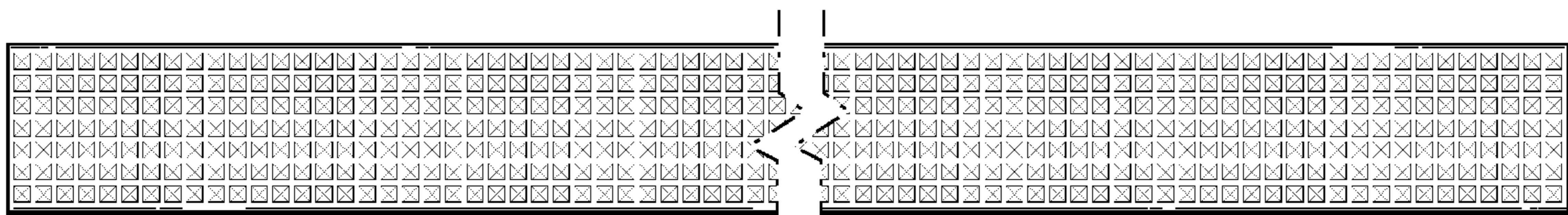

FIG. 3

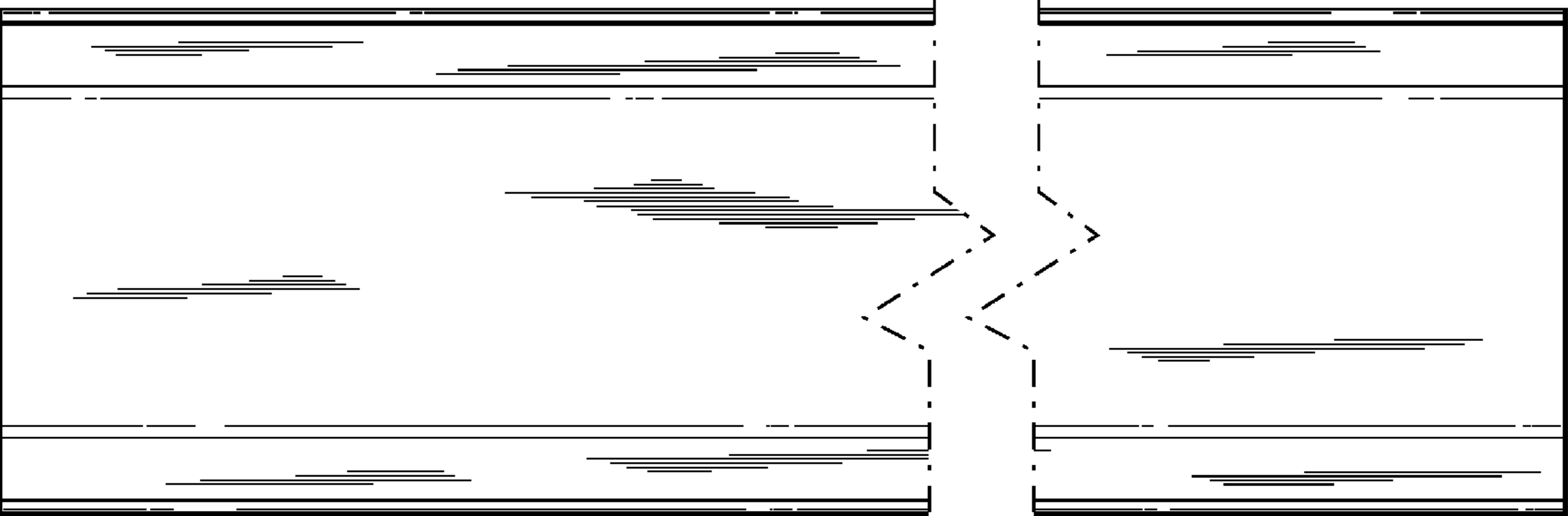

FIG. 4

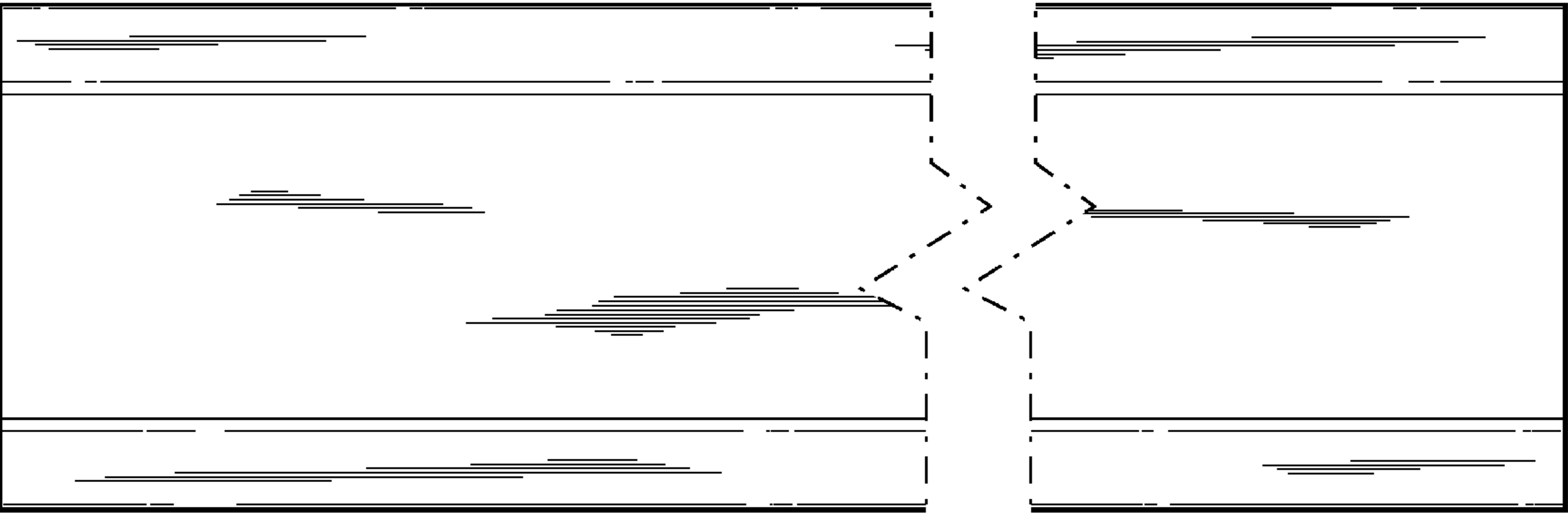

FIG. 5



FIG. 6



FIG. 7