



US00D621780S

(12) **United States Design Patent**
Ferber et al.

(10) **Patent No.:** **US D621,780 S**
(45) **Date of Patent:** **** Aug. 17, 2010**

(54) **TRAVEL CHARGING VALET**

(75) Inventors: **Roman S. Ferber**, West Bloomfield, MI (US); **Hing Wah Tsang**, Ajax (CA)

(73) Assignee: **FKA Distributing Co.**, Commerce Township, MI (US)

(**) Term: **14 Years**

(21) Appl. No.: **29/342,643**

(22) Filed: **Aug. 28, 2009**

(51) **LOC (9) Cl.** **13-02**

(52) **U.S. Cl.** **D13/108; D3/299**

(58) **Field of Classification Search** D13/107–110, D13/118–119, 184, 199; D14/251, 253, D14/432, 434; 320/107–115; D3/201, 273, D3/299, 226, 230, 218, 219; 150/131, 137, 150/152, 154, 165

See application file for complete search history.

(56) **References Cited**

U.S. PATENT DOCUMENTS

D208,252 S *	8/1967	Standard	D12/417
D208,253 S *	8/1967	Standard	D12/417
D316,999 S *	5/1991	Sarff	D3/218
D364,038 S *	11/1995	Stanchin	D3/230
D393,947 S *	5/1998	Alves et al.	D3/303
D473,715 S *	4/2003	Moldovan	D3/299
D485,982 S *	2/2004	Merkel et al.	D3/226
D551,846 S *	10/2007	Ko et al.	D3/201
D570,103 S *	6/2008	Harris et al.	D3/218
D576,790 S *	9/2008	Swan	D3/218
D582,661 S *	12/2008	Katsof	D3/201
D596,842 S *	7/2009	Cooper	D3/205
D612,596 S *	3/2010	Dickenson	D3/226
2009/0184679 A1 *	7/2009	Yeh	320/108

* cited by examiner

Primary Examiner—Rosemary K Tarca

(74) *Attorney, Agent, or Firm*—Brooks Kushman P.C.

(57) **CLAIM**

The ornamental design for a travel charging valet, as shown and described.

DESCRIPTION

FIG. 1 is a perspective view of a travel charging valet incorporating our new design, wherein the travel charging valet is in a first position;

FIG. 2 is a top plan view of the travel charging valet illustrated in FIG. 1;

FIG. 3 is a bottom plan view thereof;

FIG. 4 is a rear elevational view thereof;

FIG. 5 is a front elevational view thereof;

FIG. 6 is a left side elevational view thereof;

FIG. 7 is a right side elevational view thereof;

FIG. 8 is a perspective view of the travel charging valet in a second position;

FIG. 9 is a top plan view of the travel charging valet illustrated in FIG. 8;

FIG. 10 is a bottom plan view thereof;

FIG. 11 is a rear elevational view thereof;

FIG. 12 is a front elevational view thereof;

FIG. 13 is a left side elevational view thereof; and,

FIG. 14 is a right side elevational view thereof.

The ornamental design which is claimed is shown in solid lines in the drawings. Any broken lines in the drawings are for illustrative purposes only and form no part of the claimed design.

1 Claim, 5 Drawing Sheets

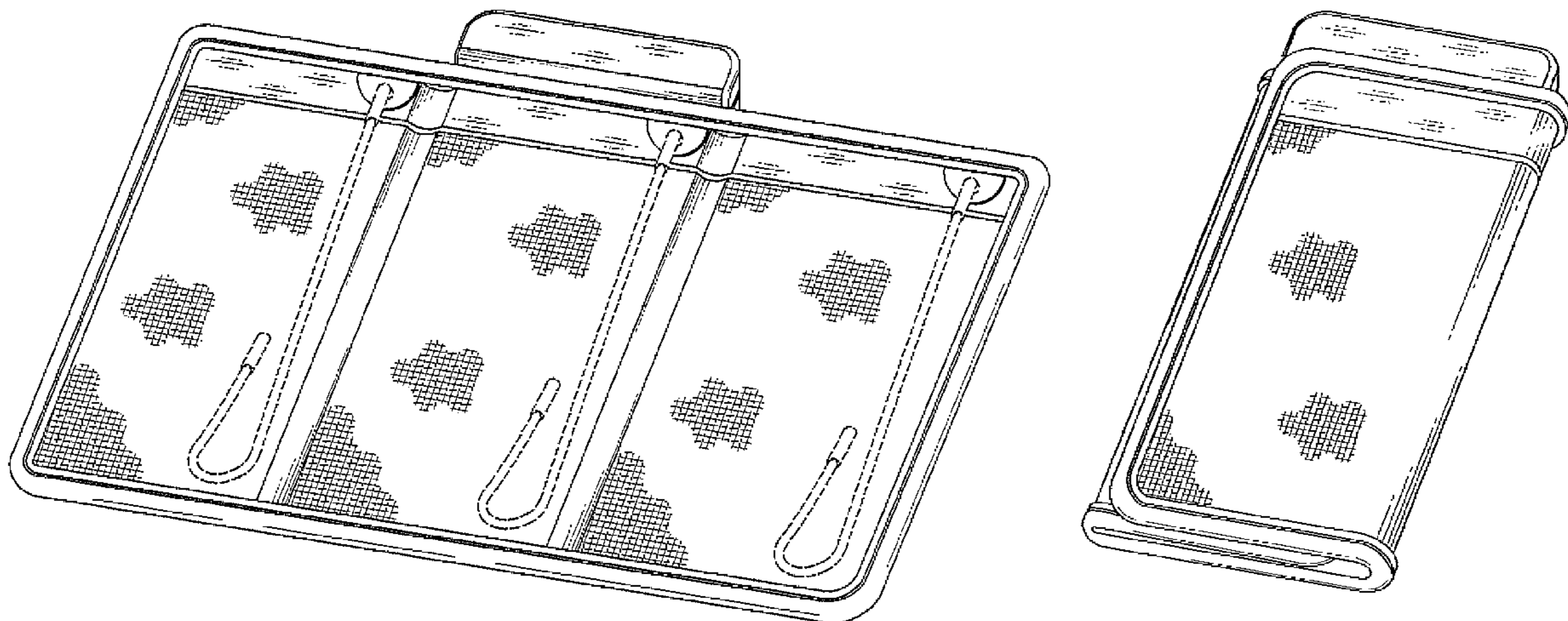
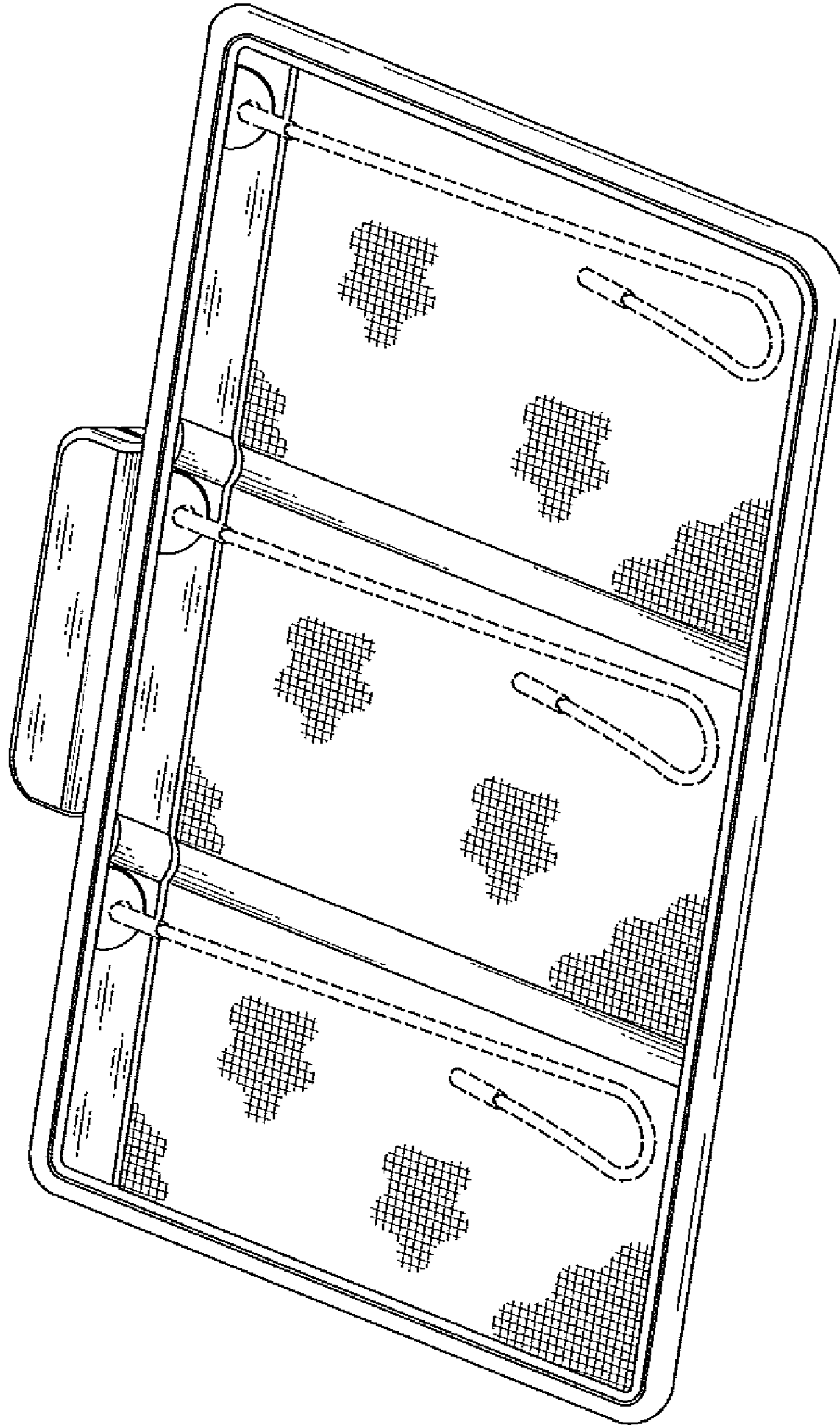

FIG. 1



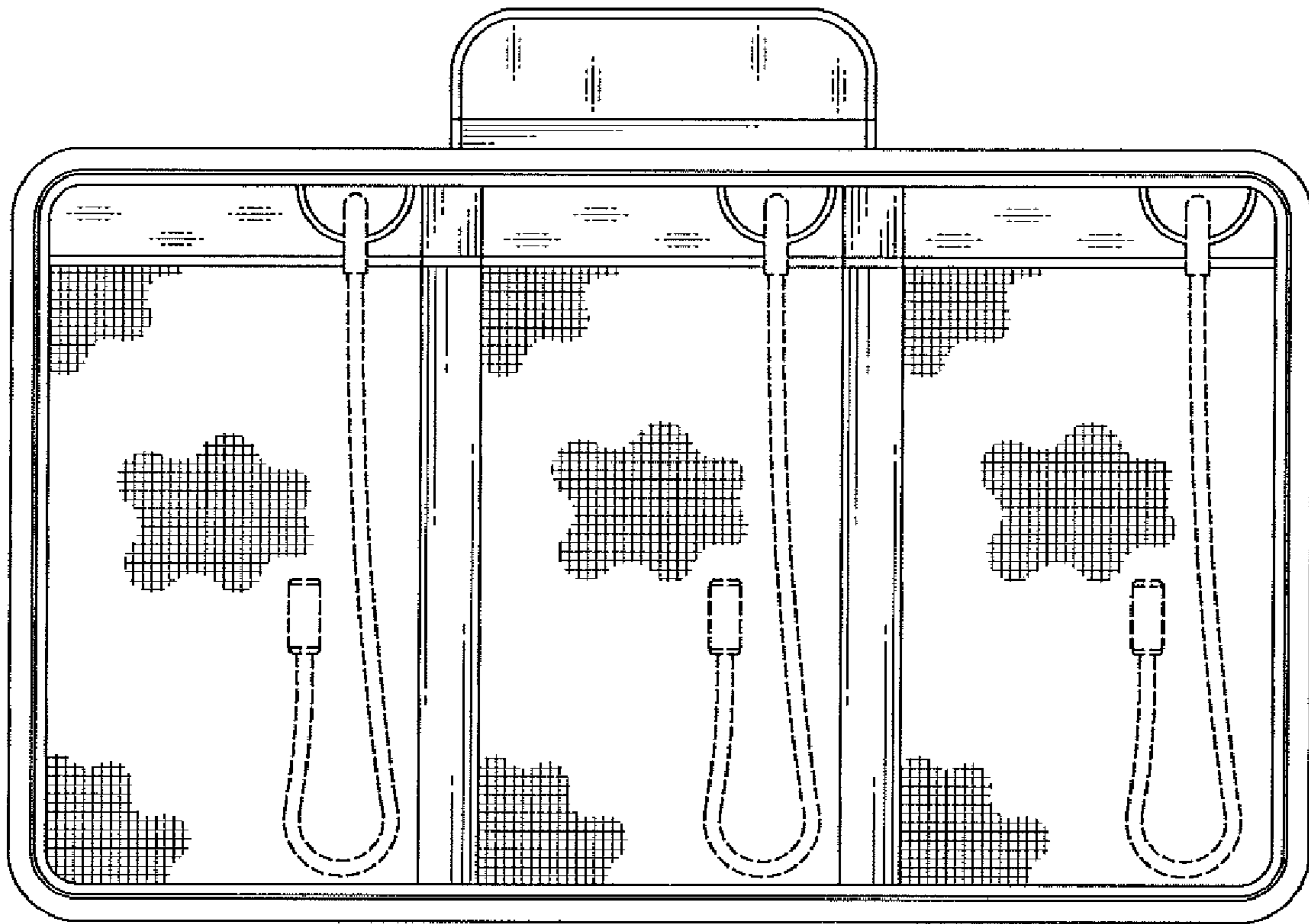

FIG. 2

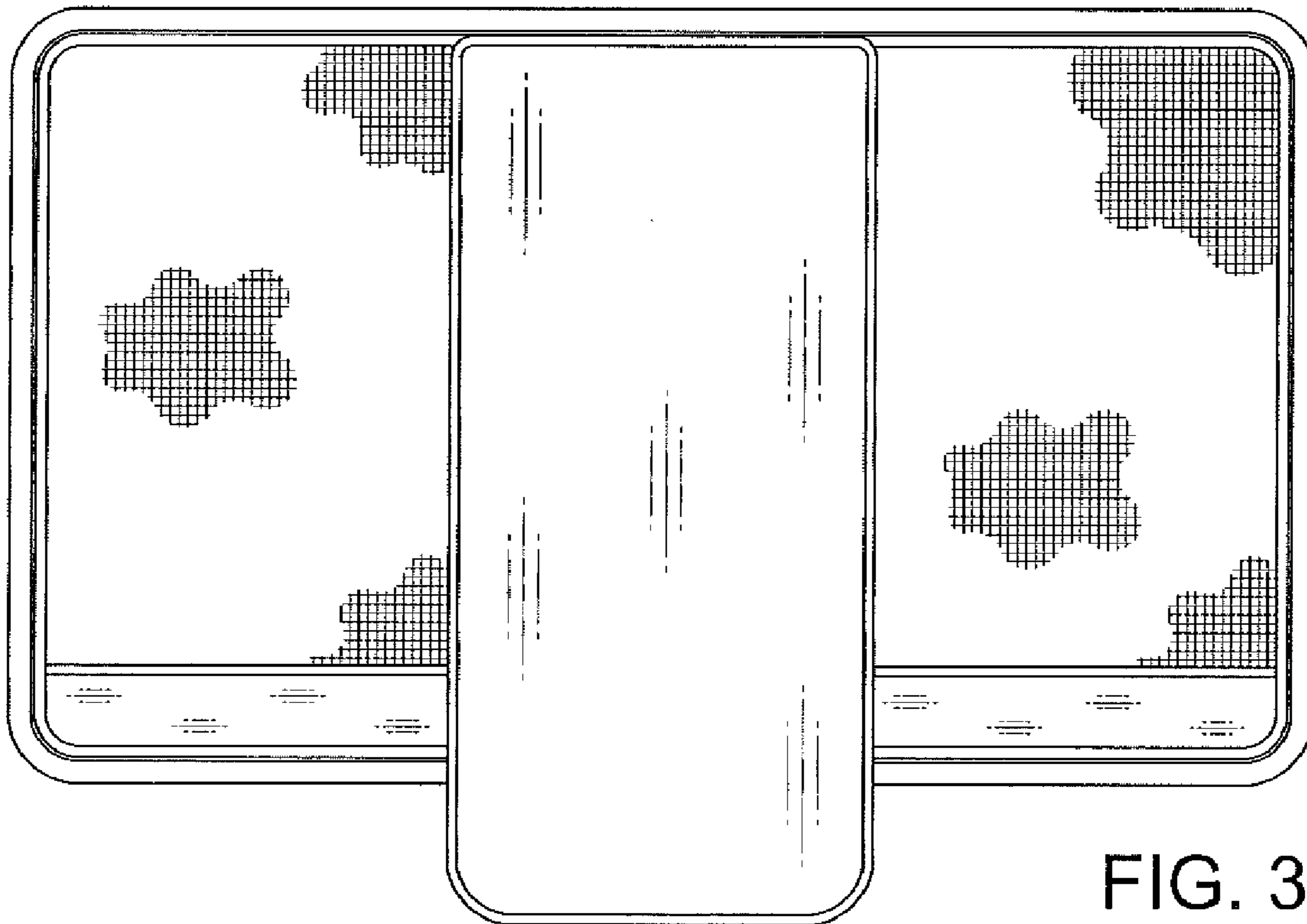

FIG. 3

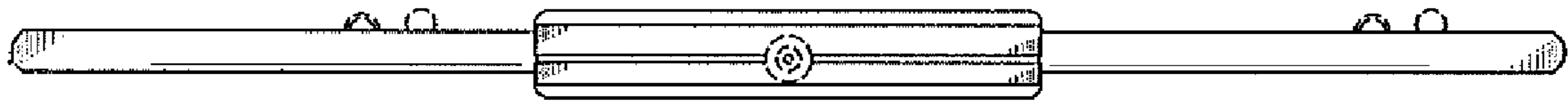

FIG. 4

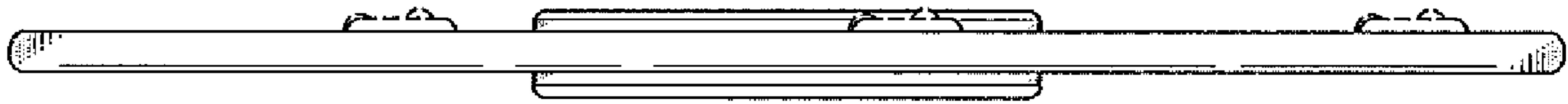

FIG. 5

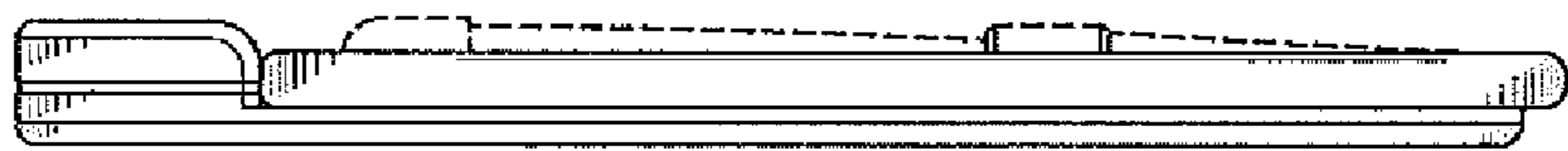

FIG. 6



FIG. 7

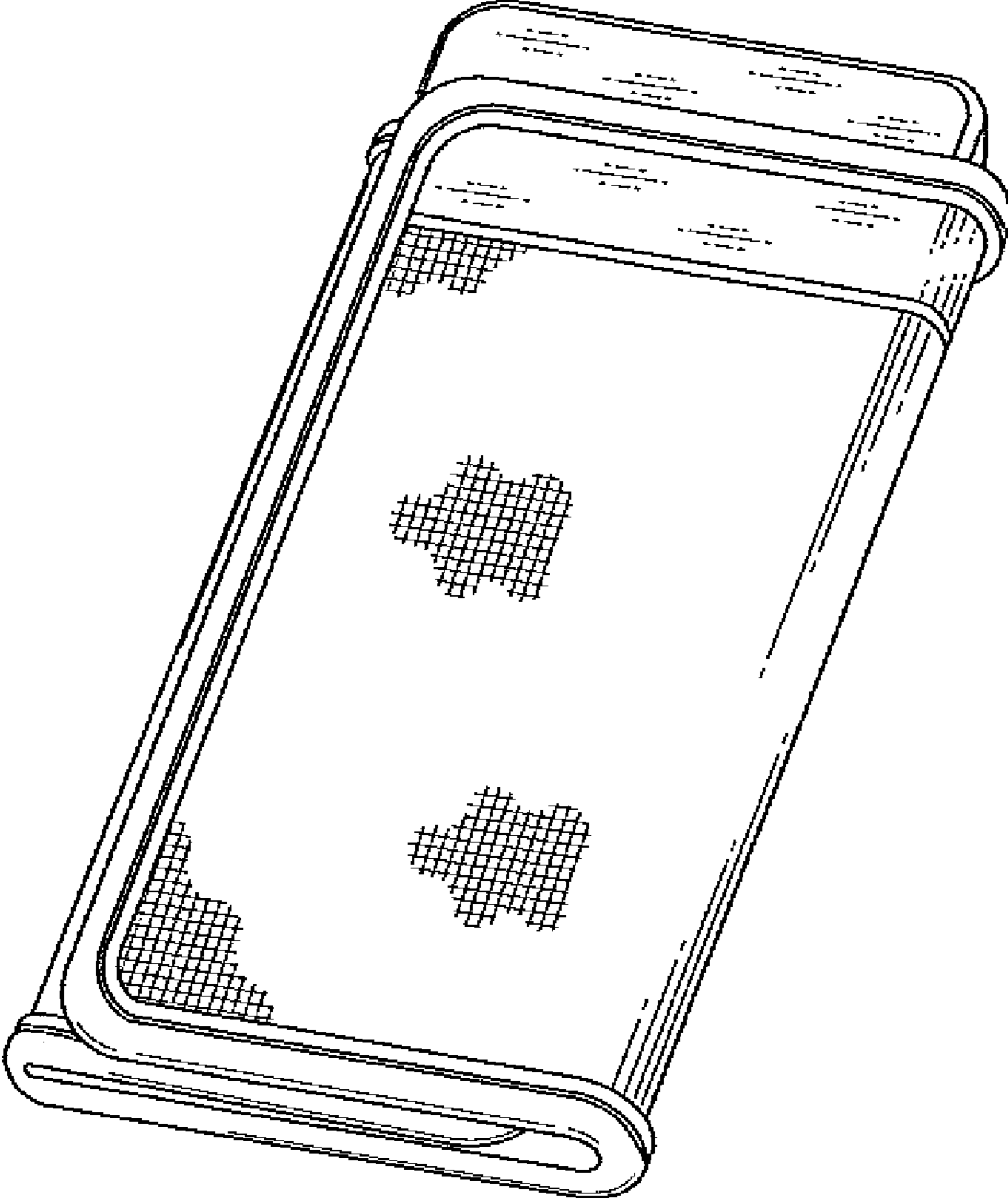

FIG. 8

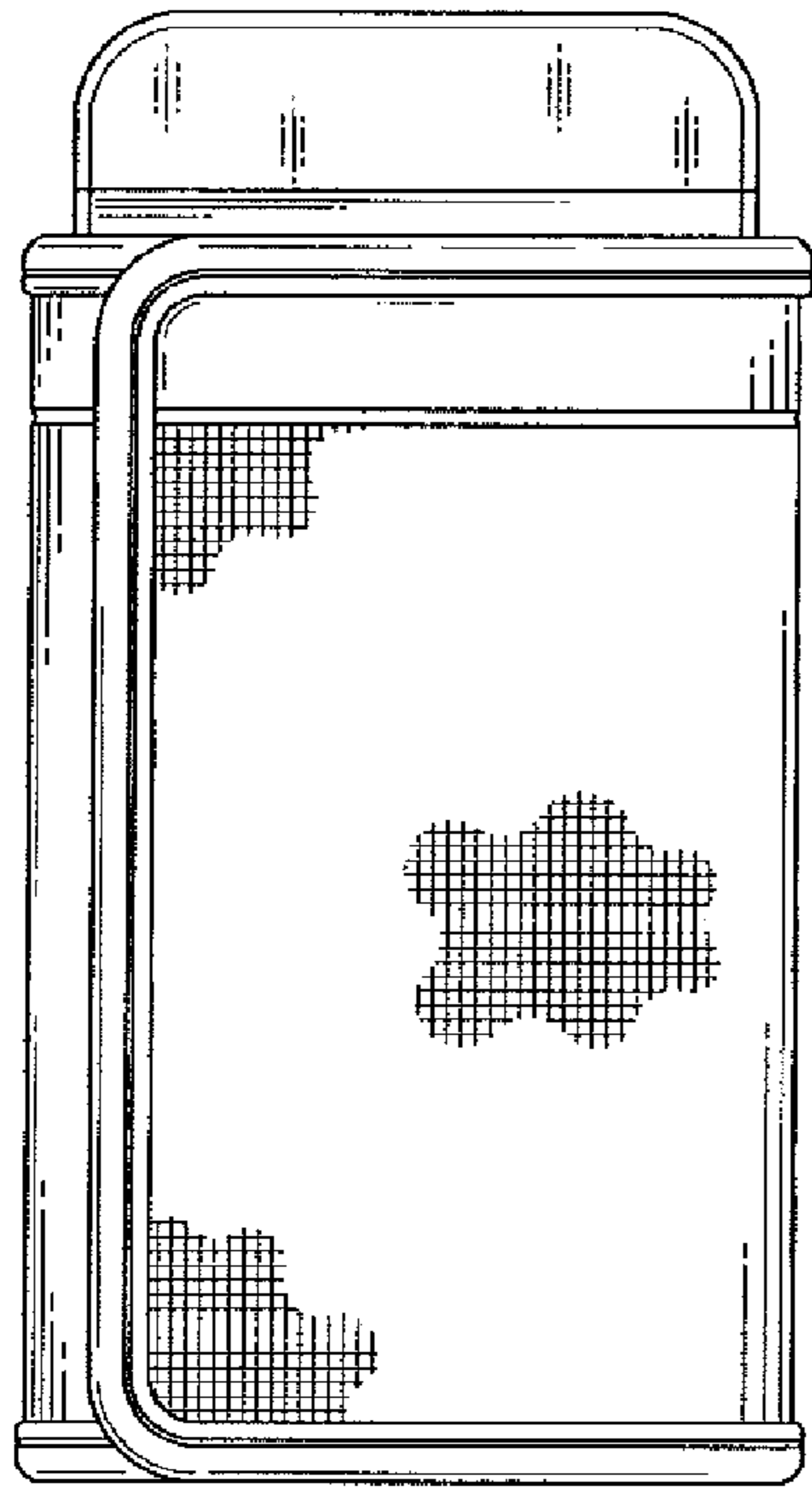

FIG. 9

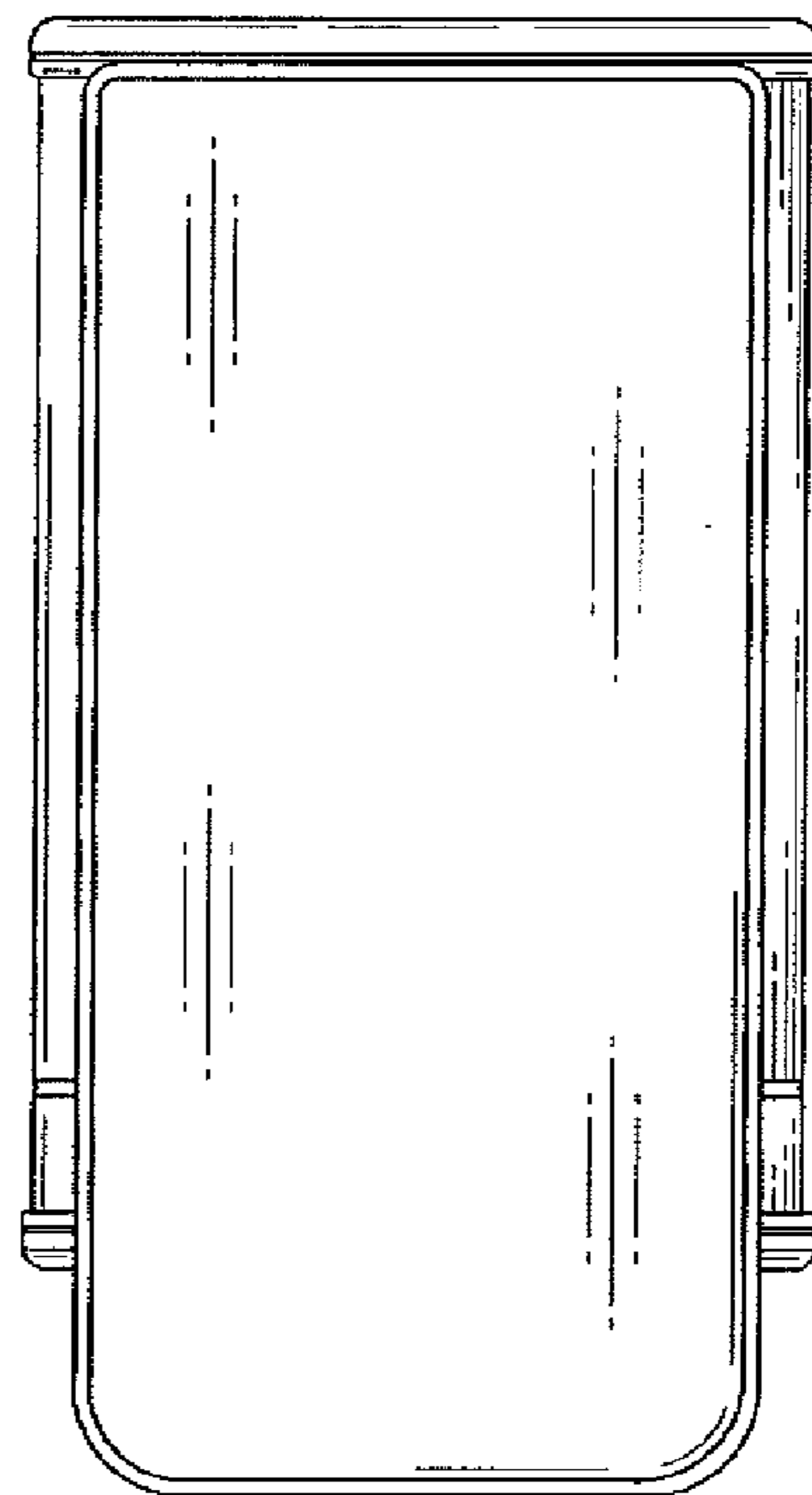

FIG. 10

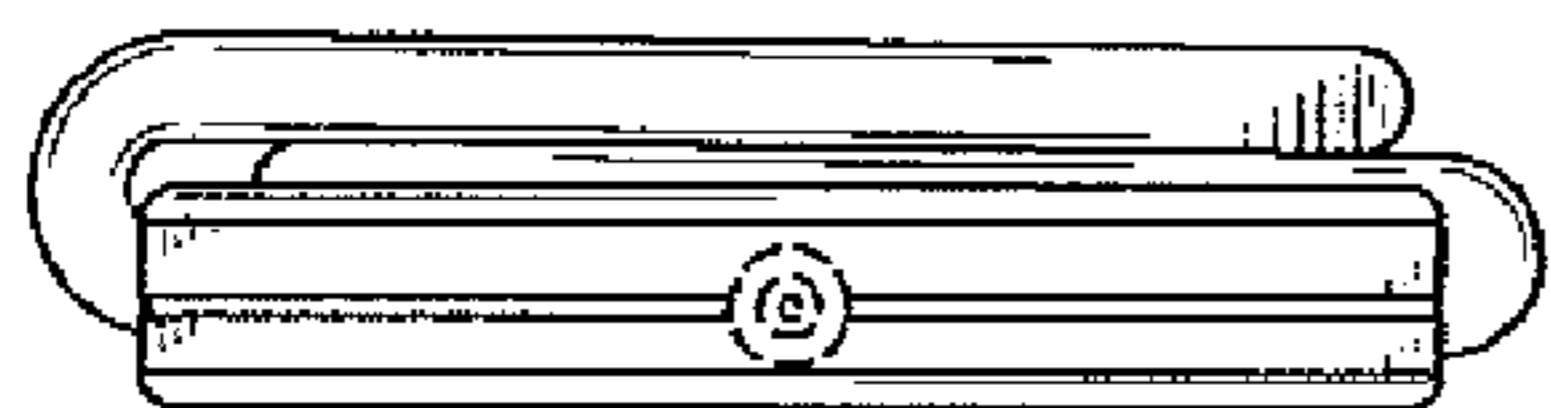

FIG. 11

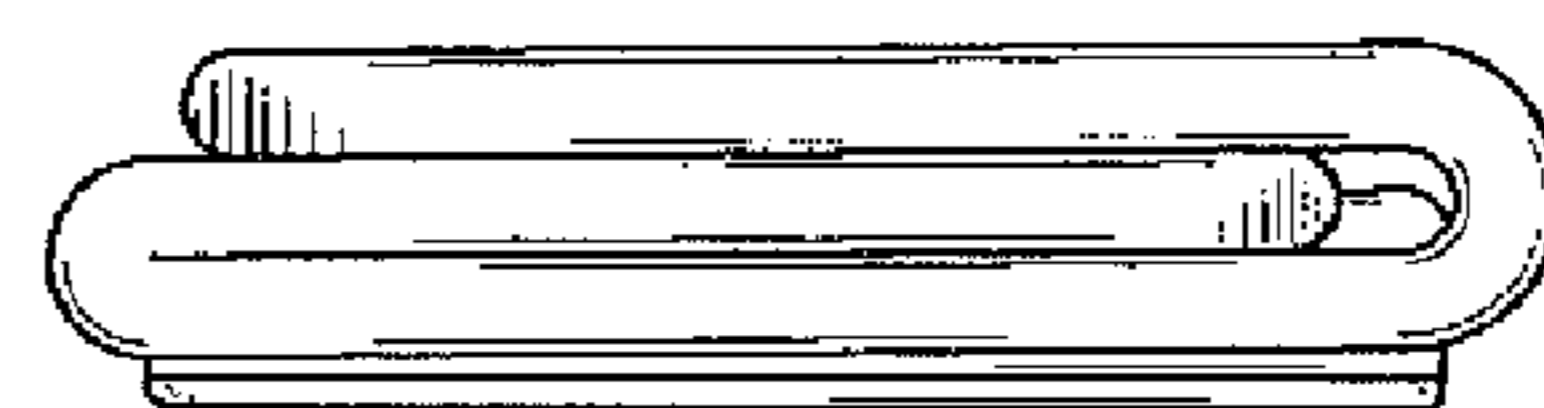

FIG. 12

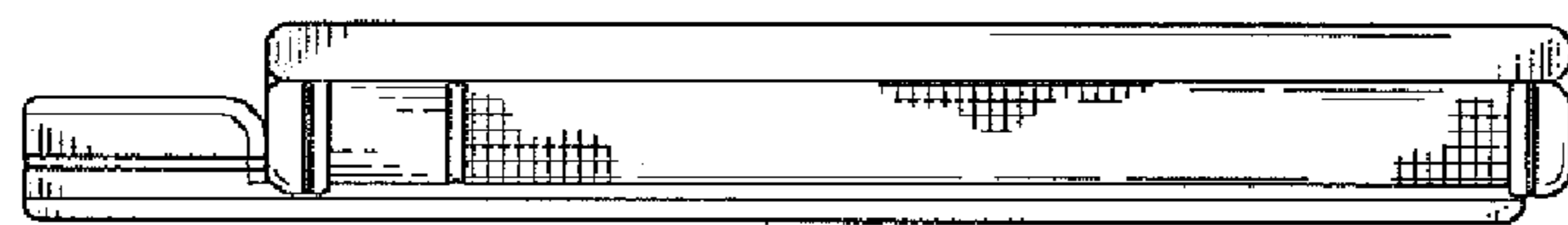

FIG. 13

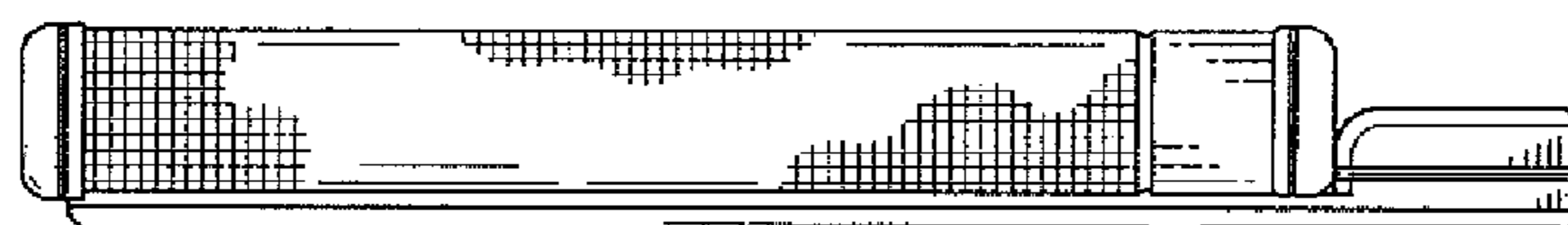

FIG. 14