



US00D621773S

(12) **United States Design Patent**  
**Norman**

(10) **Patent No.:** **US D621,773 S**

(45) **Date of Patent:** **\*\* Aug. 17, 2010**

(54) **MOTORCYCLE STEERING STABILIZER**

(74) *Attorney, Agent, or Firm*—Fehr Law Firm; Thompson E. Fehr

(76) **Inventor:** **Ralph S. Norman**, 8715 Dead Stick Rd., San Diego, CA (US) 92154

(57) **CLAIM**

(\*\*) **Term:** **14 Years**

I claim the ornamental design for a motorcycle steering stabilizer, as shown and described.

(21) **Appl. No.:** **29/288,469**

(22) **Filed:** **Jun. 11, 2007**

**DESCRIPTION**

(51) **LOC (9) Cl.** ..... **12-11**

FIG. 1 is an isometric view from slightly above the motorcycle steering stabilizer, showing a first side and back of the motorcycle steering stabilizer.

(52) **U.S. Cl.** ..... **D12/218**

FIG. 2 is a lateral view of a first side of the motorcycle steering stabilizer.

(58) **Field of Classification Search** ..... D12/110, D12/114, 178, 218, 118, 180, 400, 117; 280/89, 280/90, 270, 272, 274–278, 288.1–288.4, 280/281.1, 833, 835; 74/555.1, 551.2, 551.8; 180/306, 310, 290, 307, 308, 218, 219; 251/209, 251/309, 284, 297

FIG. 3 is a lateral view of a second side of the motorcycle steering stabilizer.

See application file for complete search history.

FIG. 4 is a lateral view of a back of the motorcycle steering stabilizer.

(56) **References Cited**

FIG. 5 is a lateral view of a front of the motorcycle steering stabilizer.

**U.S. PATENT DOCUMENTS**

FIG. 6 is a plan view of the top of the motorcycle steering stabilizer; and,

4,773,514	A *	9/1988	Gustafsson	.....	188/306
4,789,000	A *	12/1988	Aslanian	.....	137/556
5,492,033	A *	2/1996	Hopey	.....	74/551.1
5,516,133	A *	5/1996	Motrenec et al.	.....	280/272
6,401,884	B2 *	6/2002	Norman et al.	.....	188/310
6,726,232	B2 *	4/2004	Hasegawa et al.	.....	280/272
6,802,519	B2 *	10/2004	Morgan et al.	.....	280/272
D571,275	S *	6/2008	Norman	.....	D12/218
7,510,063	B2 *	3/2009	Norman	.....	188/310

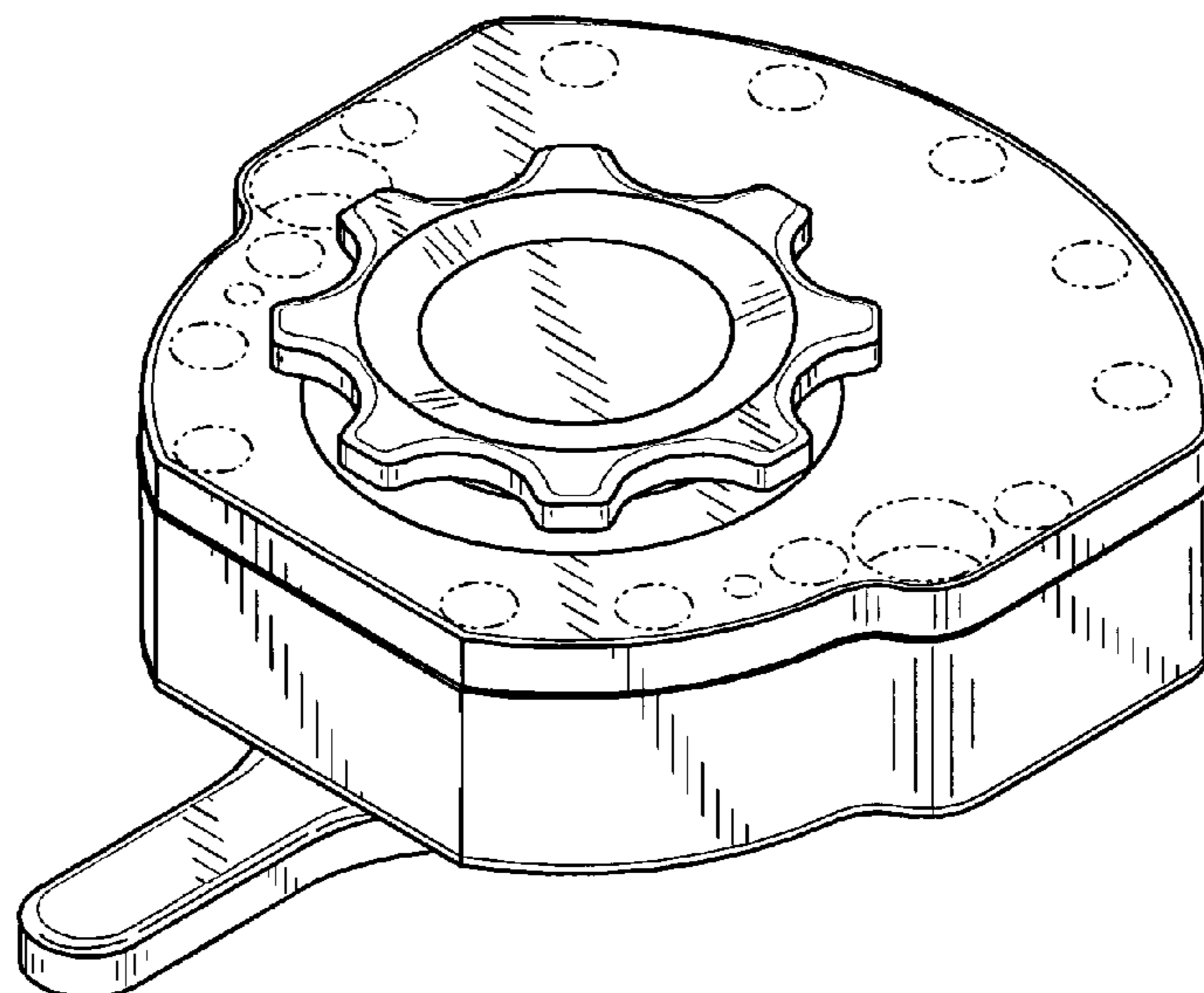
FIG. 7 is a plan view of the bottom of the motorcycle steering stabilizer. The dot-dash lines forming a large circle immediately adjacent the shaded areas represent boundaries between claimed and unclaimed portions of the motorcycle steering stabilizer, and form no part of the claimed design. The smaller dot-dash line circle which is concentric with the dot-dash boundaries represents environmental structure that forms no part of the claimed design.

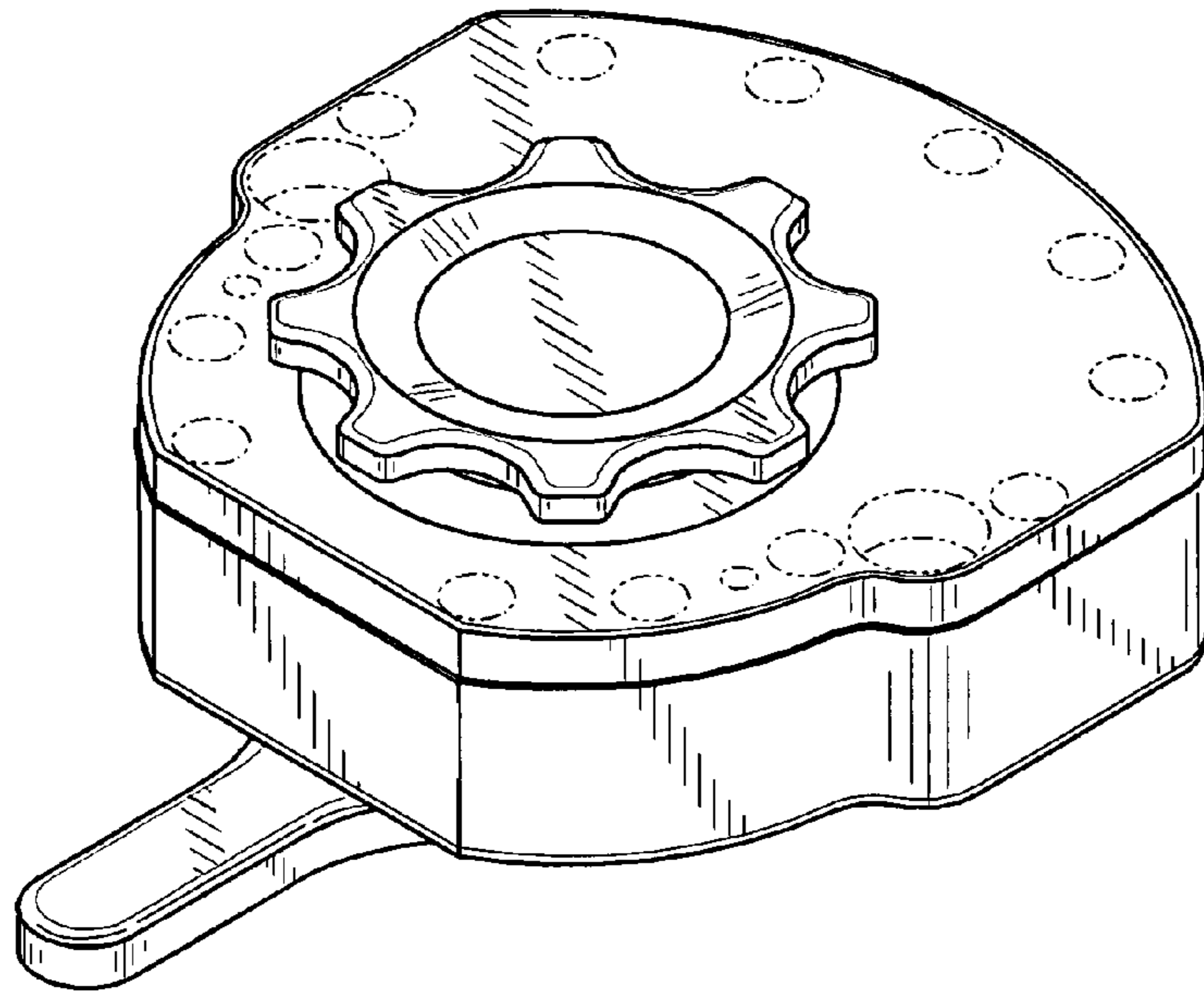
\* cited by examiner

The remaining circles shown in dot-dash lines in FIGS. 1, 6, and 7 represent boundaries of openings that form no part of the claimed design.

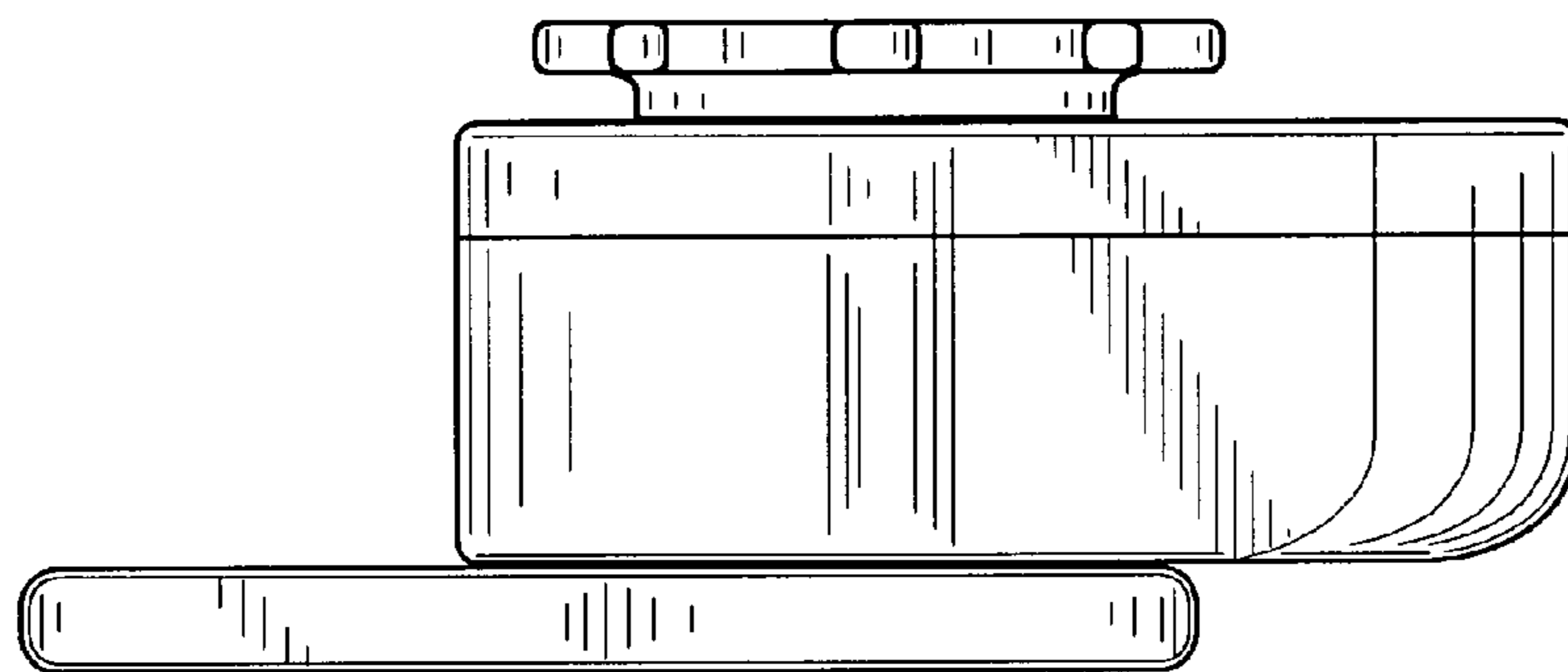
*Primary Examiner*—Philip S Hyder  
*Assistant Examiner*—Linda G. Brooks

**1 Claim, 3 Drawing Sheets**

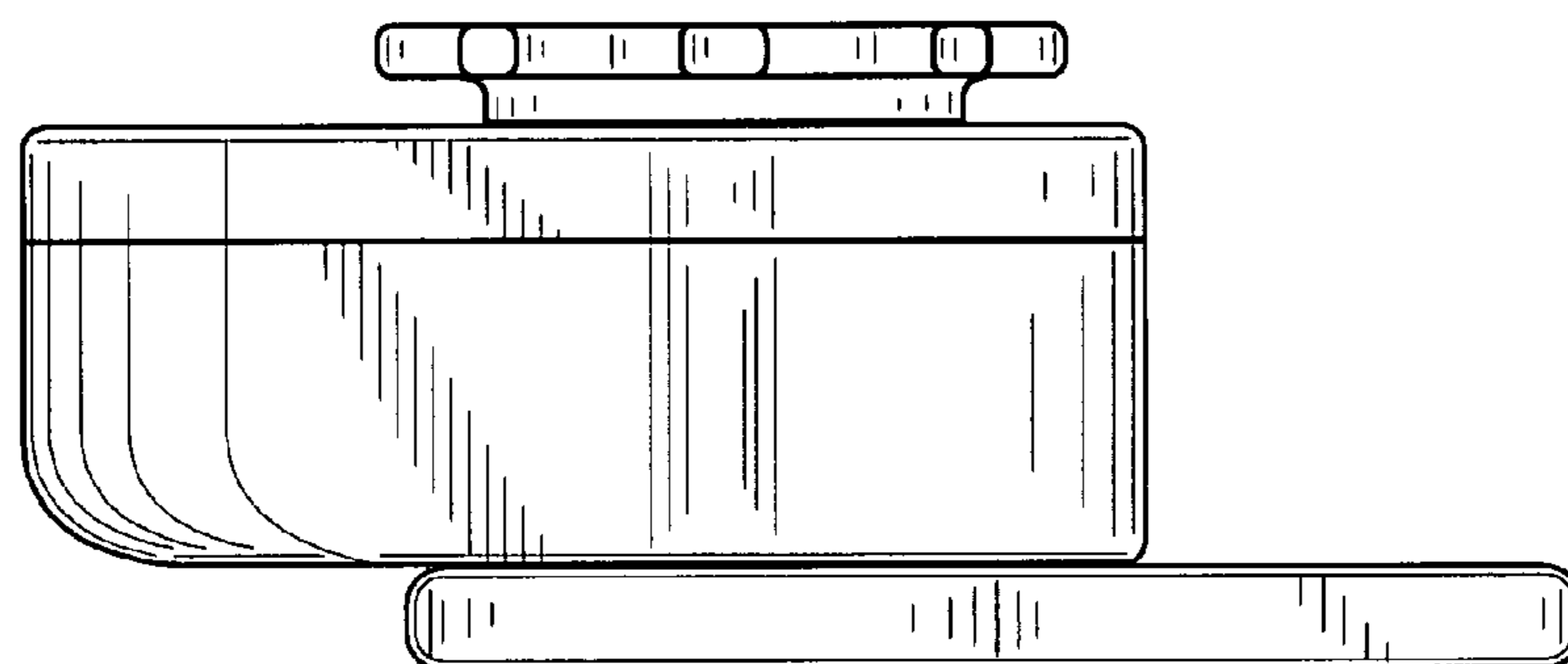




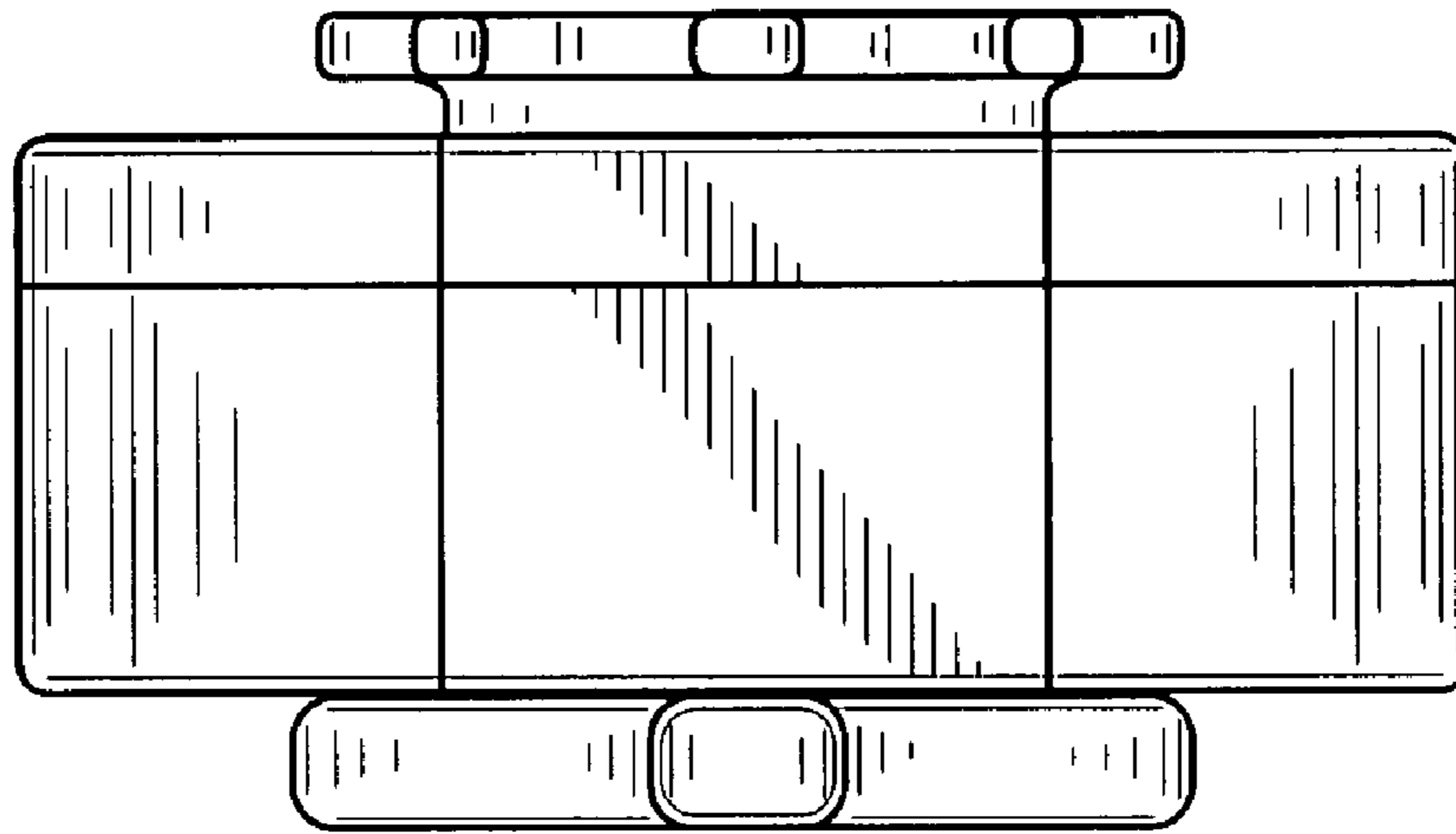
**FIG. 1**



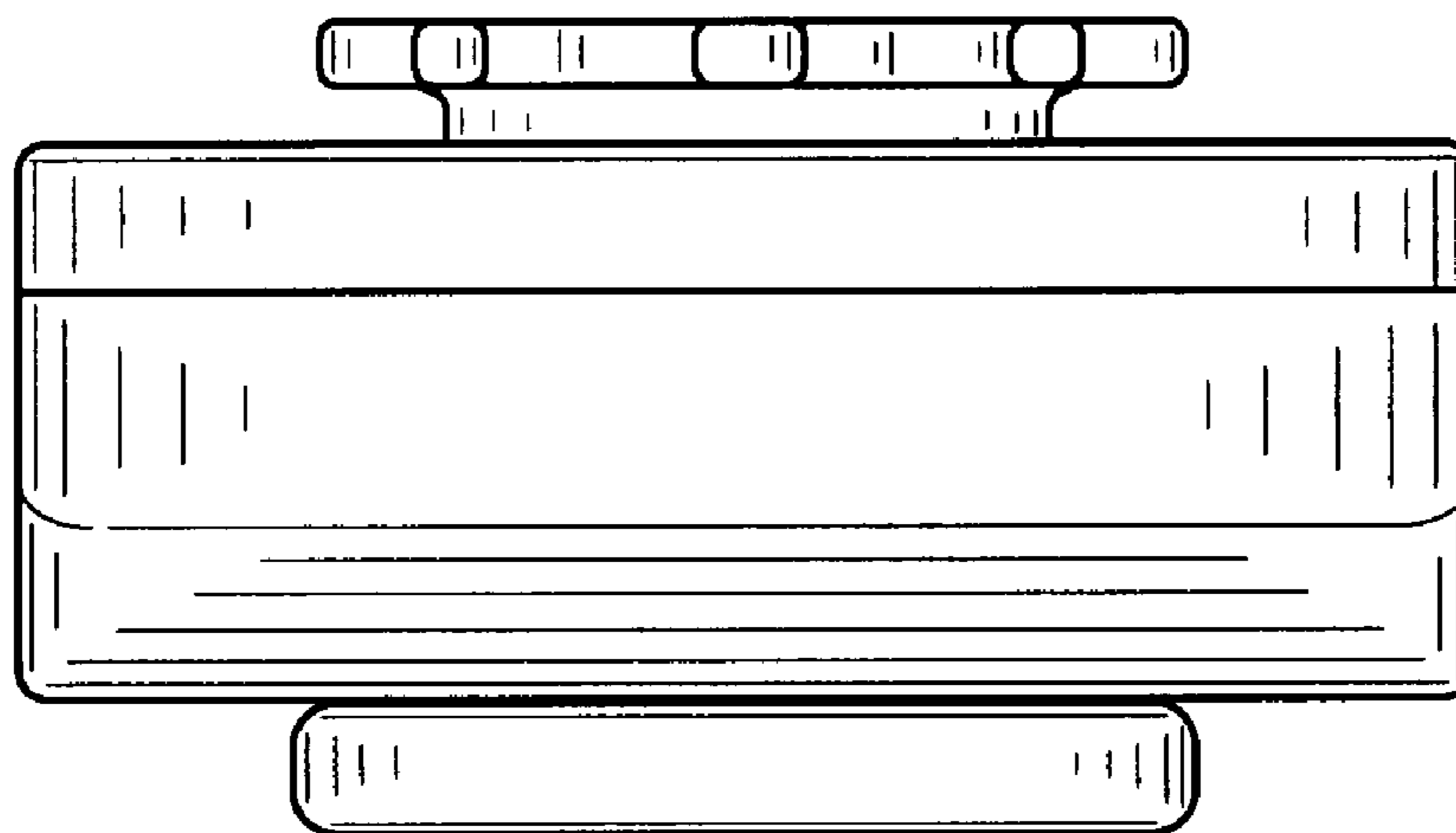
**FIG. 2**



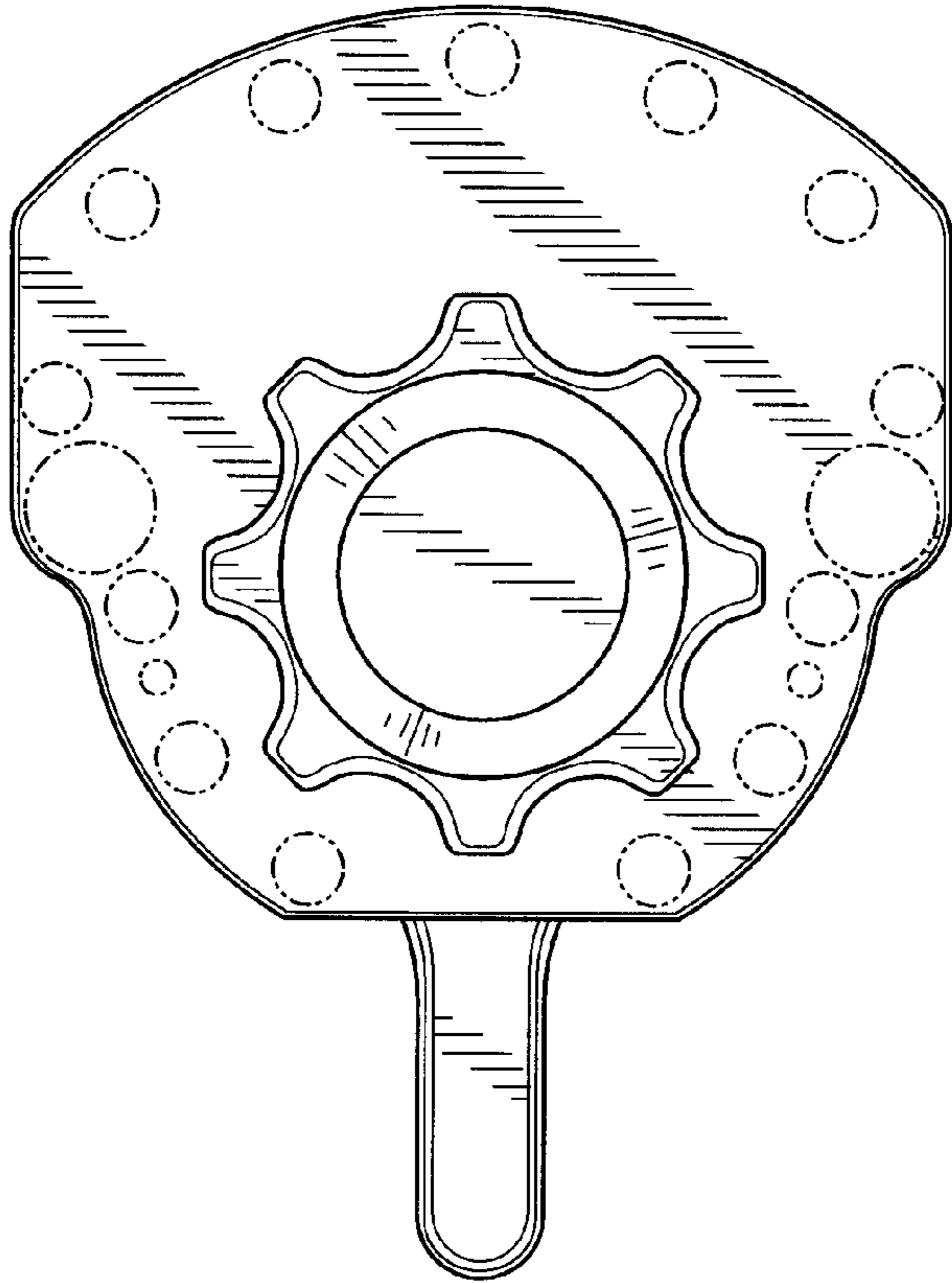
**FIG. 3**



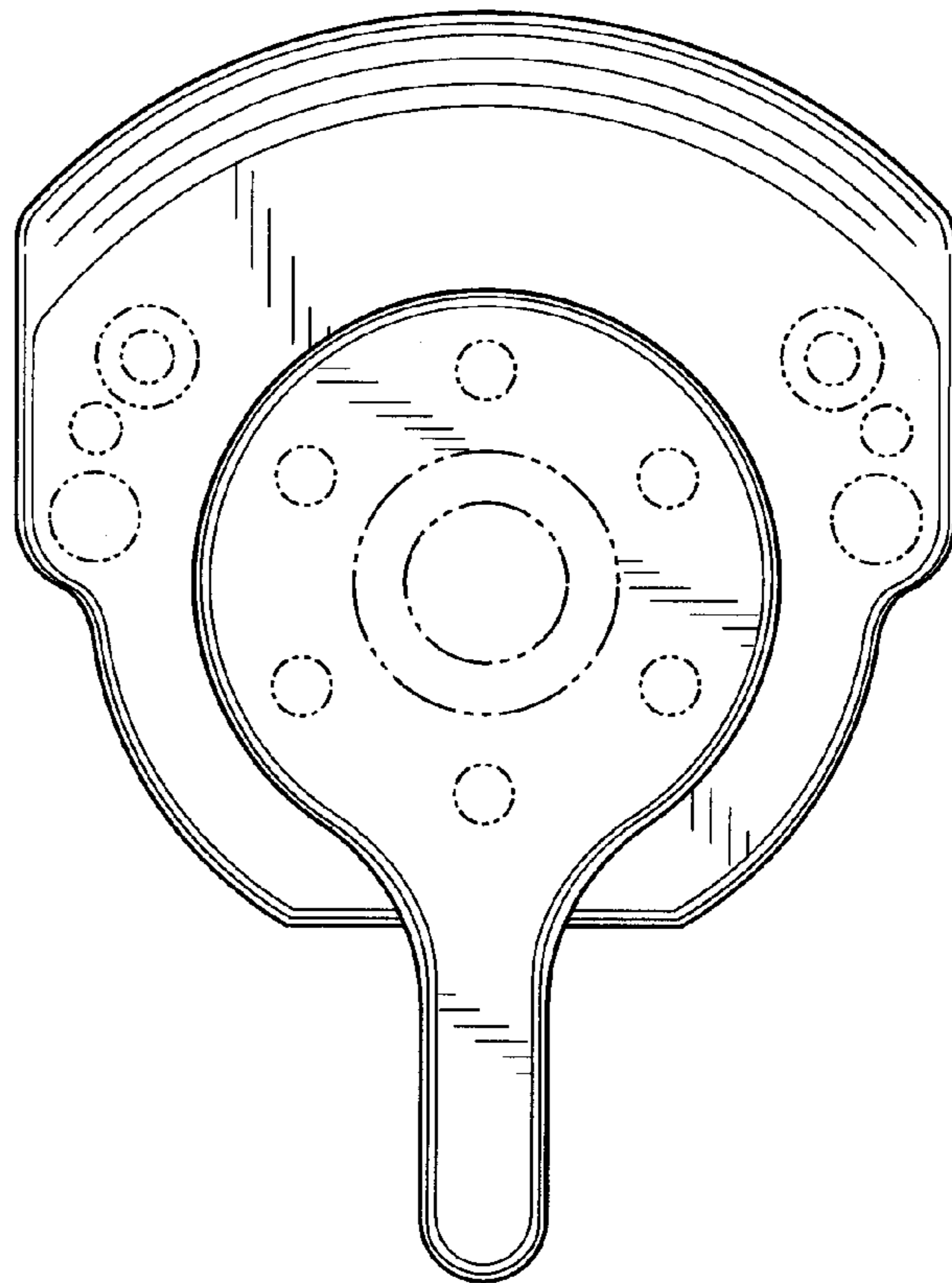
**FIG. 4**



**FIG. 5**



**FIG. 6**



**FIG. 7**