



US00D621331S

(12) **United States Design Patent**
Bock

(10) **Patent No.:** **US D621,331 S**

(45) **Date of Patent:** **** Aug. 10, 2010**

(54) **PARTITION FOR A COMMERCIAL AIRCRAFT PASSENGER CABIN**

(75) Inventor: **Thomas-Mathias Bock**, Grenade sur Garonne (FR)

(73) Assignee: **Airbus SAS**, Blagnac Cedex (FR)

(**) Term: **14 Years**

(21) Appl. No.: **29/250,818**

(22) Filed: **Dec. 1, 2006**

(51) **LOC (9) Cl.** **12-07**

(52) **U.S. Cl.** **D12/345**

(58) **Field of Classification Search** D12/345,
D12/106, 20, 42, 43, 317, 319, 356, 195,
D12/196; D6/349, 350, 355, 492, 332, 356,
D6/511; 297/118; 244/118.1, 118.2, 118.5,
244/118.6, 119, 120, 121, 122 R

See application file for complete search history.

(56) **References Cited**

U.S. PATENT DOCUMENTS

- 265,863 A * 10/1882 Quiggle 40/310
- D27,692 S * 9/1897 Eames D12/196
- D177,678 S * 5/1956 Hvidt et al. D6/511
- D191,306 S * 9/1961 Grosskopf D6/349
- 3,178,747 A * 4/1965 Peterson 15/236.01
- 3,516,106 A * 6/1970 Roefaro 15/236.05
- 3,801,152 A * 4/1974 Tims et al. 296/78.1
- 4,004,388 A * 1/1977 Stefanik 52/204.593
- D246,303 S * 11/1977 Davis D12/195
- D248,912 S * 8/1978 Canfield et al. D6/421
- D249,609 S * 9/1978 Kramer D6/421
- D257,601 S * 12/1980 Cyplik D6/332
- D257,604 S * 12/1980 Cyplik D6/332

(Continued)

OTHER PUBLICATIONS

U.S. Appl. No. 29/250,809. Title: Partition for a Commercial Aircraft Passenger Cabin, filed Dec. 1, 2006.

(Continued)

Primary Examiner—Cathron C Brooks

Assistant Examiner—Kevin K Rudzinski

(74) *Attorney, Agent, or Firm*—Osler, Hoskin & Harcourt LLP

(57) **CLAIM**

The ornamental design for a partition for a commercial aircraft passenger cabin, as shown and described.

DESCRIPTION

FIG. 1 is a rear, left perspective view of a partition for a commercial aircraft passenger cabin according to my design;

FIG. 2 is a top plan view thereof;

FIG. 3 is a left side elevation view thereof;

FIG. 4 is a right side elevation view thereof;

FIG. 5 is a rear elevation view thereof;

FIG. 6 is a front elevation view thereof;

FIG. 7 is a rear, left perspective view of the partition of FIG. 1 shown with a commercial aircraft passenger cabin seat and ottoman;

FIG. 8 is a top plan view of the partition, seat and ottoman shown in FIG. 7;

FIG. 9 is a front, left perspective view of the partition of FIG. 1 shown in a commercial aircraft passenger cabin; and,

FIG. 10 is a top plan view of the partition and cabin shown in FIG. 9.

No bottom plan view is included as no features of the claimed design are visible therein.

Throughout the Figures, the broken lines on the partition represent the unclaimed boundaries of the claimed design, with the shaded areas being part of the claimed design and the non-shaded areas forming no part of the claimed design. The broken lines showing environment are for illustrative purposes only and form no part of the claimed design.

A mirror image of the partition shown in the drawings is within the scope of the claimed design.

1 Claim, 9 Drawing Sheets

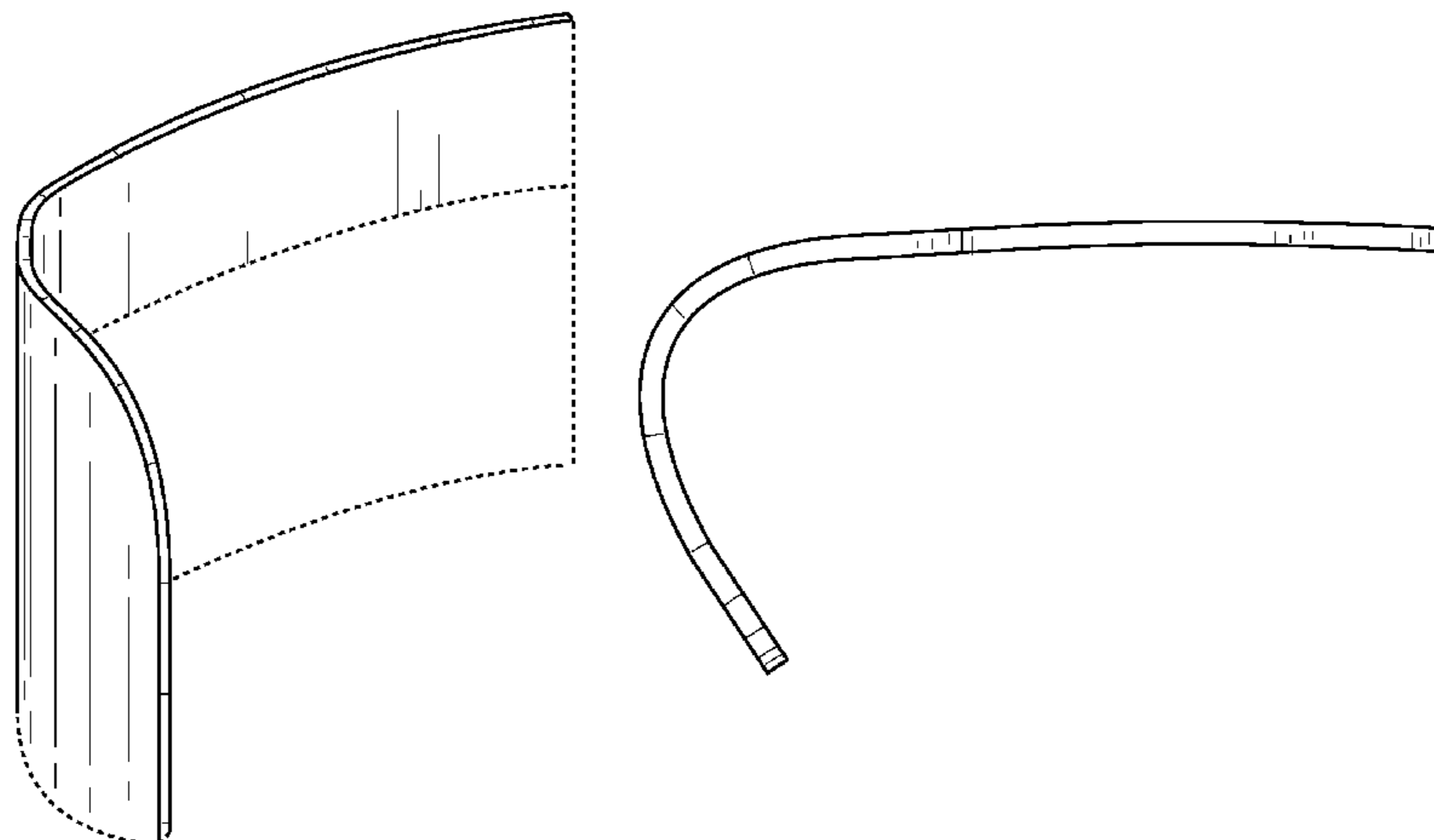

U.S. PATENT DOCUMENTS

D257,812 S * 1/1981 Cyplik D6/332
 4,284,677 A * 8/1981 Herliczek 428/192
 4,666,799 A * 5/1987 Runquist et al. 429/101
 D304,529 S * 11/1989 Hontz D6/421
 4,984,838 A * 1/1991 Kim 296/75
 5,054,885 A * 10/1991 Melby 359/618
 D330,638 S * 11/1992 Moschini D6/334
 D349,608 S * 8/1994 Savoie D6/332
 D359,988 S * 7/1995 Lechleiter et al. D20/10
 D363,582 S * 10/1995 Siler D32/74
 D368,344 S * 3/1996 Hansen D32/46
 5,522,191 A * 6/1996 Wenner et al. 52/204.51
 D382,735 S * 8/1997 Zapf D6/492
 D389,680 S * 1/1998 Moore D6/511
 D403,904 S * 1/1999 Machael et al. D6/511
 5,857,727 A * 1/1999 Vetter 296/78.1
 D407,011 S * 3/1999 Boije D8/381
 D412,625 S * 8/1999 Montague et al. D6/421
 5,997,139 A * 12/1999 Yasuda 351/49
 D421,948 S * 3/2000 Dryburgh et al. D12/195
 D427,783 S * 7/2000 Luedke D6/332
 D436,469 S * 1/2001 Idaszak et al. D6/480
 D439,063 S * 3/2001 Round et al. D6/356
 D439,425 S * 3/2001 Park et al. D6/356
 6,209,956 B1 * 4/2001 Dryburgh et al. 297/245
 D449,169 S * 10/2001 Bennie et al. D6/332
 D452,559 S * 12/2001 Schonberger et al. D23/406
 D452,786 S * 1/2002 Petri D6/511
 6,347,590 B1 * 2/2002 D'Annunzio et al. 108/44
 D456,338 S * 4/2002 Granzeier et al. D12/345
 D457,359 S * 5/2002 Chan D6/492
 D458,041 S * 6/2002 Couture et al. D6/332
 6,502,905 B2 * 1/2003 Cheris et al. 297/423.46
 6,505,877 B1 * 1/2003 Devlin et al. 296/78.1
 D472,400 S * 4/2003 Pomodoro D6/426
 D473,410 S * 4/2003 Verbeek D6/511
 D479,184 S * 9/2003 Roseman D12/345
 6,613,258 B1 * 9/2003 Maison et al. 264/102
 D483,971 S * 12/2003 Barlow-Lawson D6/511
 D484,450 S * 12/2003 Davidson et al. D12/317
 6,669,141 B2 * 12/2003 Schmidt-Schaeffer 244/118.6

D490,103 S * 5/2004 Rangel et al. D19/10
 D492,503 S * 7/2004 Gower D6/421
 D510,816 S * 10/2005 Lee D6/356
 D513,564 S * 1/2006 Nobles et al. D6/332
 D524,695 S * 7/2006 Manchik D12/106
 D525,794 S * 8/2006 Ball et al. D6/332
 D540,565 S * 4/2007 Nakamura D6/421
 D558,993 S * 1/2008 Saint-Jalmes et al. D6/357
 D564,764 S * 3/2008 Springer et al. D6/332
 2002/0017810 A1 * 2/2002 Dryburgh et al. 297/354.13
 2005/0073172 A1 * 4/2005 Weinert et al. 296/146.16
 2006/0170261 A1 * 8/2006 Baatz et al. 297/245
 2008/0093502 A1 * 4/2008 Bettell 244/118.5
 2008/0100093 A1 * 5/2008 Seiple et al. 296/146.16

OTHER PUBLICATIONS

U.S. Appl. No. 29/250,814. Title:Partition for a Commercial Aircraft Passenger Cabin, filed Dec. 1, 2006.
 U.S. Appl. No. 29/250,828. Title:Partition for a Commercial Aircraft Passenger Cabin, filed Dec. 1, 2006.
 U.S. Appl. No. 29/250,831. Title:Seat Body for a Commercial Aircraft Passenger Cabin, filed Dec. 1, 2006.
 U.S. Appl. No. 29/250,826. Title:Seat Layout for a Commercial Aircraft Passenger Cabin, filed Dec. 1, 2006.
 U.S. Appl. No. 29/250,825. Title:Partition Layout for a Commercial Aircraft Passenger Cabin, filed Dec. 1, 2006.
 U.S. Appl. No. 29/250,833. Title:Partition Layout for a Commercial Aircraft Passenger Cabin, filed Dec. 1, 2006.
 U.S. Appl. No. 29/250,834. Title:Partition Layout for a Commercial Aircraft Passenger Cabin, filed Dec. 1, 2006.
 U.S. Appl. No. 29/250,832. Title:Ottoman for a Commercial Aircraft Passenger Cabin, filed Dec. 1, 2006.
 U.S. Appl. No. 29/250,811. Title:Seat for a Commercial Aircraft Passenger Cabin, filed Dec. 1, 2006.
 U.S. Appl. No. 29/250,810. Title:Furniture for a Commercial Aircraft Passenger Cabin, filed Dec. 1, 2006.
 U.S. Appl. No. 29/250,829. Title:Furniture for a Commercial Aircraft Passenger Cabin, filed Dec. 1, 2006.
 U.S. Appl. No. 29/250,813. Title:Armrest/Backrest Combination for an Ottoman for a Commercial Aircraft Passenger Cabin, filed Dec. 1, 2006.

* cited by examiner

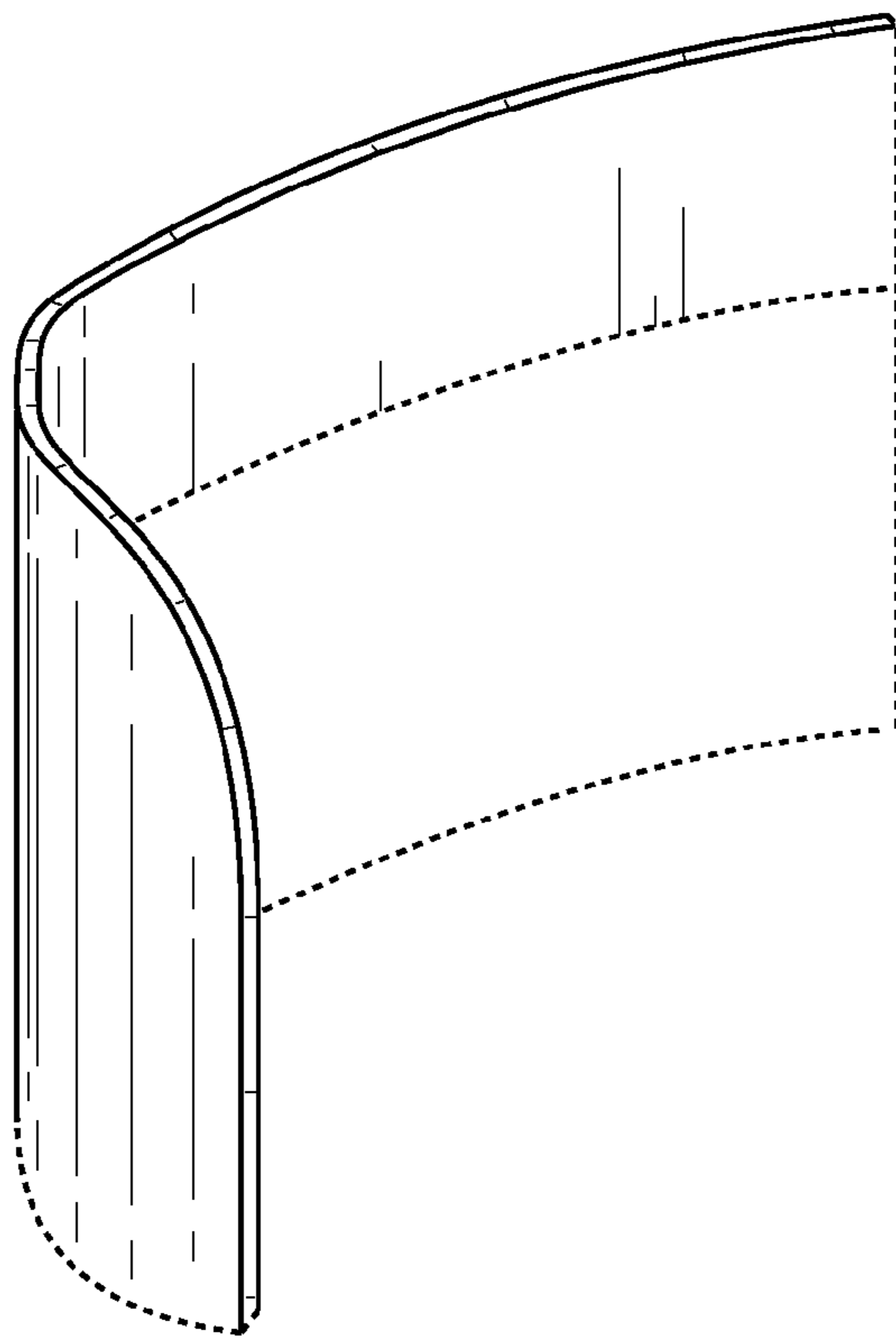

FIG. 1

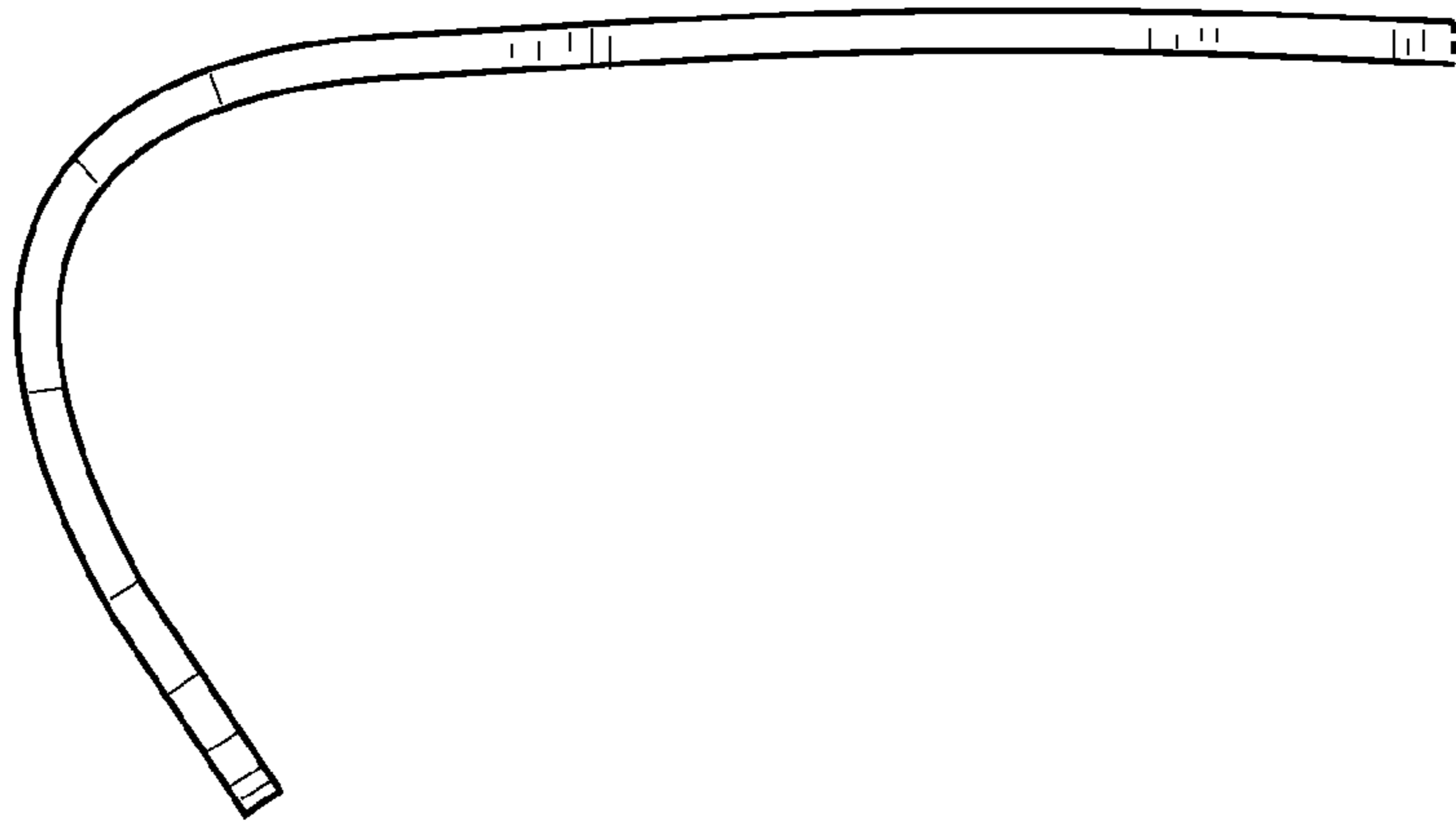

FIG. 2

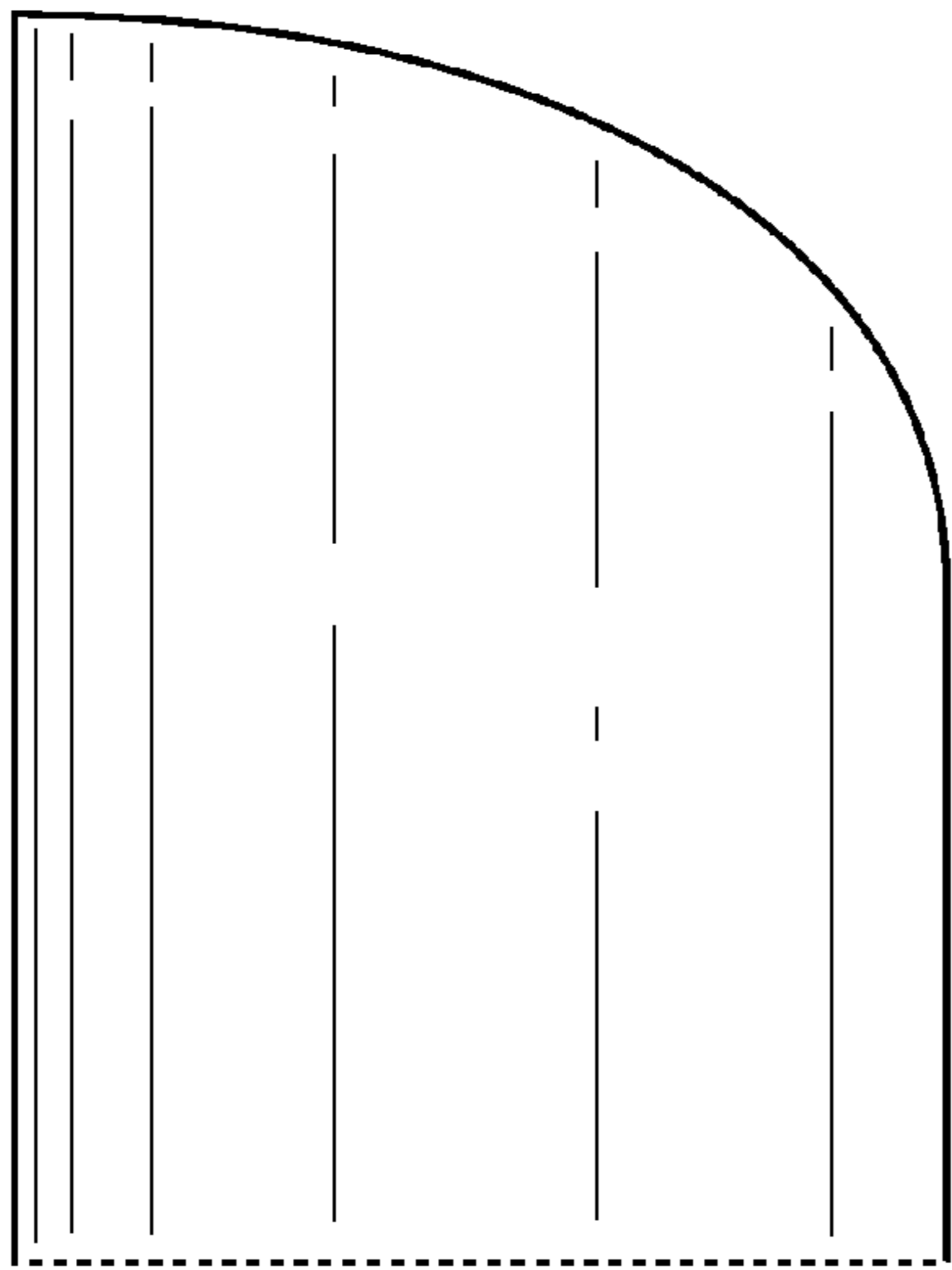

FIG. 3

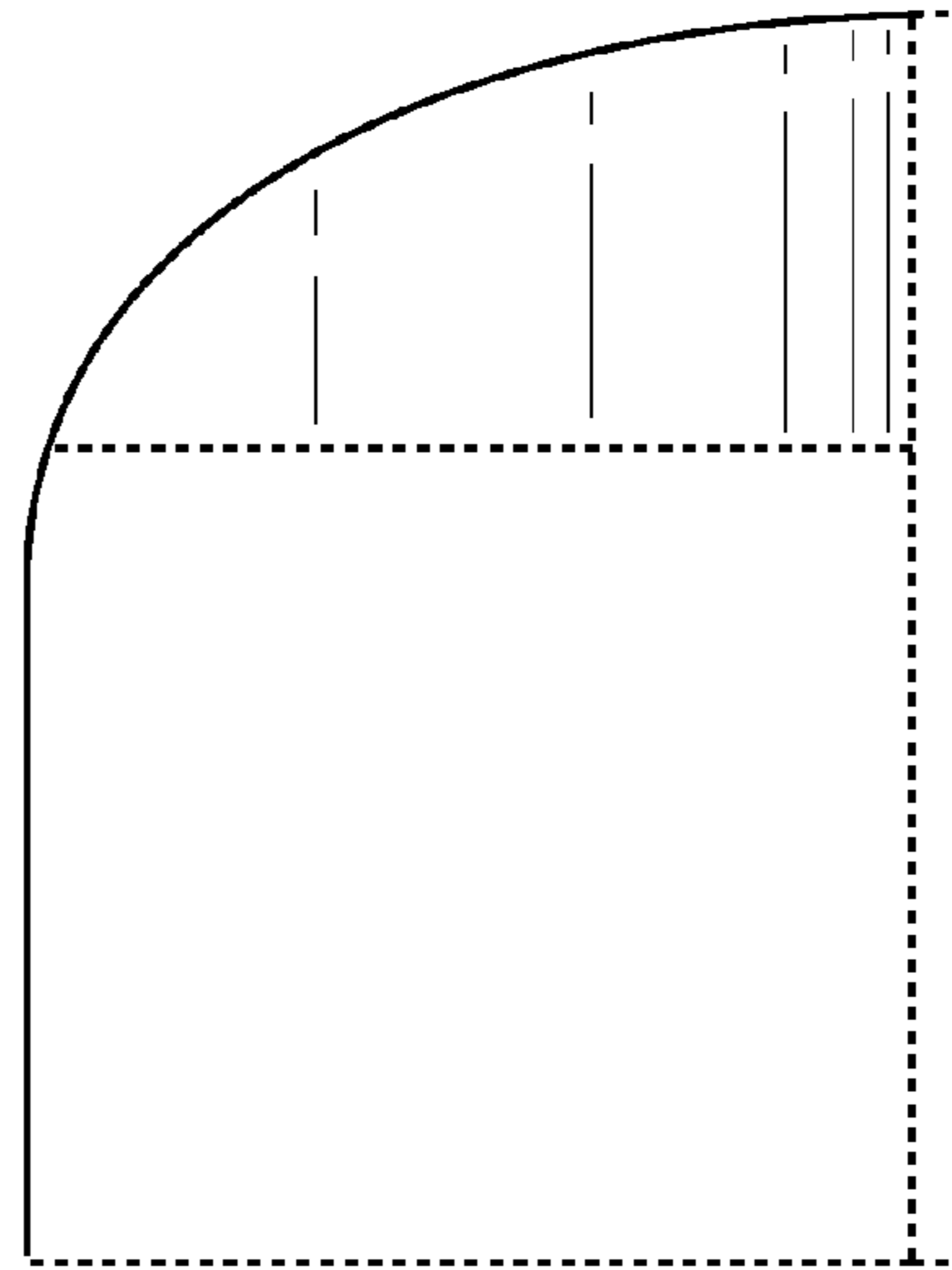

FIG. 4

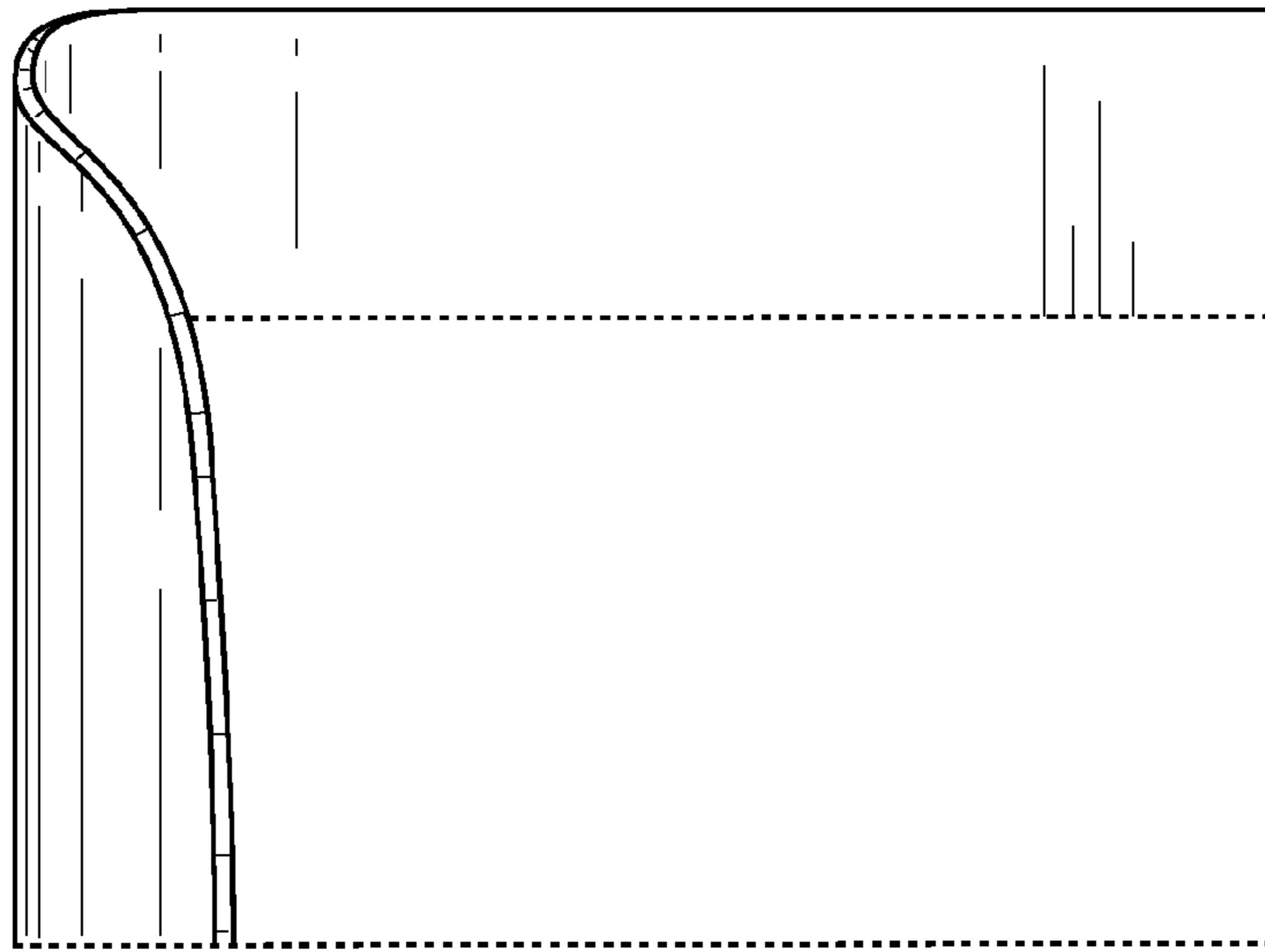

FIG. 5

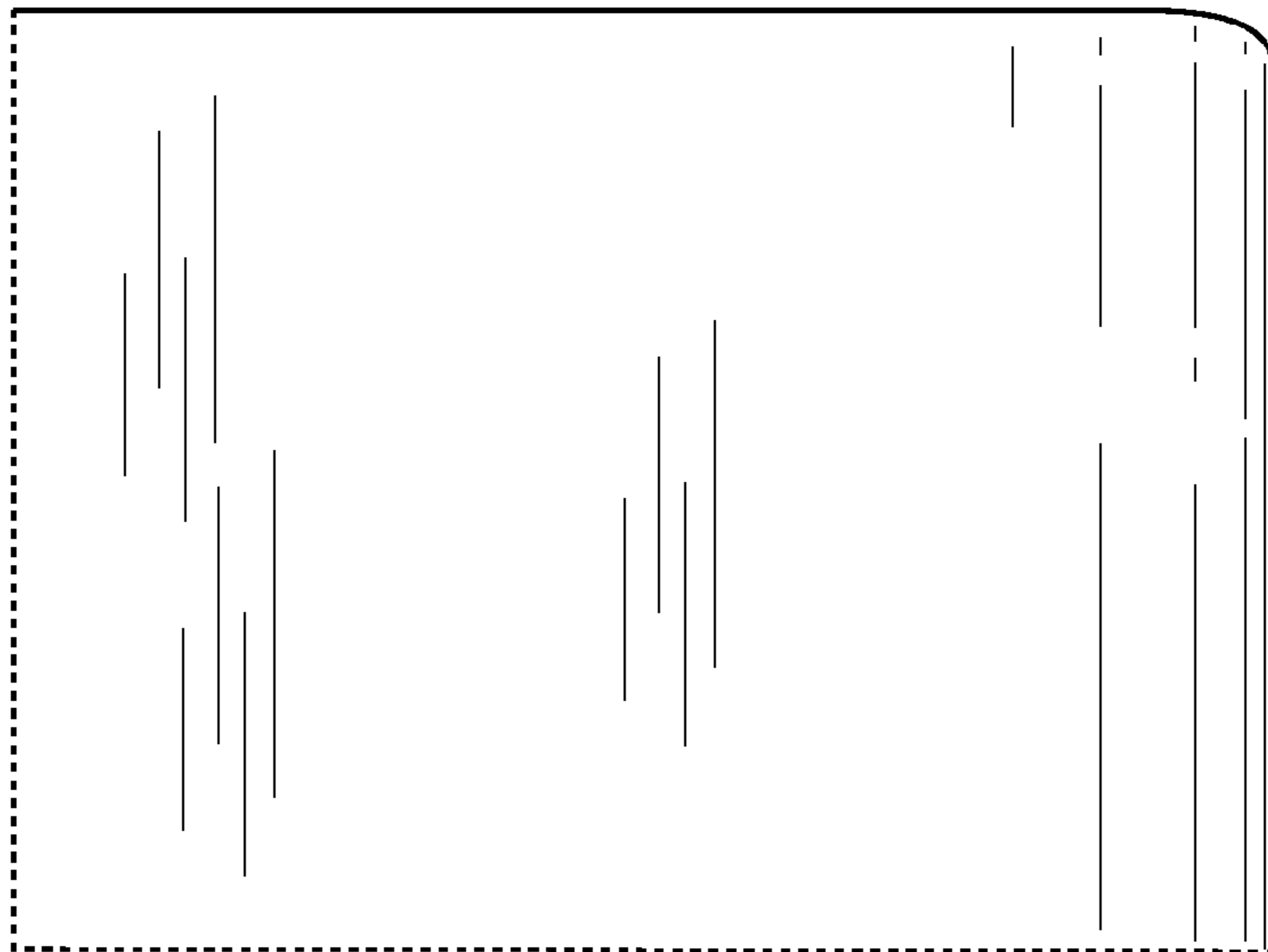

FIG. 6

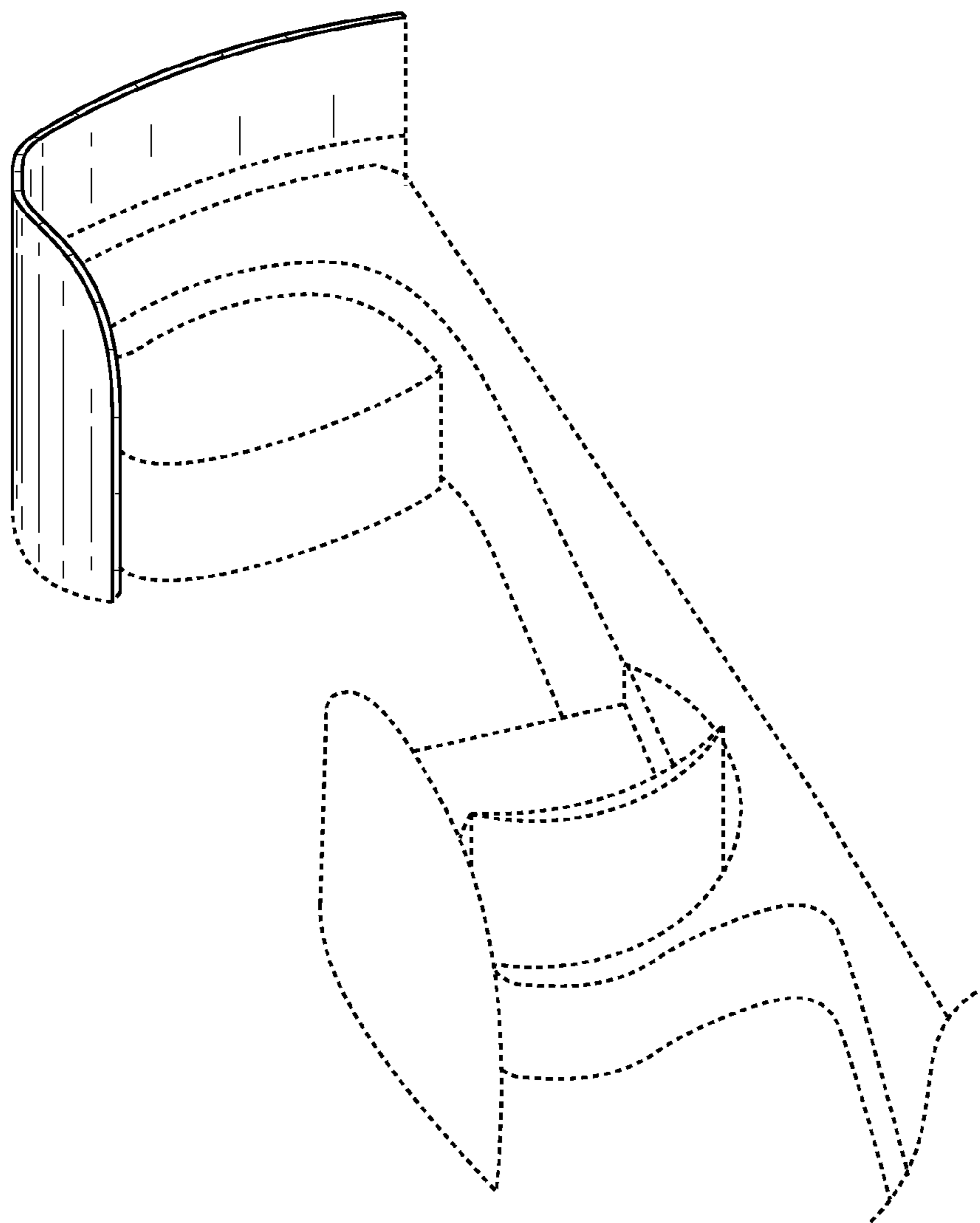

FIG. 7

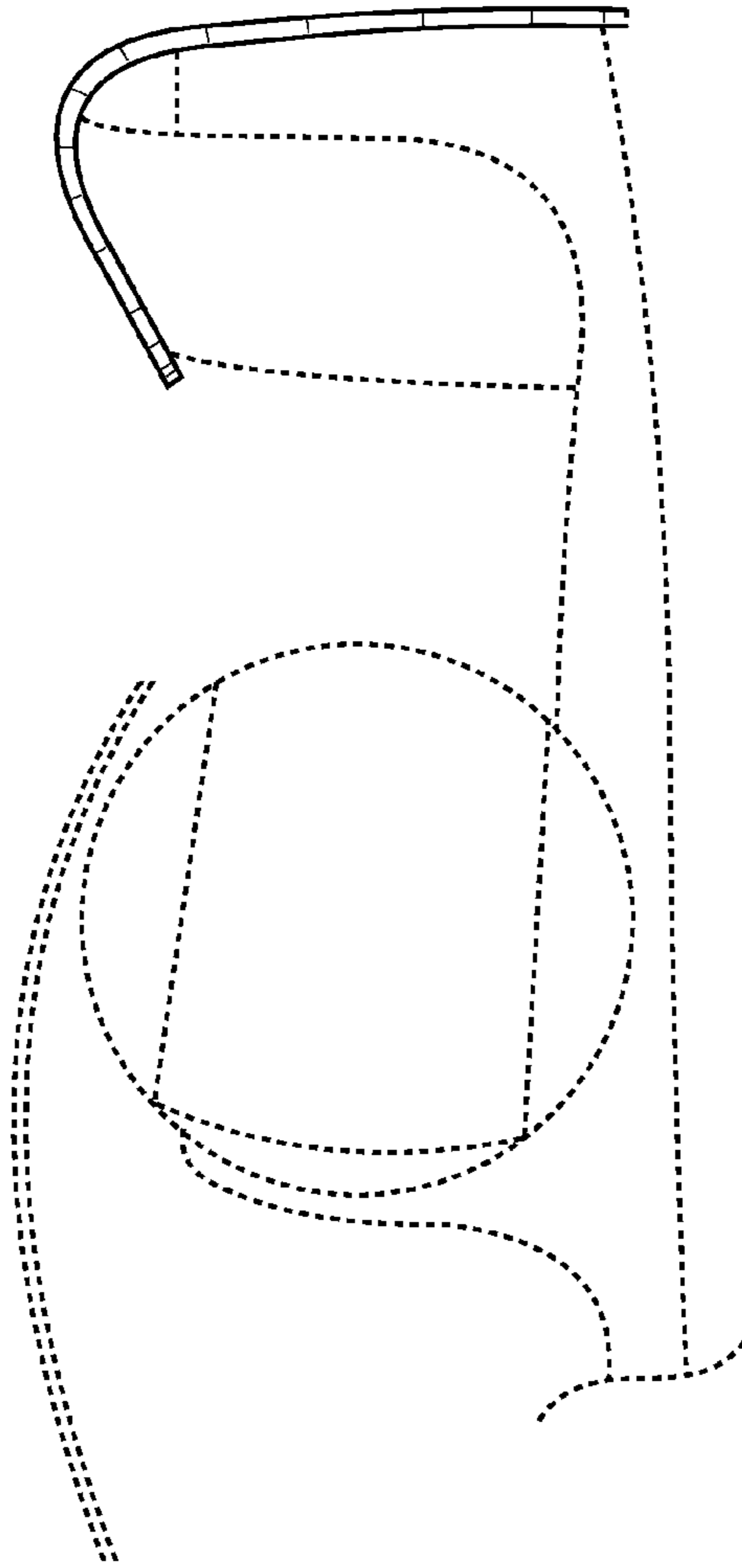

FIG. 8

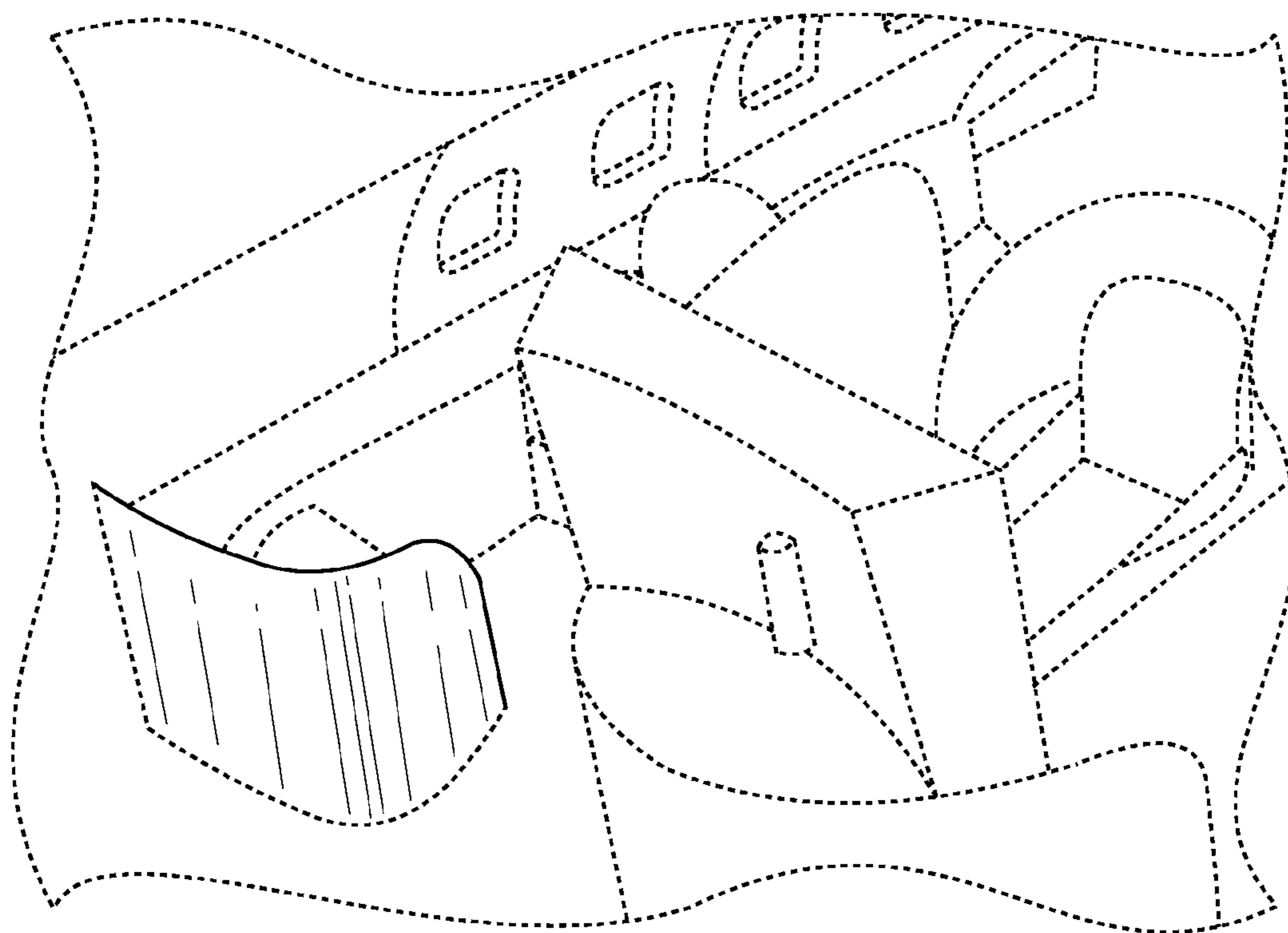

FIG. 9

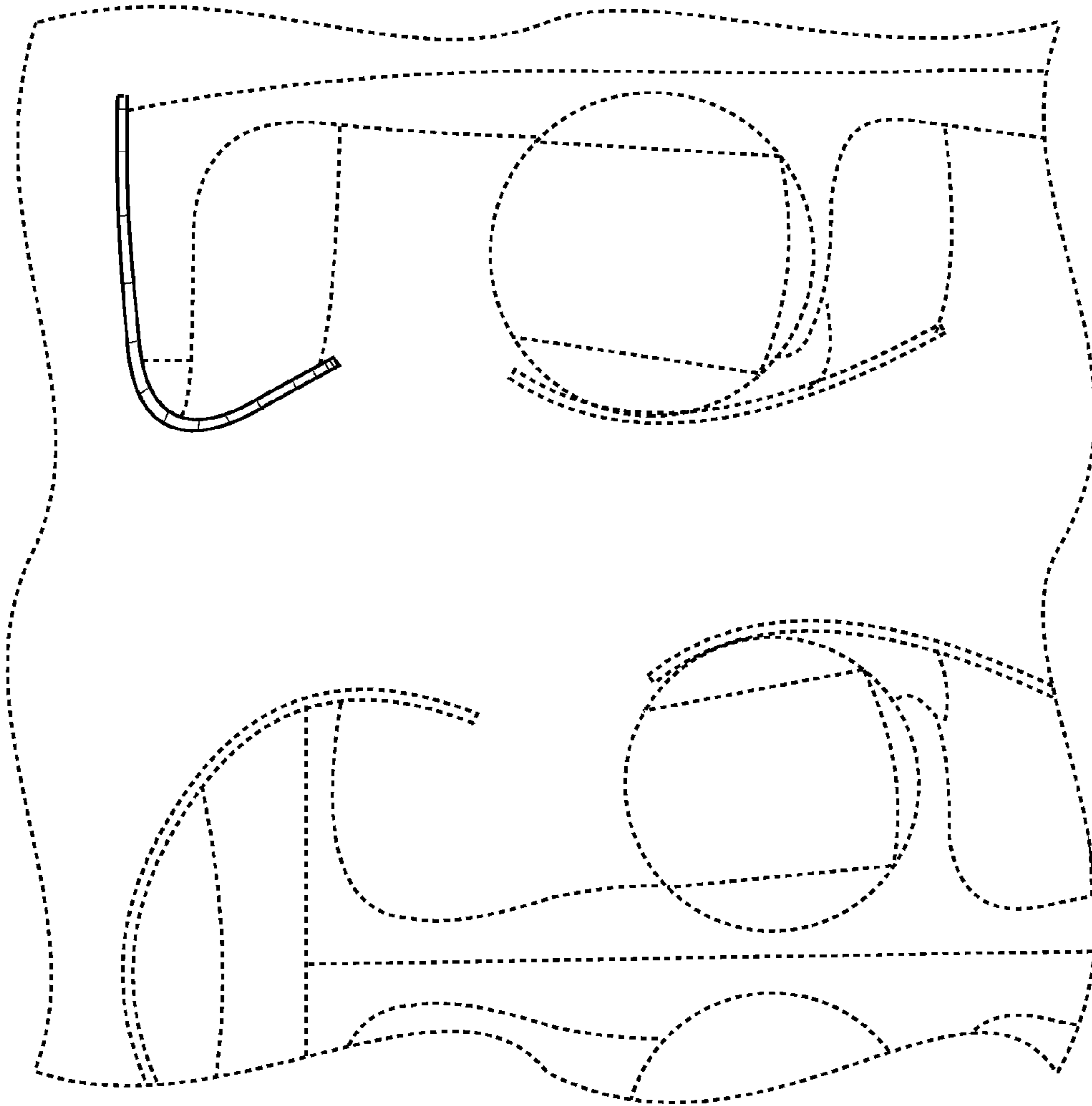

FIG. 10